

**TECHNICAL MANUAL**  
**AVIATION UNIT AND INTERMEDIATE**  
**MAINTENANCE MANUAL**  
**VOLUME 8 OF 9**  
**ARMY MODEL**  
**AH-64A HELICOPTER**  
**(NSN 1520-01-106-9519)**  
**(EIC: RHA)**

- CHAPTER 12 - UTILITY SYSTEMS**
- CHAPTER 13 - ENVIRONMENTAL CONTROL SYSTEM**
- CHAPTER 14 - HOISTS AND WINCHES (not applicable)**
- CHAPTER 15 - AUXILIARY POWER PLANTS**
- CHAPTER 16 - MISSION EQUIPMENT**
- CHAPTER 17 - EMERGENCY EQUIPMENT**  
**(not applicable)**

**DISTRIBUTION STATEMENT A:** Approved for public release; distribution is unlimited.

**DESTRUCTION NOTICE** For unclassified, limited documents, destroy by any method that will prevent disclosure of contents or reconstruction of the document

\* This manual together with TM 1-1520-238-23-1, 16 May 1994, TM 1-1520-238-23-2, 16 May 1994, TM 1-1520-238-23-3, 16 May 1994, TM 1-1520-238-23-4, 16 May 1994, TM 1-1520-238-23-5, 16 May 1994, TM 1-1520-238-23-6, 16 May 1994, TM 1-1520-238-23-7-1, 16 May 1994, TM 1-1520-238-23-7-2, 16 May 1994, TM 1-1520-238-23-9, 16 May 1994, supersedes TM 55-1520-238-23-1, 7 June 1988, TM 55-1520-238-23-2, 7 June 1988, TM 55-1520-238-23-3, 7 June 1988, TM 55-1520-238-23-4, 7 June 1988, TM 55-1520-238-23-5, 7 June 1988, TM 55-1520-238-23-6, 7 June 1988, TM 55-1520-238-23-7, 7 June 1988, TM 55-1520-238-23-8, 7 June 1988, TM 55-1520-238-23-9, 7 June 1988, TM 55-1520-238-23-10, 7 June 1988, including all changes.

<b>WINDSHIELD WIPER SYSTEM MAINTENANCE</b>
<b>FIRE DETECTION SYSTEM MAINTENANCE</b>
<b>FIRE EXTINGUISHING SYSTEM MAINTENANCE</b>
<b>ANTI-ICE/DE-ICE SYSTEM MAINTENANCE</b>
<b>CANOPY JETTISON SYSTEM MAINTENANCE</b>
<b>ENVIRONMENTAL CONTROL SYSTEM MAINTENANCE</b>
<b>DEFOG SYSTEM MAINTENANCE</b>
<b>AUXILIARY POWER SYSTEM MAINTENANCE</b>
<b>AUXILIARY POWER UNIT MOUNTING AND DRAIN SYSTEM</b>
<b>AUXILIARY POWER UNIT EXHAUST SYSTEM</b>
<b>EXTERNAL STORES/PYLONS MAINTENANCE</b>
<b>COUNTERMEASURE SYSTEM MAINTENANCE</b>
<b>WINTERIZATION/BATTERY COLD START SYSTEM MAINTENANCE</b>
<b>DESERT OPERATION PROVISIONS MAINTENANCE</b>



CHANGE }  
NO. 9 }

HEADQUARTERS  
DEPARTMENT OF THE ARMY  
WASHINGTON, D.C., 30 SEPTEMBER 2004

## Aviation Unit and Intermediate Maintenance Manual

**HELICOPTER, ATTACK,  
AH-64A APACHE  
(NSN 1520-01-106-9519)  
(EIC:RHA)**

DISTRIBUTION STATEMENT A: Approved for public release; distribution is unlimited.

TM 1-1520-238-23-8, 16 May 1994, is changed as follows:

1. Remove and insert pages as indicated below. New or changed text material is indicated by a vertical bar in the margin. An illustration change is indicated by a miniature pointing hand.

Remove pages

Insert pages

A and B

A and B

16-15 through 16-24

16-15 through 16-24

2. Retain this sheet in front of manual for reference purposes.

By Order of the Secretary of the Army:

Official: \_\_\_\_\_

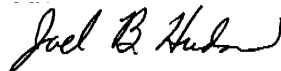

**JOEL B. HUDSON**

*Administrative Assistant to the  
Secretary of the Army*

0423003

**PETER J. SCHOOMAKER**  
*General, United States Army  
Chief of Staff*

**DISTRIBUTION:**

To be distributed in accordance with Initial Distribution No. (IDN) 313448, requirements for TM 1-1520-238-23-8.



CHANGE }  
NO. 8 }

HEADQUARTERS  
DEPARTMENT OF THE ARMY  
WASHINGTON, D.C., 15 SEPTEMBER 2003

## Aviation Unit and Intermediate Maintenance Manual

**HELICOPTER, ATTACK,  
AH-64A APACHE  
(NSN 1520-01-106-9519)  
(EIC:RHA)**

DISTRIBUTION STATEMENT A: Approved for public release; distribution is unlimited.

### OZONE DEPLETING CHEMICAL INFORMATION

This document has been reviewed for the presence of Class I Ozone Depleting Chemicals. As of base through change 05, dated 10 May 2000, all references to Class I Ozone Depleting Chemicals have been removed from this document by substitution with chemicals that do not cause atmospheric Ozone depletion.

TM 1-1520-238-23-8, 16 May 1994, is changed as follows:

1. Remove and insert pages as indicated below. New or changed text material is indicated by a vertical bar in the margin. An illustration change is indicated by a miniature pointing hand.

#### Remove pages

A and B  
C/(D blank)  
12-131 and 132  
12-136.1 and 12-136.2  
12-317 and 12-318  
15-5 and 15-6  
15-13 through 15-16  
15-151 and 15-152  
16-1 through 16-114  
- - - -  
16-133 and 16-134

#### Insert pages

A and B  
- - - -  
12-131 and 12-132  
12-136.1 and 12-136.2  
12-317 and 12-318  
15-5 and 15-6  
15-13 through 15-16  
15-151 and 15-152  
16-1 through 16-114  
16-114.1 through 16-114.4  
16-133 and 16-134

2. Retain this sheet in front of manual for reference purposes.

By Order of the Secretary of the Army:

Official:



JOEL B. HUDSON  
*Administrative Assistant to the  
Secretary of the Army*  
0322009

PETER J. SCHOOMAKER  
*General, United States Army  
Chief of Staff*

**DISTRIBUTION:**

To be distributed in accordance with Initial Distribution No. (IDN) 313448, requirements for TM 1-1520-238-23-8.

CHANGE }  
NO. 7 }

HEADQUARTERS  
DEPARTMENT OF THE ARMY  
WASHINGTON, D.C., 15 May 2002

## Aviation Unit and Intermediate Maintenance Manual

**HELICOPTER, ATTACK,  
AH-64A APACHE  
(NSN 1520-01-106-9519)  
(EIC:RHA)**

DISTRIBUTION STATEMENT A: Approved for public release; distribution is unlimited.

TM 1-1520-238-23-8, 16 May 1994, is changed as follows:

1. Remove and insert pages as indicated below. New or changed text material is indicated by a vertical bar in the margin. An illustration change is indicated by a miniature pointing hand.

### Remove pages

A and B  
- - - - -  
12-101 and 12-102  
- - - - -  
12-103 and 12-104  
12-119 through 12-120  
- - - - -  
12-123 and 12-124  
12-125 through 12-128  
12-135 and 12-136  
- - - - -  
12-137 and 12-138  
(15-119 blank)/15-120  
15-121 and 15-122  
16-47 through 16-50

### Insert pages

A and B  
C/(D blank)  
12-101 and 12-102  
12-102.1 and 12-102.2  
12-103 and 12-104  
12-119 through 12-120  
12-122.1 and 12-122.2  
(12-123 blank)/12-124  
12-125 through 12-128  
12-135 and 12-136  
12-136.1 and 12-136.2  
(12-137 blank)/12-138  
(15-119 blank)/15-120  
15-121 and 15-122  
16-47 through 16-50

2. Retain this sheet in front of manual for reference purposes.

By Order of the Secretary of the Army:

Official:



JOEL B. HUDSON

*Administrative Assistant to the  
Secretary of the Army*

0208105

ERIC K. SHINSEKI  
*General, United States Army  
Chief of Staff*

**DISTRIBUTION:**

To be distributed in accordance with Initial Distribution No. (IDN) 313448, requirements for TM 1-1520-238-23-8.



CHANGE }  
NO. 6 }

HEADQUARTERS  
DEPARTMENT OF THE ARMY  
WASHINGTON, D.C., 31 July 2001

Aviation Unit and Intermediate Maintenance Manual

**HELICOPTER, ATTACK,  
AH-64A APACHE  
(NSN 1520-01-106-9519)  
(EIC:RHA)**

DISTRIBUTION STATEMENT A: Approved for public release; distribution is unlimited.

TM 1-1520-238-23-8, 16 May 1994, is changed as follows:

1. Remove and insert pages as indicated below. New or changed text material is indicated by a vertical bar in the margin. An illustration change is indicated by a miniature pointing hand.

Remove pages

-----  
16-1 through 16-6  
16-17 and 16-18  
16-21 and 16-22  
16-33 and 16-34  
16-59 and 16-60  
16-97 and 16-98  
-----

Insert pages

A and B  
16-1 through 16-6  
16-17 and 16-18  
16-21 and 16-22  
16-33 and 16-34  
16-59 and 16-60  
16-97 and 16-98  
16-122.5 through 16-122.13/(16-122.14  
blank)

2. Retain this sheet in front of manual for reference purposes.

By Order of the Secretary of the Army:

Official:



JOEL B. HUDSON

*Administrative Assistant to the  
Secretary of the Army*

0119405

ERIC K. SHINSEKI  
*General, United States Army  
Chief of Staff*

**DISTRIBUTION:**

To be distributed in accordance with initial distribution No. (IDN 3448) requirements for  
TM 1-1520-238-23-8.



CHANGE }  
NO. 5 }

HEADQUARTERS  
DEPARTMENT OF THE ARMY  
WASHINGTON, D.C., 10 MAY 2000

## Aviation Unit and Intermediate Maintenance Manual

**HELICOPTER, ATTACK,  
AH-64A APACHE  
(NSN 1520-01-106-9519)  
(EIC:RHA)**

DISTRIBUTION STATEMENT A: Approved for public release; distribution is unlimited.

TM 1-1520-238-23-8, 16 May 1994, is changed as follows:

1. Remove and insert pages as indicated below. New or changed text material is indicated by a vertical bar in the margin. An illustration change is indicated by a miniature pointing hand.

### Remove pages

-----  
13-1 and 13-2  
13-47 and 13-48  
13-49 through 13-52  
15-5 and 15-6  
15-11 through 15-14  
15-121 through 15-128  
15-131 and 15-132  
15-147 through 15-150

### Insert pages

A through C/(D blank)  
13-1 and 13-2  
13-47 and 13-48  
(13-51 blank)13-52  
15-5 and 15-6  
15-11 through 15-14  
15-121 through 15-128  
15-131 and 15-132  
15-147 through 15-150

2. Retain this sheet in front of manual for reference purposes.

By Order of the Secretary of the Army:

Official:



JOEL B. HUDSON  
*Administrative Assistant to the  
Secretary of the Army*  
0013202

ERIC K. SHINSEKI  
*General, United States Army  
Chief of Staff*

**DISTRIBUTION:**

To be distributed in accordance with initial distribution No. (IDN 313448) requirements for TM 1-1520-238-23-8.

CHANGE }  
NO. 4 }

HEADQUARTERS  
DEPARTMENT OF THE ARMY  
WASHINGTON, D.C., 19 December 1997

## Aviation Unit and Intermediate Maintenance Manual

### HELICOPTER, ATTACK, AH-64A APACHE (NSN 1520-01-106-9519) (EIC:RHA)

DISTRIBUTION STATEMENT A: Approved for public release; distribution is unlimited.

TM 1-1520-238-23-8, 16 May 1994, is changed as follows:

1. Remove and insert pages as indicated below. New or changed text material is indicated by a vertical bar in the margin. An illustration change is indicated by a miniature pointing hand.

Remove pages	Insert pages
12-317 and 12-318 12-325 and 12-326	12-317 and 12-318 12-325 and 12-326
13-27 and 13-28 13-85 and 13-86 13-91 and 13-92	13-27 and 13-28 13-85 and 13-86 13-91 and 13-92
15-1 and 15-2 15-5 and 15-6 15-19 and 15-20 15-21 through 15-54 - - - -	15-1 and 15-2 15-5 and 15-6 15-19 and 15-20 - - - - (15-53 blank)/15-54
15-55 and 15-56 15-57 through 15-82 - - - -	15-55 and 15-56 - - - - (15-81 blank)/15-82
15-83 and 15-84 15-85 through 15-90 - - - -	15-83 and 15-84 - - - - (15-89 blank)/15-90
15-93 and 15-94 15-95 through 15-120 - - - -	15-93 and 15-94 - - - - (15-119 blank)/15-120
15-158.1 and 15-158.2 15-169/(15-170 blank)	15-158.1 and 15-158.2 15-169/(15-170 blank)
16-1 and 16-2 16-9 through 16-12 16-17 through 16-20 16-97 and 16-98 - - - -	16-1 and 16-2 16-9 through 16-12 16-17 through 16-20 16-97 and 16-98 16-122.1 through 16-122.4

2. Retain this sheet in front of manual for reference purposes.

By Order of the Secretary of the Army:

Official:



JOEL B. HUDSON

*Administrative Assistant to the  
Secretary of the Army*

04555

DENNIS J. REIMER  
*General, United States Army  
Chief of Staff*

**DISTRIBUTION:**

To be distributed in accordance with Initial Distribution No. (IDN) 313448, requirements for TM 1-1520-238-23-8.

CHANGE }  
NO. 3 }

HEADQUARTERS  
DEPARTMENT OF THE ARMY  
WASHINGTON, D.C., 30 SEPTEMBER 1996

## Aviation Unit and Intermediate Maintenance Manual

### HELICOPTER, ATTACK, AH-64A APACHE (NSN 1520-01-106-9519) (EIC:RHA)

DISTRIBUTION STATEMENT A: Approved for public release; distribution is unlimited.

TM 1-1520-238-23-8, 16 May 1994, is changed as follows:

1. Remove and insert pages as indicated below. New or changed text material is indicated by a vertical bar in the margin. An illustration change is indicated by a miniature pointing hand.

Remove pages	Insert pages
12-101 through 12-104	12-101 through 12-104
12-127 through 12-132	12-127 through 12-132
-----	12-132.1/(132.2 blank)
12-135 through 12-138	12-135 through 12-138
12-155 and 12-156	12-155 and 12-156
12-169 through 12-174	12-169 through 12-174
13-35 through 13-40	13-35 through 13-40
15-3 and 15-4	15-3 and 15-4
15-35 and 15-36	15-35 and 15-36
15-55 through 15-68	15-55 through 15-68
15-71 and 15-72	15-71 and 15-72
15-103 and 15-104	15-103 and 15-104
15-147 and 15-148	15-147 and 15-148
15-151 through 15-158	15-151 through 15-158
15-158.1 and 15-158.2	15-158.1 and 15-158.2
15-159 through 15-164	15-159 through 15-164
15-167 through 15-169/(15-170 blank)	15-167 through 15-169/(15-170 blank)
16-3 and 16-6	16-3 and 16-6
16-13 and 16-18	16-13 and 16-18
16-21 and 16-22	16-21 and 16-22
16-25 and 16-26	16-25 and 16-26
16-35 through 16-38	16-35 through 16-38
16-77 and 16-78	16-77 and 16-78
16-85 and 16-86	16-85 and 16-86
16-115 and 16-116	16-115 and 16-116
16-135 and 16-136	16-135 and 16-136
-----	E-mail instruction page

2. Retain this sheet in front of manual for reference purposes.

By Order of the Secretary of the Army:

Official:



JOEL B. HUDSON

*Administrative Assistant to the  
Secretary of the Army*

02703

DENNIS J. REIMER  
*General, United States Army  
Chief of Staff*

**DISTRIBUTION:**

To be distributed in accordance with DA Form 12-31-E, block no. 3448, requirements for TM 1-1520-238-23-8.



CHANGE }  
NO. 2 }

HEADQUARTERS  
DEPARTMENT OF THE ARMY  
WASHINGTON, D.C., 16 FEBRUARY 1996

## Aviation Unit and Intermediate Maintenance Manual

### HELICOPTER, ATTACK, AH-64A APACHE (NSN 1520-01-106-9519) (EIC:RHA)

DISTRIBUTION STATEMENT A: Approved for public release; distribution is unlimited.

TM 1-1520-238-23-8, 16 May 1994, is changed as follows:

1. Remove and insert pages as indicated below. New or changed text material is indicated by a vertical bar in the margin. An illustration change is indicated by a miniature pointing hand.

#### Remove pages

12-1 19 and 12-120  
12-175 and 12-176  
12-179 and 12-180  
15-7 and 15-8  
15-17 and 15-18  
15-57 and 15-58  
15-61 through 15-66  
15-145 through 15-148  
16-19 through 16-22  
16-33 and 16-34  
16-87 and 16-88  
16-1 15 through 16-118

#### Insert pages

12-1 19 and 12-120  
12-175 and 12-176  
12-179 and 12-180  
15-7 and 15-8  
15-17 and 15-18  
15-57 and 15-58  
15-61 through 15-66  
15-145 through 15-148  
16-19 through 16-22  
16-33 and 16-34  
16-87 and 16-88  
16-1 15 through 16-118

2. Retain this sheet in front of manual for reference purposes.

By Order of the Secretary of the Army:

Official:



JOEL B. HUDSON

*Acting Administrative Assistant to the  
Secretary of the Army*

01683

DENNIS J. REIMER  
*General, United States Army  
Chief of Staff*

**DISTRIBUTION:**

To be distributed in accordance with DA Form 12-31-E, block no. 3448, requirements for TM 1-1520-238-23-8.

CHANGE }  
NO. 1 }

HEADQUARTERS  
DEPARTMENT OF THE ARMY  
WASHINGTON, D.C., 17 MAY 1995

## Aviation Unit and Intermediate Maintenance Manual

### HELICOPTER, ATTACK, AH-64A APACHE (NSN 1520-01-106-9519) (EIC: RHA)

DISTRIBUTION STATEMENT A: Approved for public release; distribution is unlimited.

TM 1-1520-238-23-8, 16 May 1994, is changed as follows:

1. Remove and insert pages as indicated below. New or changed text material is indicated by a vertical bar in the margin. An illustration change is indicated by a miniature pointing hand.

#### Remove pages

12-3 and 12-4  
12-101 through 12-104  
12-155 through 12-158  
12-261 through 12-268  
12-317 and 12-318  
13-5 and 13-6  
13-17 through 13-24  
13-29 through 13-36  
13-45 through 13-48  
13-53 and 13-54  
13-137 through 13-140  
-----  
15-5 through 15-8  
15-13 through 15-16  
15-57 through 15-62  
15-77 and 15-78  
15-93 and 15-94  
15-121 through 15-124  
15-137 through 15-144  
15-151 through 15-158  
-----  
16-1 and 16-2  
16-9 and 16-10  
16-37 through 16-42  
16-61 through 16-66  
16-77 through 16-86  
16-129 through 16-132

#### Insert pages

12-3 and 12-4  
12-101 through 12-104  
12-155 through 12-158  
12-261 through 12-268  
12-317 and 12-318  
13-5 and 13-6  
13-17 through 13-24  
13-29 through 13-36  
13-45 through 13-48  
13-53 and 13-54  
13-137 through 13-140  
13-140.1/(13-140.2 blank)  
15-5 through 15-8  
15-13 through 15-16  
15-57 through 15-62  
15-77 and 15-78  
15-93 and 15-94  
15-121 through 15-124  
15-137 through 15-144  
15-151 through 15-158  
15-158.1 and 15-158.2  
16-1 and 16-2  
16-9 and 16-10  
16-37 through 16-42  
16-61 through 16-66  
16-77 through 16-86  
16-129 through 16-132

2. Retain this sheet in front of manual for reference purposes.

By Order of the Secretary of the Army:

Official:

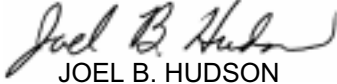

JOEL B. HUDSON

*Acting Administrative Assistant to the  
Secretary of the Army*

00168

GORDON R. SULLIVAN  
*General, United States Army  
Chief of Staff*

**DISTRIBUTION:**

To be distributed in accordance with DA Form 12-31-E, block no. 3448, requirements for TM 1-1520-238-23-8.

INSERT LATEST CHANGED PAGES: DESTROY SUPERSEDED PAGES.

**LIST OF EFFECTIVE PAGES**

**NOTE:** The portion of the text affected by the changes is indicated by a vertical line in the outer margins of the page. Changes to illustrations are indicated by miniature pointing hands. Changes to wiring diagrams are indicated by shaded areas.

Date of issue for original and change pages are:

Original . . . . . 0 . . . . . 16 May 1994	Change . . . . . 5 . . . . . 10 May 2000
Change . . . . . 1 . . . . . 17 May 1995	Change . . . . . 6 . . . . . 31 July 2001
Change . . . . . 2 . . . . . 16 February 1996	Change . . . . . 7 . . . . . 15 May 2002
Change . . . . . 3 . . . . . 30 September 1996	Change . . . . . 8 . . . . . 15 September 2003
Change . . . . . 4 . . . . . 19 December 1997	Change . . . . . 9 . . . . . TBD

**TOTAL NUMBER OF PAGES IN THIS PUBLICATION IS 740, CONSISTING OF THE FOLLOWING:**

<b>Page No.</b>	<b>*Change No.</b>	<b>Page No.</b>	<b>*Change No.</b>
Cover . . . . .	0	12-262 - 12-268 . . . . .	1
Blank . . . . .	0	12-269 - 12-316 . . . . .	0
A - B . . . . .	9	12-317 . . . . .	1
C Deleted . . . . .	8	12-318 . . . . .	8
D Blank Deleted . . . . .	8	12-319 - 12-324 . . . . .	0
12-1 - 12-2 . . . . .	0	12-325 . . . . .	4
12-3 . . . . .	1	12-326 - 12-329 . . . . .	0
12-4 - 12-101 . . . . .	0	12-330 Blank . . . . .	0
12-102 . . . . .	7	13-1 . . . . .	0
12-102.1 - 12-102.2 Added . . . . .	7	13-2 . . . . .	5
12-103 . . . . .	7	13-3 - 13-4 . . . . .	0
12-104 - 12-119 . . . . .	0	13-5 . . . . .	1
12-120 . . . . .	7	13-6 - 13-16 . . . . .	0
12-121 - 12-122 . . . . .	0	13-17 . . . . .	1
12-122.1 - 12-122.2 Added . . . . .	7	13-18 - 13-19 . . . . .	0
12-123 Blank . . . . .	7	13-20 - 13-24 . . . . .	1
12-124 - 12-127 . . . . .	7	13-25 - 13-27 . . . . .	0
12-128 . . . . .	3	13-28 . . . . .	4
12-129 . . . . .	0	13-29 . . . . .	0
12-130 - 12-131 . . . . .	3	13-30 . . . . .	1
12-132 . . . . .	8	13-31 . . . . .	0
12-132.1 Added . . . . .	3	13-32 - 13-33 . . . . .	1
12-132.2 Blank Added . . . . .	3	13-34 . . . . .	0
12-133 - 12-134 . . . . .	0	13-35 - 13-37 . . . . .	3
12-135 . . . . .	7	13-38 . . . . .	0
12-136 . . . . .	0	13-39 . . . . .	3
12-136.1 . . . . .	8	13-40 - 13-45 . . . . .	0
12-136.2 Added . . . . .	7	13-46 - 13-47 . . . . .	1
12-137 Blank . . . . .	7	13-48 . . . . .	5
12-138 . . . . .	7	13-49 - 13-50 Deleted . . . . .	5
12-139 - 12-154 . . . . .	0	13-51 Blank . . . . .	5
12-155 . . . . .	3	13-52 . . . . .	5
12-156 - 12-158 . . . . .	1	13-53 . . . . .	1
12-159 - 12-169 . . . . .	0	13-54 - 13-85 . . . . .	0
12-170 . . . . .	3	13-86 . . . . .	4
12-171 . . . . .	0	13-87 - 13-90 . . . . .	0
12-172 - 12-173 . . . . .	3	13-91 - 13-92 . . . . .	4
12-174 . . . . .	0	13-93 - 13-136 . . . . .	0
12-175 . . . . .	2	13-137 . . . . .	1
12-176 - 12-179 . . . . .	0	13-138 . . . . .	0
12-180 . . . . .	2	13-139 - 13-140 . . . . .	1
12-181 - 12-261 . . . . .	0		

\*Zero in this column indicates an original page.

INSERT LATEST CHANGED PAGES: DESTROY SUPERSEDED PAGES.

**LIST OF EFFECTIVE PAGES**

Page No.	*Change No.	Page No.	*Change No.
13-140.1 Added	1	15-126	0
13-140.2 Blank Added	1	15-127 - 15-128	5
13-141 - 13-146	0	15-129 - 15-130	0
14-1	0	15-131 - 15-132	5
14-2 Blank	0	15-133 - 15-137	0
15-1 - 15-2	4	15-138 - 15-144	1
15-3	0	15-145	0
15-4	3	15-146	2
15-5	8	15-147	3
15-6	5	15-148 - 15-150	5
15-7 - 15-8	2	15-151	8
15-9 - 15-11	0	15-152 - 15-158	3
15-12	5	15-158.1	4
15-13	8	15-158.2 Added	3
15-14 - 15-15	0	15-159 - 15-160	3
15-16	8	15-161	0
15-17	6	15-162 - 15-163	3
15-18 - 15-19	0	15-164 - 15-166	0
15-20	4	15-167 - 15-168	3
15-21 - 15-52 Deleted	4	15-169	4
15-53 Blank	4	15-170 Blank	4
15-54	4	16-1	1
15-55	3	16-2 - 16-15	8
15-56	4	16-16	9
15-57 - 15-80 Deleted	4	16-17	8
15-81 Blank	4	16-18 - 16-24	9
15-82	4	16-25 - 16-114	8
15-83	0	16-114.1 - 16-114.4 Added	8
15-84	4	16-115 - 16-122	0
15-85 - 15-88 Deleted	4	16-122.1 - 16-122.4 Added	4
15-89 Blank	4	16-122.5 - 16-122.13 Added	6
15-90	4	16-122.14 Blank Added	6
15-91 - 15-92	0	16-123 - 16-128	0
15-93	1	16-129 - 16-131	1
15-94	4	16-132	0
15-95 - 15-118 Deleted	4	16-133 - 16-134	8
15-119 Blank	4	16-135	3
15-120	7	16-136 - 16-137	0
15-121	1	16-138 Blank	0
15-122	7	17-1	0
15-123	1	17-2 Blank	0
15-124 - 15-125	5		

\*Zero in this column indicates an original page.

## CHAPTER 12 UTILITY SYSTEM

### CHAPTER OVERVIEW

Chapter 12 contains the maintenance instructions for the utility systems. Utility systems description, operation, and troubleshooting information is contained in TM 1-1520-238-T.

### CHAPTER INDEX

<u>Para Title</u>	<u>Para No.</u>
<b>SECTION I. WINDSHIELD WIPER SYSTEM MAINTENANCE</b>	
Windshield Wiper System Inspection .....	12.1
Pilot Windshield Wiper Blade Replacement .....	12.2
Pilot Windshield Wiper Arm Replacement .....	12.3
Pilot Windshield Wiper Link Replacement .....	12.4
Pilot Windshield Wiper Converter Replacement .....	12.5
Pilot Windshield Wiper Flex Shaft Replacement .....	12.6
Pilot Windshield Wiper Motor Replacement .....	12.7
Pilot Windshield Wiper Alinement .....	12.8
CPG Windshield Wiper Blade Replacement .....	12.9
CPG Windshield Wiper Arm Replacement .....	12.10
CPG Windshield Wiper Link Replacement .....	12.11
CPG Windshield Wiper Converter Replacement .....	12.12
CPG Windshield Wiper Flex Shaft Replacement .....	12.13
CPG Windshield Wiper Motor Replacement .....	12.14
CPG Windshield Wiper Alinement .....	12.15

CHAPTER INDEX - continued

<u>Para Title</u>	<u>Para No.</u>
<b>SECTION II. FIRE DETECTION SYSTEM MAINTENANCE</b>	
Fire Detection System Inspection .....	12.16
APU Fire Panel Assembly Removal/Installation .....	12.17
APU Fire Panel Light Indicating Panel Removal/Installation .....	12.18
APU Fire Panel Switch Replacement (AVIM) .....	12.19
APU Fire Panel Indicator Replacement (AVIM) .....	12.20
APU Fire Panel Light Indicating Panel Receptacle Replacement (AVIM) .....	12.21
APU Fire Panel Circuit Card Replacement (AVIM) .....	12.22
Engine Flame Detector Replacement .....	12.23
APU Forward Flame Detector Replacement .....	12.24
APU Aft Flame Detector Replacement .....	12.25
Engine Flame Detector Control Amplifier Replacement .....	12.26
APU Flame Detector Control Amplifier Replacement .....	12.27
Left Engine Firewall Louver Fire/Overheat Detector Removal/Installation .....	12.28
Left Engine Firewall Louver Fire/Overheat Detector Frame Removal/Installation .....	12.29
Right Engine Firewall Louver Fire/Overheat Detector Removal/Installation .....	12.30
Right Engine Firewall Louver Fire/Overheat Detector Frame Removal/Installation .....	12.31
Main Deck Fire/Overheat Detector Removal/Installation .....	12.32
<b>SECTION III. FIRE EXTINGUISHING SYSTEM MAINTENANCE</b>	
Fire Extinguishing System Inspection .....	12.33
Pilot Engine Fire Pull Switch Removal/Installation .....	12.34
Pilot Fire Bottle Select Switch Replacement .....	12.35
CPG Engine Fire Pull Switch Removal/Installation .....	12.36



## CHAPTER INDEX - continued

<u>Para Title</u>	<u>Para No.</u>
CPG Fire Bottle Select Switch Replacement .....	12.37
Primary and Reserve Fire Extinguisher Removal .....	12.38
Primary and Reserve Fire Extinguisher Installation .....	12.39
Fire Extinguisher Cartridge Removal/Installation .....	12.40
Fire Extinguisher Electronic Module Replacement .....	12.41
Fire Extinguisher Stop Check Valve Replacement .....	12.42
No. 1 Engine Fire Extinguisher Fitting Replacement .....	12.43
No. 2 Engine Fire Extinguisher Fitting Replacement .....	12.44
Thermal Discharge Indicator Replacement .....	12.45

### **SECTION IV. ANTI-ICE/DE-ICE SYSTEM MAINTENANCE**

Anti-Ice/De-Ice System Inspection .....	12.46
Pilot Anti-Ice Panel Assembly Removal/Installation .....	12.47
Pilot Anti-Ice Panel Light Indicating Panel Removal/Installation .....	12.48
Pilot Anti-Ice Panel Switch Replacement (AVIM) .....	12.49
Pilot Anti-Ice Panel Receptacle Replacement .....	12.50
Pilot Anti-Ice Panel Light Indicating Panel Receptacle Replacement (AVIM) .....	12.51
Pilot Anti-Ice Panel Indicator Switch Replacement (AVIM) .....	12.52
CPG Auxiliary Panel Assembly Removal/Installation .....	12.53
CPG Auxiliary Panel Light Indicating Panel Removal/Installation .....	12.54
Blade De-Ice Controller Removal/Installation .....	12.55
Blade De-Ice Controller Adjustment .....	12.56
Engine Anti-Ice Relay Box Removal/Installation .....	12.57
Engine Anti-Ice Relay Box Disassembly/Assembly .....	12.58
Ice Detector Signal Processor Removal/Installation .....	12.59

CHAPTER INDEX - continued

<u>Para Title</u>	<u>Para No.</u>
Ice Detector Signal Processor Circuit Card Assembly (CCA) Stack Removal/Installation (AVIM) .....	12.60
Ice Detector Signal Processor Interconnection CCA Replacement (AVIM) .....	12.61
Ice Detector Signal Processor Probe Oscillator Reference or Rate Output CCA Replacement (AVIM) .....	12.62
Ice Detector Signal Processor Power Supply CCA Replacement (AVIM) .....	12.63
Ice Detector Signal Processor EMI Filter Replacement (AVIM) .....	12.64
Ice Detector Sensor Removal/Installation .....	12.65
Windshield Anti-Ice Temperature Control Box Removal/Installation .....	12.66
Windshield Anti-Ice Temperature Control Box Access Cover Removal/Installation (AVIM) ...	12.67
Windshield Anti-Ice Temperature Control Box Circuit Card Assembly (CCA) Removal/Installation (AVIM) .....	12.68
Windshield Anti-Ice Temperature Control Box Capacitor Replacement (AVIM) .....	12.69
Windshield Anti-Ice Temperature Control Box Relay Replacement (AVIM) .....	12.70
Windshield Anti-Ice Temperature Control Box Semiconductor Replacement (AVIM) .....	12.71
Windshield Anti-Ice Temperature Control Box Current Transformer Replacement (AVIM) ....	12.72
Windshield Anti-Ice Temperature Control Box Receptacle Replacement (AVIM) .....	12.73
Windshield Anti-Ice Temperature Control Box Terminal Stud Replacement (AVIM) .....	12.74
Outside Air Temperature Sensor Removal/Installation .....	12.75

**SECTION V. CANOPY JETTISON SYSTEM MAINTENANCE**

Canopy Jettison System Inspection .....	12.76
Canopy Severance Device Removal/Installation .....	12.77
Canopy Severance Initiator Handle Removal/Installation .....	12.78

## SECTION I. WINDSHIELD WIPER SYSTEM MAINTENANCE

---

### 12.1. WINDSHIELD WIPER SYSTEM INSPECTION

---

#### 12.1.1. Description

This task covers: Inspection.

---

#### 12.1.2. Initial Setup

##### Tools:

Aircraft mechanic's tool kit (item 376, App H)

##### Equipment Conditions:

<u>Ref</u>	<u>Condition</u>
1.57	Helicopter safed

##### Personnel Required:

67R	Attack Helicopter Repairer
67R3F	Attack Helicopter Repairer/Technical Inspector

---

#### 12.1.3. Inspection

- a. **Check windshield wiper blades for damaged rubber and worn attachment points.** None allowed.
- b. **Check windshield wiper arms for damage, worn attaching points, and loose or missing hardware.** None allowed.
- c. **Check windshield wiper links for damage, worn attaching points, and loose or missing hardware.** None allowed.
- d. **Check windshield wiper converters for damaged splines, nicks, dents, cracks, scratches, and stripped or damaged threads.** None allowed.
- e. **Check windshield wiper flex shafts for cuts, nicks, kinks, and stripped or damaged threads.** None allowed.
- f. **Check windshield wiper motors for nicks, dents, cracks, loose or missing hardware, and damaged connector.** None allowed.
- g. **Check general mounting hardware for cracks, gouges, nicks, scratches, chafing, damage, rounded flats, and stripped or damaged threads.** Replace damaged hardware.
- h. **Check windshield wiper system components for corrosion** (para 1.49).

END OF TASK

## 12.2. PILOT WINDSHIELD WIPER BLADE REPLACEMENT

### 12.2.1. Description

This task covers: Removal. Cleaning. Inspection. Installation.

### 12.2.2. Initial Setup

#### Tools:

Aircraft mechanic's tool kit (item 376, App H)  
 0.0 - 50.0-pound weighing scale (item 273, App H)

#### References:

TM 1-1520-238-T

#### Personnel Required:

67R Attack Helicopter Repairer  
 67R3F Attack Helicopter Repairer/Technical Inspector

#### Equipment Conditions:

Ref	Condition
1.57	Helicopter safed

### 12.2.3. Removal

- Enter pilot station (para 1.56). Observe all safety precautions.
- On pilot aft circuit breaker panel, open ECS WSHLD WPR circuit breaker.

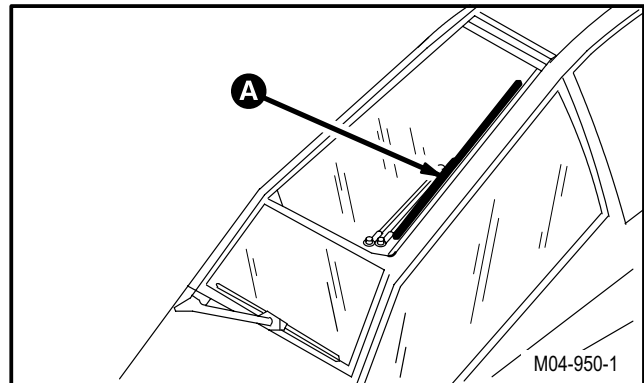

- Remove wiper blade (1) from wiper arm (2) and wiper link (3).

- Remove nuts (4) and (5) and washers (6) and (7) from studs (8) and (9).
- Lift arm (2) and link (3) from studs (8) and (9).
- Remove and discard blade (1).

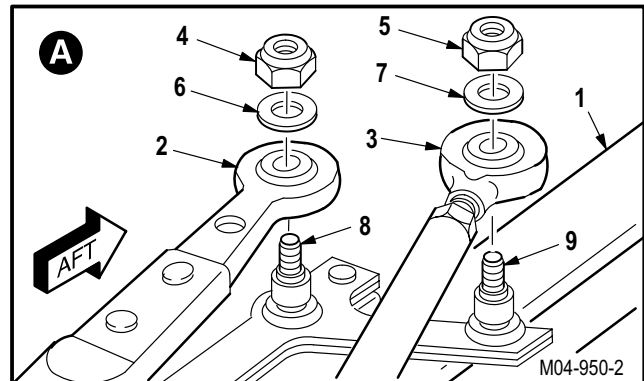

GO TO NEXT PAGE

---

**12.2. PILOT WINDSHIELD WIPER BLADE REPLACEMENT - continued**

---

12.2.4. Cleaning

- a. **Wipe attaching parts with a clean rag.**

12.2.5. Inspection

- a. **Check nuts for stripped or damaged threads** (para 12.1).
- b. **Check attaching parts for corrosion** (para 1.49).

12.2.6. Installation

- a. **Install new blade (1) on arm (2) and link (3).**

- (1) Install arm (2) on stud (8).
- (2) Install link (3) on stud (9).
- (3) Install washer (6) and nut (4) on stud (8).
- (4) Install washer (7) and nut (5) on stud (9).

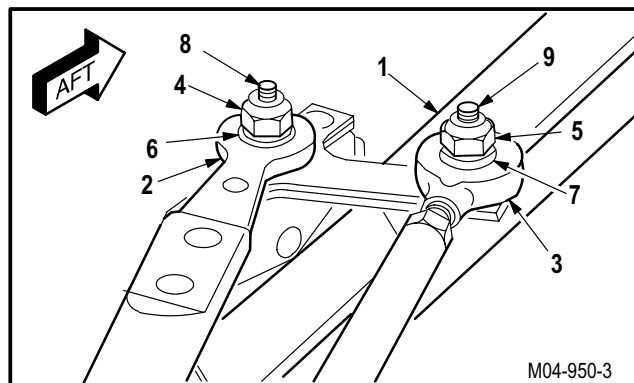

- b. **Adjust blade tension to 10 POUNDS.**

- (1) Check tension of blade (1) at end of arm (2). Use scale.
- (2) Adjust tension to **10 POUNDS**.
- (3) Tighten nut (10) to increase tension. Loosen nut (10) to decrease tension.

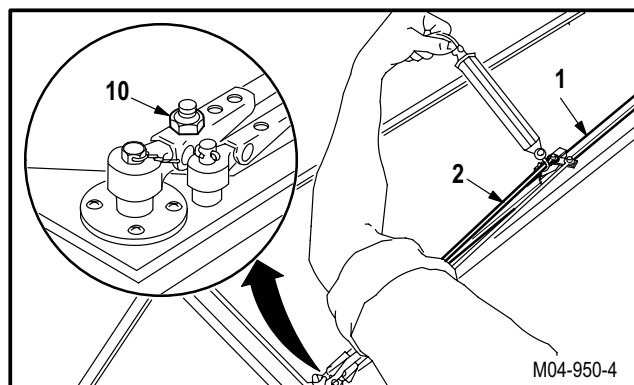

- c. **Inspect (QA).**

- d. **Perform windshield wipers maintenance operational check** (TM 1-1520-238-T).

END OF TASK

### 12.3. PILOT WINDSHIELD WIPER ARM REPLACEMENT

#### 12.3.1. Description

This task covers: Removal. Cleaning. Inspection. Installation.

#### 12.3.2. Initial Setup

##### Tools:

Aircraft mechanic's tool kit (item 376, App H)  
 0.0 - 50.0-pound weighing scale (item 273, App H)

##### References:

TM 1-1520-238-T

##### Materials/Parts:

Wire (item 229, App F)

##### Personnel Required:

67R Attack Helicopter Repairer  
 67R3F Attack Helicopter Repairer/Technical Inspector

##### Equipment Conditions:

Ref	Condition
1.57	Helicopter safed
1.70	External electrical power applied

#### 12.3.3. Removal

- a. Enter pilot station (para 1.56). Observe all safety precautions.
- b. On pilot aft circuit breaker panel, close ECS WSHLD WPR circuit breaker.
- c. On pilot ANTI-ICE control panel, set WSHLD WIPER switch to PARK, hold, and release.
- d. Remove external electrical power (para 1.70).
- e. On pilot aft circuit breaker panel, open ECS WSHLD WPR circuit breaker.
- f. Remove wiper arm (1) from wiper blade stud (2).
  - (1) Remove nut (3) and washer (4).
  - (2) Remove arm (1) from stud (2).

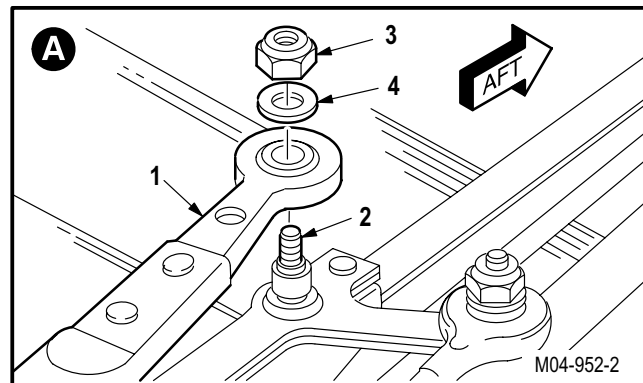
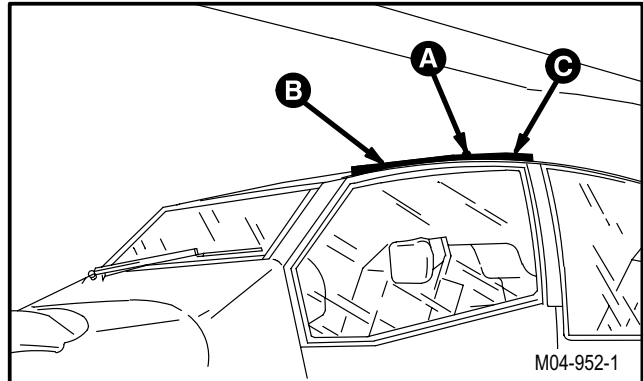

GO TO NEXT PAGE

---

**12.3. PILOT WINDSHIELD WIPER ARM REPLACEMENT - continued**



---

**NOTE**

Spacer can fall out when wiper arm is removed.

g. **Remove arm (1) from wiper converter shaft (5).**

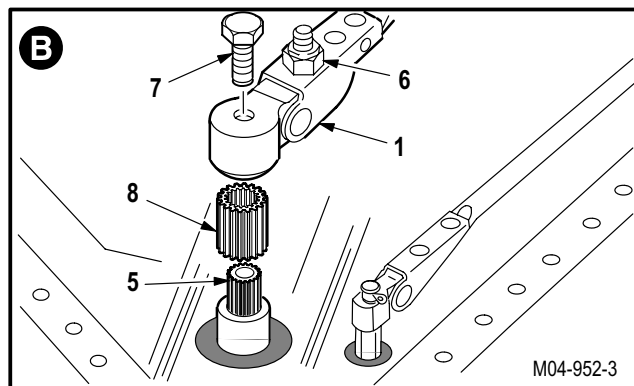
- (1) Loosen nut (6) to release tension on arm (1).
- (2) Remove lockwire from bolt (7).
- (3) Remove bolt (7).
- (4) Remove and discard arm (1) and spacer (8) from shaft (5).



12.3.4. Cleaning

- a. **Wipe removed and attaching parts with a clean rag.**

12.3.5. Inspection

- a. **Check stud, nut, shaft, and bolt for stripped or damaged threads (para 12.1).**
- b. **Check removed and attaching parts for corrosion (para 1.49).**

12.3.6. Installation

- a. **Install new arm (1) on stud (2).**

- (1) Position arm (1) on stud (2).
- (2) Install washer (4) and nut (3).

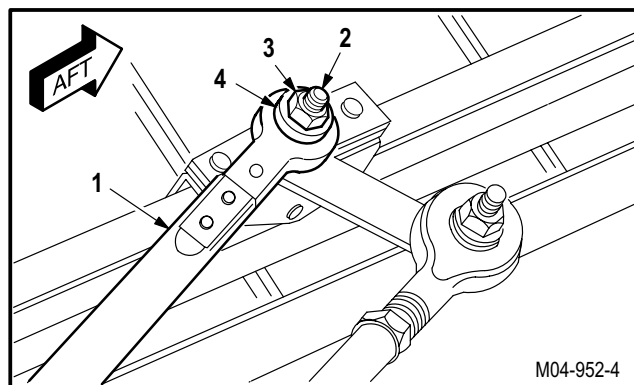

GO TO NEXT PAGE

12.3. PILOT WINDSHIELD WIPER ARM REPLACEMENT - continued

**NOTE**

To ensure proper installation of wiper, spacer must be installed between wiper arm and converter. Spacer can fall out when wiper arm is removed.

**b. Install arm (1) on shaft (5).**

- (1) Install new spacer (8) and arm (1) on shaft (5).
- (2) Adjust arm (1) on shaft (5) until end of blade (9) is **0.50 INCH** from left edge of canopy frame (10).

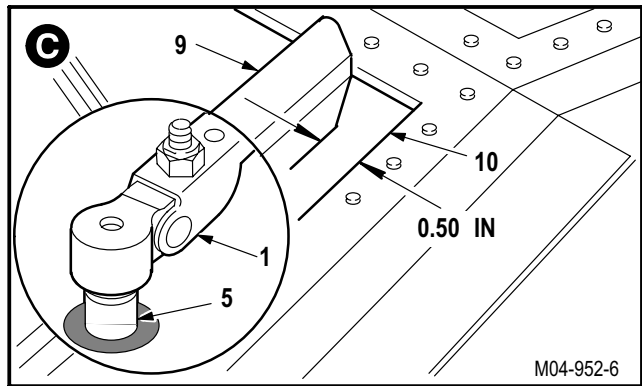
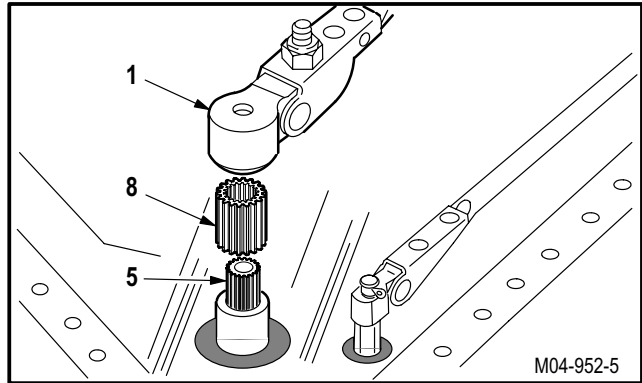

- (3) Install bolt (7) through arm (1) on shaft (5).
- (4) Lockwire bolt (7) to arm (1). Use wire (item 229, App F).

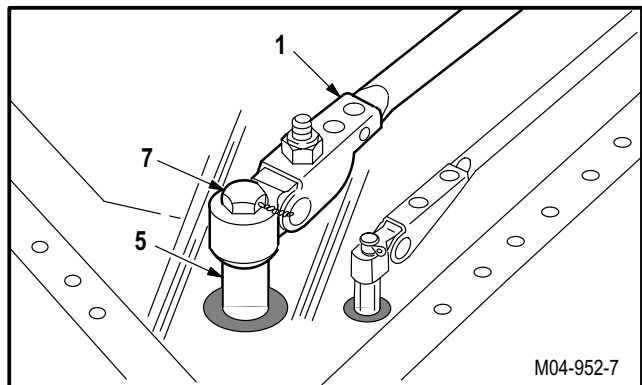

**c. Adjust blade tension to 10 POUNDS.**

- (1) Check tension of blade (9) at end of arm (1). Use scale.
- (2) Adjust tension to **10 POUNDS**.
- (3) Tighten nut (6) to increase tension. Loosen nut (6) to decrease tension.

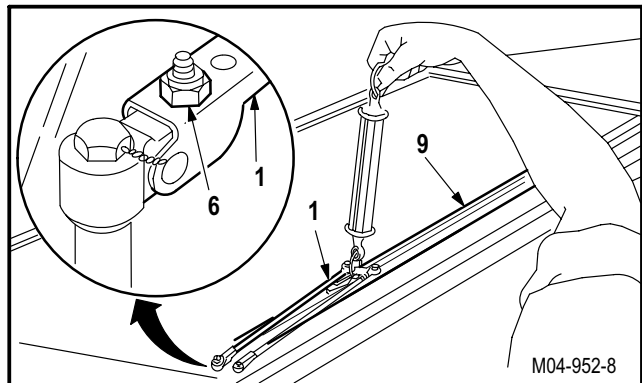

**d. Inspect (QA).**

**e. Perform windshield wipers maintenance operational check (TM 1-1520-238-T).**

END OF TASK



**12.4. PILOT WINDSHIELD WIPER LINK REPLACEMENT**

12.4.1. Description

This task covers: Removal. Cleaning. Inspection. Installation.

12.4.2. Initial Setup

**Tools:**

Aircraft mechanic's tool kit (item 376, App H)

**References:**

TM 1-1520-238-T

**Materials/Parts:**

Cotter pin

**Personnel Required:**

67R Attack Helicopter Repairer  
 67R3F Attack Helicopter Repairer/Technical Inspector

**Equipment Conditions:**

Ref	Condition
1.57	Helicopter safed

12.4.3. Removal

- a. **Enter pilot station (para 1.56). Observe all safety precautions.**
- b. **On pilot aft circuit breaker panel, open ECS WSHLD WPR circuit breaker.**

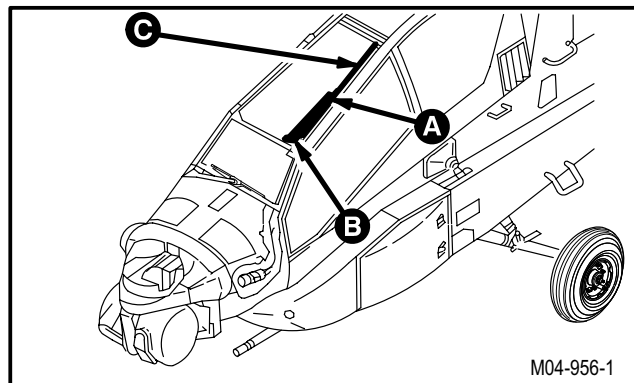

- c. **Remove wiper link (1) from wiper blade stud (2).**

- (1) Remove nut (3) and washer (4).
- (2) Remove link (1) from stud (2).

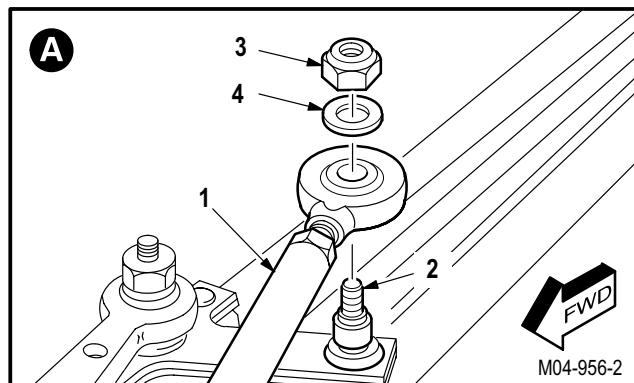

GO TO NEXT PAGE

**12.4. PILOT WINDSHIELD WIPER LINK REPLACEMENT - continued**

**d. Remove link (1) from pivot stud (5).**

- (1) Remove and discard cotter pin (6).
- (2) Remove link (1) from stud (5).

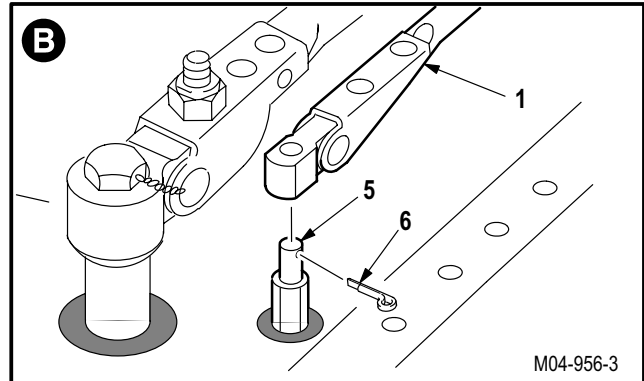

**e. Measure and record distance A from center of rod end (7) to bottom of nut (8).**

**f. Discard link (1).**

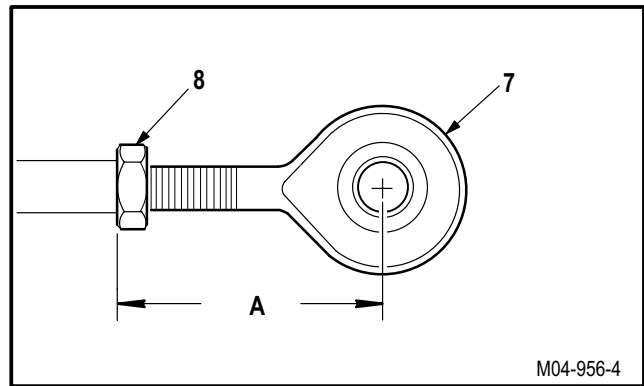

**12.4.4. Cleaning**

- a. Wipe attaching parts with a clean rag.**

**12.4.5. Inspection**

- a. Check studs and nut for stripped or damaged threads (para 12.1).**
- b. Check attaching parts for corrosion (para 1.49).**

**12.4.6. Installation**

**a. Adjust rod end (7) on new link (1) to distance A recorded in paragraph 12.4.3.**

- (1) Loosen nut (8). Adjust rod end (7).
- (2) Hold rod end (7) parallel with mating surface. Tighten nut (8).

GO TO NEXT PAGE

**12.4. PILOT WINDSHIELD WIPER LINK REPLACEMENT - continued****b. Install link (1) on stud (5).**

- (1) Position link (1) on stud (5).
- (2) Install new cotter pin (6).

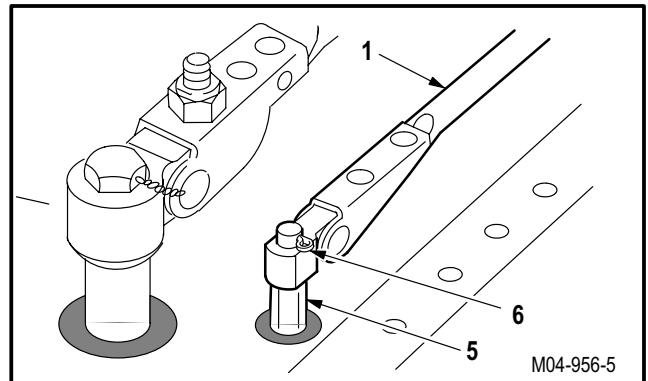
**c. Install link (1) on stud (2).**

- (1) Position link (1) on stud (2).
- (2) Install washer (4) and nut (3).

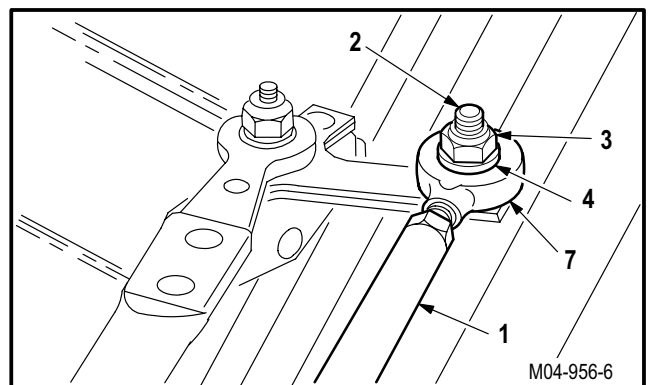
**d. Check for 0.50 INCH clearance between edge of blade (9) and canopy frame (10).**

- (1) Adjust rod end (7) to obtain **0.50 INCH** clearance between upper and lower edges of blade (9) and canopy frame (10).

**e. Inspect (QA).**

- f. **Perform windshield wipers maintenance operational check (TM 1-1520-238-T).**

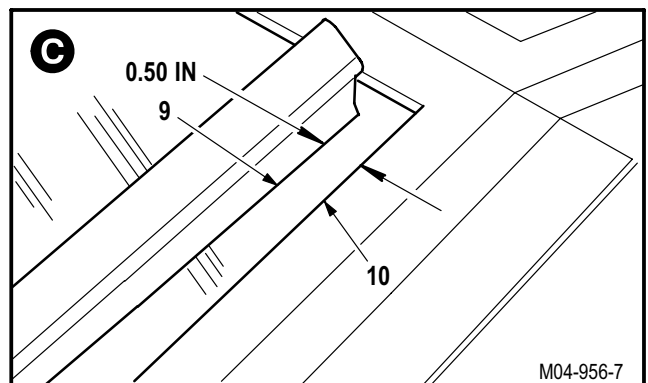

END OF TASK

---

## 12.5. PILOT WINDSHIELD WIPER CONVERTER REPLACEMENT

---

### 12.5.1. Description

This task covers: Removal. Cleaning. Inspection. Installation.

---

### 12.5.2. Initial Setup

#### Tools:

Aircraft mechanic's tool kit (item 376, App H)  
Light duty laboratory apron (item 27, App H)  
Chemical protective gloves (item 154, App H)  
Adjustable air filtering respirator (item 262, App H)  
30 - 150 inch-pound 1/4-inch drive click type torque wrench (item 435, App H)

#### Materials/Parts:

Protective cap  
Brush (item 34, App F)  
Sealing compound (item 175, App F)  
Wire (item 229, App F)

#### Personnel Required:

67R Attack Helicopter Repairer  
67R3F Attack Helicopter Repairer/Technical Inspector

#### References:

TM 1-1520-238-T

#### Equipment Conditions:

<u>Ref</u>	<u>Condition</u>
1.57	Helicopter safed
12.3	Pilot windshield wiper arm removed
12.4	Pilot windshield wiper link removed

---

### 12.5.3. Removal

- a. **Enter pilot station** (para 1.56). **Observe all safety precautions.**
- b. **On pilot aft circuit breaker panel, open ECS WSHLD WPR circuit breaker.**

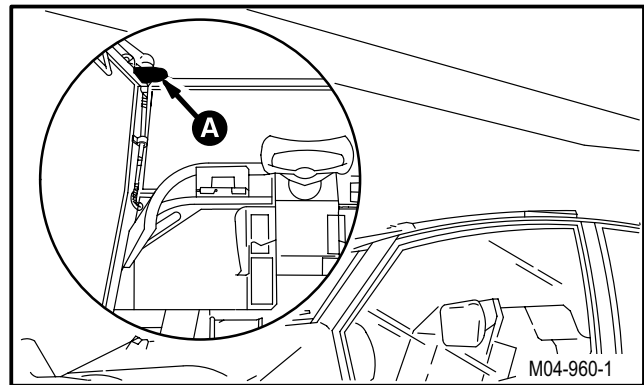

GO TO NEXT PAGE

## 12.5. PILOT WINDSHIELD WIPER CONVERTER REPLACEMENT - continued

### c. Remove wiper converter (1) from canopy crossbeam (2).

- (1) Remove lockwire from three bolts (3).
- (2) Remove three bolts (3) and washers (4).
- (3) Remove converter (1) and three spacers (5).

#### NOTE

The coupling can fall out when flex shaft is removed.

### d. Remove wiper flex shaft (6) from converter (1).

- (1) Remove lockwire from nut (7) and converter (1).
- (2) Remove nut (7) and coupling (8) from converter (1).
- (3) Remove flex shaft (6).
- (4) Install protective cap (9) on nut (7).
- (5) Discard converter (1).

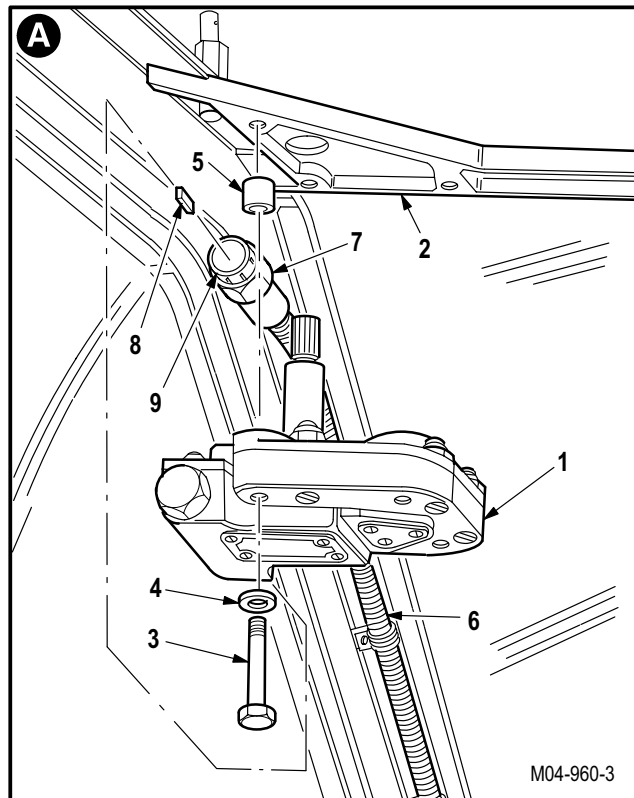

#### 12.5.4. Cleaning

- a. **Wipe removed and attaching parts with a clean rag.**
- b. **Clean sealing compound from crossbeam** (para 1.47).

#### 12.5.5. Inspection

- a. **Check flex shaft nut and bolts for stripped or damaged threads** (para 12.1).
- b. **Check removed and attaching parts for corrosion** (para 1.49).

GO TO NEXT PAGE

**12.5. PILOT WINDSHIELD WIPER CONVERTER REPLACEMENT - continued**

12.5.6. Installation

**NOTE**

To ensure proper installation of flex shaft, coupling must be installed between flex shaft and converter fitting.

**a. Install flex shaft (6) on new converter (1). Torque nut (7) to 100 INCH-POUNDS.**

- (1) Remove protective cap (9) from nut (7).
- (2) Install coupling (8) and nut (7) on converter (1).
- (3) Torque nut (7) to **100 INCH-POUNDS**. Use torque wrench.
- (4) Lockwire nut (7) to converter (1). Use wire (item 229, App F).

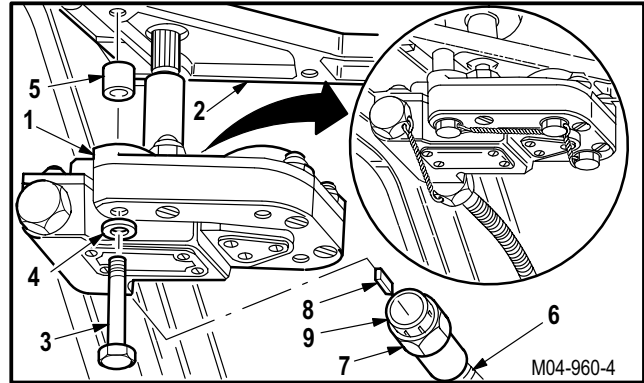

**b. Install converter (1) on canopy crossbeam (2).**

- (1) Position converter (1) on crossbeam (2).
- (2) Install three bolts (3) through washers (4), converter (1), and spacers (5).
- (3) Lockwire three bolts (3) together. Use wire (item 229, App F).

GO TO NEXT PAGE

---

**12.5. PILOT WINDSHIELD WIPER CONVERTER REPLACEMENT - continued**

---



- c. **Apply sealing compound around converter shaft (10).** Use sealing compound (item 175, App F) and brush (item 34, App F).
- d. **Inspect (QA).**
- e. **Install pilot windshield wiper arm** (para 12.3).
- f. **Install pilot windshield wiper link** (para 12.4).
- g. **Perform windshield wipers maintenance operational check** (TM 1-1520-238-T).

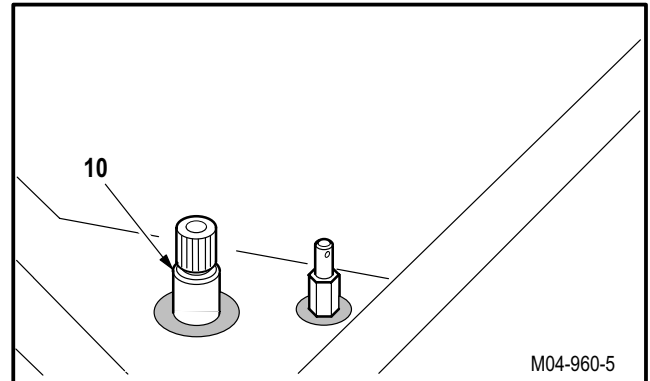

END OF TASK

**12.6. PILOT WINDSHIELD WIPER FLEX SHAFT REPLACEMENT**

12.6.1. Description

This task covers: Removal. Cleaning. Inspection. Installation.

12.6.2. Initial Setup

**Tools:**

Aircraft mechanic's tool kit (item 376, App H)  
 30 - 150 inch-pound 1/4-inch drive click type torque wrench (item 435, App H)

**References:**

TM 1-1520-238-T

**Materials/Parts:**

Strap (item 193, App F) (2)  
 Wire (item 229, App F)

**Equipment Conditions:**

**Personnel Required:**

67R Attack Helicopter Repairer  
 67R3F Attack Helicopter Repairer/Technical Inspector

<u>Ref</u>	<u>Condition</u>
1.57	Helicopter safed
2.2	Access cover L40 removed
8.21	Signal data converter tray removed

12.6.3. Removal

- a. **Enter pilot station** (para 1.56). **Observe all safety precautions.**
- b. **On pilot aft circuit breaker panel, open ECS WSHLD WPR circuit breaker.**

**NOTE**

The coupling can fall out when flex shaft is removed.

- c. **Remove wiper flex shaft (1) from wiper motor (2).**

- (1) Remove lockwire from nut (3) and motor (2).
- (2) Remove nut (3) and coupling (4) from motor (2).
- (3) Remove flex shaft (1).

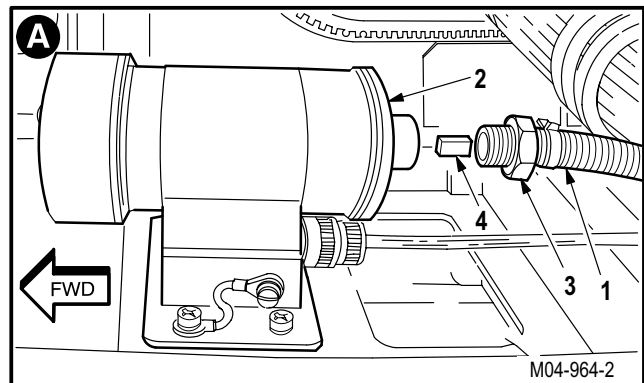
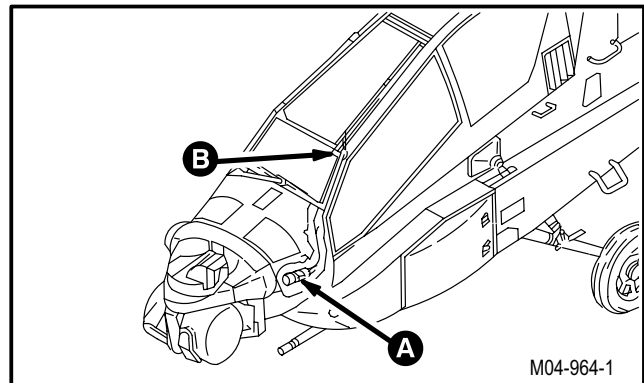

GO TO NEXT PAGE



---

**12.6. PILOT WINDSHIELD WIPER FLEX SHAFT REPLACEMENT - continued**

---

**NOTE**

The coupling can fall out when flex shaft is removed.

**d. Remove flex shaft (1) from wiper converter (5) and canopy frame (6).**

- (1) Remove lockwire from nut (7) and converter (5).
- (2) Remove nut (7) and coupling (8) from converter (5).
- (3) Remove screw (9), clamp (10), and spacer (11) from canopy frame (6).
- (4) Remove clamp (10) from flex shaft (1).
- (5) Remove flex shaft (1) from access hole (12).

**e. Remove sleeving (13) from flex shaft (1).**

- (1) Remove two straps (14).
- (2) Remove sleeving (13).
- (3) Discard flex shaft (1).

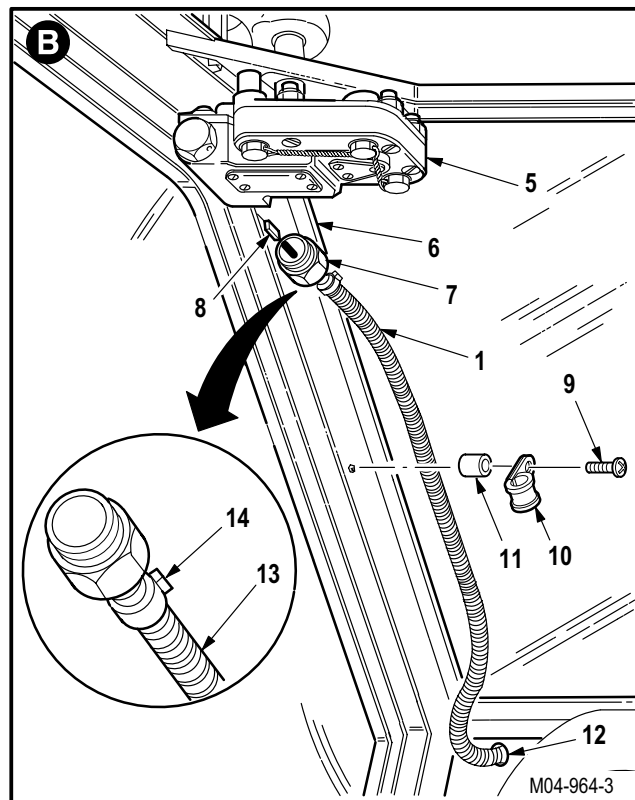

**12.6.4. Cleaning**

- a. **Wipe removed and attaching parts with a clean rag.**

**12.6.5. Inspection**

- a. **Check nuts for stripped or damaged threads (para 12.1).**
- b. **Check removed and attaching parts for corrosion (para 1.49).**

GO TO NEXT PAGE

**12.6. PILOT WINDSHIELD WIPER FLEX SHAFT REPLACEMENT - continued**

12.6.6. Installation

**a. Install sleeving (13) on new flex shaft (1).**

- (1) Install sleeving (13) on flex shaft (1).
- (2) Secure sleeving (13) with two straps (14). Use strap (item 193, App F).

**NOTE**

To ensure proper installation of flex shaft, coupling must be installed between flex shaft and converter fitting.

**b. Install flex shaft (1) on converter (5) and canopy frame (6). Torque nut (7) to 100 INCH-POUNDS.**

- (1) Install flex shaft (1) through access hole (12).
- (2) Install coupling (8) and nut (7) on converter (5).
- (3) Torque nut (7) to **100 INCH-POUNDS**. Use torque wrench.
- (4) Lockwire nut (7) to converter (5). Use wire (item 229, App F).
- (5) Install clamp (10) on flex shaft (1).
- (6) Install screw (9) through clamp (10) and spacer (11) on canopy frame (6).

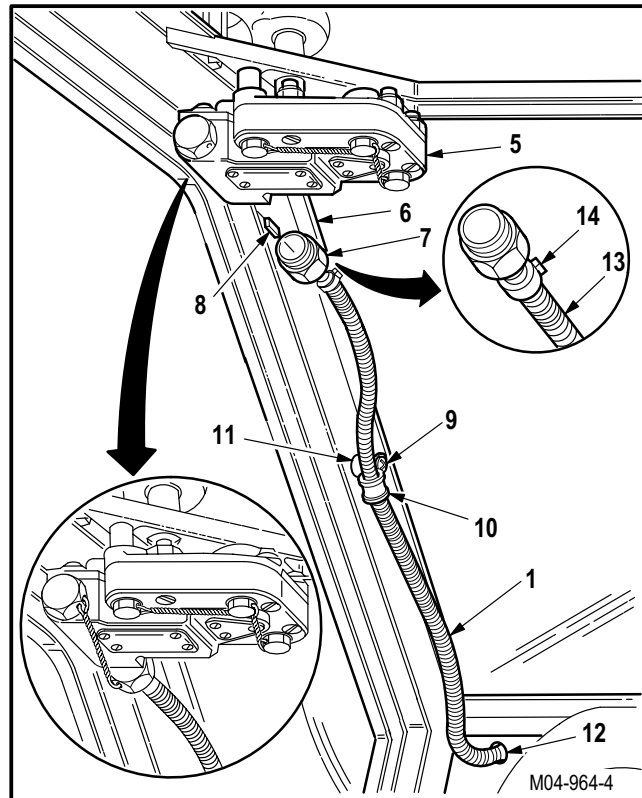

GO TO NEXT PAGE

---

**12.6. PILOT WINDSHIELD WIPER FLEX SHAFT REPLACEMENT - continued**

---

**NOTE**

To ensure proper installation of flex shaft, coupling must be installed between flex shaft and motor fitting.

- c. **Install flex shaft (1) on motor (2).** Torque nut (3) to **100 INCH-POUNDS**.

(1) Install coupling (4) and nut (3) on motor (2).

(2) Torque nut (3) to **100 INCH-POUNDS**. Use torque wrench.

(3) Lockwire nut (3) to motor (2). Use wire (item 229, App F).

- d. **Inspect (QA).**

- e. **Perform windshield wipers maintenance operational check** (TM 1-1520-238-T).

- f. **Install signal data converter tray** (para 8.21).

- g. **Install access cover L40** (para 2.2).

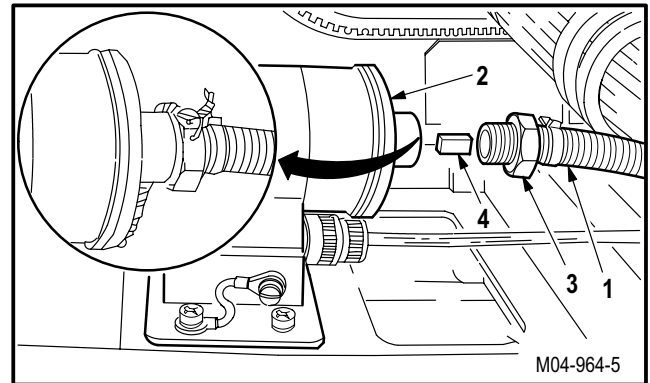

END OF TASK

---

## 12.7. PILOT WINDSHIELD WIPER MOTOR REPLACEMENT

---

### 12.7.1. Description

This task covers: Removal. Cleaning. Inspection. Installation.

---

### 12.7.2. Initial Setup

#### Tools:

Aircraft mechanic's tool kit (item 376, App H)  
Light duty laboratory apron (item 27, App H)  
Chemical protective gloves (item 154, App H)  
Adjustable air filtering respirator (item 262, App H)  
30 - 150 inch-pound 1/4-inch drive click type torque wrench (item 435, App H)

#### Materials/Parts:

Protective cap  
Brush (item 34, App F)  
Sealing compound (item 175, App F)  
Wire (item 229, App F)

#### Personnel Required:

67R Attack Helicopter Repairer  
67R3F Attack Helicopter Repairer/Technical Inspector

#### References:

TM 1-1520-238-T

#### Equipment Conditions:

<u>Ref</u>	<u>Condition</u>
1.57	Helicopter safed
2.2	Access cover L40 removed
8.21	Signal data converter tray removed

---

### 12.7.3. Removal

- a. **Enter pilot station** (para 1.56). **Observe all safety precautions.**
- b. **On pilot aft circuit breaker panel, open ECS WSHLD WPR circuit breaker.**

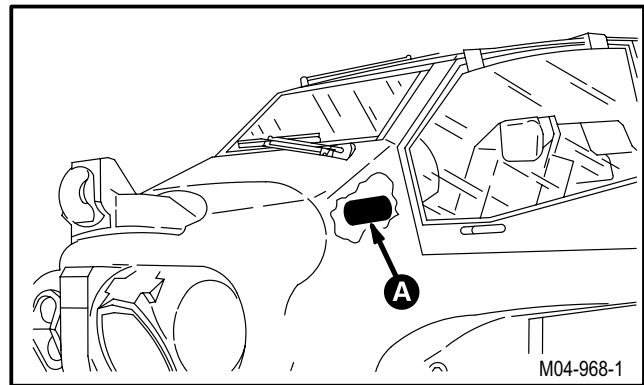

GO TO NEXT PAGE

---

**12.7. PILOT WINDSHIELD WIPER MOTOR REPLACEMENT - continued**



---

**NOTE**

The coupling can fall out when flex shaft is removed.

**c. Remove wiper flex shaft (1) from wiper motor (2).**

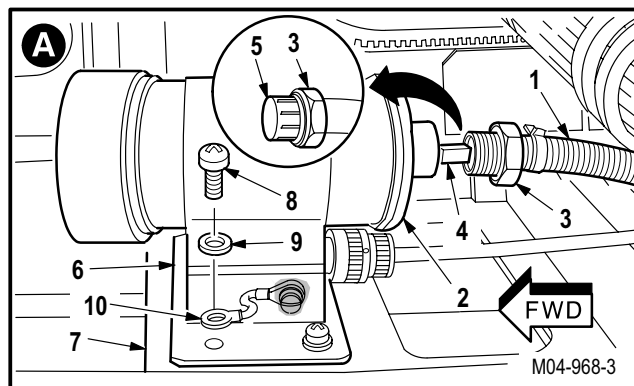
- (1) Remove lockwire from motor (2) and nut (3).
- (2) Remove nut (3) and coupling (4) from motor (2).
- (3) Install protective cap (5) on nut (3).



**d. Remove motor (2) and mounting plate (6) from bracket (7).**

- (1) Remove sealant from screw (8), washer (9), and lead (10) (para 1.47).
- (2) Remove screw (8), washer (9), and lead (10).
- (3) Remove three screws (11) and washers (12).
- (4) Remove motor (2) and plate (6).

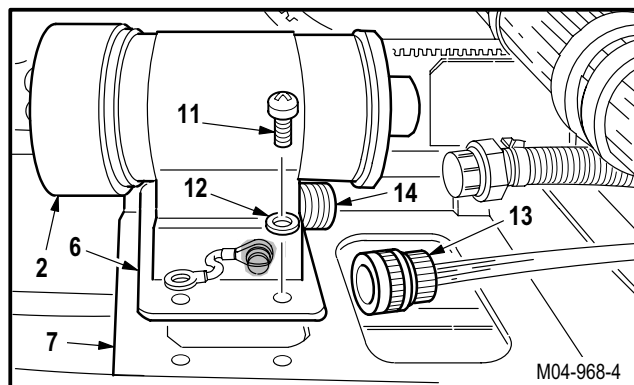

**e. Detach connector P289 (13) from receptacle (B4)J1 (14).**

**f. Remove plate (6) from motor (2).**

- (1) Remove lockwire from four bolts (15).
- (2) Remove four bolts (15) and washers (16) from plate (6).
- (3) Remove plate (6).

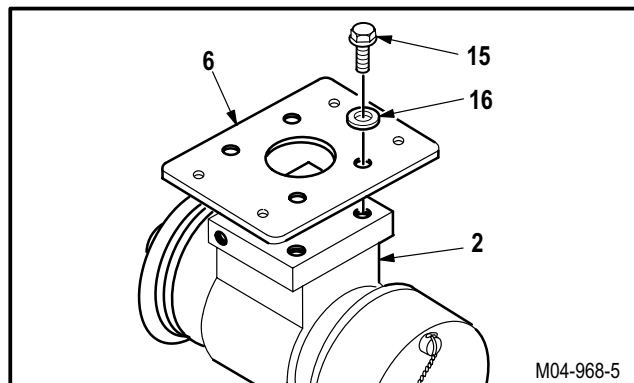

GO TO NEXT PAGE

**12.7. PILOT WINDSHIELD WIPER MOTOR REPLACEMENT - continued**

12.7.4. Cleaning

- a. **Wipe removed and attaching parts with a clean rag.**

12.7.5. Inspection

- a. **Check flex shaft nut for stripped or damaged threads** (para 12.1).
- b. **Check removed and attaching parts for corrosion** (para 1.49).

12.7.6. Installation

- a. **Install plate (6) on new motor (2).**

- (1) Position plate (6) on motor (2).
- (2) Install four bolts (15) and washers (16).
- (3) Lockwire four bolts (15) in pairs. Use wire (item 229, App F).

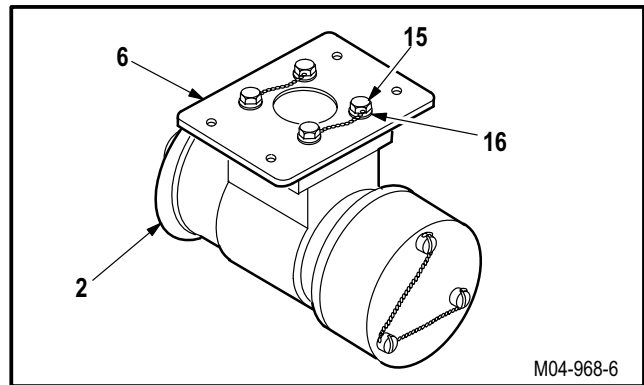

- b. **Attach connector P289 (13) to receptacle (B4)J1 (14).**

- c. **Install motor (2) and plate (6) on bracket (7).**

- (1) Position plate (6) on bracket (7).
- (2) Install three screws (11) and washers (12) on plate (6).
- (3) Install screw (8), washer (9), and lead (10) on plate (6).

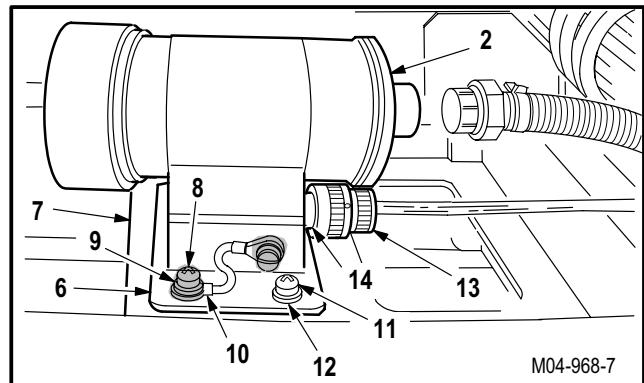

- d. **Apply sealing compound on screw (8), washer (9), and lead (10).** Use sealing compound (item 175, App F) and brush (item 34, App F).

GO TO NEXT PAGE

---

**12.7. PILOT WINDSHIELD WIPER MOTOR REPLACEMENT - continued**



---

**NOTE**

To ensure proper installation of flex shaft, coupling must be installed between flex shaft and motor fitting.

- e. **Install flex shaft (1) on motor (2).** Torque nut (3) to **100 INCH-POUNDS**.

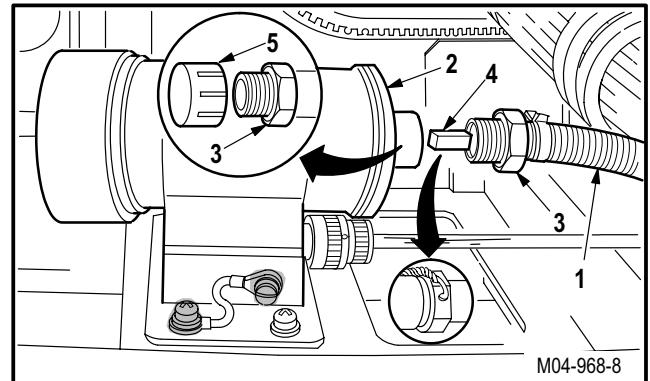
- (1) Remove protective cap (5) from nut (3).
- (2) Install coupling (4) and nut (3) on motor (2).
- (3) Torque nut (3) to **100 INCH-POUNDS**. Use torque wrench.
- (4) Lockwire nut (3) to motor (2). Use wire (item 229, App F).



- f. **Inspect (QA).**
- g. **Verify pilot windshield wiper alignment** (para 12.8).
- h. **Perform windshield wipers maintenance operational check** (TM 1-1520-238-T).
- i. **Install signal data converter tray** (para 8.21).
- j. **Install access cover L40** (para 2.2).

END OF TASK

## 12.8. PILOT WINDSHIELD WIPER ALINEMENT

### 12.8.1. Description

This task covers: Removal. Cleaning. Inspection. Installation.

### 12.8.2. Initial Setup

#### Tools:

Aircraft mechanic's tool kit (item 376, App H)  
0.0 - 50.0-pound weighing scale (item 273, App H)

#### References:

TM 1-1520-238-T

#### Materials/Parts:

Cotter Pin  
Wire (item 229, App F)

#### Personnel Required:

67R Attack Helicopter Repairer  
67R3F Attack Helicopter Repairer/Technical Inspector

#### Equipment Conditions:

<u>Ref</u>	<u>Condition</u>
1.57	Helicopter safed
1.70	External electrical power applied

### 12.8.3. Removal

- a. **Enter pilot station (para 1.56). Observe all safety precautions.**
- b. **On pilot aft circuit breaker panel, close ECS WSHLD WPR circuit breaker.**
- c. **On pilot ANTI-ICE control panel, set WSHLD WIPER switch to PARK, hold, and release.**
- d. **Remove external electrical power (para 1.70).**
- e. **On pilot aft circuit breaker panel, open ECS WSHLD WPR circuit breaker.**

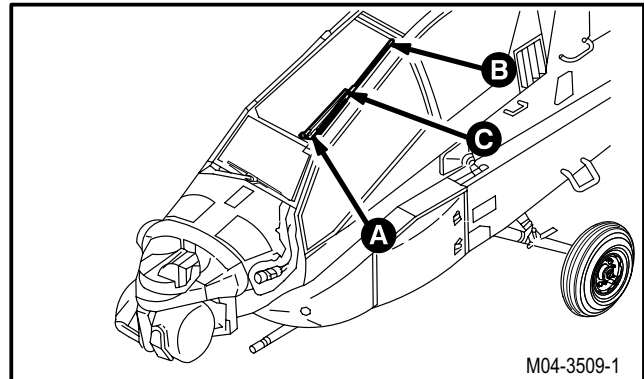

GO TO NEXT PAGE



---

**12.8. PILOT WINDSHIELD WIPER ALINEMENT - continued**



---

**NOTE**

Spacer can fall out when wiper arm is removed.

**f. Remove wiper arm (1) from wiper converter shaft (2).**

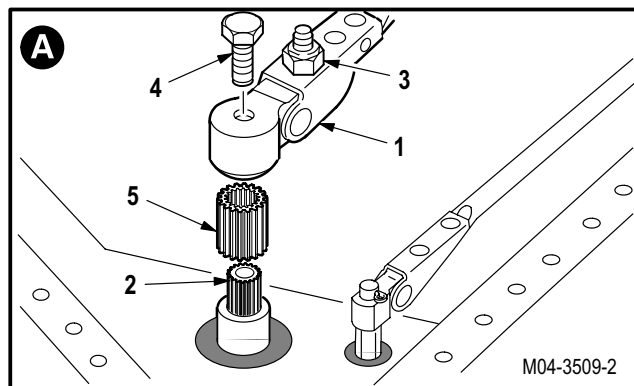
- (1) Loosen nut (3) to release tension on arm (1).
- (2) Remove lockwire from bolt (4).
- (3) Remove bolt (4).
- (4) Remove arm (1) and spacer (5) from shaft (2).



**g. Remove wiper link (6) from pivot stud (7).**

- (1) Remove and discard cotter pin (8).
- (2) Remove link (6) from stud (7).

12.8.4. Cleaning

- a. **Wipe removed and attaching parts with a clean rag.**

12.8.5. Inspection

- a. **Check studs, nuts, shaft, and bolts for stripped or damaged threads** (para 12.1).

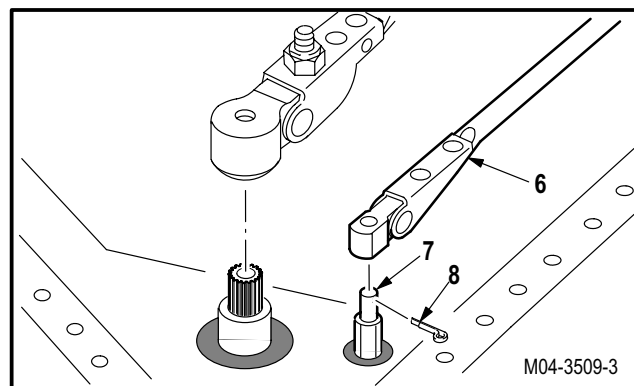

GO TO NEXT PAGE

**12.8. PILOT WINDSHIELD WIPER ALINEMENT - continued**

12.8.6. Installation

**NOTE**

To ensure proper installation of wiper, spacer must be installed between wiper arm and converter. Spacer can fall out when wiper arm is removed.

**a. Install arm (1) on shaft (2).**

- (1) Install spacer (5) and arm (1) on shaft (2).

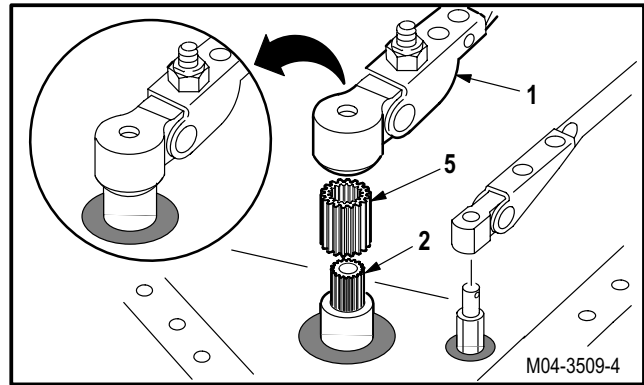

- (2) Adjust arm (1) on shaft (2) until end of blade (9) is **0.50 INCH** from left edge of canopy frame (10).

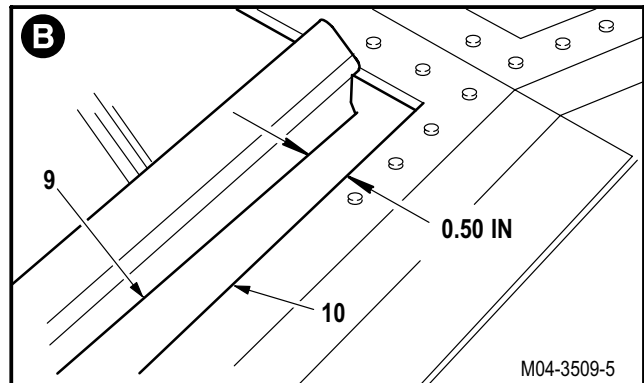

- (3) Install bolt (4) through arm (1) on shaft (2).

- (4) Lockwire bolt (4) to arm (1). Use wire (item 229, App F).

**b. Install link (6) on stud (7).**

- (1) Position link (6) on stud (7).

- (2) Install new cotter pin (8).

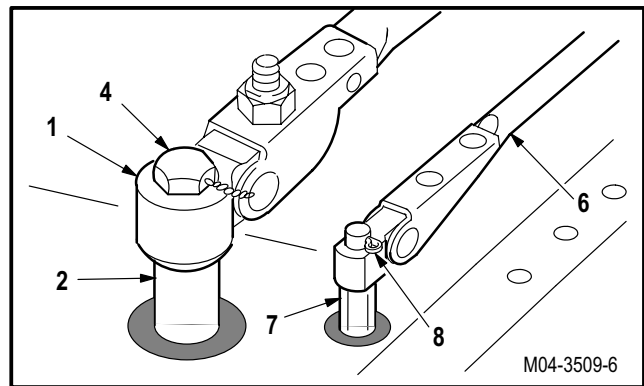

GO TO NEXT PAGE

**12.8. PILOT WINDSHIELD WIPER ALINEMENT - continued**

- (3) Check for **0.50 INCH** clearance between edge of blade (9) and canopy frame (10).

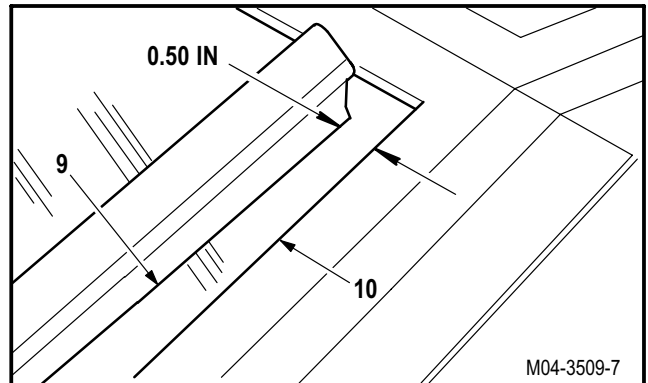

- (4) Adjust rod end (11) to obtain **0.50 INCH** clearance between upper and lower edges of blade (9) and canopy frame (10).

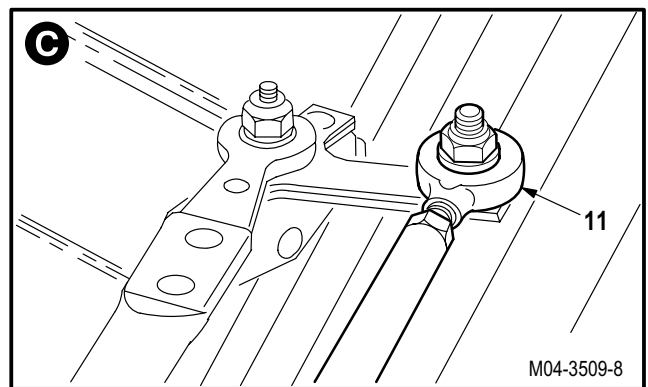

**c. Adjust blade tension to 10 POUNDS.**

- (1) Check tension of blade (9) at end of arm (1). Use scale.
- (2) Adjust tension to **10 POUNDS**.
- (3) Tighten nut (3) to increase tension. Loosen nut (3) to decrease tension.

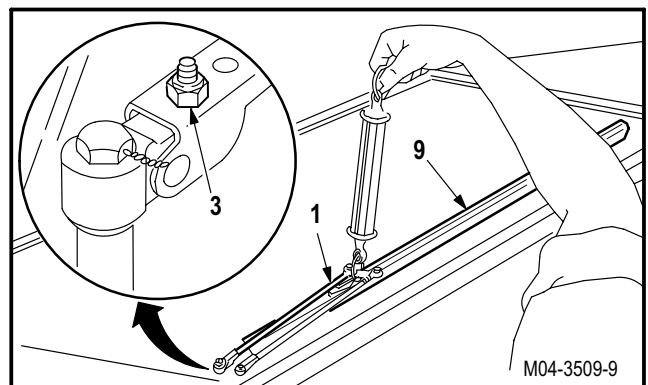

**d. Inspect (QA).**

- e. **Perform windshield wipers maintenance operational check (TM 1-1520-238-T).**

END OF TASK

**12.9. CPG WINDSHIELD WIPER BLADE REPLACEMENT**

12.9.1. Description

This task covers: Removal. Cleaning. Inspection. Installation.

12.9.2. Initial Setup

**Tools:**

Aircraft mechanic's tool kit (item 376, App H)  
 0.0 - 50.0-pound weighing scale (item 273, App H)

**References:**

TM 1-1520-238-T

**Personnel Required:**

67R Attack Helicopter Repairer  
 67R3F Attack Helicopter Repairer/Technical Inspector

**Equipment Conditions:**

<u>Ref</u>	<u>Condition</u>
1.57	Helicopter safed

12.9.3. Removal

- a. **Enter pilot station** (para 1.56). **Observe all safety precautions.**
- b. **On pilot aft circuit breaker panel, open ECS WSHLD WPR circuit breaker.**

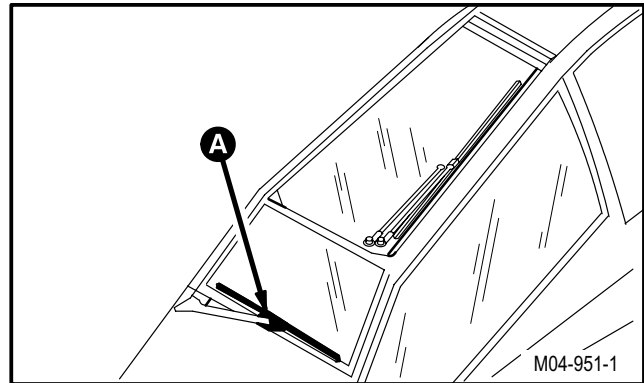

- c. **Remove wiper blade (1) from wiper arm (2) and wiper link (3).**

- (1) Remove nuts (4) and (5) and washers (6) and (7) from studs (8) and (9).
- (2) Lift arm (2) and link (3) from studs (8) and (9).
- (3) Remove and discard blade (1).

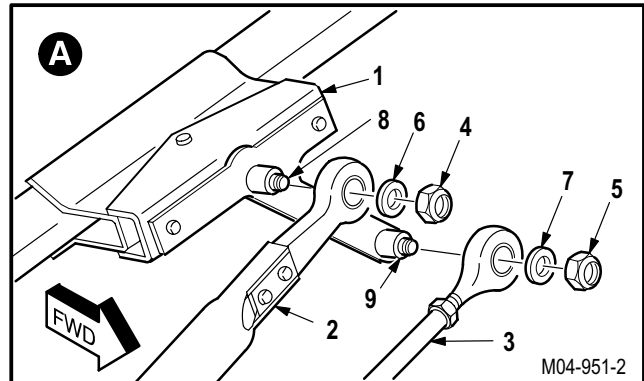

GO TO NEXT PAGE

---

**12.9. CPG WINDSHIELD WIPER BLADE REPLACEMENT - continued**

---

12.9.4. Cleaning

- a. **Wipe attaching parts with a clean rag.**

12.9.5. Inspection

- a. **Check nuts for stripped or damaged threads** (para 12.1).
- b. **Check attaching parts for corrosion** (para 1.49).

12.9.6. Installation

- a. **Install new blade (1) on arm (2) and link (3).**

- (1) Install arm (2) on stud (8).
- (2) Install link (3) on stud (9).
- (3) Install washer (6) and nut (4) on stud (8).
- (4) Install washer (7) and nut (5) on stud (9).

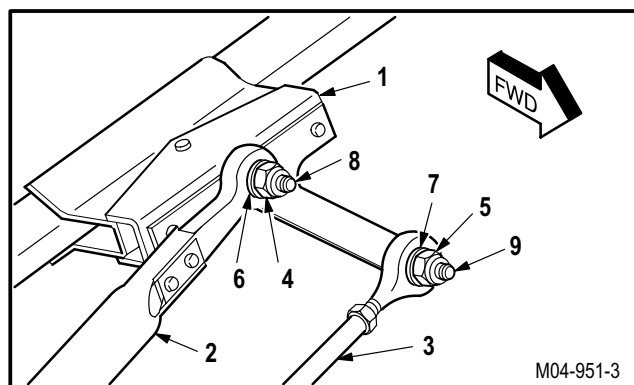

- b. **Adjust blade tension to 8 POUNDS.**

- (1) Check tension of blade (1) at end of arm (2). Use scale.
- (2) Adjust tension to **8 POUNDS**.
- (3) Tighten nut (10) to increase tension. Loosen nut (10) to decrease tension.

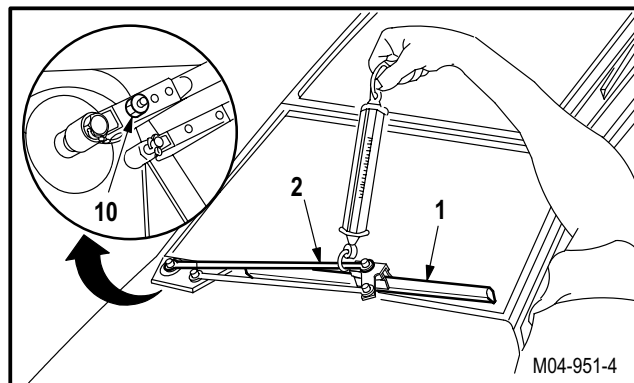

- c. **Inspect (QA).**

- d. **Perform windshield wipers maintenance operational check** (TM 1-1520-238-T).

END OF TASK

## 12.10. CPG WINDSHIELD WIPER ARM REPLACEMENT

### 12.10.1. Description

This task covers: Removal. Cleaning. Inspection. Installation.

### 12.10.2. Initial Setup

#### Tools:

Aircraft mechanic's tool kit (item 376, App H)  
 0.0 - 50.0-pound weighing scale (item 273, App H)

#### References:

TM 1-1520-238-T

#### Materials/Parts:

Wire (item 229, App F)

#### Personnel Required:

67R Attack Helicopter Repairer  
 67R3F Attack Helicopter Repairer/Technical Inspector

#### Equipment Conditions:

Ref	Condition
1.57	Helicopter safed
1.70	External electrical power applied

### 12.10.3. Removal

- a. **Enter pilot station (para 1.56). Observe all safety precautions.**
- b. **On pilot aft circuit breaker panel, close ECS WSHLD WPR circuit breaker.**
- c. **On pilot ANTI-ICE control panel, set WSHLD WIPER switch to PARK, hold, and release.**
- d. **Remove external electrical power (para 1.70).**
- e. **On pilot aft circuit breaker panel, open ECS WSHLD WPR circuit breaker.**
- f. **Remove wiper arm (1) from wiper blade stud (2).**
  - (1) Remove nut (3) and washer (4).
  - (2) Remove arm (1) from stud (2).

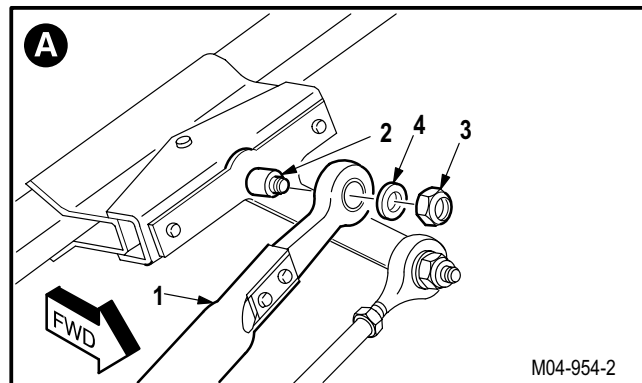
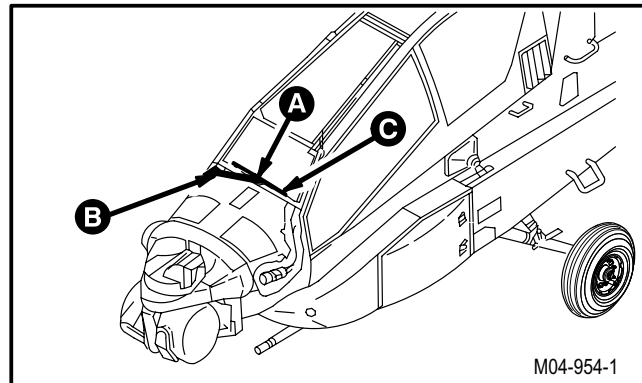

GO TO NEXT PAGE

---

**12.10. CPG WINDSHIELD WIPER ARM REPLACEMENT - continued**



---

**NOTE**

Spacer can fall out when wiper arm is removed.

**g. Remove arm (1) from wiper converter shaft (5).**

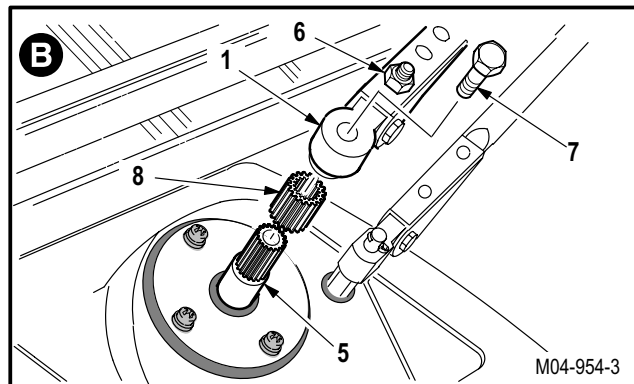
- (1) Loosen nut (6) to release tension on arm (1).
- (2) Remove lockwire from bolt (7).
- (3) Remove bolt (7).
- (4) Remove and discard arm (1) and spacer (8) from shaft (5).



**12.10.4. Cleaning**

- a. **Wipe removed and attaching parts with a clean rag.**

**12.10.5. Inspection**

- a. **Check stud, nut, shaft, and bolts for stripped or damaged threads (para 12.1).**
- b. **Check removed and attaching parts for corrosion (para 1.49).**

**12.10.6. Installation**

- a. **Install new arm (1) on stud (2).**

- (1) Position arm (1) on stud (2).
- (2) Install washer (4) and nut (3).

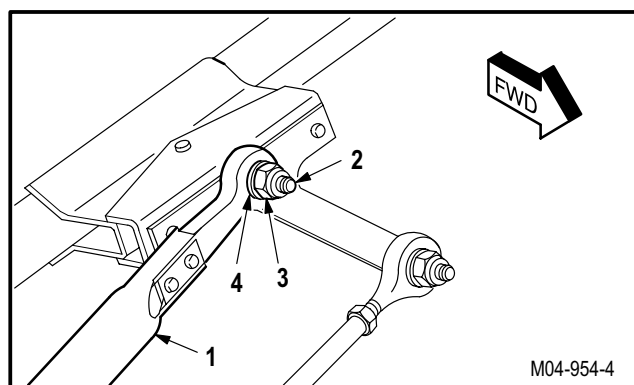

GO TO NEXT PAGE

**12.10. CPG WINDSHIELD WIPER ARM REPLACEMENT - continued**

**NOTE**

To ensure proper installation of wiper, spacer must be installed between wiper arm and converter. Spacer can fall out when wiper arm is removed.

**b. Install arm (1) on shaft (5).**

- (1) Install new spacer (8) and arm (1) on shaft (5).
- (2) Adjust arm (1) on shaft (5) until end of blade (9) is **0.50 INCH** from lower edge of canopy frame (10).

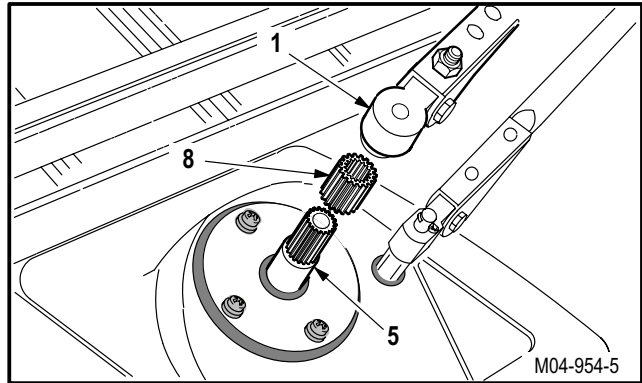

- (3) Install bolt (7) through arm (1) on shaft (5).
- (4) Lockwire bolt (7) to arm (1). Use wire (item 229, App F).

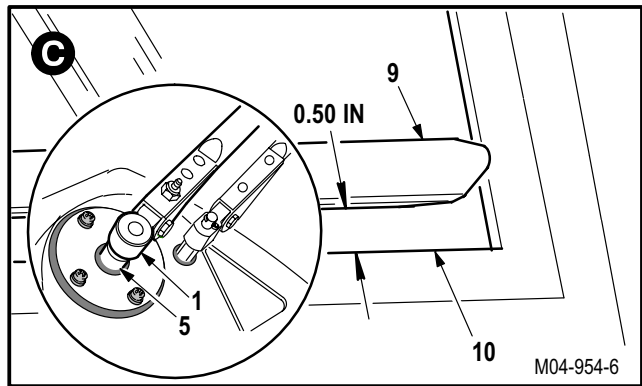

**c. Adjust blade tension to 8 POUNDS.**

- (1) Check tension of blade (9) at end of arm (1). Use scale.
- (2) Adjust tension to **8 POUNDS**.
- (3) Tighten nut (6) to increase tension. Loosen nut (6) to decrease tension.

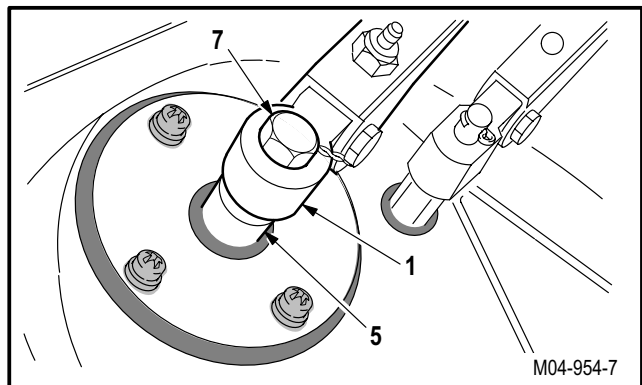

**d. Inspect (QA).**

**e. Perform windshield wipers maintenance operational check (TM 1-1520-238-T).**

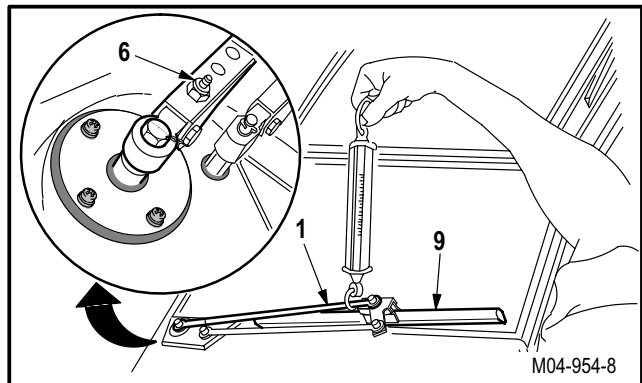

END OF TASK



**12.11. CPG WINDSHIELD WIPER LINK REPLACEMENT**

12.11.1. Description

This task covers: Removal. Cleaning. Inspection. Installation.

12.11.2. Initial Setup

**Tools:**

Aircraft mechanic's tool kit (item 376, App H)

**References:**

TM 1-1520-238-T

**Materials/Parts:**

Cotter pin

**Personnel Required:**

67R Attack Helicopter Repairer  
 67R3F Attack Helicopter Repairer/Technical Inspector

**Equipment Conditions:**

Ref	Condition
1.57	Helicopter safed

12.11.3. Removal

- a. **Enter pilot station** (para 1.56). **Observe all safety precautions.**
- b. **On pilot aft circuit breaker panel, close ECS WSHLD WPR circuit breaker.**
- c. **Remove wiper link (1) from wiper blade stud (2).**
  - (1) Remove nut (3) and washer (4).
  - (2) Remove link (1) from stud (2).

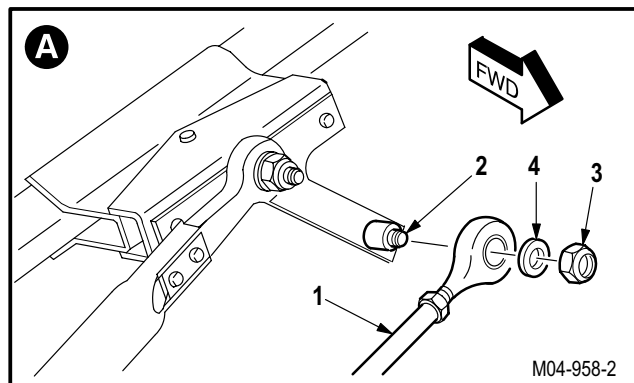
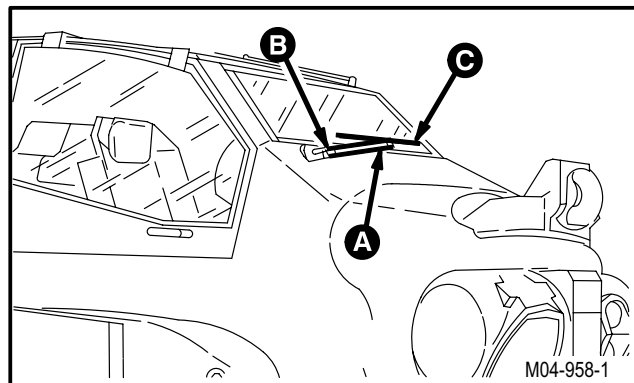

GO TO NEXT PAGE

**12.11. CPG WINDSHIELD WIPER LINK REPLACEMENT - continued**

**d. Remove link (1) from pivot stud (5).**

- (1) Remove and discard cotter pin (6).
- (2) Remove link (1) from stud (5).

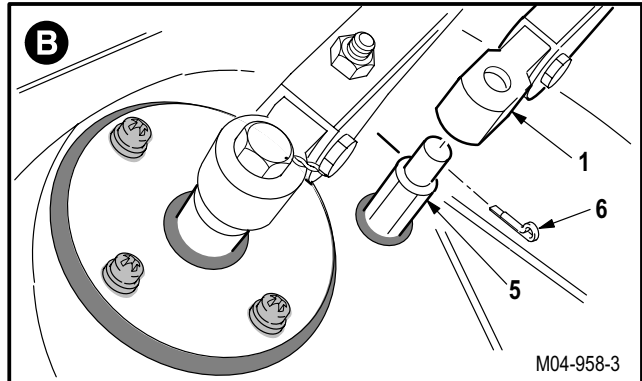

**e. Measure and record distance A from center of rod end (7) to bottom of nut (8).**

**f. Discard link (1).**

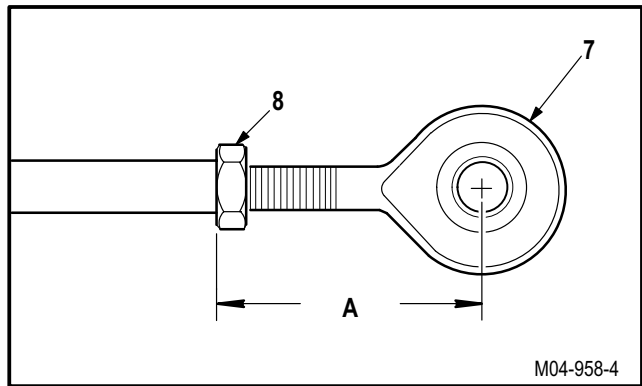

**12.11.4. Cleaning**

- a. Wipe attaching parts with a clean rag.**

**12.11.5. Inspection**

- a. Check studs and nut for stripped or damaged threads (para 12.1).**
- b. Check attaching parts for corrosion (para 1.49).**

**12.11.6. Installation**

- a. Adjust rod end (7) on new link (1) to distance A recorded in paragraph 12.11.3.**

- (1) Loosen nut (8). Adjust rod end (7).
- (2) Hold rod end (7) parallel with mating surface. Tighten nut (8).

GO TO NEXT PAGE

**12.11. CPG WINDSHIELD WIPER LINK REPLACEMENT - continued**

**b. Install link (1) on stud (5).**

- (1) Place link (1) on stud (5).
- (2) Install new cotter pin (6).

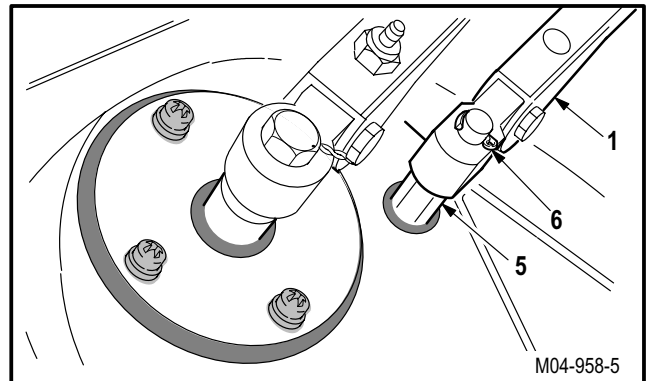

**c. Install link (1) on stud (2).**

- (1) Position link (1) on stud (2).
- (2) Install washer (4) and nut (3).

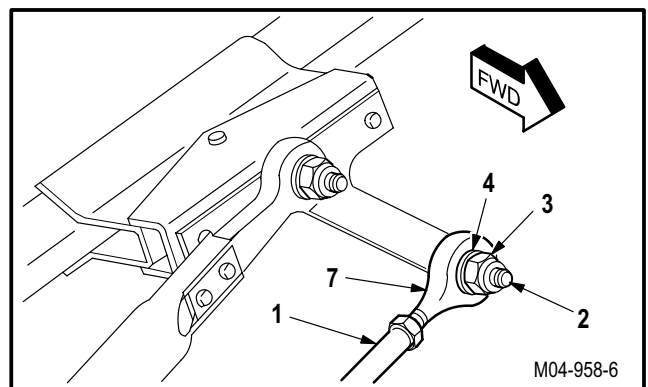

**d. Check for 0.50 INCH clearance between edge of blade (9) and canopy frame (10).**

- (1) Adjust rod end (7) to obtain **0.50 INCH** clearance between left and right edges of blade (9) and canopy frame (10).

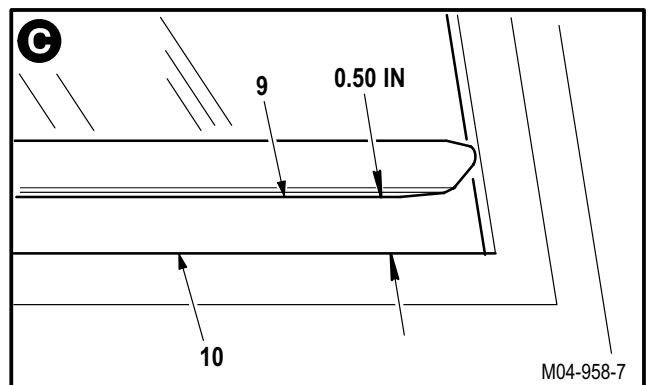

**e. Inspect (QA).**

**f. Perform windshield wipers maintenance operational check (TM 1-1520-238-T).**

END OF TASK

**12.12. CPG WINDSHIELD WIPER CONVERTER REPLACEMENT**

12.12.1. Description

This task covers: Removal. Cleaning. Inspection. Installation.

12.12.2. Initial Setup

**Tools:**

- Aircraft mechanic's tool kit (item 376, App H)
- Light duty laboratory apron (item 27, App H)
- Chemical protective gloves (item 154, App H)
- Adjustable air filtering respirator (item 262, App H)
- 30 - 150 inch-pound 1/4-inch drive click type torque wrench (item 435, App H)

**Materials/Parts:**

- Protective cap
- Brush (item 34, App F)
- Sealing compound (item 175, App F)
- Wire (item 229, App F)

**Personnel Required:**

- 67R Attack Helicopter Repairer
- 67R3F Attack Helicopter Repairer/Technical Inspector

**References:**

- TM 1-1520-238-T
- TM 9-1230-476-20-1

**Equipment Conditions:**

<u>Ref</u>	<u>Condition</u>
1.57	Helicopter safed
2.2	Access panel R40 removed
TM 9-1230-476-20-1	Multiplex remote terminal unit removed
8.32	CPG vertical velocity indicator removed
8.35	CPG remote attitude indicator removed
8.46	CPG clock removed
8.48	CPG stabilator position indicator removed
9.105	CPG caution/warning panel removed
12.10	CPG windshield wiper arm removed
12.11	CPG windshield wiper link removed

12.12.3. Removal

- a. **Enter pilot station (para 1.56). Observe all safety precautions.**
- b. **On pilot aft circuit breaker panel, open ECS WSHLD WPR circuit breaker.**

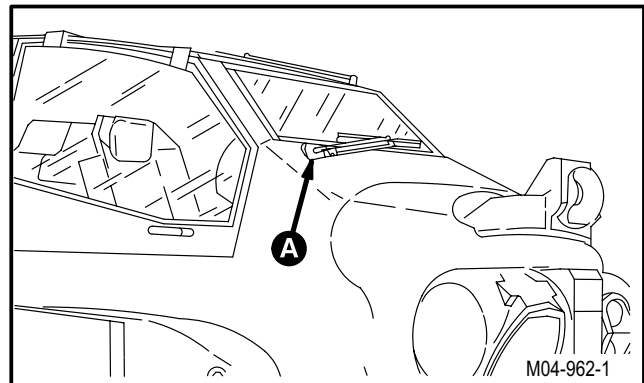

GO TO NEXT PAGE

## 12.12. CPG WINDSHIELD WIPER CONVERTER REPLACEMENT - continued

### c. Remove wiper converter (1) from airframe (2).

- (1) Remove sealing compound from cover (3), converter shaft (4), pivot stud (5), and four screws (6) (para 1.47).
- (2) Remove four screws (6) and washers (7).
- (3) Remove cover (3) from airframe (2).

#### NOTE

The coupling can fall out when flex shaft is removed.

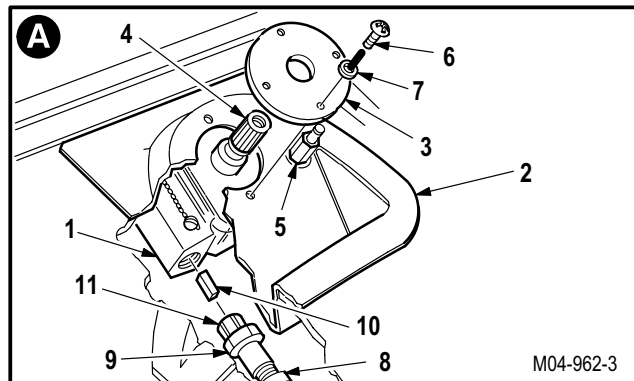

### d. Remove wiper flex shaft (8) from wiper converter (1).

- (1) Remove lockwire from converter (1) and nut (9).
- (2) Remove nut (9) and coupling (10) from converter (1).
- (3) Remove flex shaft (8).
- (4) Install protective cap (11) on nut (9).

### e. Remove adapter (12) from converter (1).

- (1) Hold four screws (13).
- (2) Remove four nuts (14) and washers (15).
- (3) Remove adapter (12) from converter (1).
- (4) Discard converter (1).

#### 12.12.4. Cleaning

- a. **Wipe removed and attaching parts with a clean rag.**
- b. **Clean sealing compound from adapter, cover, and airframe** (para 1.47).

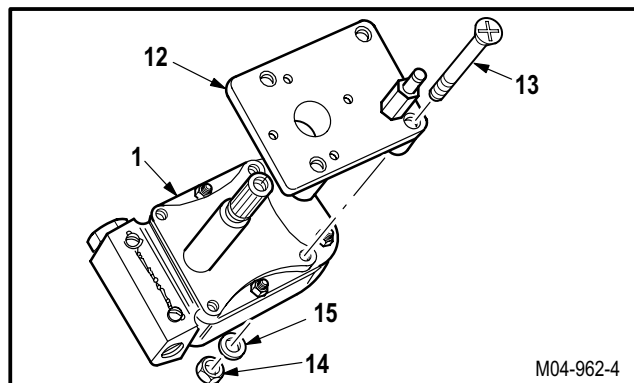

GO TO NEXT PAGE

---

**12.12. CPG WINDSHIELD WIPER CONVERTER REPLACEMENT - continued**

---

12.12.5. Inspection

- a. **Check flex shaft nut for stripped or damaged threads** (para 12.1).
- b. **Check adapter for stripped or damaged threads and nutplates** (para 12.1).
- c. **Check removed and attaching parts for corrosion** (para 1.49).

12.12.6. Installation

a. **Install adapter (12) on new converter (1).**

- (1) Position adapter (12) on converter (1).
- (2) Install and hold four screws (13).
- (3) Install four washers (15) and nuts (14) on screws (13).

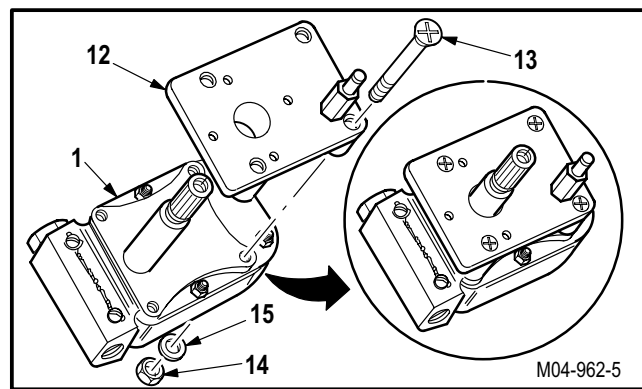

GO TO NEXT PAGE

---

**12.12. CPG WINDSHIELD WIPER CONVERTER REPLACEMENT - continued**



---

**NOTE**

To ensure proper installation of flex shaft, coupling must be installed between flex shaft and converter fitting.

- b. **Install flex shaft (8) on converter (1).** Torque nut (9) to **100 INCH-POUNDS**.

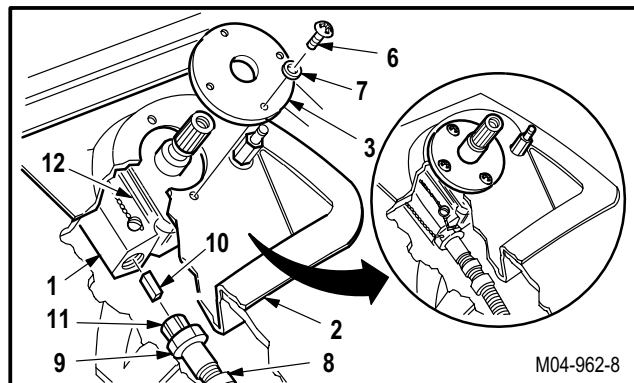
- (1) Remove protective cap (11) from nut (9).
- (2) Install coupling (10) and nut (9) on converter (1).
- (3) Torque nut (9) to **100 INCH-POUNDS**. Use torque wrench.
- (4) Lockwire nut (9) to converter (1). Use wire (item 229, App F).



- c. **Install converter (1) on airframe (2).**

- (1) Position holes on adapter (12) with holes on airframe (2) and cover (3).
- (2) Install four screws (6) through washers (7), cover (3), and airframe (2) into adapter (12).



- d. **Apply sealing compound around cover (3), shaft (4), stud (5), and four screws (6).** Use sealing compound (item 175, App F) and brush (item 34, App F).

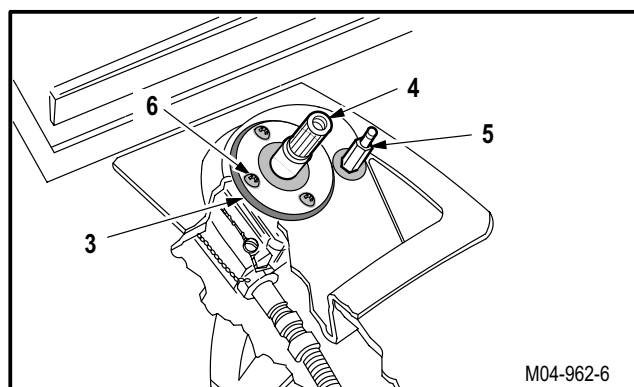

GO TO NEXT PAGE

---

**12.12. CPG WINDSHIELD WIPER CONVERTER REPLACEMENT - continued**

---

- e. **Inspect (QA).**
- f. **Install CPG windshield wiper arm** (para 12.10).
- g. **Install CPG windshield wiper link** (para 12.11).
- h. **Perform windshield wipers maintenance operational check** (TM 1-1520-238-T).
- i. **Install CPG caution/warning panel** (para 9.105).
- j. **Install CPG stabilator position indicator** (para 8.48).
- k. **Install CPG clock** (para 8.46).
- l. **Install CPG remote attitude indicator** (para 8.35).
- m. **Install CPG vertical velocity indicator** (para 8.32).
- n. **Install CPG multiplex remote terminal unit** (TM 9-1230-476-20-1).
- o. **Install access panel R40** (para 2.2).

END OF TASK



**12.13. CPG WINDSHIELD WIPER FLEX SHAFT REPLACEMENT**

12.13.1. Description

This task covers: Removal. Cleaning. Inspection. Installation.

12.13.2. Initial Setup

**Tools:**

Aircraft mechanic's tool kit (item 376, App H)  
 30 - 150 inch-pound 1/4-inch drive click type torque wrench (item 435, App H)

**References:**

TM 1-1520-238-T

**Materials/Parts:**

Wire (item 229, App F)

**Equipment Conditions:**

**Personnel Required:**

67R Attack Helicopter Repairer  
 67R3F Attack Helicopter Repairer/Technical Inspector

<u>Ref</u>	<u>Condition</u>
1.57	Helicopter safed
2.2	Access cover R40 removed
12.12	CPG windshield wiper converter removed

12.13.3. Removal

- a. **Enter pilot station** (para 1.56). **Observe all safety precautions.**
- b. **On pilot aft circuit breaker panel, open ECS WSHLD WPR circuit breaker.**

**NOTE**

- The CPG windshield wiper flex shaft should already be removed from the CPG windshield wiper converter.
- The coupling can fall out when flex shaft is removed.

c. **Remove flex shaft (1) from wiper motor (2).**

- (1) Remove lockwire from motor (2) and nut (3).
- (2) Remove nut (3) and coupling (4) from motor (2).
- (3) Remove and discard flex shaft (1).

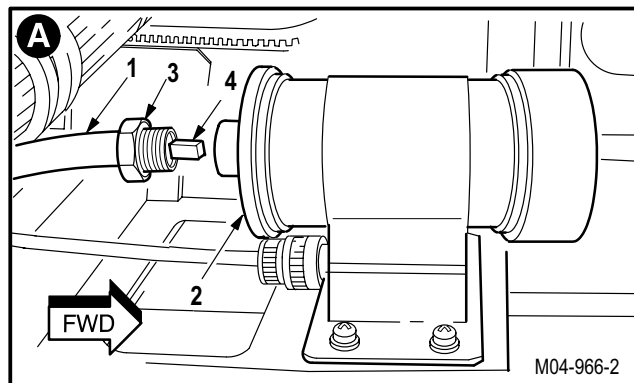
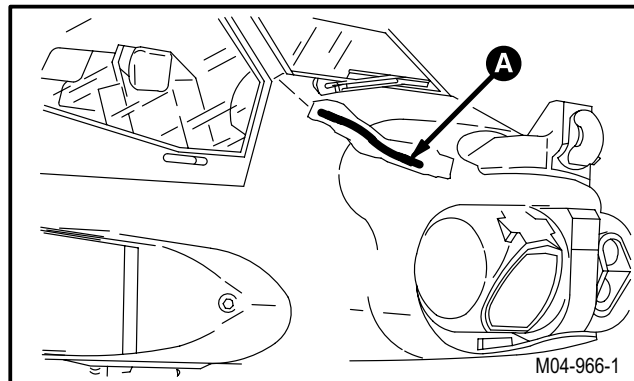

GO TO NEXT PAGE

---

**12.13. CPG WINDSHIELD WIPER FLEX SHAFT REPLACEMENT - continued**

---

12.13.4. Cleaning

- a. **Wipe removed and attaching parts with a clean rag.**

12.13.5. Inspection

- a. **Check motor and converter for stripped or damaged threads** (para 12.1).
- b. **Check removed and attaching parts for corrosion** (para 1.49).

12.13.6. Installation

**NOTE**

To ensure proper installation of flex shaft, coupling must be installed between flex shaft and motor fitting.

- a. **Install new flex shaft (1) on motor (2).** Torque nut (3) to **100 INCH-POUNDS**.

- (1) Install coupling (4) and nut (3) on motor (2).
- (2) Torque nut (3) to **100 INCH-POUNDS**. Use torque wrench.
- (3) Lockwire nut (3) to motor (2). Use wire (item 229, App F).

- b. **Inspect (QA).**
- c. **Install CPG windshield wiper converter** (para 12.12).
- d. **Perform windshield wipers maintenance operational check** (TM 1-1520-238-T).
- e. **Install access cover R40** (para 2.2).

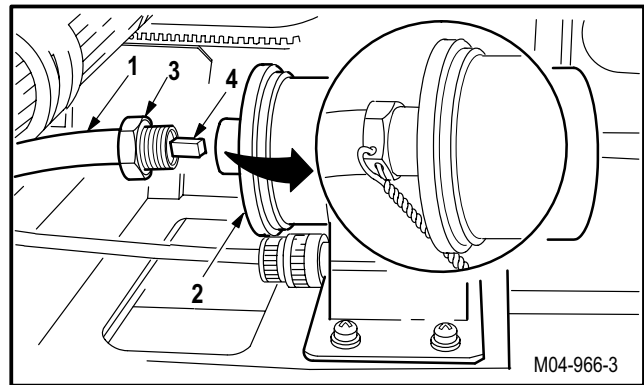

END OF TASK

**12.14. CPG WINDSHIELD WIPER MOTOR REPLACEMENT**

12.14.1. Description

This task covers: Removal. Cleaning. Inspection. Installation.

12.14.2. Initial Setup

**Tools:**

- Aircraft mechanic's tool kit (item 376, App H)
- Light duty laboratory apron (item 27, App H)
- Chemical protective gloves (item 154, App H)
- Adjustable air filtering respirator (item 262, App H)
- 30 - 150 inch-pound 1/4-inch drive click type torque wrench (item 435, App H)

**References:**

- TM 1-1520-238-T
- TM 9-1230-476-20-1

**Materials/Parts:**

- Protective cap
- Brush (item 34, App F)
- Sealing compound (item 175, App F)
- Wire (item 229, App F)

**Equipment Conditions:**

**Personnel Required:**

- 67R Attack Helicopter Repairer
- 67R3F Attack Helicopter Repairer/Technical Inspector

<u>Ref</u>	<u>Condition</u>
1.57	Helicopter safed
2.2	Access panel R40 removed
TM 9-1230-476-20-1	Multiplex remote terminal unit removed

12.14.3. Removal

- a. **Enter pilot station** (para 1.56). **Observe all safety precautions.**
- b. **On pilot aft circuit breaker panel, open ECS WSHLD WPR circuit breaker.**

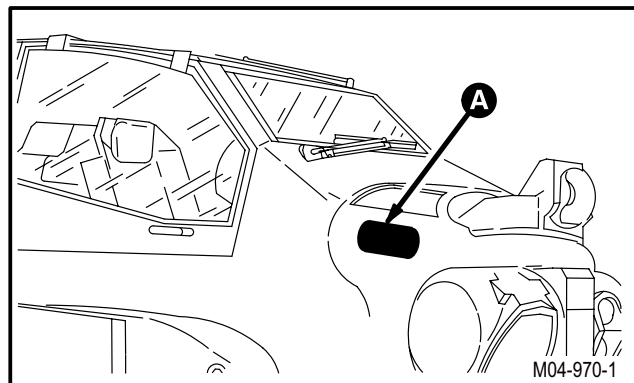

GO TO NEXT PAGE

12.14. CPG WINDSHIELD WIPER MOTOR REPLACEMENT - continued

**NOTE**

The coupling can fall out when flex shaft is removed.

**c. Remove wiper flex shaft (1) from wiper motor (2).**

- (1) Remove lockwire from motor (2) and nut (3).
- (2) Remove nut (3) and coupling (4) from motor (2).
- (3) Install protective cap (5) on nut (3).

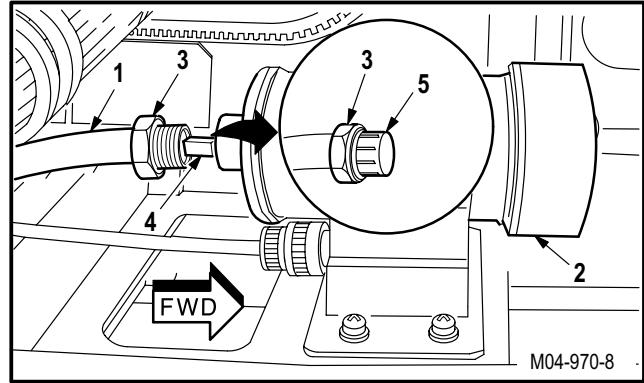

**d. Remove motor (2) and mounting plate (6) from bracket (7).**

- (1) Remove sealant from screw (8), washer (9), and lead (10) (para 1.47).
- (2) Remove screw (8), washer (9), and lead (10).
- (3) Remove three screws (11) and washers (12).
- (4) Remove motor (2) and plate (6).

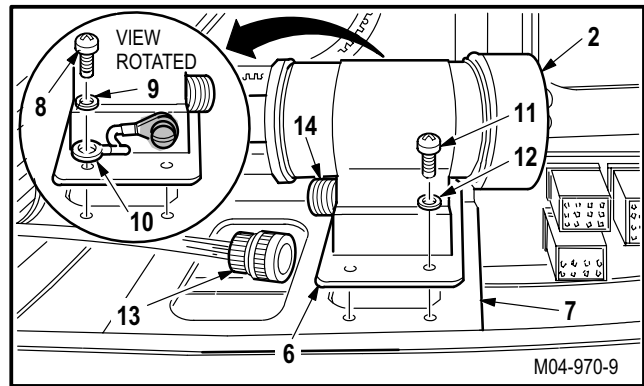

**e. Detach connector P290 (13) from receptacle (B5)J1 (14).**

**f. Remove plate (6) from motor (2).**

- (1) Remove lockwire from four bolts (15).
- (2) Remove four bolts (15) and washers (16) from plate (6).
- (3) Remove plate (6).

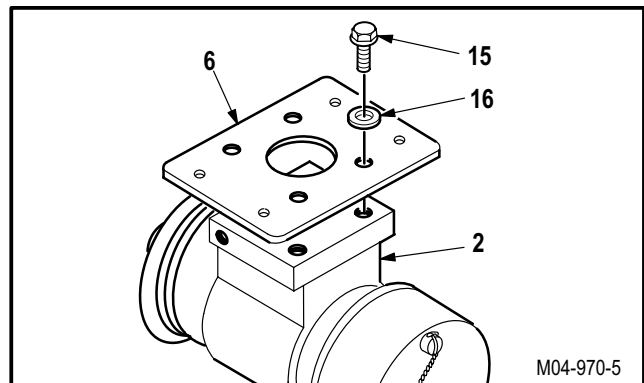

GO TO NEXT PAGE

---

**12.14. CPG WINDSHIELD WIPER MOTOR REPLACEMENT - continued**

---

**12.14.4. Cleaning**

- a. **Wipe removed and attaching parts with a clean rag.**

**12.14.5. Inspection**

- a. **Check flex shaft nut for stripped or damaged threads** (para 12.1).
- b. **Check removed and attaching parts for corrosion** (para 1.49).

**12.14.6. Installation**

- a. **Install plate (6) on new motor (2).**

- (1) Position plate (6) on motor (2).
- (2) Install four bolts (15) and washers (16).
- (3) Lockwire four bolts (15) in pairs. Use wire (item 229, App F).

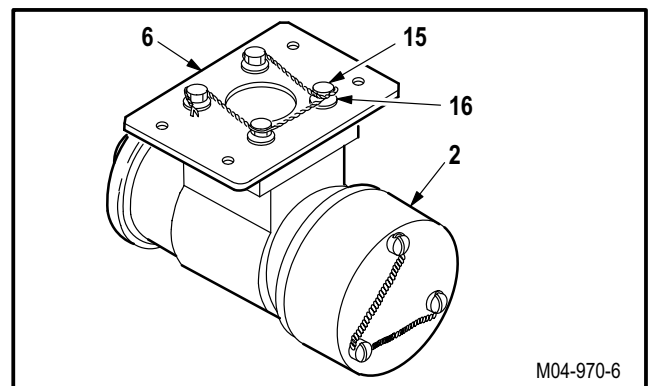

GO TO NEXT PAGE

12.14. CPG WINDSHIELD WIPER MOTOR REPLACEMENT - continued

b. Attach connector P290 (13) to receptacle (B5)J1 (14).

c. Install motor (2) and plate (6) on bracket (7).

- (1) Position plate (6) on bracket (7).
- (2) Install three screws (11) and washers (12) on plate (6).
- (3) Install screw (8), washer (9), and lead (10) on plate (6).



d. Apply sealing compound on screw (8), washer (9), and lead (10). Use sealing compound (item 175, App F) and brush (item 34, App F).

**NOTE**

To ensure proper installation of flex shaft, coupling must be installed between flex shaft and motor fitting.

e. Install flex shaft (1) on motor (2). Torque nut (3) to **100 INCH-POUNDS**.

- (1) Remove protective cap (5) from nut (3).
- (2) Install coupling (4) and nut (3) on motor (2).
- (3) Torque nut (3) to **100 INCH-POUNDS**. Use torque wrench.
- (4) Lockwire nut (3) to motor (2). Use wire (item 229, App F).

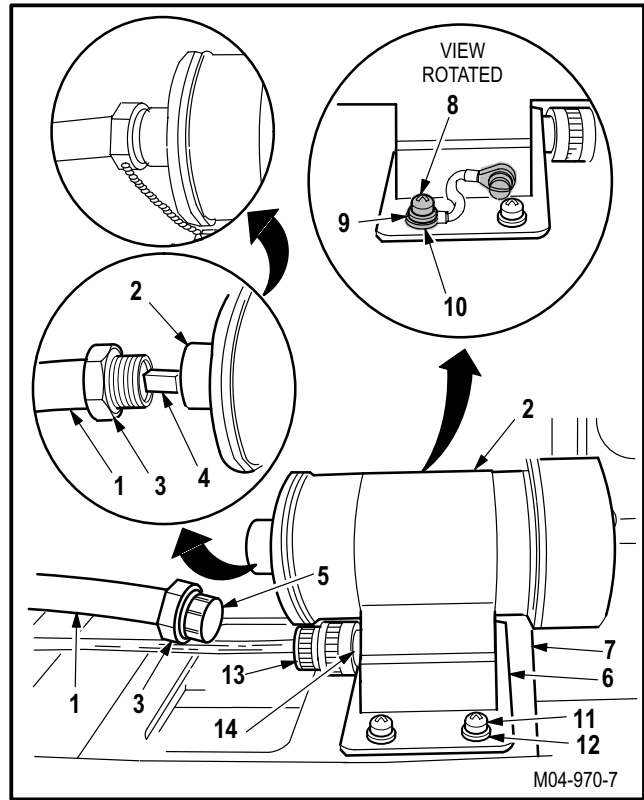

GO TO NEXT PAGE

---

**12.14. CPG WINDSHIELD WIPER MOTOR REPLACEMENT - continued**

---

- f. **Inspect (QA).**
- g. **Verify CPG windshield wiper alignment** (para 12.15).
- h. **Perform windshield wipers maintenance operational check** (TM 1-1520-238-T).
- i. **Install multiplex remote terminal unit** (TM 9-1230-476-20-1).
- j. **Install access cover R40** (para 2.2).

END OF TASK

---

## 12.15. CPG WINDSHIELD WIPER ALINEMENT

---

### 12.15.1. Description

This task covers: Removal. Cleaning. Inspection. Installation.

---

### 12.15.2. Initial Setup

#### Tools:

Aircraft mechanic's tool kit (item 376, App H)  
0.0 - 50.0-pound weighing scale (item 273, App H)

#### Materials/Parts:

Cotter pin  
Wire (item 229, App F)

#### Personnel Required:

67R Attack Helicopter Repairer  
67R3F Attack Helicopter Repairer/Technical  
Inspector

#### References:

TM 1-1520-238-T

#### Equipment Conditions:

<u>Ref</u>	<u>Condition</u>
1.57	Helicopter safed
1.70	External electrical power applied

---

### 12.15.3. Removal

- Enter pilot station (para 1.56). Observe all safety precautions.**
- On pilot aft circuit breaker panel, close ECS WSHLD WPR circuit breaker.**
- On pilot ANTI-ICE control panel, set WSHLD WIPER switch to PARK, hold, and release.**
- Remove external electrical power (para 1.70).**
- On pilot aft circuit breaker panel, open ECS WSHLD WPR circuit breaker.**

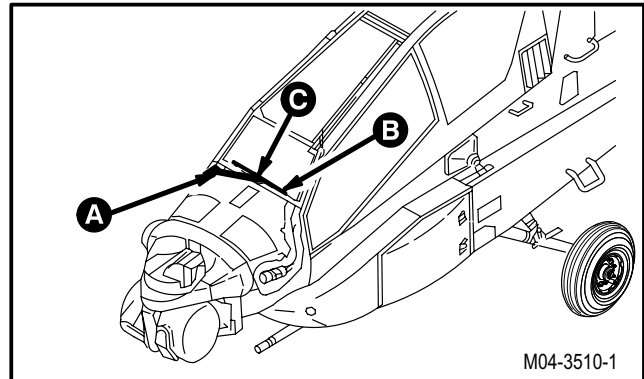

GO TO NEXT PAGE



---

**12.15. CPG WINDSHIELD WIPER ALINEMENT - continued**



---

**NOTE**

Spacer can fall out when wiper arm is removed.

**f. Remove wiper arm (1) from wiper converter shaft (2).**

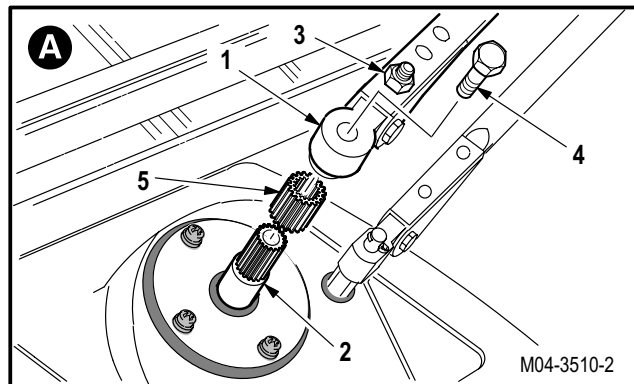
- (1) Loosen nut (3) to release tension on arm (1).
- (2) Remove lockwire from bolt (4).
- (3) Remove bolt (4).
- (4) Remove arm (1) and spacer (5) from shaft (2).



**g. Remove wiper link (6) from pivot stud (7).**

- (1) Remove and discard cotter pin (8).
- (2) Remove link (6) from stud (7).

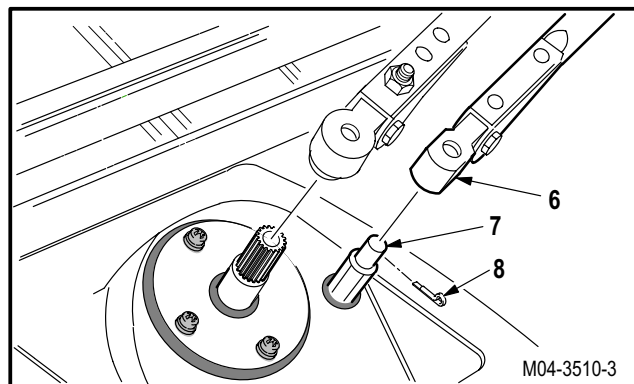

12.15.4. Cleaning

- a. **Wipe removed and attaching parts with a clean rag.**

12.15.5. Inspection

- a. **Check studs, nuts, shaft, and bolts for stripped or damaged threads (para 12.1).**

GO TO NEXT PAGE

**12.15. CPG WINDSHIELD WIPER ALINEMENT - continued**

12.15.6. Installation

**NOTE**

To ensure proper installation of wiper, spacer must be installed between wiper arm and converter. Spacer can fall out when wiper arm is removed.

**a. Install arm (1) on shaft (2).**

- (1) Install spacer (5) and arm (1) on shaft (2).

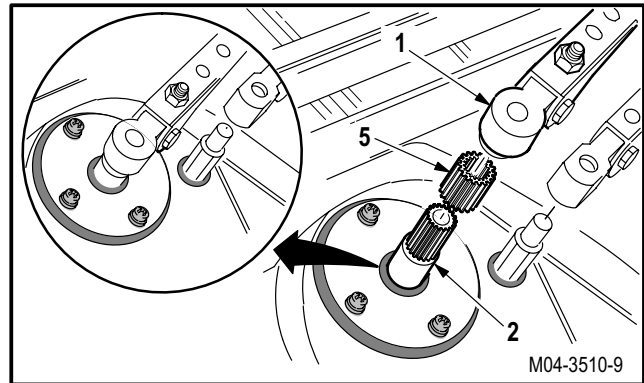

- (2) Adjust arm (1) on shaft (2) until end of blade (9) is **0.50 INCH** from lower edge of canopy frame (10).

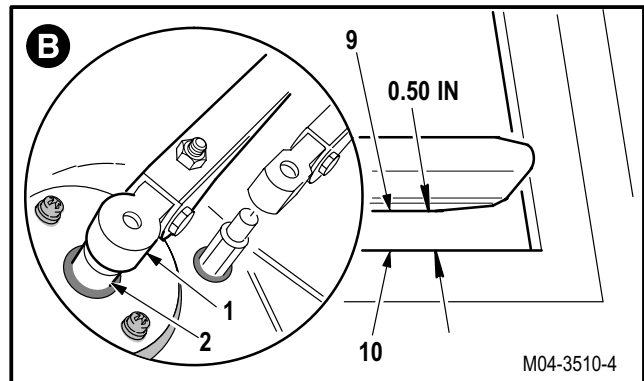

- (3) Install bolt (4) through arm (1) on shaft (2).
- (4) Lockwire bolt (4) to arm (1). Use wire (item 229, App F).

**b. Install link (6) on stud (7).**

- (1) Position link (6) on stud (7).
- (2) Install new cotter pin (8).

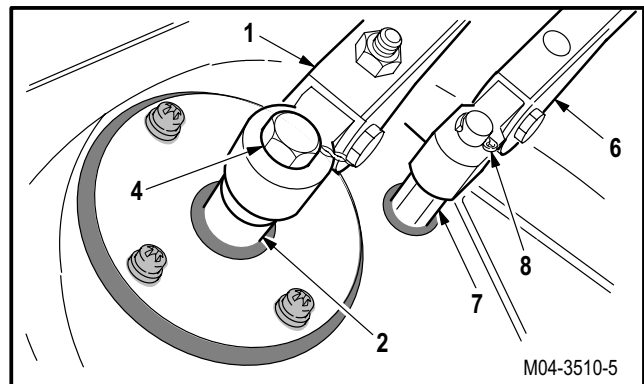

GO TO NEXT PAGE

**12.15. CPG WINDSHIELD WIPER ALINEMENT - continued**

- (3) Check for **0.50 INCH** clearance between edge of blade (9) and canopy frame (10).

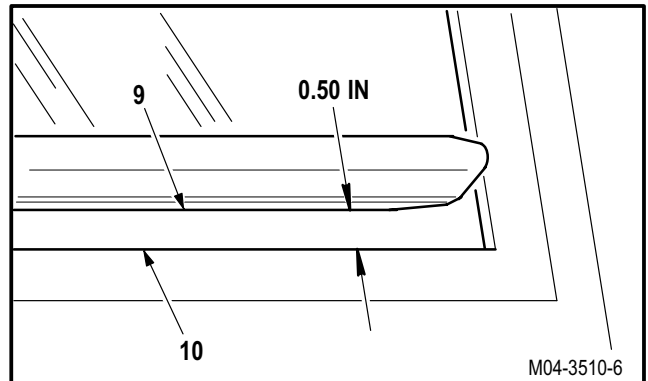

- (4) Adjust rod end (11) to obtain **0.50 INCH** clearance between left and right edges of blade (9) and canopy frame (10).

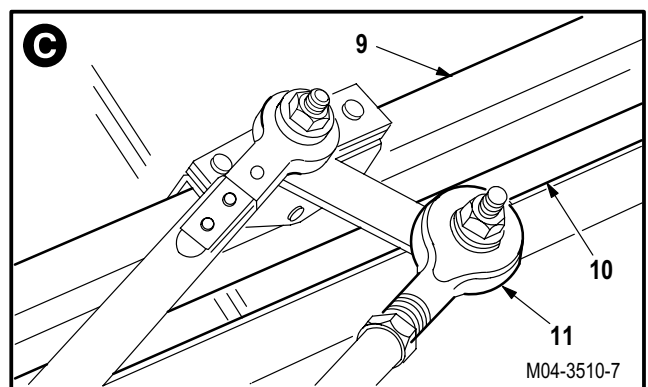

**c. Adjust blade tension to 8 POUNDS.**

- (1) Check tension of blade (9) at end of arm (1). Use scale.
- (2) Adjust tension to **8 POUNDS**.
- (3) Tighten nut (3) to increase tension. Loosen nut (3) to decrease tension.

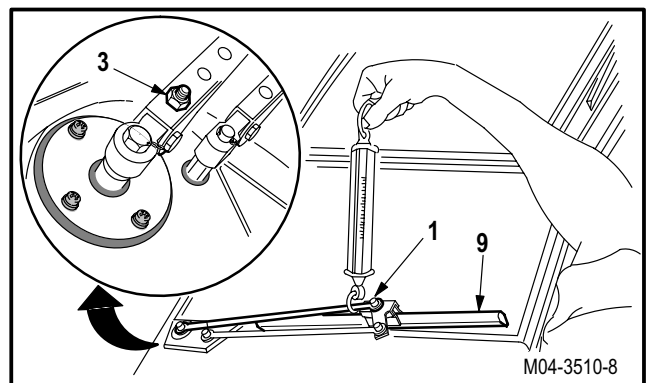

**d. Inspect (QA).**

- e. Perform windshield wipers maintenance operational check (TM 1-1520-238-T).

END OF TASK

## SECTION II. FIRE DETECTION SYSTEM MAINTENANCE

### 12.16. FIRE DETECTION SYSTEM INSPECTION

#### 12.16.1. Description

This task covers: Inspection.

#### 12.16.2. Initial Setup

**Tools:**

Aircraft mechanic's tool kit (item 376, App H)

**References:**

TM 55-1500-323-24

**Personnel Required:**

67R	Attack Helicopter Repairer
67R3F	Attack Helicopter Repairer/Technical Inspector

**Equipment Conditions:**

<u>Ref</u>	<u>Condition</u>
1.57	Helicopter safed

#### 12.16.3. Inspection

- a. **Check flame detectors for missing screws and cracked or broken lenses.** None allowed.
- b. **Check louver fire/overheat detector frames for damaged clips.** None allowed.
- c. **Check flame detector amplifiers for damage or loose screws.** None allowed.
- d. **Check APU fire panel for illegible lettering, cracked or broken lenses, and loose knobs or switches.** None allowed.
- e. **Check connectors for loose or bent pins, thread damage, and for frayed, cut, or loose wires** (TM 55-1500-323-24).
- f. **Check connector operation for smooth positive locking action** (TM 55-1500-323-24).
- g. **Check general mounting hardware for cracks, gouges, nicks, scratches, chafing, damage, rounded flats, and stripped or damaged threads.** Replace damaged hardware.
- h. **Check components for scratches, nicks, and gouges.**
  - (1) Minor scratches without burrs or raised material that does not penetrate through protective finish are acceptable.
  - (2) Nicks and gouges that exceed **0.040 INCH** or 10 percent of material thickness are not allowed.

END OF TASK

**12.17. APU FIRE PANEL ASSEMBLY REMOVAL/INSTALLATION**

12.17.1. Description

This task covers: Removal. Cleaning. Inspection. Installation.

12.17.2. Initial Setup

**Tools:**

Aircraft mechanic's tool kit (item 376, App H)

**References:**

TM 1-1520-238-T

**Personnel Required:**

67R Attack Helicopter Repairer  
 67R3F Attack Helicopter Repairer/Technical Inspector

**Equipment Conditions:**

Ref	Condition
1.57	Helicopter safed

12.17.3. Removal

- a. **Enter pilot station (para 1.56). Observe all safety precautions.**
- b. **On pilot center circuit breaker panel, open FUEL APU, APU HOLD, and FIRE EXTGH APU circuit breakers.**

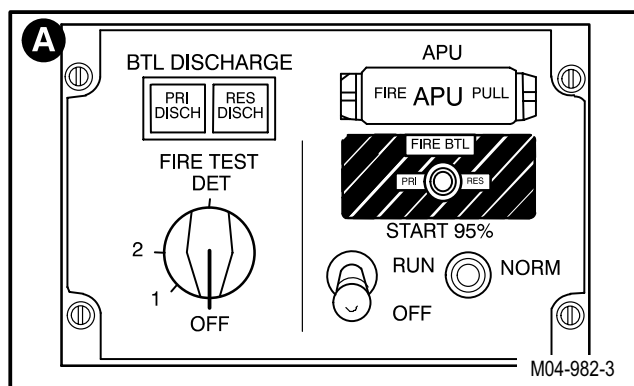
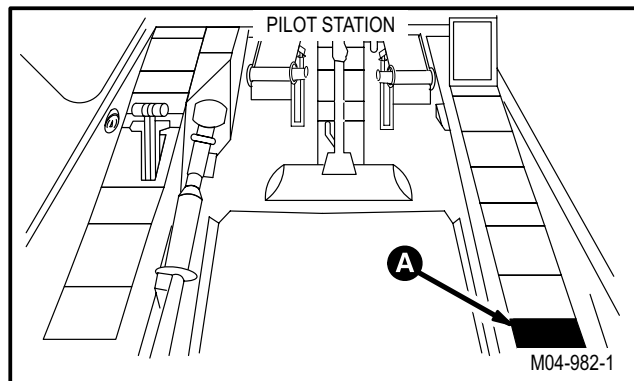

GO TO NEXT PAGE

**12.17. APU FIRE PANEL ASSEMBLY REMOVAL/INSTALLATION - continued**

**c. Remove APU fire panel (1) from console (2).**

- (1) Unlock four turnlock fasteners (3).
- (2) Remove panel (1) from console (2).
- (3) Detach connector P176 (4) from receptacle (A138)J1 (5).

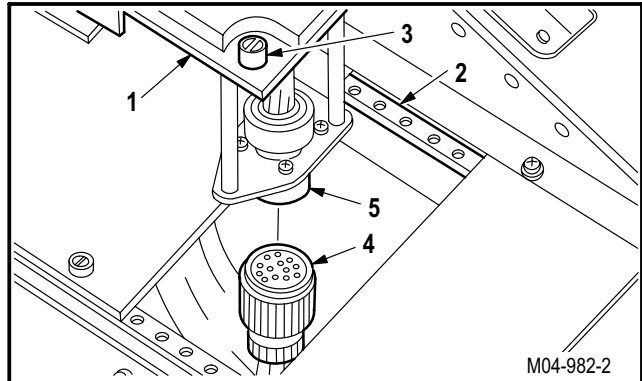

**12.17.4. Cleaning**

- a. **Wipe removed and attaching parts with a clean rag.**

**12.17.5. Inspection**

- a. **Check panel for nicks, dents, or cracks** (para 12.16).
- b. **Check connector for loose or bent pins** (para 12.16).
- c. **Check removed and attaching parts for corrosion** (para 1.49).

**12.17.6. Installation**

**a. Install panel (1) on console (2).**

- (1) Attach connector P176 (4) to receptacle (A138)J1 (5).
- (2) Install panel (1) on console (2).
- (3) Lock four turnlock fasteners (3).

**b. Inspect (QA).**

- c. **Perform fire extinguishers maintenance operational check** (TM 1-1520-238-T).

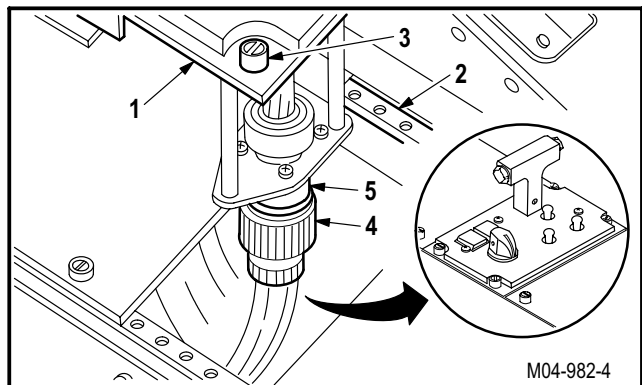

END OF TASK

**12.18. APU FIRE PANEL LIGHT INDICATING PANEL REMOVAL/INSTALLATION**

12.18.1. Description

This task covers: Removal. Cleaning. Inspection. Installation.

12.18.2. Initial Setup

**Tools:**

Electrical tool kit (item 378, App H)

**References:**

TM 1-1520-238-T

**Personnel Required:**

68X Armament/Electrical System Repairer  
 68X3F Armament/Electrical System Repairer/  
 Technical Inspector

**Equipment Conditions:**

<u>Ref</u>	<u>Condition</u>
1.57	Helicopter safed

**NOTE**

This task can be performed on helicopter or off helicopter.

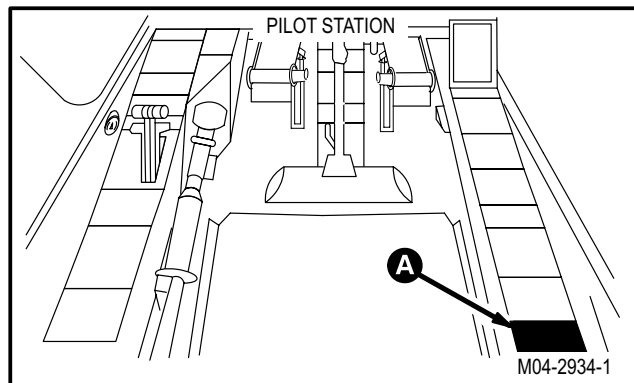

12.18.3. Removal

a. **Remove knob (1) from switch shaft (2).**

- (1) Loosen two screws (3).
- (2) Remove knob (1).

b. **Remove handle (4) from switch shaft (5).**

- (1) Remove screw (6).
- (2) Remove handle (4).

c. **Remove light indicating panel (7) from support panel (8).**

- (1) Remove three screws (9).
- (2) Remove panel (7).

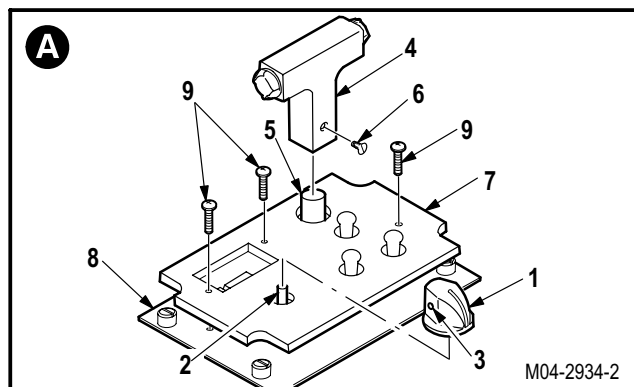

GO TO NEXT PAGE

---

**12.18. APU FIRE PANEL LIGHT INDICATING PANEL REMOVAL/INSTALLATION - continued**

---

12.18.4. Cleaning

- a. **Wipe attaching parts with a clean rag.**

12.18.5. Inspection

- a. **Check support panel for nicks, dents, or cracks** (para 12.16).
- b. **Check attaching parts for corrosion** (para 1.49).

12.18.6. Installation

- a. **Install panel (7) on panel (8).**

- (1) Position panel (7) on panel (8).
- (2) Install three screws (9).

- b. **Install knob (1) on shaft (2).**

- (1) Position knob (1) on shaft (2).
- (2) Tighten two screws (3).

- c. **Install handle (4) on shaft (5).**

- (1) Position handle (4) on shaft (5).
- (2) Install screw (6).

- d. **Inspect (QA).**

- e. **Perform pilot edge-lights maintenance operational check** (TM 1-1520-238-T).

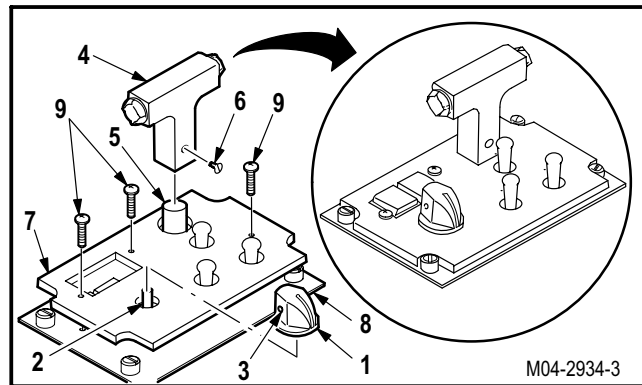

END OF TASK



**12.19. APU FIRE PANEL SWITCH REPLACEMENT (AVIM)**

12.19.1. Description

This task covers: Removal. Cleaning. Inspection. Installation.

12.19.2. Initial Setup

**Tools:**

- Electrical tool kit (item 378, App H)
- Light duty laboratory apron (item 27, App H)
- Chemical protective gloves (item 154, App H)
- Adjustable air filtering respirator (item 262, App H)
- Soldering gun (item 334, App H)

**Personnel Required:**

- 68X Armament/Electrical System Repairer
- 68X3F Armament/Electrical System Repairer/  
Technical Inspector

**References:**

TM 55-1500-323-24

**Equipment Conditions:**

<u>Ref</u>	<u>Condition</u>
12.18	APU fire panel light indicating panel removed

**Materials/Parts:**

Solder (item 189, App F)

**NOTE**

This task is typical for switches on the APU fire panel. Switches differ in number and placement of wires and jumpers.

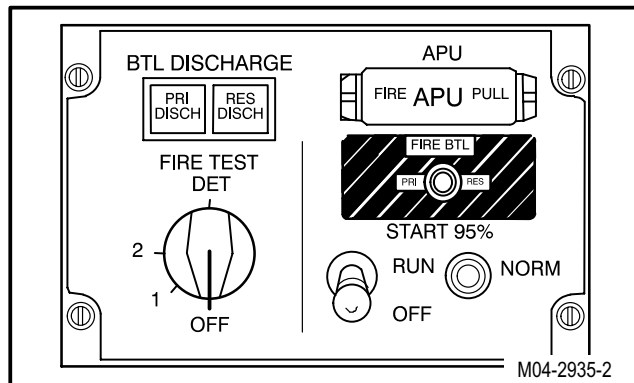

GO TO NEXT PAGE

12.19. APU FIRE PANEL SWITCH REPLACEMENT (AVIM) - continued

12.19.3. Removal



**WARNING**

Soldering gun can cause severe burns to personnel and start fires. Observe all safety precautions when using soldering gun. If injury occurs, seek medical aid.

a. Desolder wires (1) from fire pull switch (2).

- (1) Identify and desolder wires (1) from terminals (3). Use soldering gun (TM 55-1500-323-24).

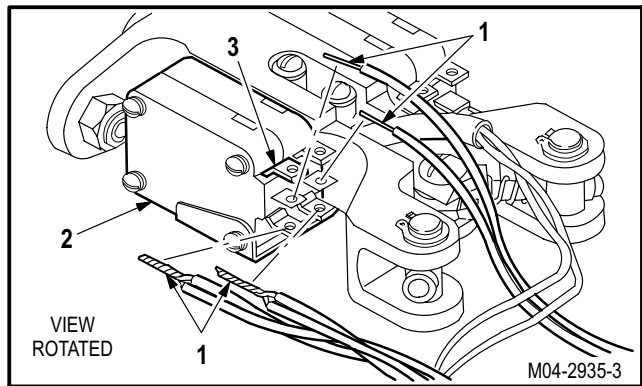

b. Identify and depin two wires (4) and (5) from receptacle (A138)J1 (6) (TM 55-1500-323-24).

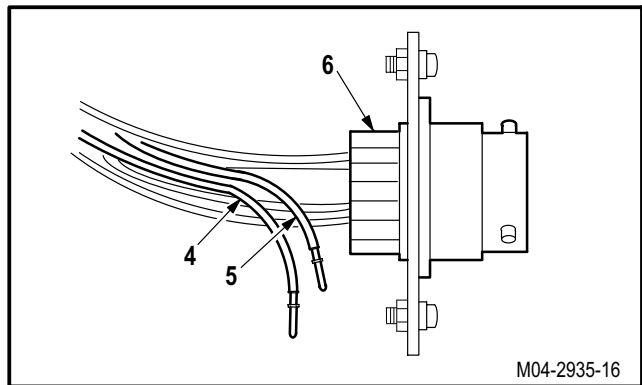

c. Remove switch (2) from support panel (7).

- (1) Remove two screws (8).
- (2) Remove and discard switch (2).

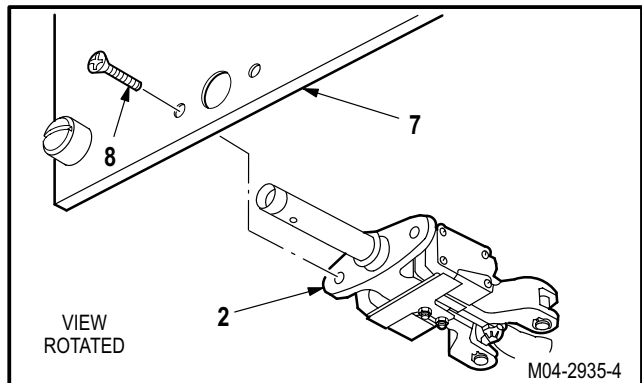

GO TO NEXT PAGE

**12.19. APU FIRE PANEL SWITCH REPLACEMENT (AVIM) - continued**

**d. Desolder wires (9) from rotary switch (10).**

- (1) Identify and desolder wires (9) from terminals (11). Use soldering gun (TM 55-1500-323-24).

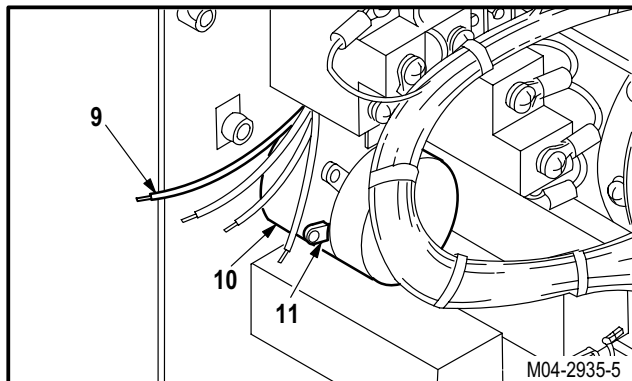

**e. Remove switch (10) from panel (7).**

- (1) Remove nut (12) and lockwasher (13) from switch (10).
- (2) Remove switch (10) and lockring (14) from panel (7).
- (3) Discard switch (10).

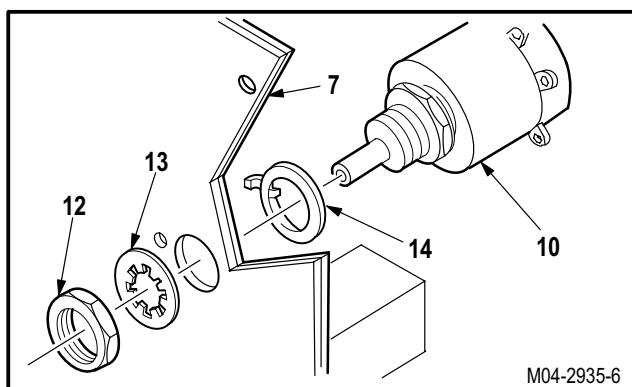

**f. Detach wires (15) and jumpers (16) from toggle switch (17).**

- (1) Identify wires (15) and jumpers (16).
- (2) Remove screws (18) and lockwashers (19).
- (3) Remove wires (15) and jumpers (16).

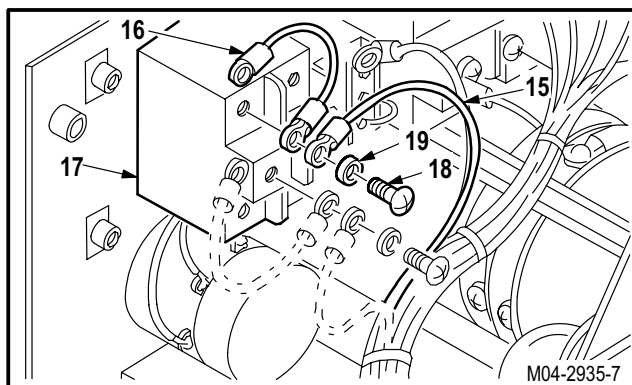

**g. Remove switch (17) from panel (7).**

- (1) Remove nut (20) and lockwasher (21) from switch (17).
- (2) Remove switch (17) and lockring (22) from panel (7).
- (3) Discard switch (17).

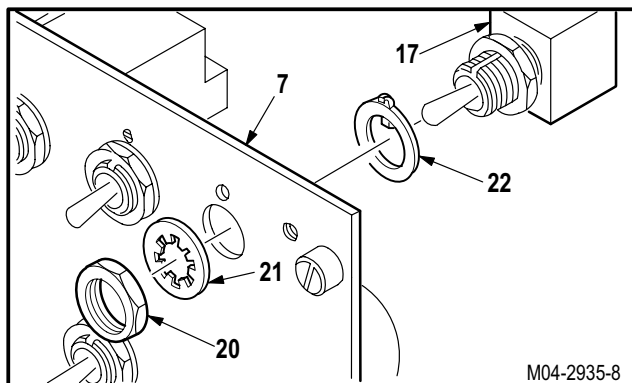

GO TO NEXT PAGE

---

**12.19. APU FIRE PANEL SWITCH REPLACEMENT (AVIM) - continued**

---

12.19.4. Cleaning

- a. **Wipe removed and attaching parts with a clean rag.**

12.19.5. Inspection

- a. **Check panel for nicks, dents, or cracks** (para 12.16).
- b. **Check switches for loose terminals, cracks, and signs of overheating** (para 12.16).
- c. **Check removed and attaching parts for corrosion** (para 1.49).

12.19.6. Installation

- a. **Remove handle from new switch (2)** (para 12.18).
- b. **Install switch (2) on panel (7).**
  - (1) Position switch (2) on panel (7).
  - (2) Install two screws (8).

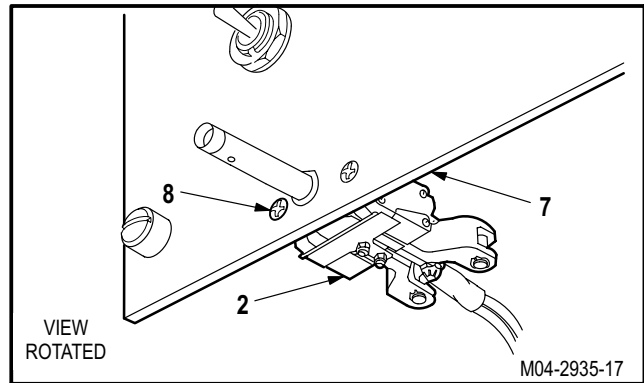

GO TO NEXT PAGE

12.19. APU FIRE PANEL SWITCH REPLACEMENT (AVIM) - continued



**WARNING**

Soldering gun can cause severe burns to personnel and start fires. Observe all safety precautions when using soldering gun. If injury occurs, seek medical aid.

c. Solder wires (1) to switch (2).

- (1) Solder identified wires (1) to terminals (3). Use soldering gun and solder (item 189, App F) (TM 55-1500-323-24).

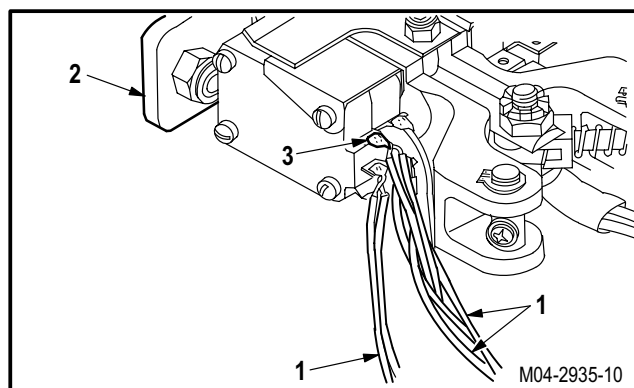

d. Pin two identified wires (4) and (5) in receptacle (A138)J1 (6) (TM 55-1500-323-24).

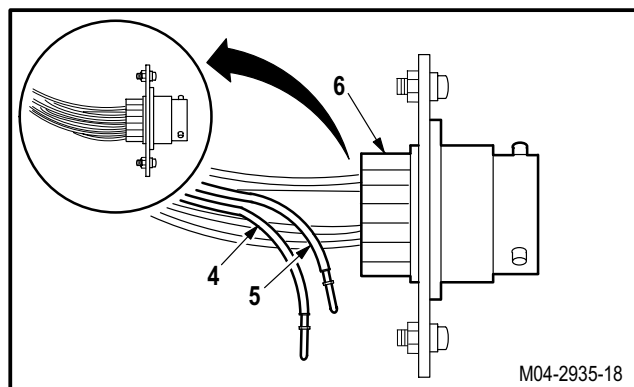

GO TO NEXT PAGE

**12.19. APU FIRE PANEL SWITCH REPLACEMENT (AVIM) - continued**

**e. Install new switch (10) on panel (7).**

- (1) Install switch (10) so tab (23) on lockring (14) seats in alignment hole (24) on panel (7).
- (2) Install lockwasher (13) and nut (12) on switch (10).

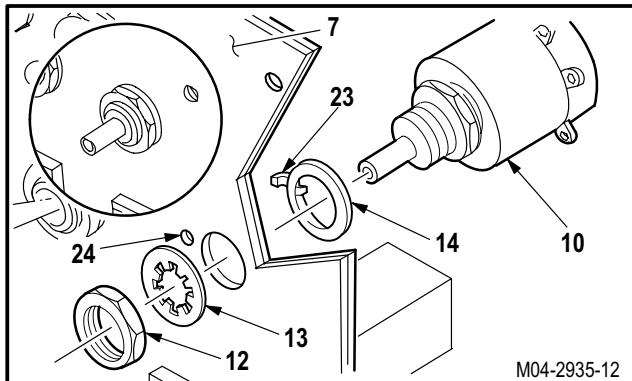

**f. Solder wires (9) to switch (10).**

- (1) Solder identified wires (9) to terminals (11). Use soldering gun and solder (item 189, App F) (TM 55-1500-323-24).

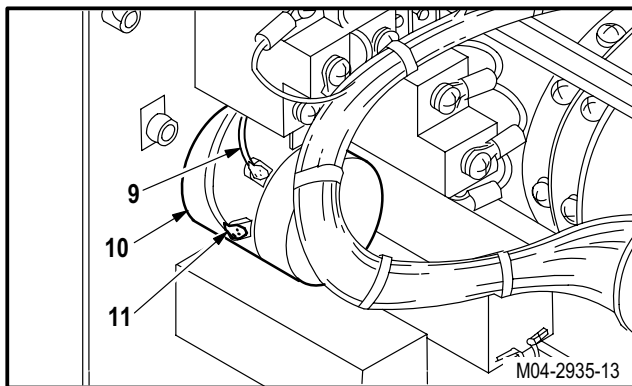

**g. Install new switch (17) on panel (7).**

- (1) Install switch (17) so tab (25) on lockring (22) seats in alignment hole (26) on panel (7).
- (2) Install lockwasher (21) and nut (20) on switch (17).

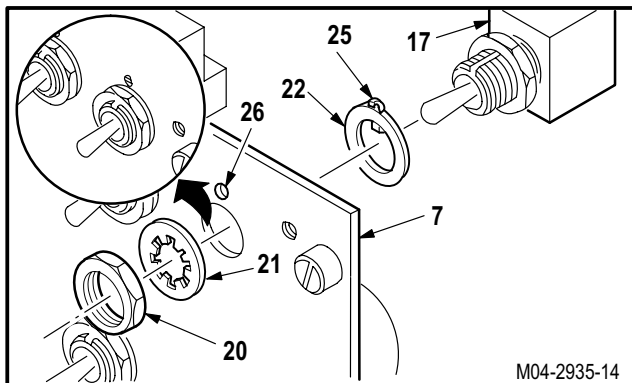

**h. Attach wires (15) and jumpers (16) on switch (17).**

- (1) Position identified wires (15) and jumpers (16) on switch (17).
- (2) Install screws (18) and lockwashers (19).

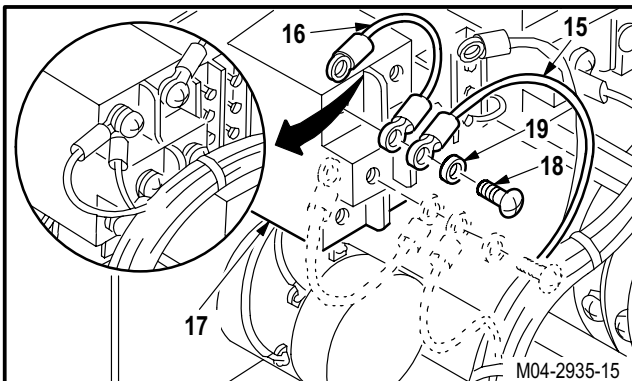

**i. Inspect (QA).**

**j. Install APU fire panel light indicating panel (para 12.18).**

END OF TASK

**12.20. APU FIRE PANEL INDICATOR REPLACEMENT (AVIM)**

12.20.1. Description

This task covers: Removal. Cleaning. Inspection. Installation.

12.20.2. Initial Setup

**Tools:**

- Electrical tool kit (item 378, App H)
- Light duty laboratory apron (item 27, App H)
- Chemical protective gloves (item 154, App H)
- Adjustable air filtering respirator (item 262, App H)
- Soldering gun (item 334, App H)

**Personnel Required:**

- 68X Armament/Electrical System Repairer
- 68X3F Armament/Electrical System Repairer/  
Technical Inspector

**References:**

TM 55-1500-323-24

**Equipment Conditions:**

<u>Ref</u>	<u>Condition</u>
12.18	APU fire panel light indicating panel removed

**Materials/Parts:**

Solder (item 189, App F)

**NOTE**

This task is typical for either indicator.

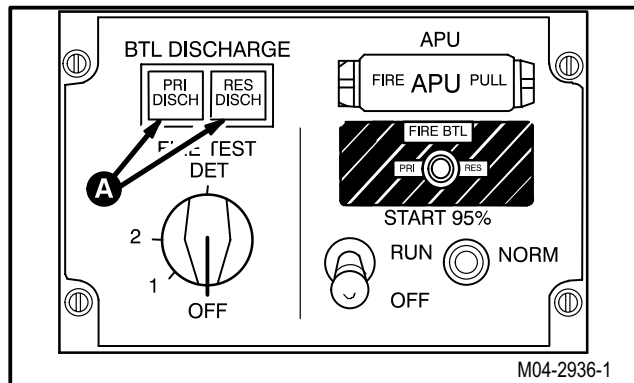

GO TO NEXT PAGE

12.20. APU FIRE PANEL INDICATOR REPLACEMENT (AVIM) - continued

12.20.3. Removal



**WARNING**

**Soldering gun can cause severe burns to personnel and start fires. Observe all safety precautions when using soldering gun. If injury occurs, seek medical aid.**

a. **Desolder wires (1) from indicator (2).**

- (1) Identify and desolder wires (1) from terminals (3). Use soldering gun (TM 55-1500-323-24).

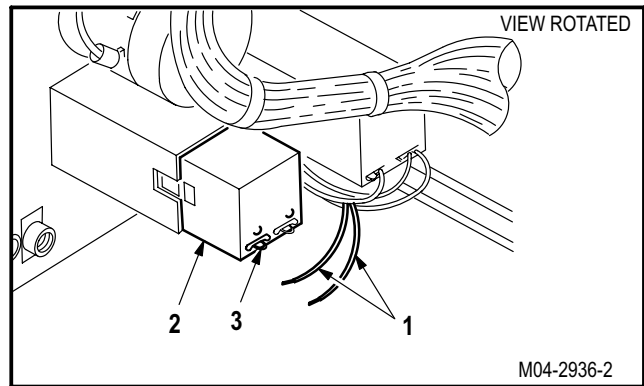

b. **Remove indicator (2) from panel (4).**

- (1) Remove and move lens (5) to one side.
- (2) Loosen two screws (6).

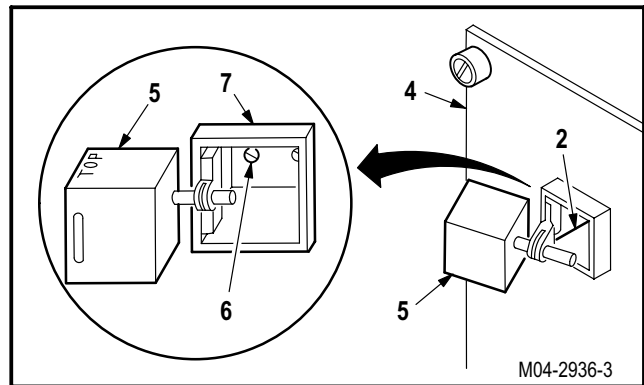

- (3) Hold spacer (7). Remove sleeve (8) from indicator (2).
- (4) Remove and discard indicator (2) from panel (4).

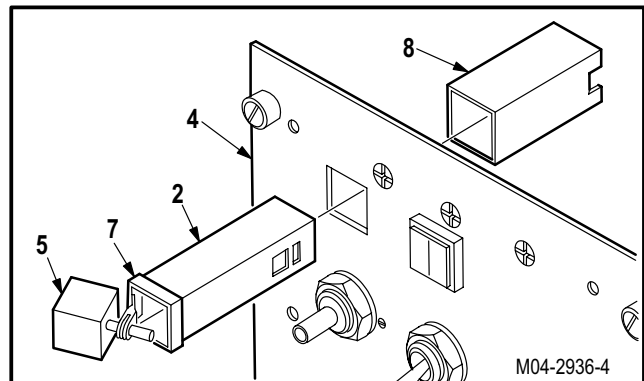

GO TO NEXT PAGE



---

**12.20. APU FIRE PANEL INDICATOR REPLACEMENT (AVIM) - continued**

---

**12.20.4. Cleaning**

- a. **Wipe attaching parts with a clean rag.**

**12.20.5. Inspection**

- a. **Check panel for nicks, dents, or cracks** (para 12.16).
- b. **Check switches for loose terminals, cracks, and signs of overheating** (para 12.16).
- c. **Check attaching parts for corrosion** (para 1.49).

**12.20.6. Installation**

- a. **Install new indicator (2) on panel (4).**

- (1) Install spacer (7) on indicator (2).
- (2) Install indicator (2) through opening in panel (4).
- (3) Install sleeve (8) on indicator (2).
- (4) Tighten two screws (6).
- (5) Install lens (5).

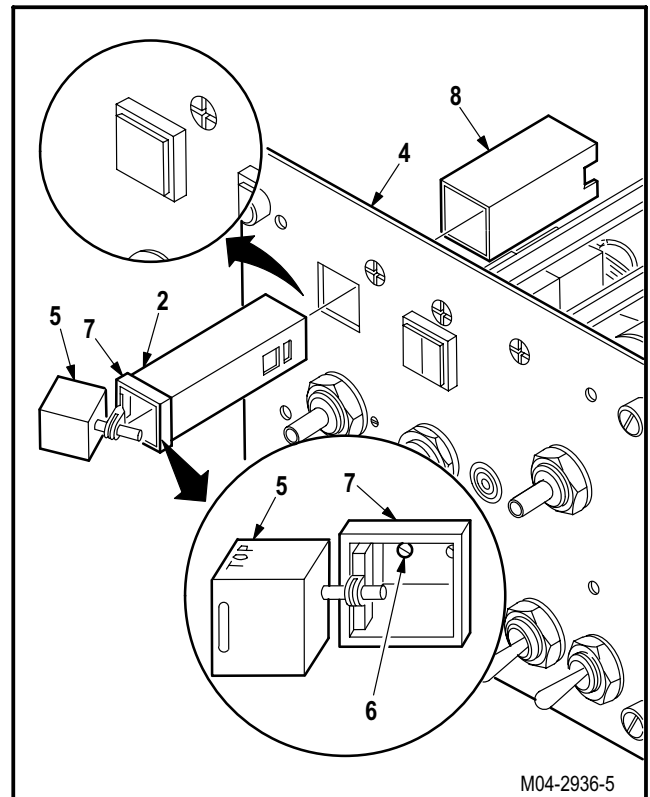

GO TO NEXT PAGE

---

12.20. APU FIRE PANEL INDICATOR REPLACEMENT (AVIM) - continued

---



**WARNING**

**Soldering gun can cause severe burns to personnel and start fires. Observe all safety precautions when using soldering gun. If injury occurs, seek medical aid.**

**b. Solder wires (1) to indicator (2).**

(1) Solder identified wires (1) to terminals (3). Use soldering gun and solder (item 189, App F) (TM 55-1500-323-24).

**c. Inspect (QA).**

**d. Install APU fire panel light indicating panel (para 12.18).**

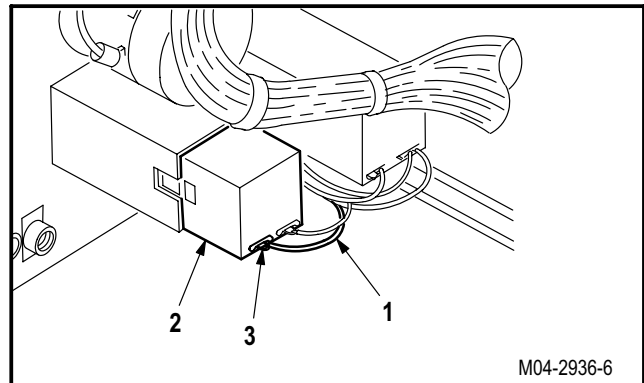

END OF TASK

**12.21. APU FIRE PANEL LIGHT INDICATING PANEL RECEPTACLE REPLACEMENT (AVIM)**

12.21.1. Description

This task covers: Removal. Cleaning. Inspection. Installation.

12.21.2. Initial Setup

**Tools:**

Electrical tool kit (item 378, App H)

**Personnel Required:**

68X Armament/Electrical System Repairer  
 68X3F Armament/Electrical System Repairer/  
 Technical Inspector

**Equipment Conditions:**

<u>Ref</u>	<u>Condition</u>
12.18	APU fire panel light indicating panel removed

12.21.3. Removal

a. **Detach wire (1) from terminal (2).**

- (1) Remove screw (3), lockwasher (4), and terminal lug (5).
- (2) Remove wire (1).

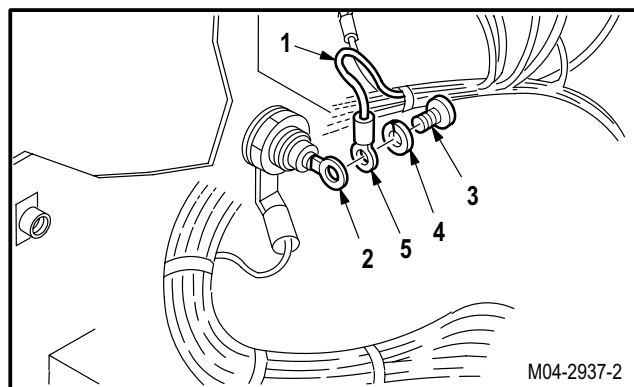
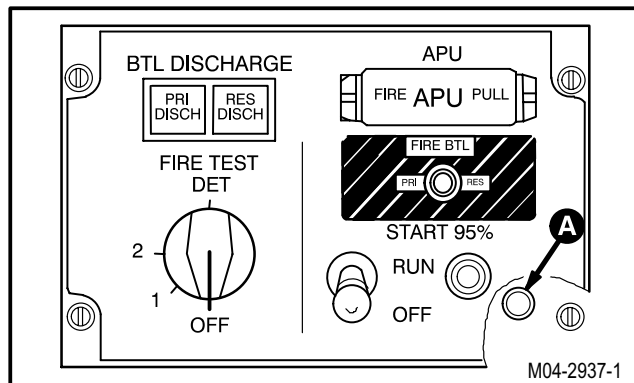

GO TO NEXT PAGE

**12.21. APU FIRE PANEL LIGHT INDICATING PANEL RECEPTACLE REPLACEMENT (AVIM) - continued**

**b. Remove receptacle (6) from support panel (7).**

- (1) Remove nut (8), washer (9), and terminal lug (10).
- (2) Remove receptacle (6) from panel (7).

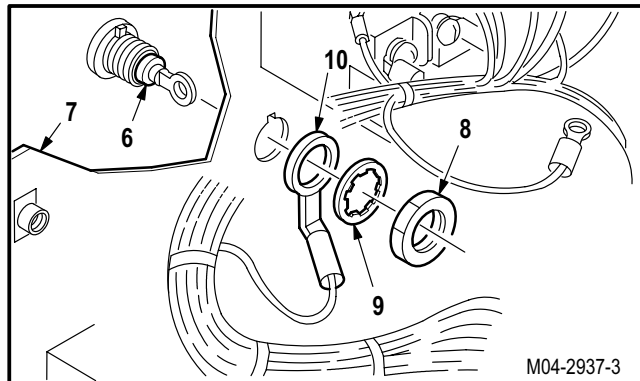

**12.21.4. Cleaning**

**a. Wipe removed and attaching parts with a clean rag.**

**12.21.5. Inspection**

- a. **Check for loose or frayed wires on terminal lugs** (para 12.16).
- b. **Check panel for nicks, dents, or cracks** (para 12.16).
- c. **Check switches for loose terminals, cracks, and signs of overheating** (para 12.16).
- d. **Check removed and attaching parts for corrosion** (para 1.49).

**12.21.6. Installation**

**a. Install receptacle (6) on panel (7).**

- (1) Install receptacle (6) through opening in front of panel (7) so tab (11) aligns with notch (12).
- (2) Install terminal lug (10), washer (9), and nut (8).

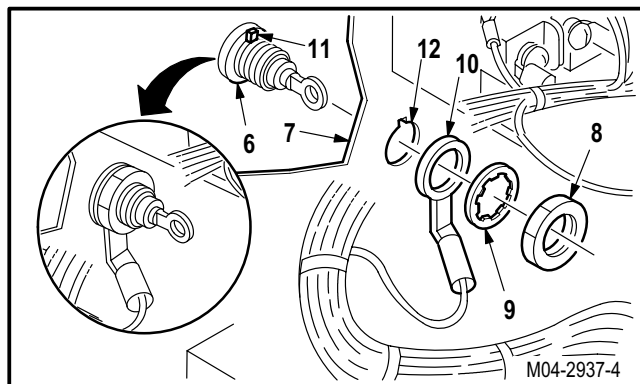

**b. Attach wire (1) to terminal (2).**

- (1) Position terminal lug (5) on terminal (2).
- (2) Install screw (3) and lockwasher (4).

**c. Inspect (QA).**

**d. Install APU fire panel light indicating panel** (para 12.18).

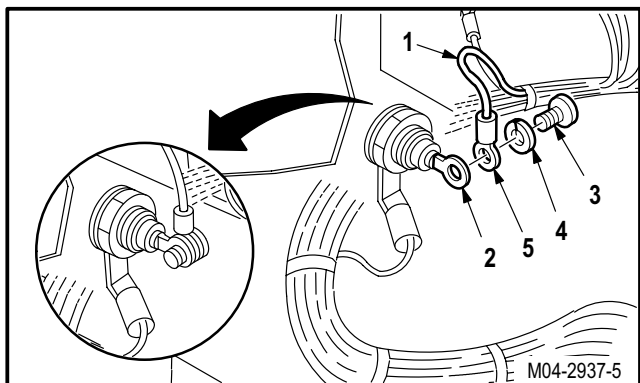

END OF TASK

---

## 12.22. APU FIRE PANEL CIRCUIT CARD REPLACEMENT (AVIM)

---

### 12.22.1. Description

This task covers: Removal. Cleaning. Inspection. Installation.

---

### 12.22.2. Initial Setup

#### **Tools:**

Electrical tool kit (item 378, App H)  
 Light duty laboratory apron (item 27, App H)  
 Chemical protective gloves (item 154, App H)  
 Adjustable air filtering respirator (item 262, App H)  
 5-watt electric soldering iron (item 333, App H)

#### **Materials/Parts:**

Solder (item 189, App F)

#### **Personnel Required:**

68X Armament/Electrical System Repairer  
 68X3F Armament/Electrical System Repairer/  
 Technical Inspector

#### **References:**

TM 55-1500-323-24

#### **Equipment Conditions:**

<u>Ref</u>	<u>Condition</u>
12.18	APU fire panel light indicating panel removed

---

GO TO NEXT PAGE

**12.22. APU FIRE PANEL CIRCUIT CARD REPLACEMENT (AVIM) - continued**

12.22.3. Removal

**a. Remove connector (1) from circuit card (2).**

- (1) Remove four screws (3), washers (4), and nuts (5).
- (2) Remove connector (1).

**b. Remove switch (6) from circuit card (2) and panel (7).**

- (1) Remove nut (8) from switch (6).
- (2) Remove switch (6), lockring (9), and washer (10).

**c. Remove post (11) from circuit card (2) and panel (7).**

- (1) Remove screw (12) and washer (13).
- (2) Remove screw (14) and post (11).



**WARNING**

**Soldering iron can cause severe burns to personnel and start fires. Observe all safety precautions when using soldering iron. If injury occurs, seek medical aid.**

**d. Identify and desolder wires (15) from circuit card (2). Use soldering iron (TM 55-1500-323-24).**

**e. Remove circuit card (2) from panel (7).**

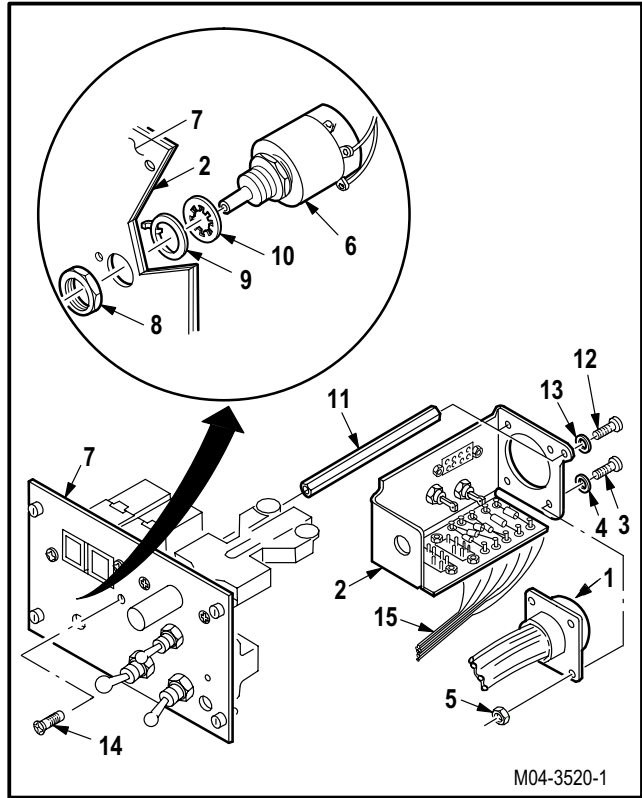

M04-3520-1

12.22.4. Cleaning

**a. Wipe removed and attaching parts with a clean rag.**

GO TO NEXT PAGE

## 12.22. APU FIRE PANEL CIRCUIT CARD REPLACEMENT (AVIM) - continued

### 12.22.5. Inspection

- a. **Check panel for nicks, dents, or cracks** (para 12.16).
- b. **Check wires for cuts, nicks, fraying, or chafing** (para 12.16).
- c. **Check switches for loose terminals, cracks, and signs of overheating** (para 12.16).
- d. **Check removed and attaching parts for corrosion** (para 1.49).

### 12.22.6. Installation



#### WARNING

**Soldering iron can cause severe burns to personnel and start fires. Observe all safety precautions when using soldering iron. If injury occurs, seek medical aid.**

- a. **Solder identified wires (15) to new circuit card (2).** Use soldering iron and solder (item 189, App F) (TM 55-1500-323-24).
- b. **Install post (11) on circuit card (2) and panel (7).**
  - (1) Position circuit card (2) on panel (7).
  - (2) Install screw (14) through panel (7) into post (11).
  - (3) Install screw (12) and washer (13).
- c. **Install connector (1) on circuit card (2).**
  - (1) Install four screws (3), washers (4), and nuts (5).

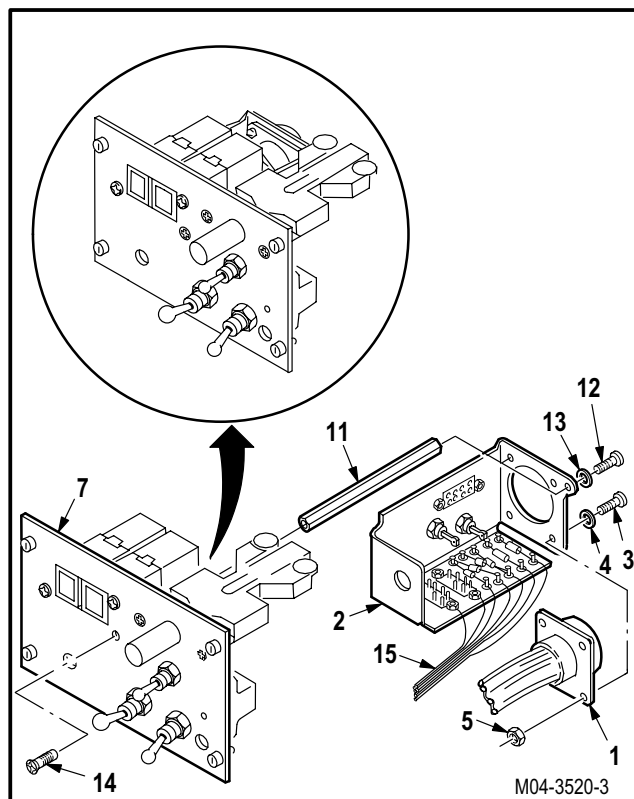

GO TO NEXT PAGE

---

**12.22. APU FIRE PANEL CIRCUIT CARD REPLACEMENT (AVIM) - continued**

---

**d. Install switch (6) on circuit card (2) and panel (7).**

- (1) Install washer (10) and lockring (9) on switch (6).
- (2) Install switch (6) so tab (16) on lockring (9) seats in locator hole (17) on circuit card (2) and panel (7).
- (3) Install nut (8) on switch (6).

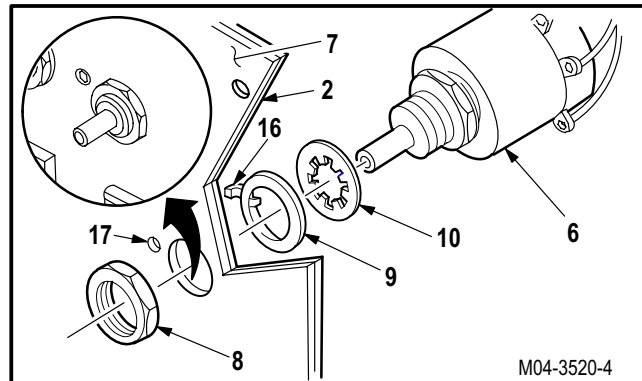

**e. Inspect (QA).**

**f. Install APU fire panel light indicating panel (para 12.18).**

END OF TASK



**12.23. ENGINE FLAME DETECTOR REPLACEMENT**

12.23.1. Description

This task covers: Removal. Cleaning. Inspection. Installation.

12.23.2. Initial Setup

**Tools:**

Aircraft mechanic's tool kit (item 376, App H)

**References:**

TM 1-1520-238-T

**Personnel Required:**

67R Attack Helicopter Repairer  
 67R3F Attack Helicopter Repairer/Technical Inspector

**Equipment Conditions:**

<u>Ref</u>	<u>Condition</u>
1.57	Helicopter safed
2.2	Access doors LN1 or RN1 opened

**NOTE**

This task is typical for all four engine flame detectors.

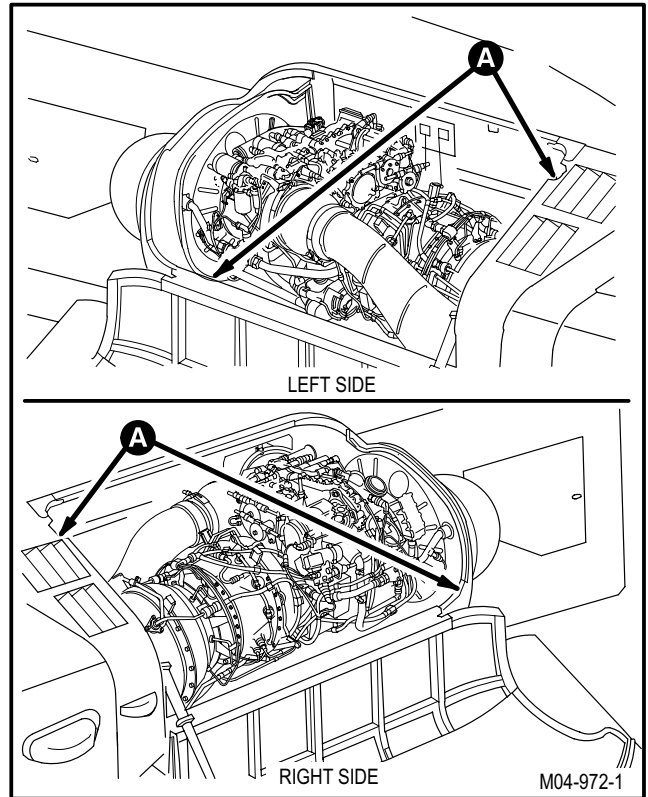

GO TO NEXT PAGE

---

**12.23. ENGINE FLAME DETECTOR REPLACEMENT - continued**

---

12.23.3. Removal

a. **Remove flame detector (1) from bracket (2).**

- (1) Detach connector (3) from receptacle (4).
- (2) Remove four screws (5), nuts (6), and washers (7).
- (3) Remove and discard detector (1).

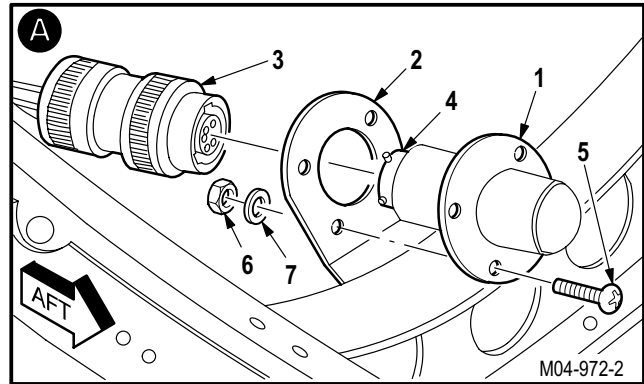

12.23.4. Cleaning

a. **Wipe removed and attaching parts with a clean rag.**

12.23.5. Inspection

- a. **Check connector for loose or bent pins** (para 12.16).
- b. **Check removed and attaching parts for corrosion** (para 1.49).

GO TO NEXT PAGE

---

**12.23. ENGINE FLAME DETECTOR REPLACEMENT - continued**

---

**12.23.6. Installation****NOTE**

Ensure forward flame detectors face up and aft, and aft flame detectors face forward and down.

**a. Install new detector (1) on bracket (2).**

- (1) Position detector (1) on bracket (2).
- (2) Install four screws (5), washers (7), and nuts (6).
- (3) Attach connector (3) to receptacle (4).

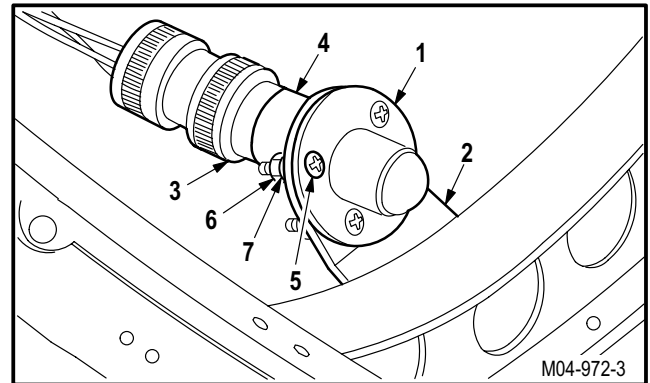
**b. Inspect (QA).****c. Perform engine 1 or engine 2 fire detection maintenance operational check (TM 1-1520-238-T).****d. Secure access doors LN1 or RN1 (para 2.2).**

END OF TASK

---

## 12.24. APU FORWARD FLAME DETECTOR REPLACEMENT

---

### 12.24.1. Description

This task covers: Removal. Cleaning. Inspection. Installation.

---

### 12.24.2. Initial Setup

#### **Tools:**

Aircraft mechanic's tool kit (item 376, App H)

#### **References:**

TM 1-1520-238-T

#### **Equipment Conditions:**

#### **Personnel Required:**

67R Attack Helicopter Repairer  
67R3F Attack Helicopter Repairer/Technical Inspector

<u>Ref</u>	<u>Condition</u>
1.57	Helicopter safed
2.2	Access doors T250L, T250R, T290L, T290R, and L325 opened

---

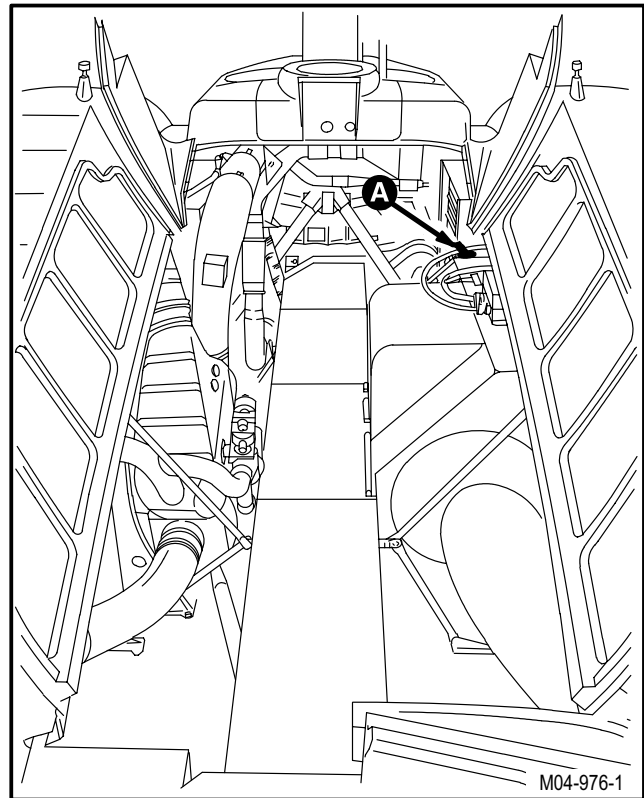

GO TO NEXT PAGE

---

**12.24. APU FORWARD FLAME DETECTOR REPLACEMENT - continued**

---

**12.24.3. Removal****a. Remove flame detector (1) from cover (2).**

- (1) Detach connector P78 (3) from receptacle (A10)J1 (4).
- (2) Remove four screws (5) and washers (6).
- (3) Remove and discard detector (1).

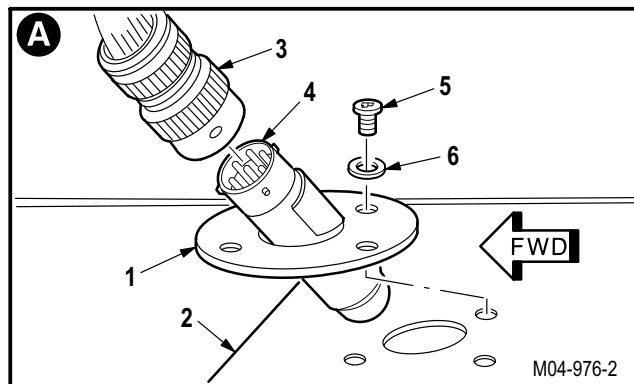
**12.24.4. Cleaning****a. Wipe removed and attaching parts with a clean rag.****12.24.5. Inspection**

- a. **Check connector for loose or bent pins** (para 12.16).
- b. **Check removed and attaching parts for corrosion** (para 1.49).

**12.24.6. Installation****a. Install new detector (1) on cover (2).**

- (1) Position detector (1) on cover (2) with receptacle (4) pointing up and forward.
- (2) Install four screws (5) and washers (6).
- (3) Attach connector P78 (3) to receptacle (A10)J1 (4).

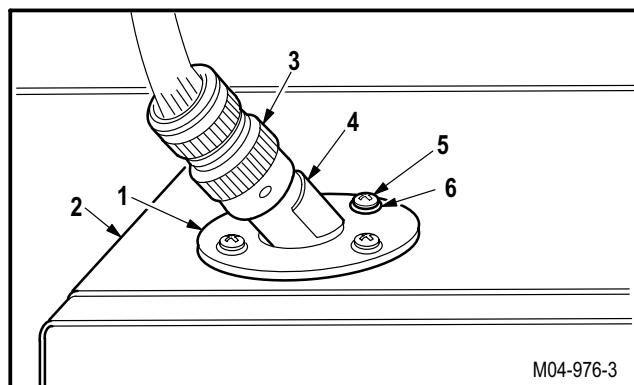
**b. Inspect (QA).****c. Perform APU fire detection maintenance operational check** (TM 1-1520-238-T).**d. Secure access doors T250L, T250R, T290L, T290R, and L325** (para 2.2).

END OF TASK

---

## 12.25. APU AFT FLAME DETECTOR REPLACEMENT

---

### 12.25.1. Description

This task covers: Removal. Cleaning. Inspection. Installation.

---

### 12.25.2. Initial Setup

#### Tools:

Aircraft mechanic's tool kit (item 376, App H)

#### References:

TM 1-1520-238-T

#### Equipment Conditions:

<u>Ref</u>	<u>Condition</u>
1.57	Helicopter safed
2.2	Access doors T250L, T250R, T290L, T290R, and L325 opened
15.41	APU upper center cover removed

#### Personnel Required:

67R Attack Helicopter Repairer  
67R3F Attack Helicopter Repairer/Technical Inspector

---

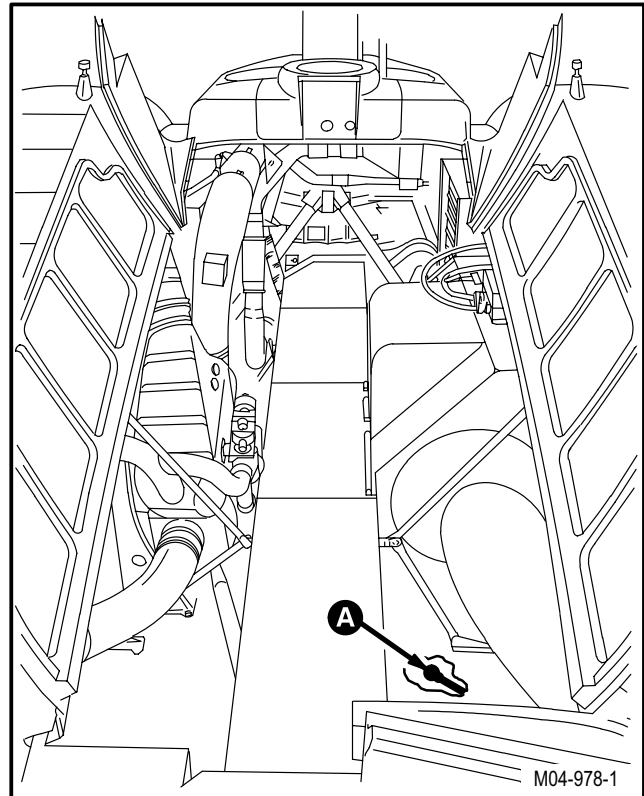

GO TO NEXT PAGE

---

**12.25. APU AFT FLAME DETECTOR REPLACEMENT - continued**

---

**12.25.3. Removal****a. Remove flame detector (1) from panel (2).**

- (1) Detach connector P79 (3) from receptacle (A11)J1 (4).
- (2) Remove four screws (5), nuts (6), and washers (7).
- (3) Remove and discard detector (1).

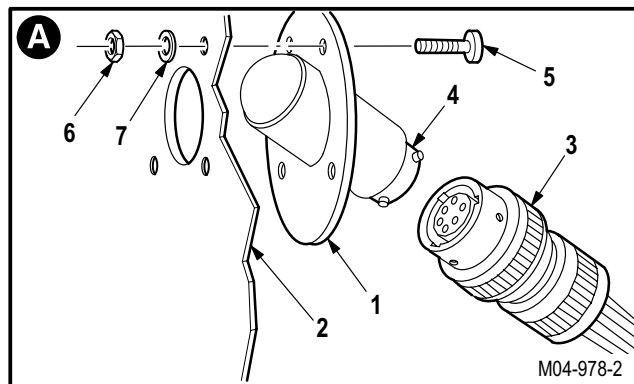
**12.25.4. Cleaning****a. Wipe removed and attaching parts with a clean rag.****12.25.5. Inspection**

- a. **Check connector for loose or bent pins** (para 12.16).
- b. **Check removed and attaching parts for corrosion** (para 1.49).

**12.25.6. Installation****a. Install new detector (1) on panel (2).**

- (1) Position detector (1) on panel (2).
- (2) Install four screws (5), washers (7), and nuts (6).
- (3) Attach connector P79 (3) to receptacle (A11)J1 (4).

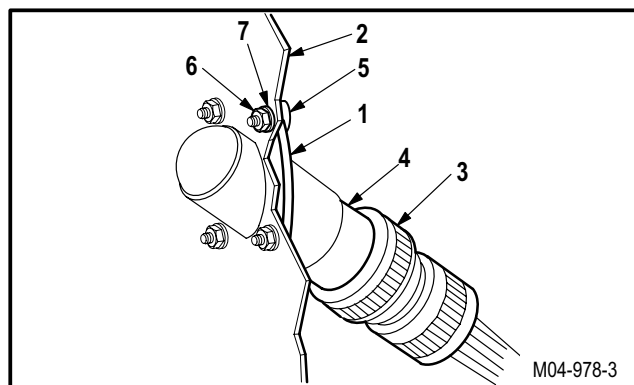
**b. Inspect (QA).****c. Perform APU fire detection maintenance operational check** (TM 1-1520-238-T).**d. Install APU upper center cover** (para 15.42).**e. Secure access doors T250L, T250R, T290L, T290R, and L325** (para 2.2).

END OF TASK

---

## 12.26. ENGINE FLAME DETECTOR CONTROL AMPLIFIER REPLACEMENT

---

### 12.26.1. Description

This task covers: Removal. Cleaning. Inspection. Installation.

---

### 12.26.2. Initial Setup

#### Tools:

Aircraft mechanic's tool kit (item 376, App H)

#### References:

TM 1-1520-238-T

#### Personnel Required:

67R Attack Helicopter Repairer  
67R3F Attack Helicopter Repairer/Technical Inspector

#### Equipment Conditions:

<u>Ref</u>	<u>Condition</u>
1.57	Helicopter safed
2.2	Access doors T250L, T250R, T290L, T290R, and L325 opened

---

### NOTE

This task is typical for either No. 1 engine or No. 2 engine flame detector control amplifier.

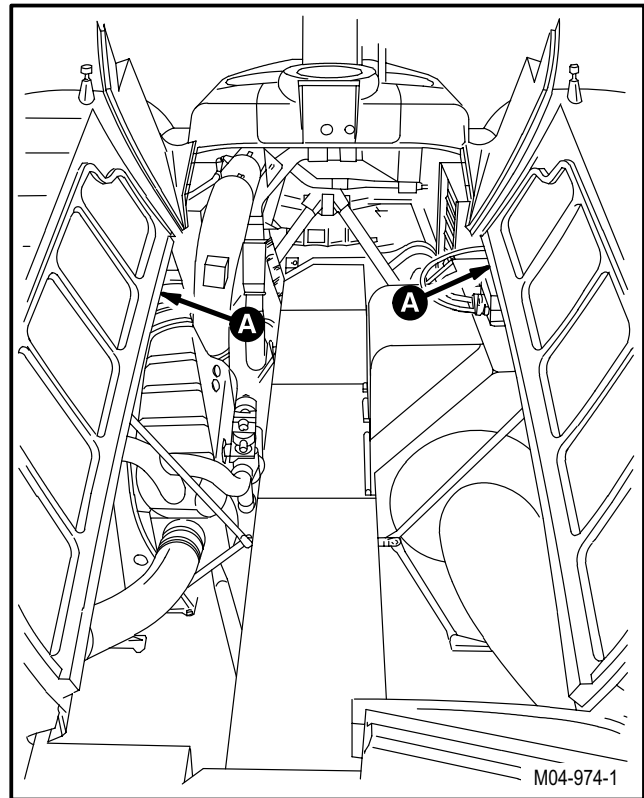

GO TO NEXT PAGE



---

**12.26. ENGINE FLAME DETECTOR CONTROL AMPLIFIER REPLACEMENT - continued**

---

**12.26.3. Removal****a. Remove control amplifier (1) from support (2).**

- (1) Detach connector (3) from receptacle (4).
- (2) Remove two screws (5) and washers (6) from amplifier (1).
- (3) Remove and discard amplifier (1).

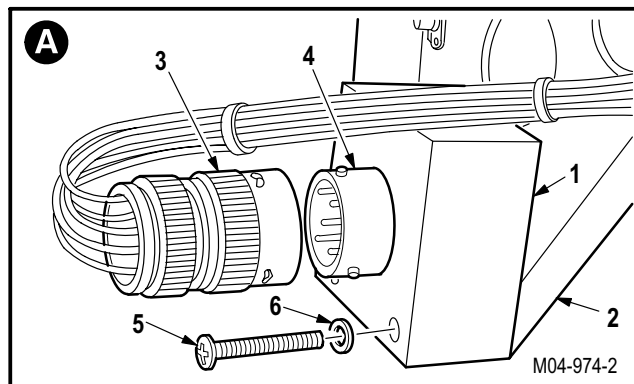
**12.26.4. Cleaning****a. Wipe removed and attaching parts with a clean rag.****12.26.5. Inspection**

- a. **Check connector for loose or bent pins** (para 12.16).
- b. **Check removed and attaching parts for corrosion** (para 1.49).

**12.26.6. Installation****a. Install amplifier (1) on support (2).**

- (1) Position amplifier (1) on support (2).
- (2) Install two screws (5) and washers (6).
- (3) Attach connector (3) to receptacle (4).

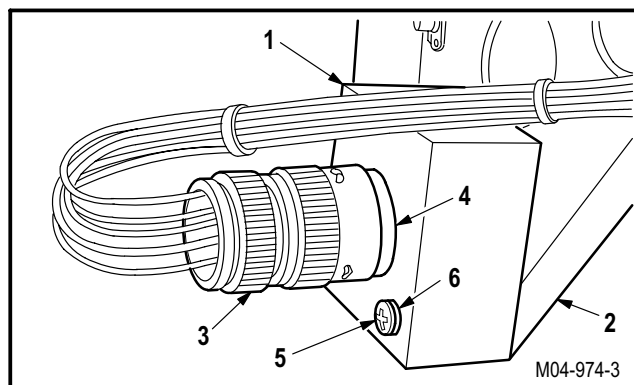
**b. Inspect (QA).****c. Perform engine 1 or engine 2 fire detection maintenance operational check** (TM 1-1520-238-T).**d. Secure access doors T250L, T250R, T290L, T290R, and L325** (para 2.2).

END OF TASK

---

## 12.27. APU FLAME DETECTOR CONTROL AMPLIFIER REPLACEMENT

---

### 12.27.1. Description

This task covers: Removal. Cleaning. Inspection. Installation.

---

### 12.27.2. Initial Setup

#### Tools:

Aircraft mechanic's tool kit (item 376, App H)

#### References:

TM 1-1520-238-T

#### Equipment Conditions:

#### Personnel Required:

67R Attack Helicopter Repairer  
67R3F Attack Helicopter Repairer/Technical Inspector

<u>Ref</u>	<u>Condition</u>
1.57	Helicopter safed
2.2	Access doors T250L, T250R, T290L, T290R, and L325 opened

---

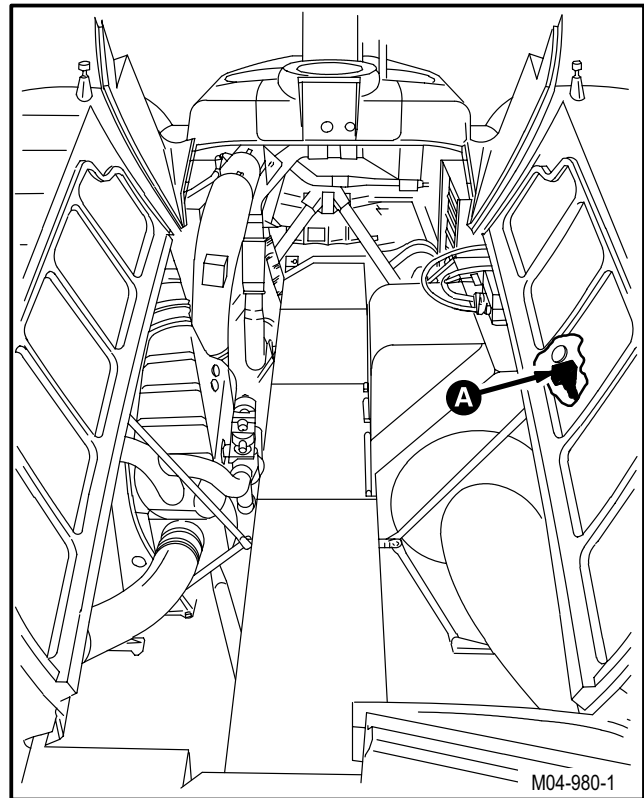

GO TO NEXT PAGE

---

**12.27. APU FLAME DETECTOR CONTROL AMPLIFIER REPLACEMENT - continued**

---

**12.27.3. Removal****a. Remove control amplifier (1) from support (2).**

- (1) Detach connector P85 (3) from receptacle (AR1)J1 (4).
- (2) Remove two screws (5) and washers (6) from amplifier (1).
- (3) Remove and discard amplifier (1).

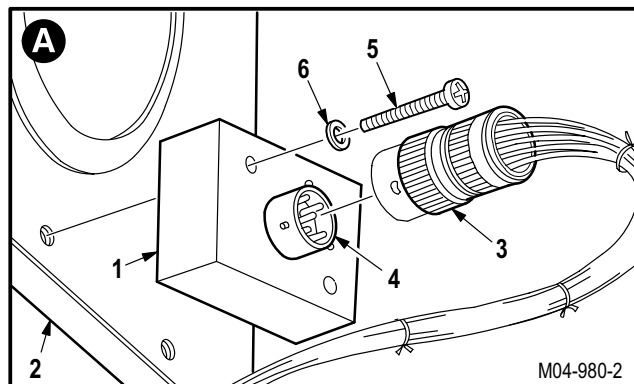
**12.27.4. Cleaning****a. Wipe removed and attaching parts with a clean rag.****12.27.5. Inspection**

- a. **Check connector for loose or bent pins** (para 12.16).
- b. **Check removed and attaching parts for corrosion** (para 1.49).

**12.27.6. Installation****a. Install amplifier (1) on support (2).**

- (1) Position amplifier (1) on support (2).
- (2) Install two screws (5) and washers (6).
- (3) Attach connector P85 (3) to receptacle (AR1)J1 (4).

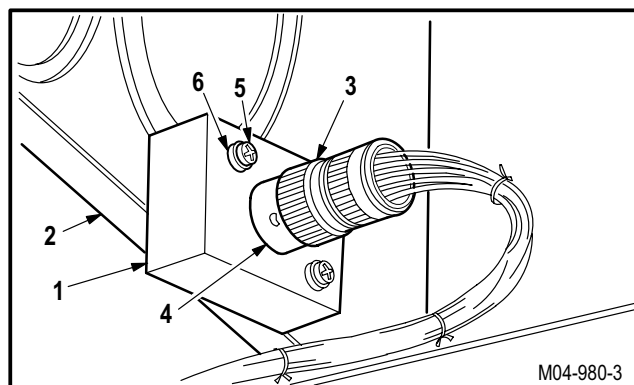
**b. Inspect (QA).****c. Perform APU fire detection maintenance operational check** (TM 1-1520-238-T).**d. Secure access doors T250L, T250R, T290L, T290R, and L325** (para 2.2).

END OF TASK

---

**12.28. LEFT ENGINE FIREWALL LOUVER FIRE/OVERHEAT DETECTOR  
REMOVAL/INSTALLATION**

---

12.28.1. Description

This task covers: Removal. Cleaning. Inspection. Installation.

---

12.28.2. Initial Setup

**Tools:**

Aircraft mechanic's tool kit (item 376, App H)

**References:**

TM 1-1520-238-T

**Equipment Conditions:**

**Personnel Required:**

67R Attack Helicopter Repairer  
67R3F Attack Helicopter Repairer/Technical  
Inspector

Ref

Condition

1.57	Helicopter safed
2.2	Access doors T250L, T250R, T290L, T290R, and L325 opened

---

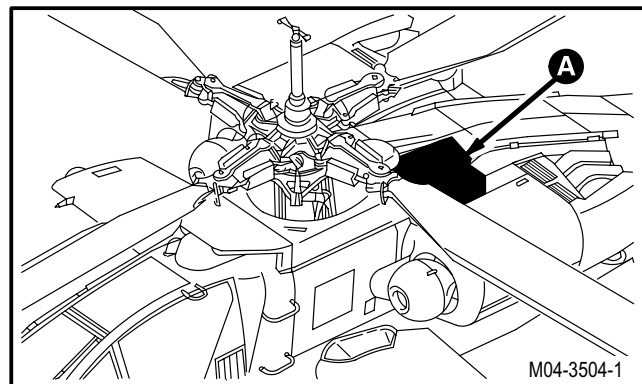

GO TO NEXT PAGE

---

**12.28. LEFT ENGINE FIREWALL LOUVER FIRE/OVERHEAT DETECTOR  
REMOVAL/INSTALLATION - continued**

---

12.28.3. Removal

**CAUTION**

Do not damage sensing element during removal. Damage may occur when bending the element. A minimum bend radius of **0.375 INCH** shall be maintained to minimize possible damage.

a. **Remove fire/overheat detector (1) from fire detector frame (2).**

- (1) Detach connector P1321 (3) from receptacle (A697)J1 (4).
- (2) Remove two screws (5), washers (6), and spacers (7).
- (3) Remove two clamps (8).
- (4) Remove detector (1) from frame (2).
- (5) Remove fire sensing element (9) from 15 spring tension clips (10).

12.28.4. Cleaning

a. **Wipe removed and attaching parts with a clean rag.**

12.28.5. Inspection

- a. **Check detector, sensing element, and frame for scratches, nicks, and gouges** (para 12.16).
- b. **Check removed and attaching parts for corrosion** (para 1.49).

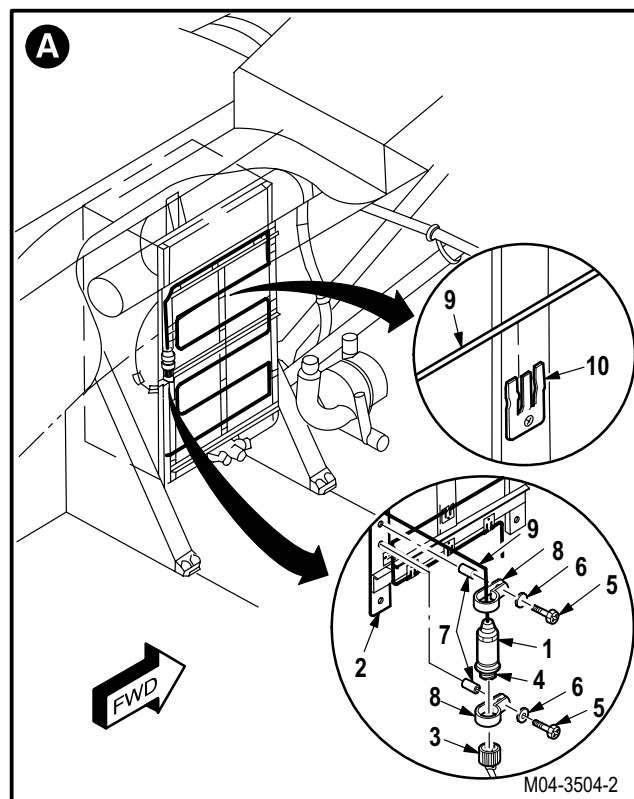

GO TO NEXT PAGE

**12.28. LEFT ENGINE FIREWALL LOUVER FIRE/OVERHEAT DETECTOR  
REMOVAL/INSTALLATION - continued**

12.28.6. Installation

**CAUTION**

Do not damage sensing element during installation. Damage may occur when bending the element. A minimum bend radius of **0.375 INCH** shall be maintained to minimize possible damage.

**a. Install detector (1) on frame (2).**

- (1) Position detector (1) so key way (11) of receptacle (A697)J1 (4) is at the inboard position.
- (2) Route sensing element (9) around frame (2). Maintain pattern as shown.
- (3) Install element (9) in 15 spring clips (10). Bend end of element toward frame (2) so a maximum of **1 INCH** protrudes.

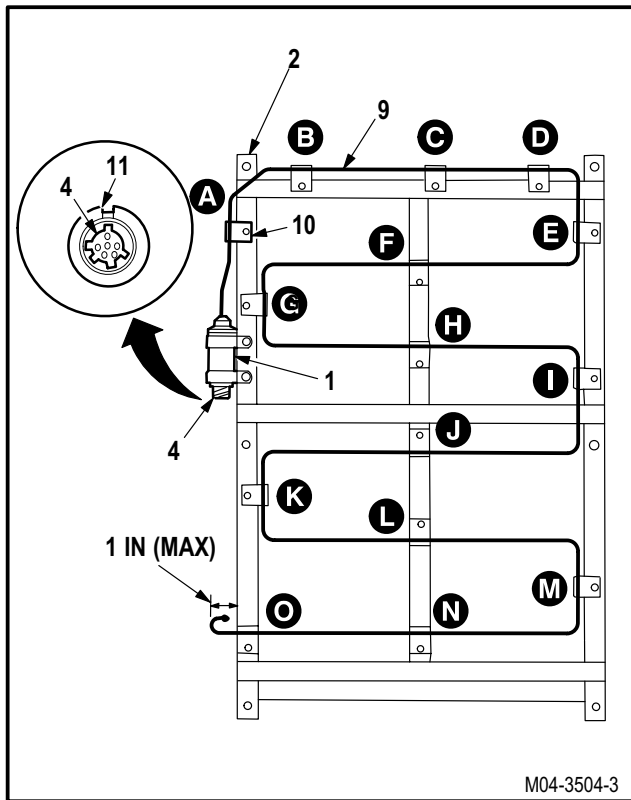

- (4) Position two clamps (8) on detector (1).
- (5) Install two screws (5) through washers (6), clamps (8), and spacers (7) to frame (2).
- (6) Attach connector P1321 (3) to receptacle (A697)J1 (4).

**b. Inspect (QA).**

- c. Perform APU fire detection maintenance operational check (TM 1-1520-238-T).**
- d. Secure access doors T250L, T250R, T290L, T290R, and L325 (para 2.2).**

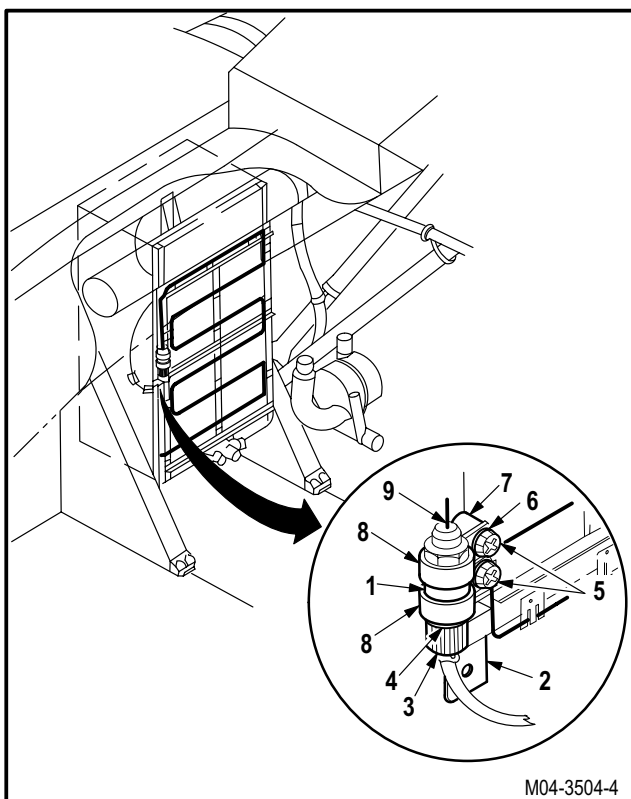

END OF TASK

---

**12.29. LEFT ENGINE FIREWALL LOUVER FIRE/OVERHEAT DETECTOR FRAME  
REMOVAL/INSTALLATION**

---

12.29.1. Description

This task covers: Removal. Cleaning. Inspection. Repair. Installation.

---

12.29.2. Initial Setup**Tools:**

Aircraft mechanic's tool kit (item 376, App H)  
Airframe repairman's tool kit (item 377, App H)

**References:**

TM 1-1500-204-23

**Personnel Required:**

67R Attack Helicopter Repairer  
68G Aircraft Structural Repairer  
67R3F Attack Helicopter Repairer/Technical  
Inspector

**Equipment Conditions:**

<u>Ref</u>	<u>Condition</u>
1.57	Helicopter safed
12.28	Left engine firewall louver fire/overheat de- tector removed

---

GO TO NEXT PAGE

**12.29. LEFT ENGINE FIREWALL LOUVER FIRE/OVERHEAT DETECTOR FRAME  
REMOVAL/INSTALLATION - continued**

12.29.3. Removal

a. **Remove clamp (1) from frame (2).**

- (1) Remove screw (3), washer (4), spacer (5), and spacer (6).
- (2) Remove clamp (1).

b. **Remove clamp (7) from frame (2).**

- (1) Remove screw (8), washer (9), and spacer (10).
- (2) Remove clamp (7).

c. **Remove bracket (11) from louver (12).**

- (1) Remove screw (13), washer (14), and spacer (15).
- (2) Remove bracket (11).

d. **Remove clamp (16) from louver (12).**

- (1) Remove screw (17), washer (18), and spacer (19).
- (2) Remove clamp (16).

e. **Remove frame (2) from louver (12).**

- (1) Remove two screws (20), washers (21), and spacers (22).
- (2) Remove frame (2).

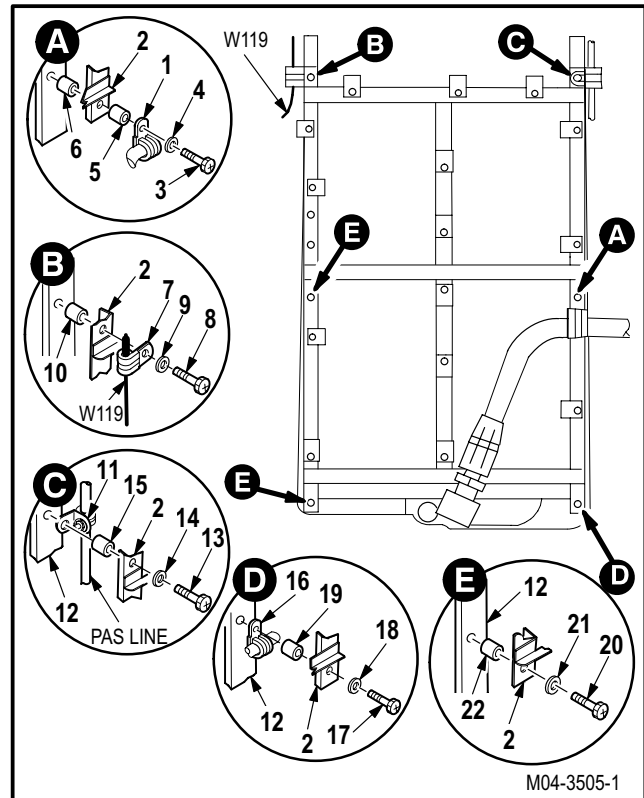

12.29.4. Cleaning

- a. **Wipe removed and attaching parts with a clean rag.**

12.29.5. Inspection

- a. **Check frame for scratches, nicks, and gouges (para 12.16).**
- b. **Check frame for damaged spring tension clips (para 12.16).**

GO TO NEXT PAGE



---

**12.29. LEFT ENGINE FIREWALL LOUVER FIRE/OVERHEAT DETECTOR FRAME  
REMOVAL/INSTALLATION - continued**

---

- c. **Check removed and attaching parts for corrosion** (para 1.49).

12.29.6. Repair**NOTE**

If spring tension clips do not require re-  
placement, go to paragraph 12.29.7.

- a. **Replace damaged spring tension clips**  
(TM 1-1500-204-23).

12.29.7. Installation

- a. **Install frame (2) on louver (12).**

- (1) Position frame (2) on louver (12).
- (2) Install two screws (20) through washers (21),  
frame (2), and spacers (22).

- b. **Install clamp (16) on louver (12).**

- (1) Install screw (17) through washer (18), frame  
(2), spacer (19), and clamp (16).

- c. **Install bracket (11) on louver (12).**

- (1) Install screw (13) through washer (14), frame  
(2), spacer (15), and bracket (11).

- d. **Install clamp (7) on frame (2).**

- (1) Install screw (8) through washer (9), clamp  
(7), frame (2), and spacer (10).

- e. **Install clamp (1) on frame (2).**

- (1) Install screw (3) through washer (4), clamp  
(1), spacer (5), frame (2), and spacer (6).

- f. **Inspect (QA).**

- g. **Install left engine firewall louver fire/overheat  
detector** (para 12.28).

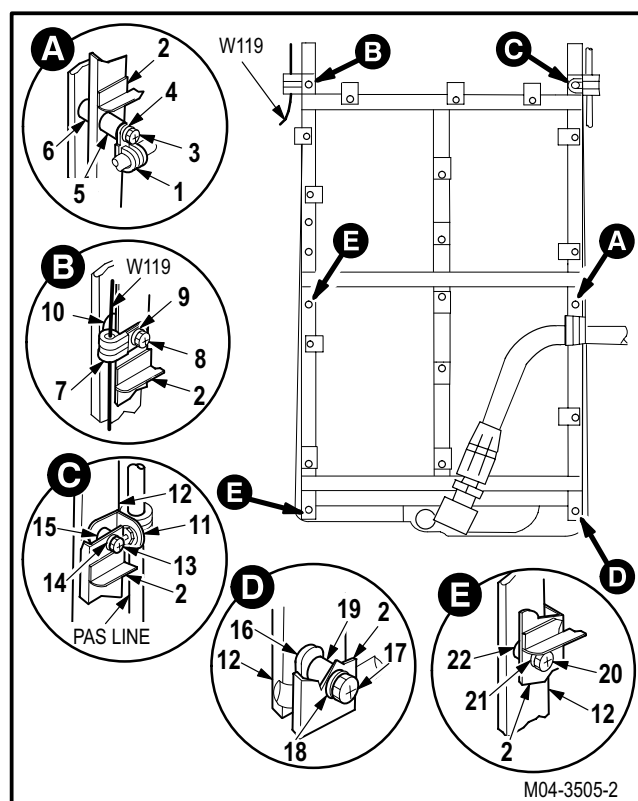

END OF TASK

---

**12.30. RIGHT ENGINE FIREWALL LOUVER FIRE/OVERHEAT DETECTOR  
REMOVAL/INSTALLATION**

---

12.30.1. Description

This task covers: Removal. Cleaning. Inspection. Installation.

---

12.30.2. Initial Setup

**Tools:**

Aircraft mechanic's tool kit (item 376, App H)

**References:**

TM 1-1520-238-T

**Equipment Conditions:**

**Personnel Required:**

67R Attack Helicopter Repairer  
67R3F Attack Helicopter Repairer/Technical  
Inspector

Ref

Condition

1.57 Helicopter safed  
2.2 Access doors T250L, T250R, T290L,  
T290R, and L325 opened

---

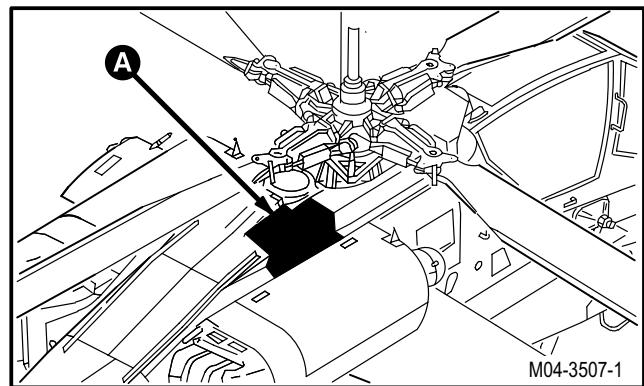

GO TO NEXT PAGE

## 12.30. RIGHT ENGINE FIREWALL LOUVER FIRE/OVERHEAT DETECTOR REMOVAL/INSTALLATION - continued

### 12.30.3. Removal

#### CAUTION

Do not damage sensing element during removal. Damage may occur when bending the element. A minimum bend radius of **0.375 INCH** shall be maintained to minimize possible damage.

#### a. Remove fire/overheat detector (1) from fire detector frame (2).

- (1) Detach connector P1320 (3) from receptacle (A698)J1 (4).
- (2) Remove two screws (5), washers (6), and spacers (7).
- (3) Remove two clamps (8).
- (4) Remove detector (1) from frame (2).
- (5) Remove fire sensing element (9) from 19 spring tension clips (10).

### 12.30.4. Cleaning

#### a. Wipe removed and attaching parts with a clean rag.

### 12.30.5. Inspection

- a. Check detector, sensing element, and frame for scratches, nicks, and gouges (para 12.16).
- b. Check removed and attaching parts for corrosion (para 1.49).

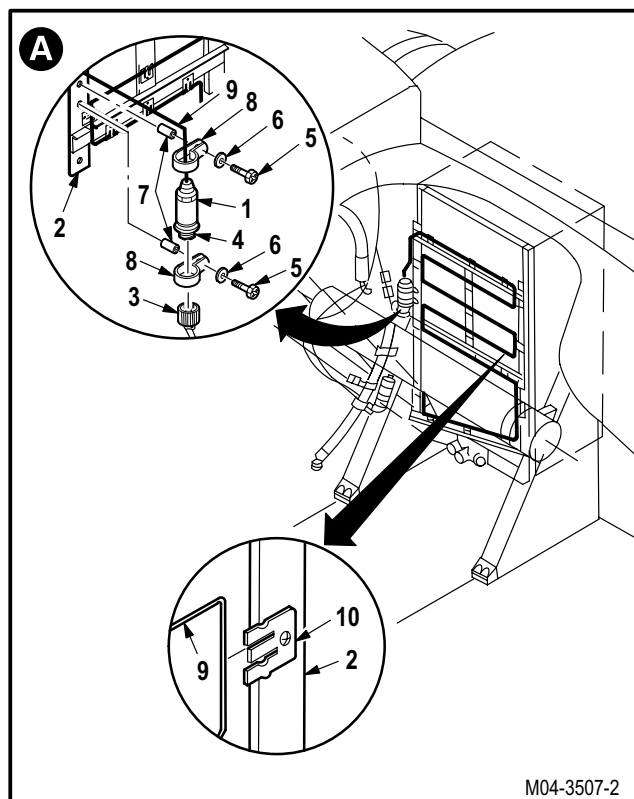

GO TO NEXT PAGE

**12.30. RIGHT ENGINE FIREWALL LOUVER FIRE/OVERHEAT DETECTOR  
REMOVAL/INSTALLATION - continued**

12.30.6. Installation

**CAUTION**

Do not damage sensing element during installation. Damage may occur when bending the element. A minimum bend radius of **0.375 INCH** shall be maintained to minimize possible damage.

**a. Install detector (1) on frame (2).**

- (1) Position detector (1) so key way (11) of receptacle (A698)J1 (4) is at the inboard position.
- (2) Route sensing element (9) around frame (2). Maintain pattern as shown.
- (3) Install element (9) in 19 frame clips (10).

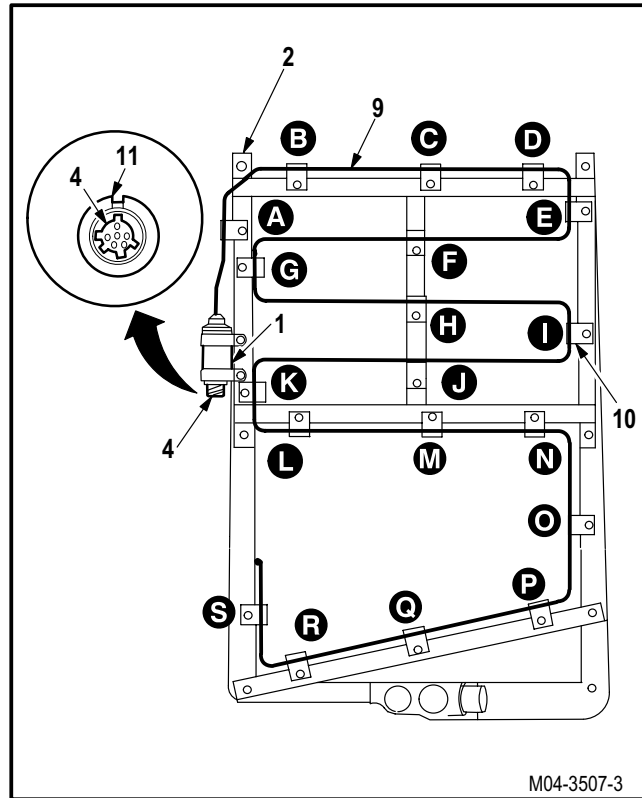

- (4) Position two clamps (8) on detector (1).
- (5) Install two screws (5) through washers (6), clamps (8), and spacers (7) to frame (2).
- (6) Attach connector P1320 (3) to receptacle (A698)J1 (4).

**b. Inspect (QA).**

**c. Perform APU fire detection maintenance operational check (TM 1-1520-238-T).**

**d. Secure access doors T250L, T250R, T290L, T290R, and L325 (para 2.2).**

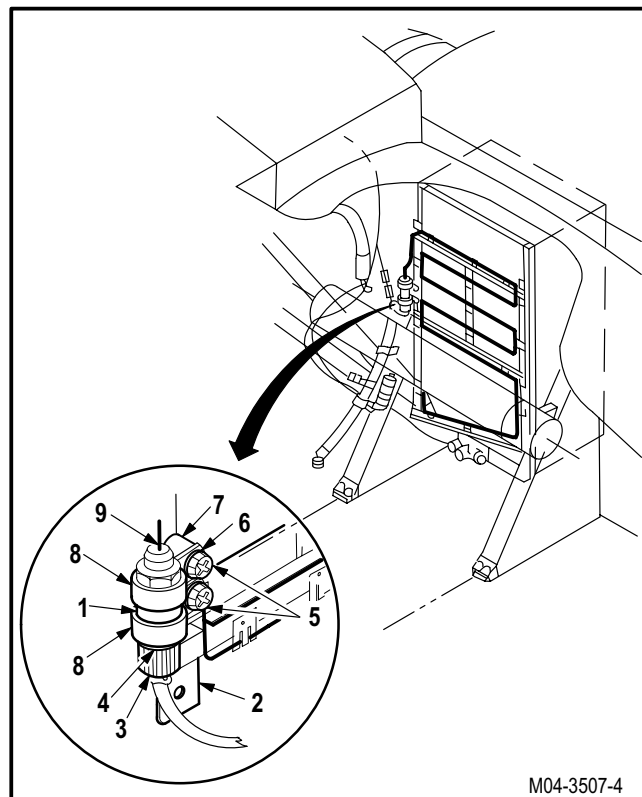

END OF TASK

---

## 12.31. RIGHT ENGINE FIREWALL LOUVER FIRE/OVERHEAT DETECTOR FRAME REMOVAL/INSTALLATION

---

### 12.31.1. Description

This task covers: Removal. Cleaning. Inspection. Repair. Installation.

---

### 12.31.2. Initial Setup

#### **Tools:**

Aircraft mechanic's tool kit (item 376, App H)  
Airframe repairman's tool kit (item 377, App H)

#### **References:**

TM 1-1500-204-23

#### **Personnel Required:**

67R	Attack Helicopter Repairer
68G	Aircraft Structural Repairer
67R3F	Attack Helicopter Repairer/Technical Inspector

#### **Equipment Conditions:**

<u>Ref</u>	<u>Condition</u>
1.57	Helicopter safed
12.30	Right engine firewall louver fire/overheat detector removed

---

GO TO NEXT PAGE

**12.31. RIGHT ENGINE FIREWALL LOUVER FIRE/OVERHEAT DETECTOR FRAME  
REMOVAL/INSTALLATION - continued**

12.31.3. Removal

a. **Remove clamp (1) from upper detector frame (2).**

(1) Remove screw (3), washer (4), and spacer (5).

(2) Remove clamp (1) from frame (2).

b. **Remove clamp (6) from lower detector frame (7).**

(1) Remove screw (8), washer (9), and spacer (10).

(2) Remove clamp (6) from frame (7).

c. **Remove frames (2) and (7) from louver (11).**

(1) Remove four screws (12), washers (13), and spacers (14).

(2) Remove frames (2) and (7).

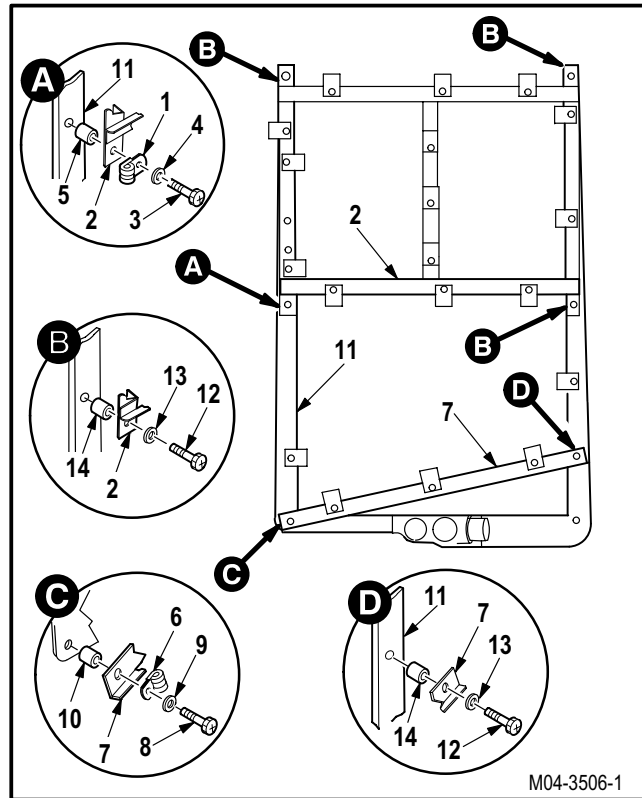

M04-3506-1

12.31.4. Cleaning

a. **Wipe removed and attaching parts with a clean rag.**

12.31.5. Inspection

a. **Check frame for scratches, nicks, and gouges (para 12.16).**

b. **Check frame for damaged spring tension clips (para 12.16).**

c. **Check removed and attaching parts for corrosion (para 1.49).**

GO TO NEXT PAGE

---

**12.31. RIGHT ENGINE FIREWALL LOUVER FIRE/OVERHEAT DETECTOR FRAME  
REMOVAL/INSTALLATION - continued**

---

12.31.6. Repair**NOTE**

If spring tension clips do not require re-  
placement, go to paragraph 12.31.7.

- a. **Replace damaged spring tension clips**  
(TM 1-1500-204-23).

12.31.7. Installation

- a. **Install frames (2) and (7) on louver (11).**

- (1) Position frames (2) and (7) on louver (11).
- (2) Install four screws (12) through washers (13), frames (2) and (7), and spacers (14).

- b. **Install clamp (6) on frame (7).**

- (1) Install screw (8) through washer (9), clamp (6), and spacer (10).

- c. **Install clamp (1) on frame (2).**

- (1) Install screw (3) through washer (4), clamp (1), and spacer (5).

- d. **Inspect (QA).**

- e. **Install right engine firewall louver fire/over-  
heat detector (para 12.30).**

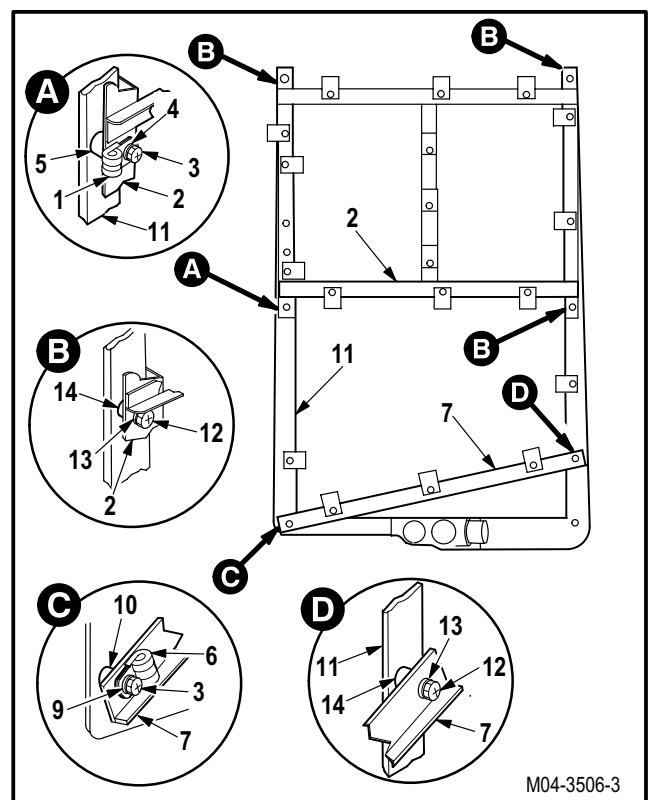

END OF TASK

---

## 12.32. MAIN DECK FIRE/OVERHEAT DETECTOR REMOVAL/INSTALLATION

---

### 12.32.1. Description

This task covers: Removal. Cleaning. Inspection. Installation.

---

### 12.32.2. Initial Setup

#### **Tools:**

Aircraft mechanic's tool kit (item 376, App H)

#### **References:**

TM 1-1520-238-T

#### **Equipment Conditions:**

<u>Ref</u>	<u>Condition</u>
1.57	Helicopter safed
2.2	Access doors T250L, T250R, T290L, T290R, and L325 opened; panels L200 and R200 removed

#### **Personnel Required:**

67R Attack Helicopter Repairer  
67R3F Attack Helicopter Repairer/Technical Inspector

---

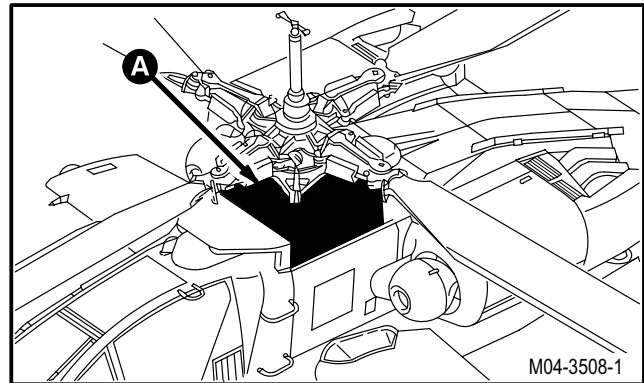

GO TO NEXT PAGE



**12.32. MAIN DECK FIRE/OVERHEAT DETECTOR REMOVAL/INSTALLATION - continued**

12.32.3. Removal

**CAUTION**

Do not damage sensing element during removal. Damage may occur when bending the element. A minimum bend radius of **0.375 INCH** shall be maintained to minimize possible damage.

**a. Remove fire/overheat detector (1) from support (2).**

- (1) Detach connector P1322 (3) from receptacle (A699)J1 (4).
- (2) Remove two nuts (5), washers (6), screws (7), clamps (8), and spacers (9).

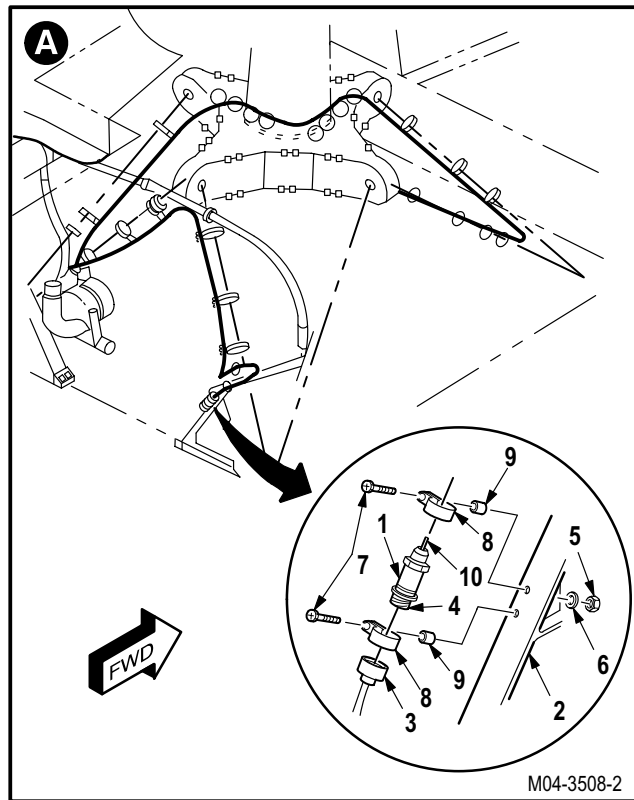

- (3) Remove fire sensing element (10) from 24 spring tension clips (11).

**NOTE**

- If spring tension clips do not require replacement, go to paragraph 12.32.4.
- Step b applies to all 24 spring tension clips.

**b. Remove spring tension clip (11) from clamp (12).**

- (1) Remove nut (13), washer (14), and screw (15).
- (2) Remove and discard clip (11).

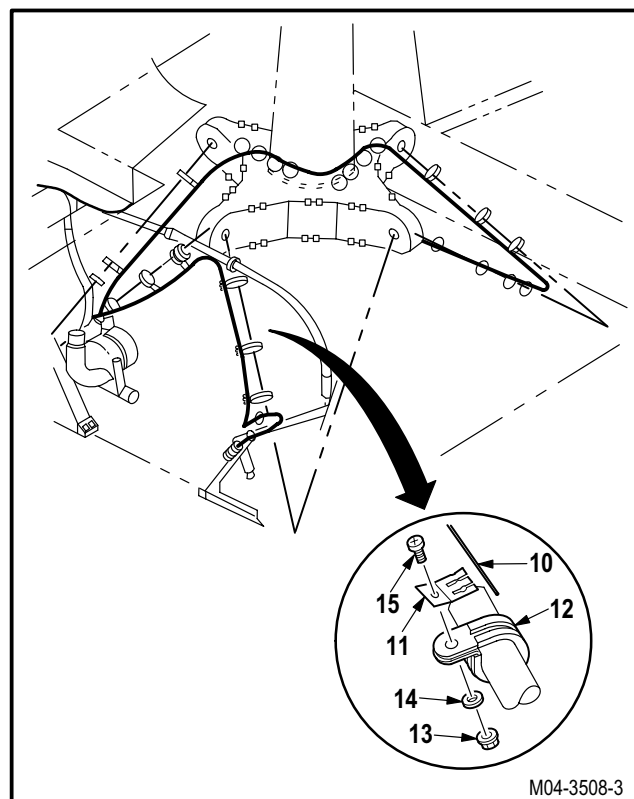

GO TO NEXT PAGE

---

**12.32. MAIN DECK FIRE/OVERHEAT DETECTOR REMOVAL/INSTALLATION - continued**

---

12.32.4. Cleaning

- a. **Wipe removed and attaching parts with a clean rag.**

12.32.5. Inspection

- a. **Inspect detector and sensing element for scratches, nicks, and gouges** (para 12.16).
- b. **Check for damaged spring tension clips** (para 12.16).
- c. **Check removed and attaching parts for corrosion** (para 1.49).

12.32.6. Installation

**NOTE**

- Step a applies to all 24 spring tension clips.
- If spring tension clips were not removed, go to step b.

a. **Install new clip (11) on clamp (12).**

- (1) Position clip (11) on clamp (12).
- (2) Install screw (15) through clip (11), clamp (12), washer (14), and nut (13).

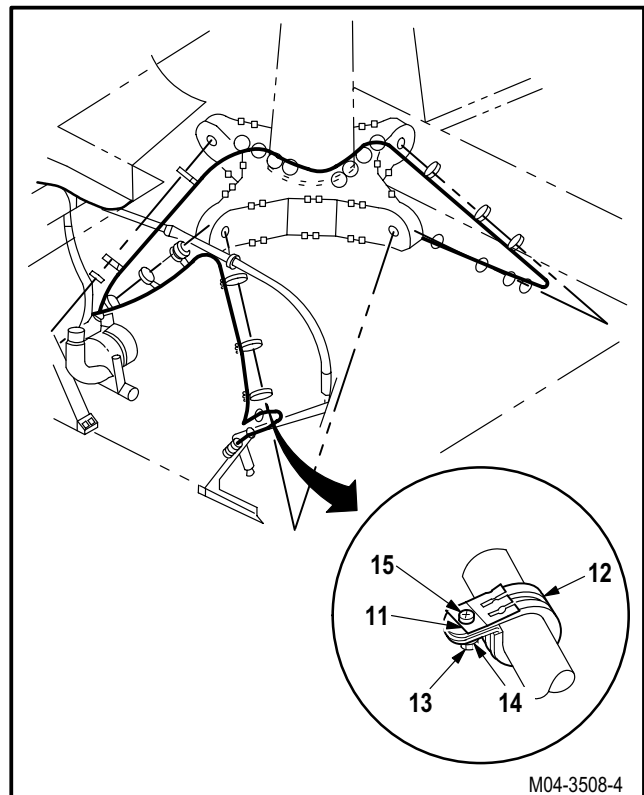

GO TO NEXT PAGE

---

**12.32. MAIN DECK FIRE/OVERHEAT DETECTOR REMOVAL/INSTALLATION - continued**

---

**CAUTION**

Do not damage sensing element during installation. Damage may occur when bending the element. A minimum bend radius of **0.375 INCH** shall be maintained to minimize possible damage.

**b. Install detector (1) on support (2).**

- (1) Position detector (1) so keyway (16) of receptacle (A699)J1 (4) is at the inboard position.
- (2) Install two clamps (8) on detector (1).
- (3) Install two screws (7) through clamps (8), spacers (9), support (2), washers (6), and nuts (5).
- (4) Route sensing element (10) around struts (17). Maintain pattern as shown.
- (5) Install element (10) in 24 clips (11).
- (6) Attach connector P1322 (3) to receptacle (A699)J1 (4).

**c. Inspect (QA).**

- d. **Perform APU fire detection maintenance operational check** (TM 1-1520-238-T).
- e. **Secure access doors T250L, T250R, T290L, T290R, and L325; install panels L200 and R200** (para 2.2).

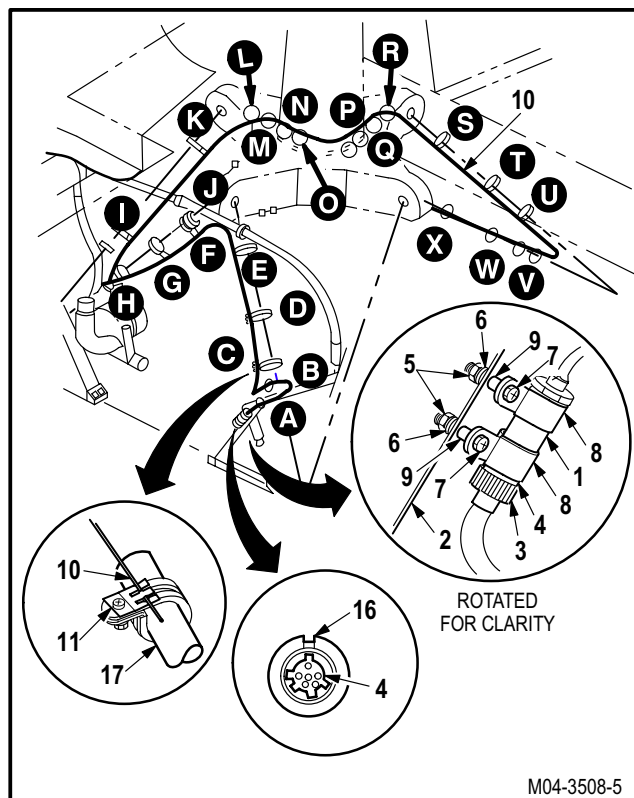

END OF TASK

## SECTION III. FIRE EXTINGUISHING SYSTEM MAINTENANCE

### 12.33. FIRE EXTINGUISHING SYSTEM INSPECTION

#### 12.33.1. Description

This task covers: Inspection.

#### 12.33.2. Initial Setup

##### Tools:

Aircraft mechanic's tool kit (item 376, App H)  
 Light duty laboratory apron (item 27, App H)  
 Chemical protective gloves (item 154, App H)  
 Industrial goggles (item 156, App H)  
 Adjustable air filtering respirator (item 262, App H)

##### Personnel Required:

67R Attack Helicopter Repairer  
 67R3F Attack Helicopter Repairer/Technical Inspector

##### References:

TM 55-1500-323-24

##### Materials/Parts:

Acetone (item 1A, App F)  
 Brush (item 34, App F)  
 Corrosion removing compound (item 64B, App F)  
 Epoxy primer coating kit (item 77, App F)  
 Mat (item 122, App F)

##### Equipment Conditions:

<u>Ref</u>	<u>Condition</u>
1.57	Helicopter safed
2.2	Access doors T250L, T250R, T290L, T290R, and L325 opened

#### 12.33.3. Inspection

- a. **Check engine fire pull switches for cracks and broken or loose terminals.** None allowed.
- b. **Check fire bottle select switch for illegible lettering and loose mounting.** None allowed.
- c. **Check thermal discharge indicator disk for cracks or missing disk.** None allowed.
- d. **Check check valves for cracks and stripped or damaged threads.** None allowed.
- e. **Check check valves for nicks, scratches, and marks.** Minor surface damage that does not exceed a depth of **0.040 INCH** or 10 percent of material thickness, is permissible.
- f. **Check the interior of two way check valves for evidence of cracks, pitting, corrosion and evaporation.**

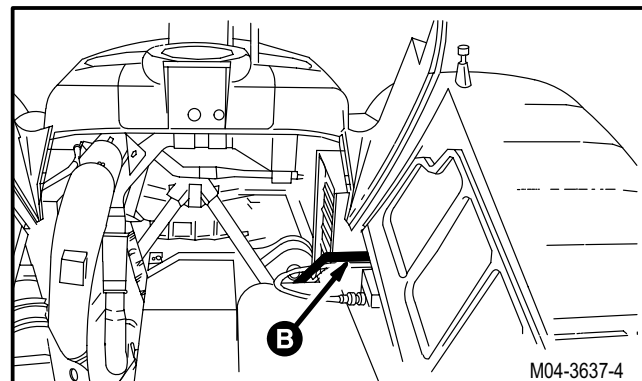
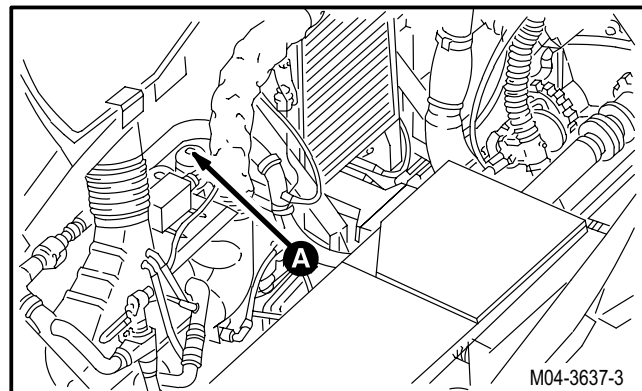

GO TO NEXT PAGE

**12.33. FIRE EXTINGUISHING SYSTEM INSPECTION - continued**

- (1) Rapidly move each check valve from side to side to insure unrestricted movement of the check valve ball. No restriction allowed.
- (2) Visually inspect the check valve ball for pitting. None allowed.
- (3) Using a 10X magnifying glass, inspect the threads for cracks. None allowed.
- (4) Visually inspect interior surface of the valve for corrosion and evidence of evaporation. None allowed.
- (5) Visually inspect interior surfaces for pitting, including the ball seats. None allowed.

g. **Check agent container for dents, cracks, scratches, or gouges.** None allowed.

h. **Visually inspect the inside of the fire bottle cartridge housing for pitting, corrosion and evaporation.** None allowed.

i. **Visually inspect the verticle outlet ports for pitting, corrosion and evaporation.** None allowed.

j. **Check discharge cartridge for cracks, nicks, scratches, and stripped or damaged threads.** None allowed.

k. **Check tubes for cracks.** None allowed.

l. **Check tubes for dents that exceed 20 percent of tube diameter.** None allowed.

m. **Check tubes for nicks that exceed 10 percent of tube wall thickness.** None allowed.

n. **Check tubes for chafing conditions.** None allowed.

o. **Check tubes for wear that exceeds 0.020 INCH.** None allowed.

p. **Check wires for cuts, nicks, fraying, or chafing (TM 55-1500-323-24).**

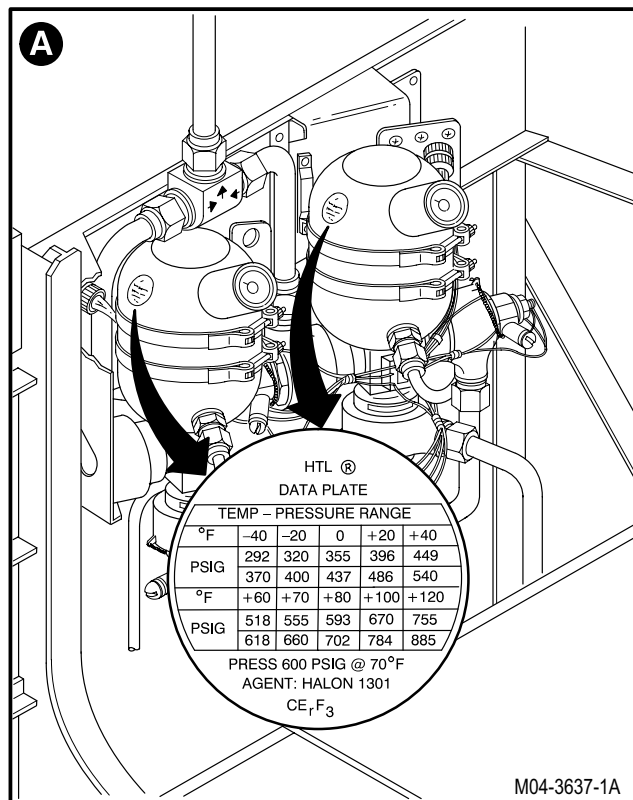

GO TO NEXT PAGE

**12.33. FIRE EXTINGUISHING SYSTEM INSPECTION - continued**

- q. **Check pressure gage for cracks.** None allowed.
- r. **Check pressure gage for required pressure.**
- s. **Check fire extinguisher electronic modules for damage and security of attachment.** If damaged or loose, replace or bond module (para 12.41).
- t. **Check general mounting hardware for cracks, gouges, nicks, scratches, chafing, damage, rounded flats, and stripped or damaged threads.** Replace damaged hardware.
- u. **Check fire extinguisher tubing for chafing on ENCU.**
  - (1) Minimum clearance between tubing and ENCU **0.25 INCH.**
- v. **Check fire extinguisher tubing for chafing on PAS tube.**
  - (1) Minimum clearance between tubing and PAS tube **0.25 INCH.**

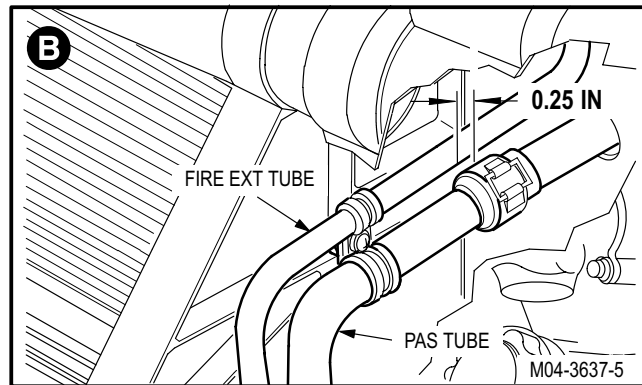
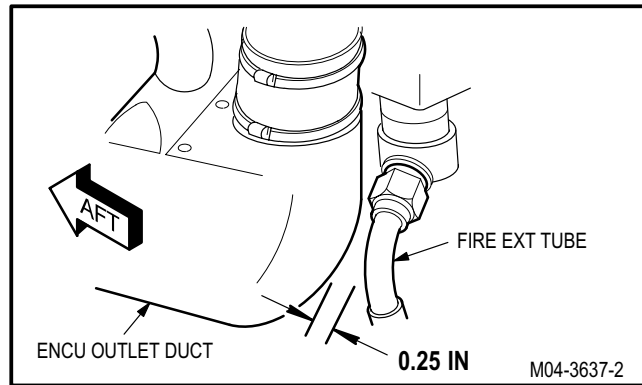

GO TO NEXT PAGE

---

**12.33. FIRE EXTINGUISHING SYSTEM INSPECTION - continued**

---

**w. Check fire extinguisher tubes for corrosion.**

- (1) If corroded, remove tubes (para 12.38) and clean as follows:



**CAUTION**

Do not use strong solvents (MEK, Trichloroethane, etc.) to clean the tube assemblies. Do not forcefully scrub the surfaces to be inspected. Protect nearby wiring and exposed parts from splashing or spillage of detergents and cleaning compounds.

**NOTE**

Proper cleaning of the tube is necessary to determine the extent of corrosion damage and to determine the appropriate corrective action.

- (a) Remove built-up corrosion from tube with a non-metallic abrasive mat. Use mat (item 122, App F).
- (b) Clean tubes with acetone. Use acetone (item 1A, App F) or equivalent.
- (c) Corroded areas inside the tube that are not accessible require tube replacement.
- (d) Visually inspect the cleaned area using a 5X magnifier. Ensure all corrosion is removed.
- (e) After all corrosion has been removed, inspect for allowable damage.

- 1 If the repair exceeds 10 percent (**0.003 INCH**) of the tube wall thickness, replace tube.



**WARNING**

**Chemicals/acids can burn eyes and skin. All personnel must wear safety goggles and gloves when using chemicals/acids. If contact is made with skin or eyes, wash chemical off with water and seek medical aid. Read and comply with chemical/solvent label instructions and warnings.**

- (f) If damage is within allowable limits and all corrosion has been removed, apply corrosion removing compound to the damaged surfaces, both inside and outside. Use corrosion removing compound (item 64B, App F) and brush (item 34, App F) or equivalent.
- (g) Allow the treatment to deoxidize for approximately **30 MINUTES**.
- (h) Rinse thoroughly with tap water and allow to air dry.
- (i) Apply epoxy primer coating to all deoxidized/damaged surfaces. Use epoxy primer coating (item 77, App F).
- (j) Allow primer to dry and reinstall the tube (para 12.39).

END OF TASK

---

**12.34. PILOT ENGINE FIRE PULL SWITCH REMOVAL/INSTALLATION**

---

12.34.1. Description

This task covers: Removal. Cleaning. Inspection. Installation.

---

12.34.2. Initial Setup

**Tools:**

Electrical tool kit (item 378, App H)  
 Light duty laboratory apron (item 27, App H)  
 Chemical protective gloves (item 154, App H)  
 Electric gun type heater (item 163, App H)  
 Adjustable air filtering respirator (item 262, App H)  
 Soldering gun (item 334, App H)

**Personnel Required:**

68X Armament/Electrical System Repairer  
 One person to assist  
 68X3F Armament/Electrical System Repairer/  
 Technical Inspector

**References:**

TM 1-1520-238-T  
 TM 55-1500-323-24

**Materials/Parts:**

Splice (2)  
 Insulation sleeving (item 105, App F)  
 Solder (item 189, App F)

**Equipment Conditions:**

<u>Ref</u>	<u>Condition</u>
1.57	Helicopter safed
2.179	Nontransparent barrier removed

**NOTE**

This task is typical for No. 1 or No. 2 pilot engine fire pull switch.

12.34.3. Removal

- a. **Enter pilot station (para 1.56). Observe all safety precautions.**
- b. **On pilot center circuit breaker panel, open FIRE EXTGH PLT, CPG, and APU circuit breakers.**

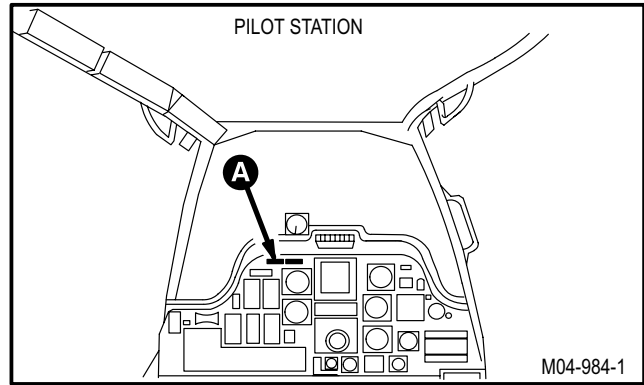

GO TO NEXT PAGE



---

**12.34. PILOT ENGINE FIRE PULL SWITCH REMOVAL/INSTALLATION - continued**

---

**NOTE**

Both engine fire pull switches must be removed from instrument panel to allow maintenance on either switch.

**c. Remove handle (1) from engine fire pull switch (2).**

- (1) Pull handle (1) to extended position.
- (2) Remove screw (3).
- (3) Remove handle (1).

**d. Remove switch (2) from instrument panel (4).**

- (1) Remove two screws (5).
- (2) Remove switch (2).

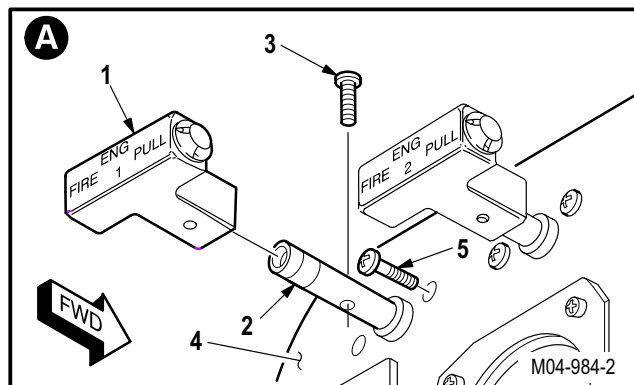

GO TO NEXT PAGE

12.34. PILOT ENGINE FIRE PULL SWITCH REMOVAL/INSTALLATION - continued

- e. Enter CPG station (para 1.56). Observe all safety precautions.



**WARNING**

**Soldering gun can cause severe burns to personnel and start fires. Observe all safety precautions when using soldering gun. If injury occurs, seek medical aid.**

- f. Desolder wires (6) from switch (2).

- (1) Remove sleeving (7) from wires (6).
- (2) Identify and desolder wires (6) from terminals (8). Use soldering gun (TM 55-1500-323-24).

- g. Identify and detach two wires (9) from wires (10).

- (1) Remove and discard two splices (11) (TM 55-1500-323-24).

12.34.4. Cleaning

- a. Wipe removed and attaching parts with a clean rag.

12.34.5. Inspection

- a. Check switches for cracks and broken or loose terminals (para 12.33).
- b. Check wires for cuts, nicks, fraying, or chafing (para 12.33).
- c. Check removed and attaching parts for corrosion (para 1.49).

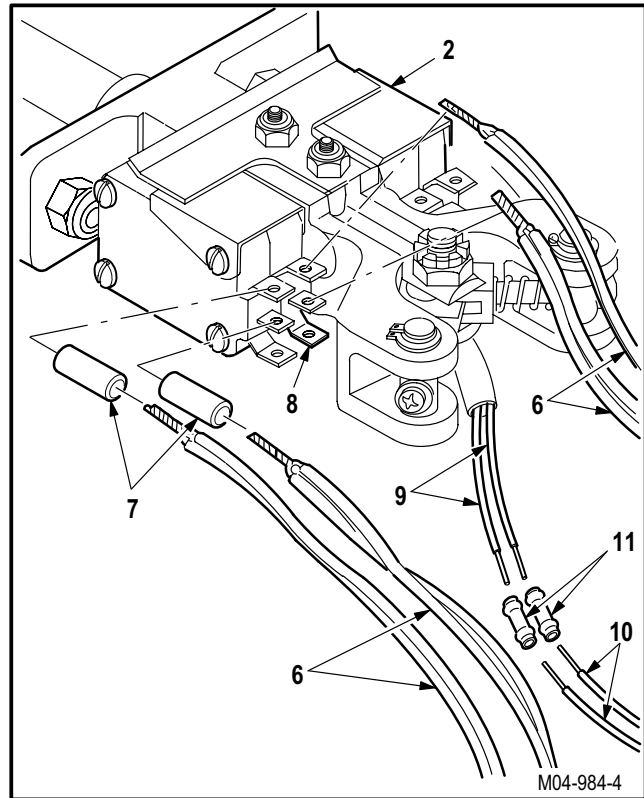

GO TO NEXT PAGE

---

**12.34. PILOT ENGINE FIRE PULL SWITCH REMOVAL/INSTALLATION - continued**

---

12.34.6. Installation**NOTE**

If replacing switch, go to paragraph 12.34.3 to remove handle from new switch.

- a. **Enter CPG station** (para 1.56). **Observe all safety precautions.**



**WARNING**

- **Soldering gun can cause severe burns to personnel and start fires. Observe all safety precautions when using soldering gun. If injury occurs, seek medical aid.**
  - **Do not place heater near flammable material or allow heater to contact skin: severe burns can result. Wear protective equipment. If injury occurs, seek medical aid.**
- b. **Solder wires (6) to switch (2).**
- (1) Install sleeving (7) on wires (6). Use insulation sleeving (item 105, App F).
  - (2) Solder identified wires (6) to terminals (8). Use soldering gun and solder (item 189, App F) (TM 55-1500-323-24).
  - (3) Position sleeving (7) on terminals (8) and shrink. Use heater.
- c. **Attach two identified wires (9) to wires (10).**
- (1) Install two new splices (11) (TM 55-1500-323-24).

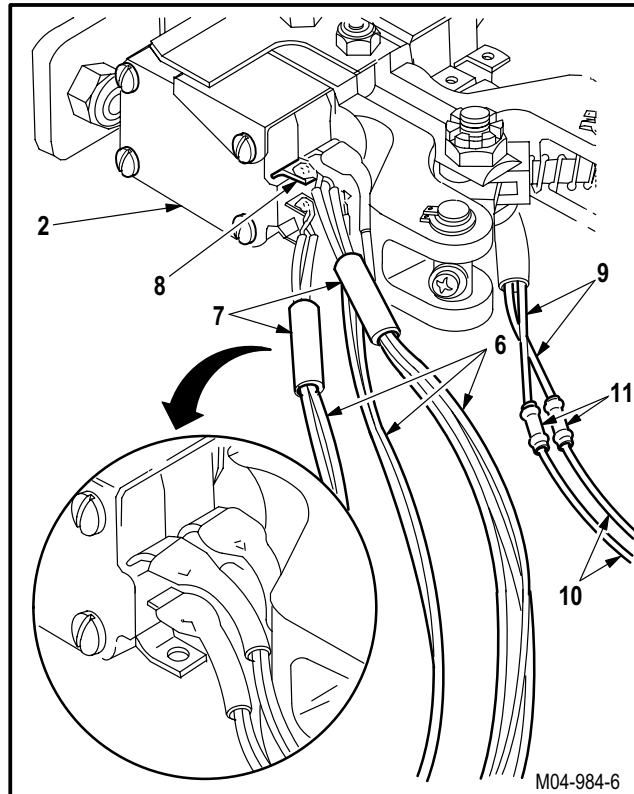

GO TO NEXT PAGE

---

**12.34. PILOT ENGINE FIRE PULL SWITCH REMOVAL/INSTALLATION - continued**

---

**d. Position switch (2) on panel (4).**

- (1) Position switch (2) on panel (4).
- (2) One person hold switch (2).

**e. Enter pilot station (para 1.56). Observe all safety precautions.**

**f. Install switch (2) on panel (4).**

- (1) Install two screws (5).

**g. Install handle (1) on switch (2).**

- (1) Install handle (1) on switch (2).
- (2) Install screw (3).
- (3) Push handle (1) to retracted position.

**h. Inspect (QA).**

**i. Perform fire extinguishers maintenance operational check (TM 1-1520-238-T).**

**j. Install nontransparent barrier (para 2.179).**

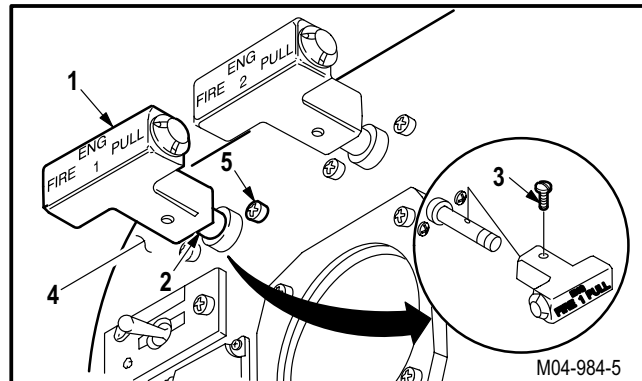

END OF TASK

---

## 12.35. PILOT FIRE BOTTLE SELECT SWITCH REPLACEMENT

---

### 12.35.1. Description

This task covers: Removal. Cleaning. Inspection. Installation.

---

### 12.35.2. Initial Setup

#### Tools:

Electrical tool kit (item 378, App H)

#### Personnel Required:

68X Armament/Electrical System Repairer  
 68X3F Armament/Electrical System Repairer/  
 Technical Inspector

#### References:

TM 1-1520-238-T

#### Equipment Conditions:

<u>Ref</u>	<u>Condition</u>
1.57	Helicopter safed
2.178	Nontransparent barrier removed

### 12.35.3. Removal

- a. **Enter pilot station** (para 1.56). **Observe all safety precautions.**
- b. **On pilot center circuit breaker panel, open FIRE EXTGH PLT, CPG, and APU circuit breakers.**

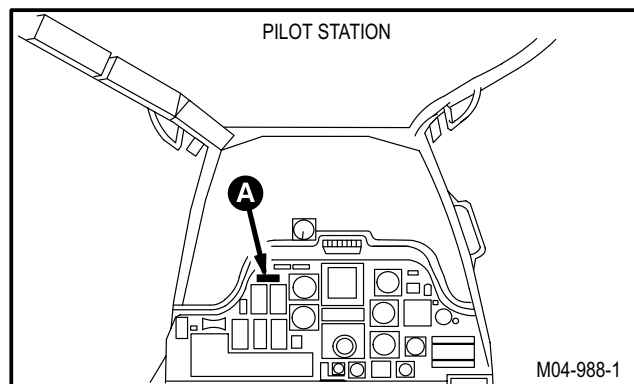

GO TO NEXT PAGE

**12.35. PILOT FIRE BOTTLE SELECT SWITCH REPLACEMENT - continued**

c. **Remove light indicating panel (1) from instrument panel (2).**

- (1) Remove two screws (3).
- (2) Remove panel (1).

d. **Remove nut (4) and lockring (5) from switch (6).**

e. **Enter CPG station (para 1.56). Observe all safety precautions.**

f. **Remove switch (6) from panel (2).**

- (1) Remove lockwasher (7) from switch (6).

g. **Detach wires (8) from switch (6).**

- (1) Identify and detach wires (8) from terminals (9).
- (2) Remove screws (10), washers (11), and terminal lugs (12).

h. **Remove and discard switch (6).**

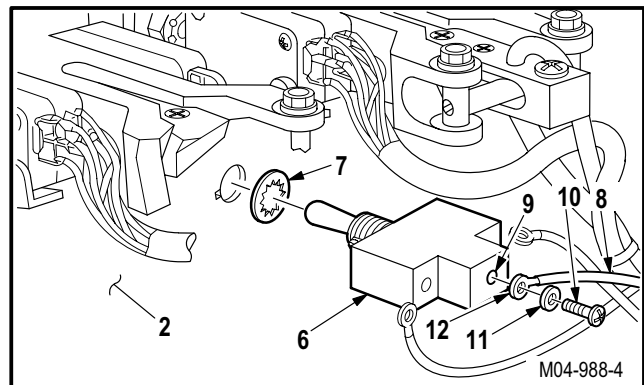
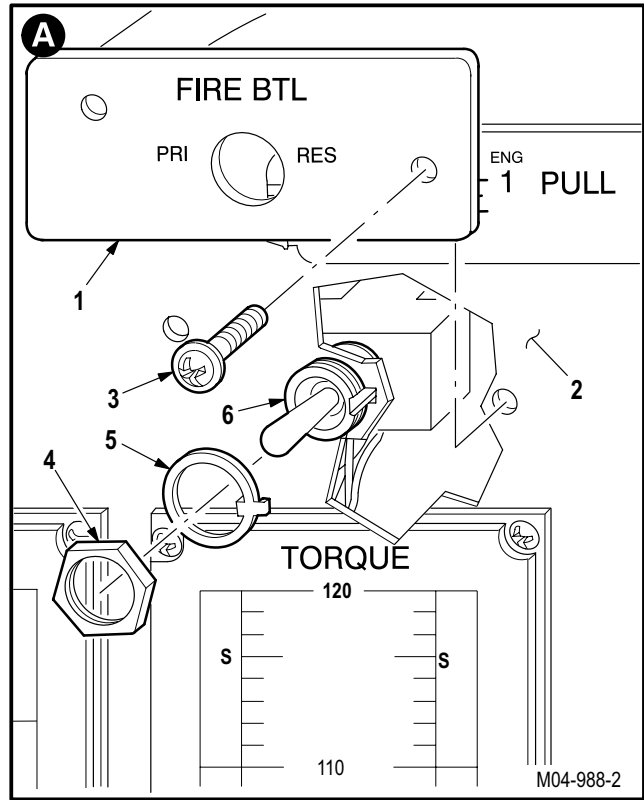

12.35.4. Cleaning

a. **Wipe removed and attaching parts with a clean rag.**

12.35.5. Inspection

- a. **Check wires for cuts, nicks, fraying, or chafing (para 12.33).**
- b. **Check removed and attaching parts for corrosion (para 1.49).**

GO TO NEXT PAGE

**12.35. PILOT FIRE BOTTLE SELECT SWITCH REPLACEMENT - continued**

12.35.6. Installation

a. **Enter CPG station** (para 1.56). **Observe all safety precautions.**

b. **Attach wires (8) to new switch (6).**

- (1) Position identified wires (8) on terminals (9).
- (2) Install screws (10), washers (11), and terminal lugs (12).

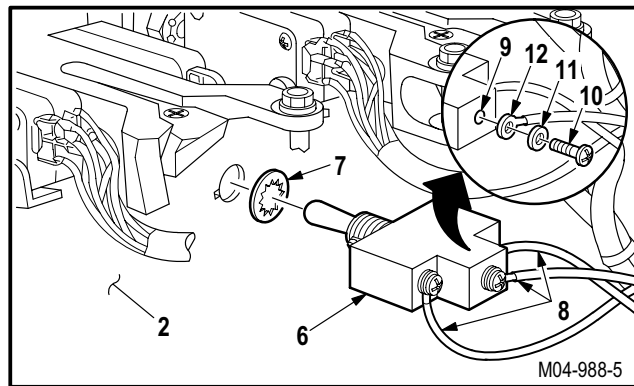

c. **Install switch (6) on panel (2).**

- (1) Install lockwasher (7) on switch (6).
- (2) Install switch (6) through panel (2).

d. **Enter pilot station** (para 1.56). **Observe all safety precautions.**

e. **Install lockring (5) and nut (4) on switch (6).**

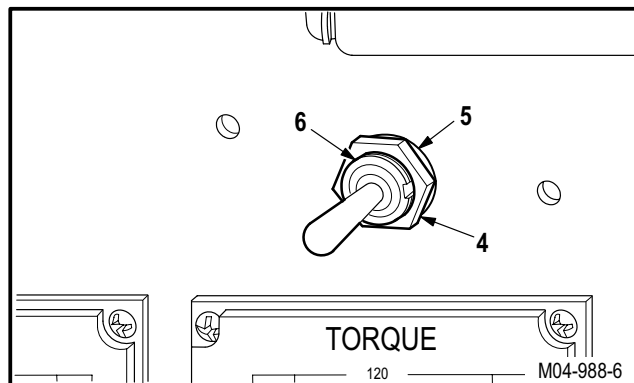

f. **Install panel (1) on panel (2).**

- (1) Position panel (1) on panel (2).
- (2) Install two screws (3).

g. **Inspect (QA).**

h. **Perform fire extinguishers maintenance operational check** (TM 1-1520-238-T).

i. **Install nontransparent barrier** (para 2.178).

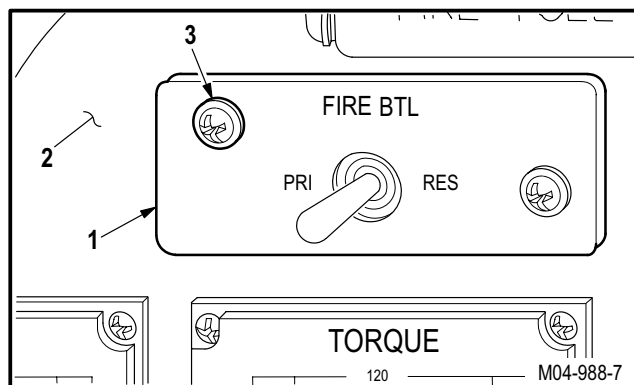

END OF TASK

**12.36. CPG ENGINE FIRE PULL SWITCH REMOVAL/INSTALLATION**

12.36.1. Description

This task covers: Removal. Cleaning. Inspection. Installation.

12.36.2. Initial Setup

**Tools:**

- Electrical tool kit (item 378, App H)
- Light duty laboratory apron (item 27, App H)
- Chemical protective gloves (item 154, App H)
- Electric gun type heater (item 163, App H)
- Adjustable air filtering respirator (item 262, App H)
- Soldering gun (item 334, App H)

**Personnel Required:**

- 68X Armament/Electrical System Repairer  
One person to assist
- 68X3F Armament/Electrical System Repairer/  
Technical Inspector

**References:**

- TM 1-1520-238-T
- TM 55-1500-323-24

**Equipment Conditions:**

<u>Ref</u>	<u>Condition</u>
1.57	Helicopter safed
12.37	CPG fire bottle select switch light indicating panel removed

**Materials/Parts:**

- Splice (2)
- Insulation sleeving (item 105, App F)
- Solder (item 189, App F)

**NOTE**

This task is typical for No. 1 or No. 2 CPG engine fire pull switch.

12.36.3. Removal

- a. **Enter pilot station (para 1.56). Observe all safety precautions.**
- b. **On pilot center circuit breaker panel, open FIRE EXTGH PLT, CPG, and APU circuit breakers.**
- c. **Enter CPG station (para 1.56). Observe all safety precautions.**

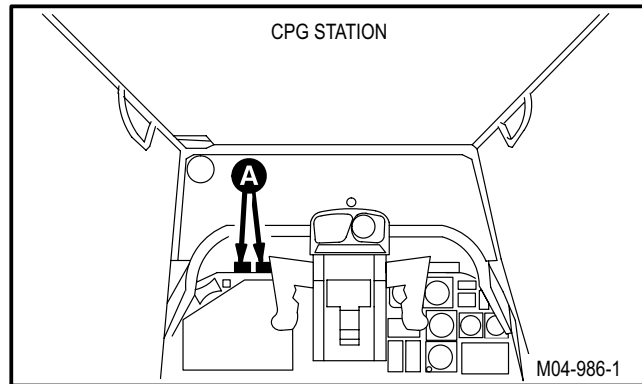

GO TO NEXT PAGE



### 12.36. CPG ENGINE FIRE PULL SWITCH REMOVAL/INSTALLATION - continued

d. **Remove access panel (1) from control panel (2).**

- (1) Remove five screws (3).
- (2) Remove panel (1).

**NOTE**

Both engine fire pull switches must be removed from control panel to allow maintenance on either switch.

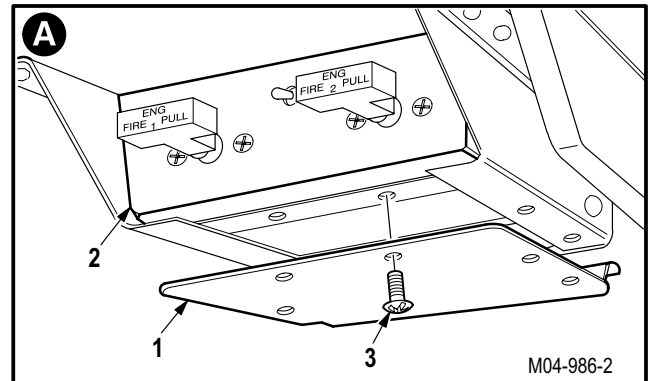

e. **Remove handle (4) from engine fire pull switch (5).**

- (1) Pull handle (4) to extended position.
- (2) Remove screw (6).
- (3) Remove handle (4).

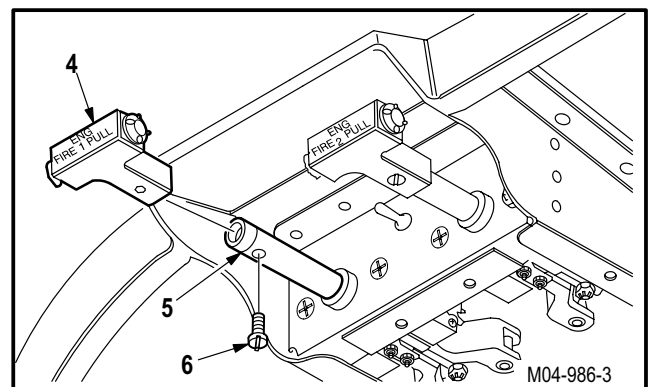

f. **Remove switch (5) from panel (2).**

- (1) Remove two screws (7).
- (2) Remove switch (5).

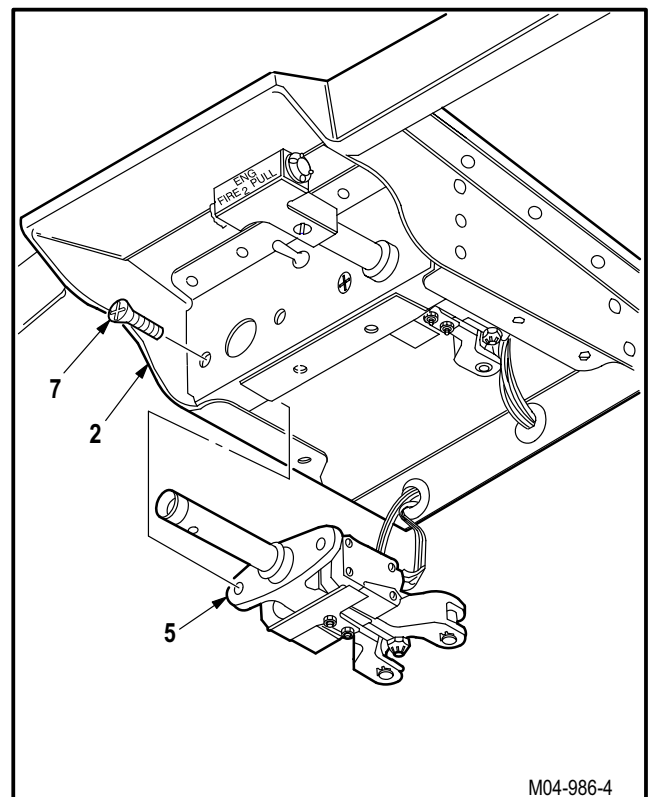

GO TO NEXT PAGE

12.36. CPG ENGINE FIRE PULL SWITCH REMOVAL/INSTALLATION - continued



**WARNING**

**Soldering gun can cause severe burns to personnel and start fires. Observe all safety precautions when using soldering gun. If injury occurs, seek medical aid.**

**g. Desolder wires (8) from switch (5).**

- (1) Remove sleeving (9) from wires (8).
- (2) Identify and desolder wires (8) from terminals (10). Use soldering gun (TM 55-1500-323-24).

**h. Identify and detach two wires (11) from wires (12).**

- (1) Remove and discard two splices (13) (TM 55-1500-323-24).

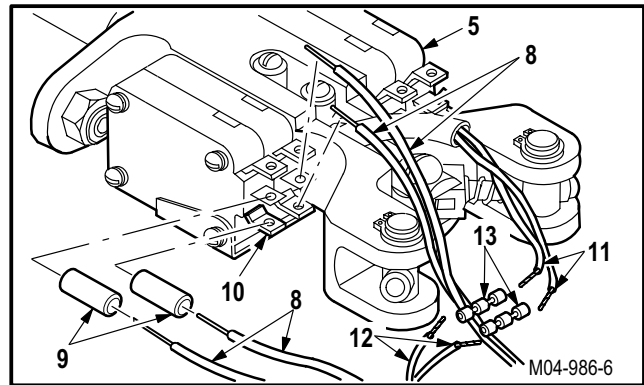

12.36.4. Cleaning

- a. **Wipe removed and attaching parts with a clean rag.**

12.36.5. Inspection

- a. **Check switches for cracks and broken or loose terminals** (para 12.33).
- b. **Check wires for cuts, nicks, fraying, or chafing** (para 12.33).
- c. **Check removed and attaching parts for corrosion** (para 1.49).

GO TO NEXT PAGE

---

**12.36. CPG ENGINE FIRE PULL SWITCH REMOVAL/INSTALLATION - continued**

---

12.36.6. Installation**NOTE**

If replacing switch, go to paragraph 12.36.3 to remove handles from new switch.

- a. **Enter CPG station** (para 1.56). **Observe all safety precautions.**



**WARNING**

- **Soldering gun can cause severe burns to personnel and start fires. Observe all safety precautions when using soldering gun. If injury occurs, seek medical aid.**
- **Do not place heater near flammable material or allow heater to contact skin: severe burns can result. Wear protective equipment. If injury occurs, seek medical aid.**

- b. **Solder wires (8) to switch (5).**

- (1) Install sleeving (9) on wires (8). Use insulation sleeving (item 105, App F).
- (2) Solder identified wires (8) to terminals (10). Use soldering gun and solder (item 189, App F) (TM 55-1500-323-24).
- (3) Position sleeving (9) on terminals (10) and shrink. Use heater.

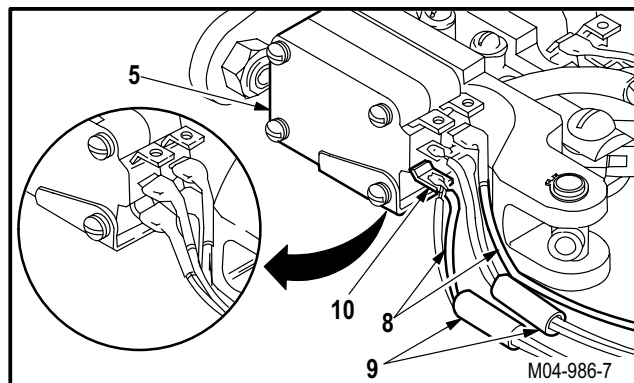

GO TO NEXT PAGE

**12.36. CPG ENGINE FIRE PULL SWITCH REMOVAL/INSTALLATION - continued**

**c. Attach two identified wires (11) to wires (12).**

- (1) Install two new splices (13) (TM 55-1500-323-24).

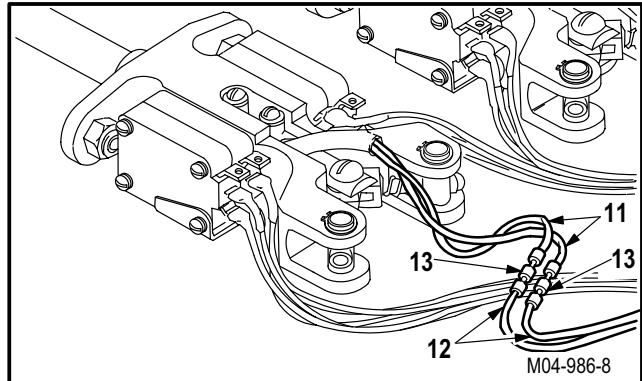

**d. Install switch (5) on panel (2).**

- (1) Position switch (5) on panel (2).
- (2) Install two screws (7).

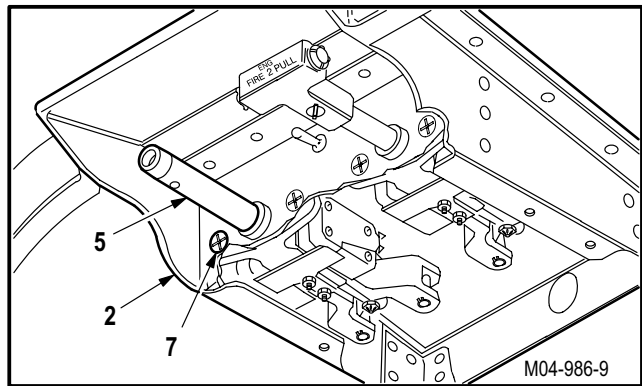

**e. Install handle (4) on switch (5).**

- (1) Install handle (4) on switch (5).
- (2) Install screw (6).
- (3) Push handle (4) to retracted position.

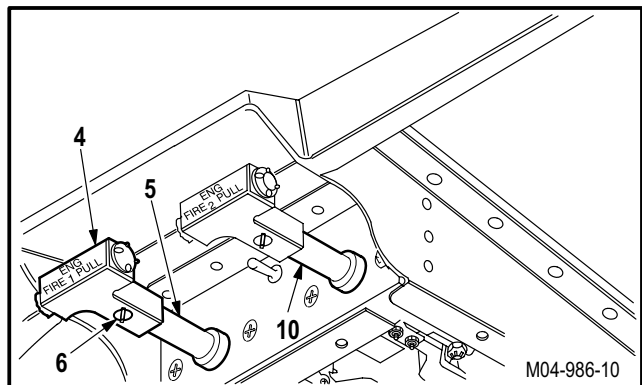

**f. Install panel (1) on panel (2).**

- (1) Install five screws (3).

**g. Inspect (QA).**

**h. Install CPG fire bottle select switch light indicating panel (para 12.37).**

**i. Perform fire extinguishers maintenance operational check (TM 1-1520-238-T).**

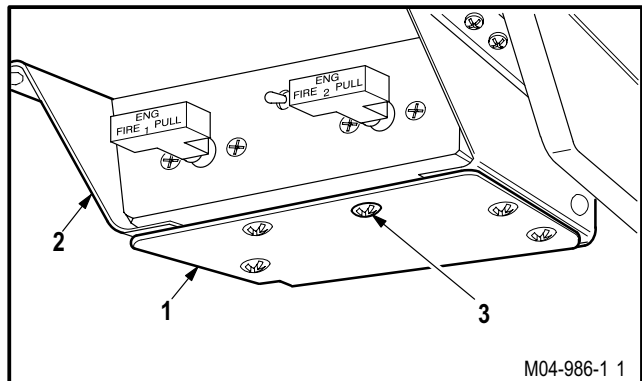

END OF TASK

## 12.37. CPG FIRE BOTTLE SELECT SWITCH REPLACEMENT

### 12.37.1. Description

This task covers: Removal. Cleaning. Inspection. Installation.

### 12.37.2. Initial Setup

#### Tools:

Electrical tool kit (item 378, App H)

#### References:

TM 1-1520-238-T

#### Personnel Required:

68X Armament/Electrical System Repairer  
 68X3F Armament/Electrical System Repairer/  
 Technical Inspector

#### Equipment Conditions:

Ref	Condition
1.57	Helicopter safed

### 12.37.3. Removal

- a. Enter pilot station (para 1.56). Observe all safety precautions.
- b. On pilot center circuit breaker panel, open FIRE EXTGH PLT, CPG, and APU circuit breakers.
- c. Enter CPG station (para 1.56). Observe all safety precautions.
- d. Remove access panel (1) from control panel (2).
  - (1) Remove five screws (3).
  - (2) Remove panel (1).

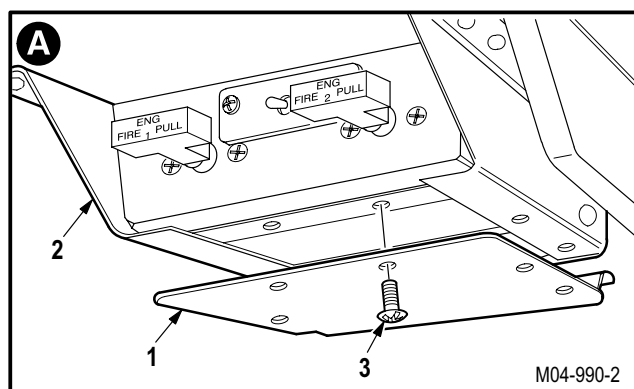
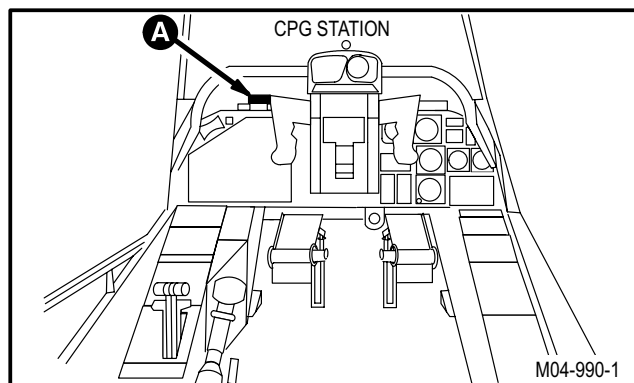

GO TO NEXT PAGE

**12.37. CPG FIRE BOTTLE SELECT SWITCH REPLACEMENT - continued**

e. **Remove light indicating panel (4) from control panel (2).**

- (1) Remove two screws (5).
- (2) Remove panel (4).

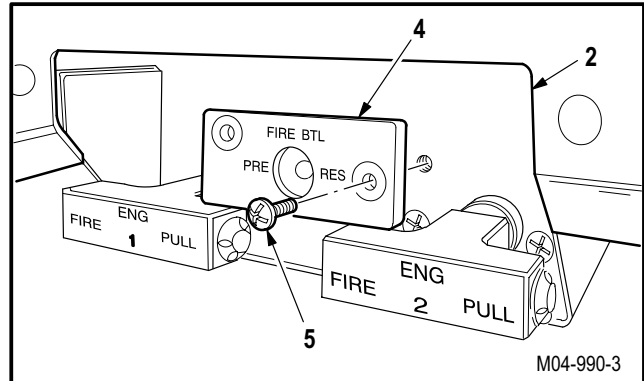

f. **Remove switch (6) from panel (2).**

- (1) Remove nut (7) and lockring (8) from switch (6).
- (2) Remove switch (6) from panel (2).

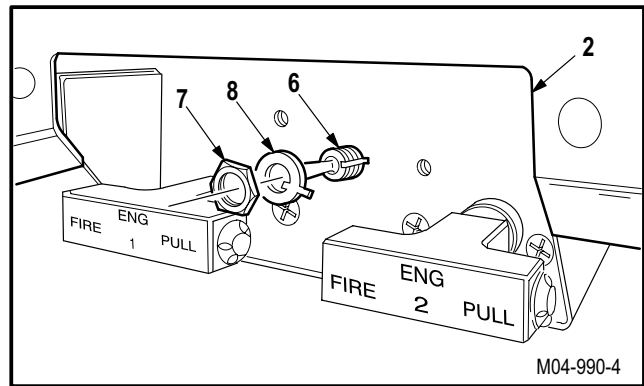

- (3) Remove lockwasher (9) from switch (6).

g. **Detach wires (10) from switch (6).**

- (1) Identify and detach wires (10) from terminals (11).
- (2) Remove screws (12), washers (13), and terminal lugs (14).

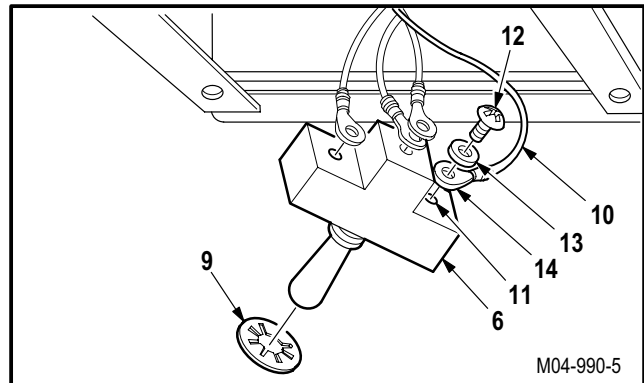

h. **Remove and discard switch (6).**

12.37.4. Cleaning

a. **Wipe removed and attaching parts with a clean rag.**

12.37.5. Inspection

- a. **Check wires for cuts, nicks, fraying, or chafing (para 12.33).**
- b. **Check removed and attaching parts for corrosion (para 1.49).**

GO TO NEXT PAGE

**12.37. CPG FIRE BOTTLE SELECT SWITCH REPLACEMENT - continued**

12.37.6. Installation

a. **Enter CPG station** (para 1.56). **Observe all safety precautions.**

b. **Attach wires (10) on new switch (6).**

- (1) Position identified wires (10) on terminals (11).
- (2) Install screws (12), washers (13), and terminal lugs (14).

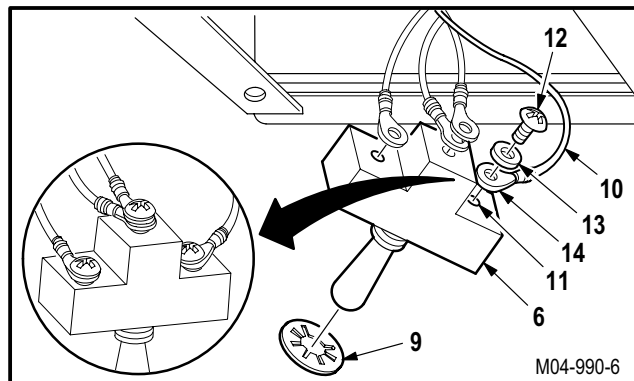

c. **Install switch (6) on panel (2).**

- (1) Install lockwasher (9) on switch (6).
- (2) Install switch (6) through control panel (2).
- (3) Install lockring (8) and nut (7) on switch (6).

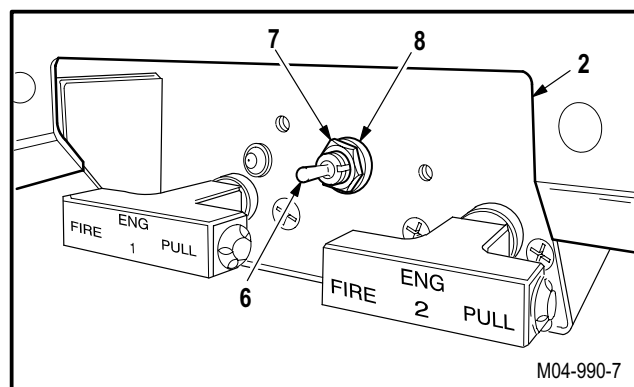

d. **Install panel (4) on panel (2).**

- (1) Position panel (4) on panel (2).
- (2) Install two screws (5).

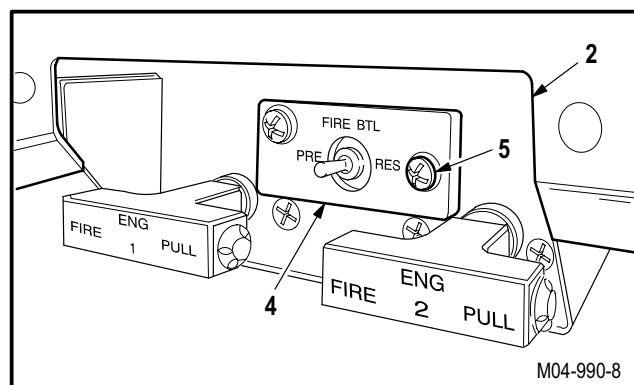

e. **Install panel (1) on panel (2).**

- (1) Position panel (1) on panel (2).
- (2) Install five screws (3).

f. **Inspect (QA).**

g. **Perform fire extinguishers maintenance operational check** (TM 1-1520-238-T).

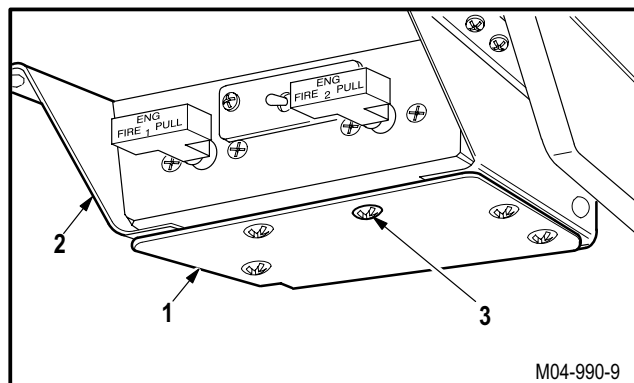

END OF TASK

**12.38. PRIMARY AND RESERVE FIRE EXTINGUISHER REMOVAL**

12.38.1. Description

This task covers: Removal. Cleaning. Inspection.

12.38.2. Initial Setup

**Tools:**

- Aircraft mechanic's tool kit (item 376, App H)
- 1 x 3/8-inch drive open end socket wrench crowfoot attachment (item 93, App H)
- 1 1/16 & 1 1/4-inch open end wrench (item 416, App H)
- 1 & 1 1/8-inch open end wrench (item 417, App H)
- Light duty laboratory apron (item 27, App H)
- Chemical protective gloves (item 154, App H)
- Industrial goggles (item 156, App H)
- Adjustable air filtering respirator (item 262, App H)

**Materials/Parts:**

- Disposable applicator (item 29A, App F)
- Cloth (item 52, App F)
- Corrosion preventive compound (item 63A, App F)
- Wire (item 226, App F)

**Personnel Required:**

- 67R Attack Helicopter Repairer
- 67R3F Attack Helicopter Repairer/Technical Inspector

**Equipment Conditions:**

<u>Ref</u>	<u>Condition</u>
1.57	Helicopter safed
2.2	Access doors T250L, T250R, T290L, T290R, and L325 opened
13.3	ENCU removed (if required)



- To avoid serious injury to personnel, cartridges must be removed before shipment or storage of fire extinguishers.
- Each actuator stud must be wired to ground stud to prevent accidental discharge of fire extinguishers. These extinguishers are filled with a dangerous chemical. All personnel must wear safety goggles when removing extinguishers. If extinguisher discharges, it can burn eyes and skin. Wash chemical off skin with water and seek medical aid.

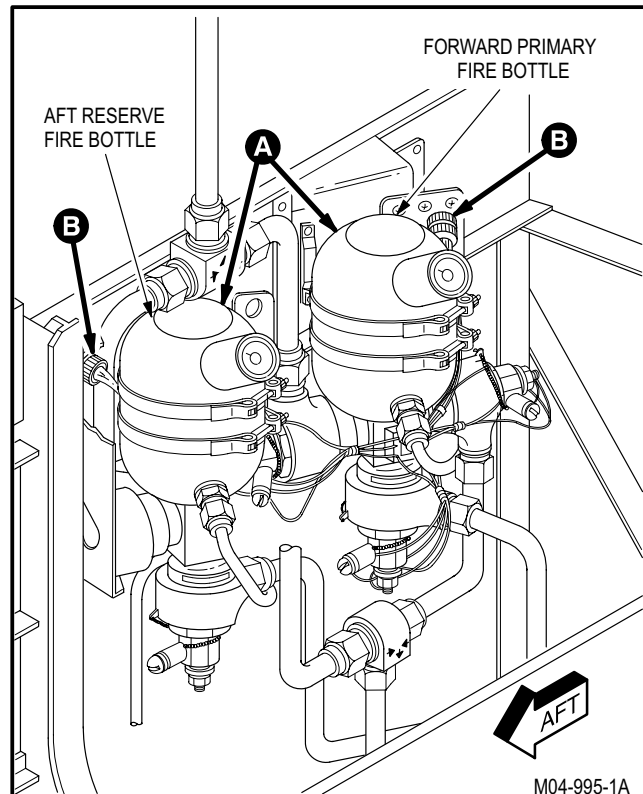

GO TO NEXT PAGE



**12.38. PRIMARY AND RESERVE FIRE EXTINGUISHER REMOVAL - continued**

**NOTE**

This task is typical for primary or reserve fire extinguishers.

12.38.3. Removal

- a. **Enter pilot station (para 1.56). Observe all safety precautions.**
- b. **On pilot center circuit breaker panel, open FIRE EXTGH PLT, CPG, and APU circuit breakers.**

c. **Install shorting wire (1) on cartridge (2).**

(1) Cut **4 INCH** length of lockwire. Use wire (item 226, App F).

(2) Wrap one end of wire around terminal (3). Wrap other end of wire around terminal (4).

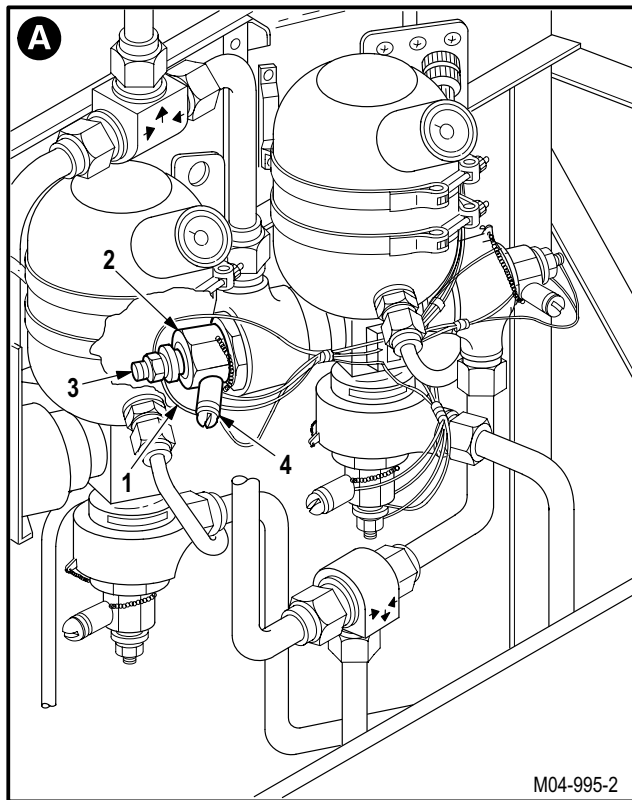

d. **Install shorting wire (5) on cartridge (6).**

(1) Cut **4 INCH** length of lockwire. Use wire (item 226, App F).

(2) Wrap one end of wire around terminal (7). Wrap other end of wire around terminal (8).

e. **Install shorting wire (9) on cartridge (10).**

(1) Cut **4 INCH** length of lockwire. Use wire (item 226, App F).

(2) Wrap one end of wire around terminal (11). Wrap other end of wire around terminal (12).

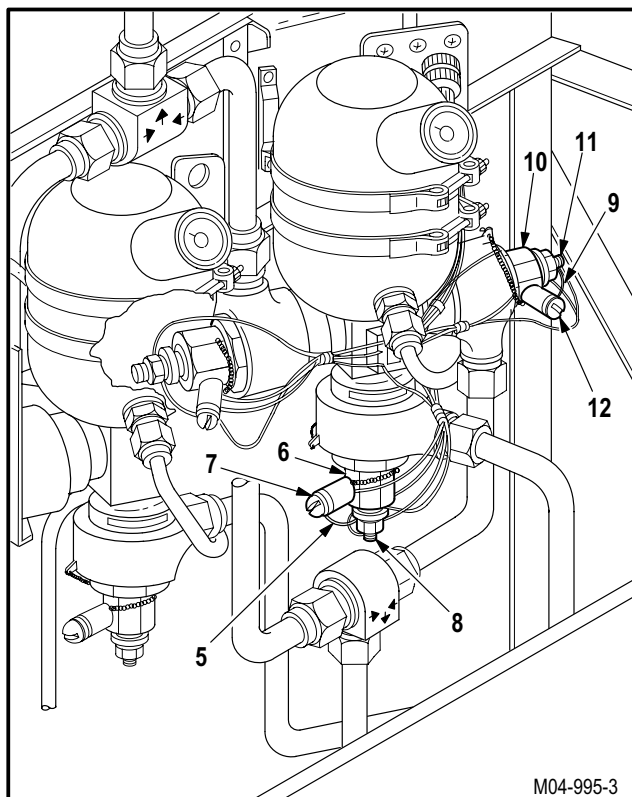

GO TO NEXT PAGE

**12.38. PRIMARY AND RESERVE FIRE EXTINGUISHER REMOVAL - continued**

- f. **Detach primary connector (E100)P1 (13) from receptacle J757 (14) and/or detach reserve connector (E100)P1 (13) from receptacle J758 (14).**

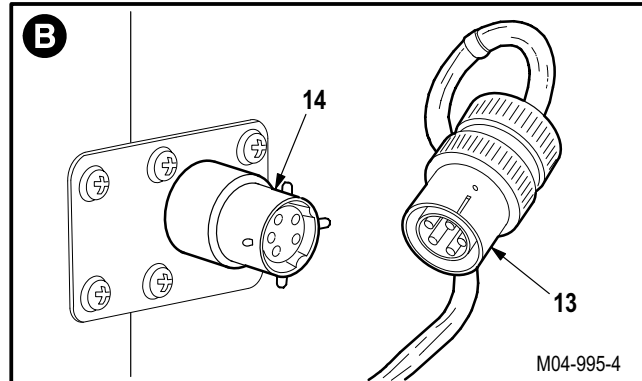

- g. **Remove tube (15) from two-way check valve (16).**

- (1) Hold check valve (16). Use open end wrench.
- (2) Remove nut (17). Use open end wrench.

- h. **Remove tube (15) from swivel (18).**

- (1) Remove nut (19). Use crowfoot.
- (2) Remove tube (15).

- i. **Remove tube (20) from two-way check valve (21).**

- (1) Hold check valve (21). Use open end wrench.
- (2) Remove nut (22). Use open end wrench.

- j. **Remove tube (20) from swivel (23).**

- (1) Remove nut (24). Use crowfoot.
- (2) Remove tube (20).

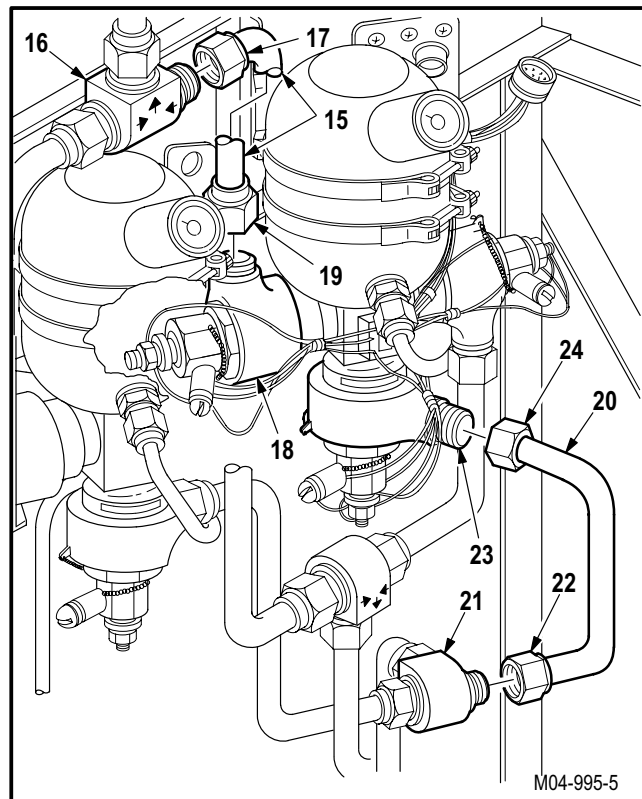

GO TO NEXT PAGE

**12.38. PRIMARY AND RESERVE FIRE EXTINGUISHER REMOVAL - continued**

**k. Remove tube (25) from two-way check valve (26).**

- (1) Hold check valve (26). Use open end wrench.
- (2) Remove nut (27). Use crowfoot.

**l. Remove tube (25) from swivel (28).**

- (1) Remove nut (29). Use crowfoot.
- (2) Remove tube (25).

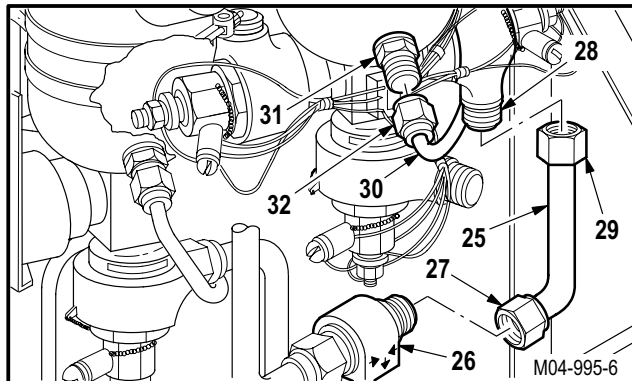

**m. Remove tube (30) from thermal relief valve (31).**

- (1) Hold relief valve (31).
- (2) Remove nut (32).

**n. Remove fire extinguisher (33) from bracket (34).**

- (1) Remove two nuts (35) from two clamps (36).
- (2) Remove extinguisher (33).
- (3) Install two nuts (35) on clamps (36).

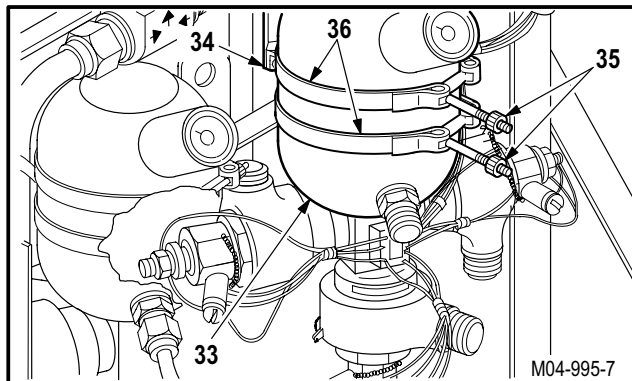

**12.38.4. Cleaning**

**a. Wipe removed and attaching parts with a clean rag.**

**b. Clean vertical outlet ports of stop check valves.**

- (1) Use a swab and water to clean vertical outlet ports. Use Disposable applicator (item 29A, App F).

**NOTE**

Use of compressed air to expedite drying time is permitted.

- (2) Allow to air dry.

GO TO NEXT PAGE

---

12.38. PRIMARY AND RESERVE FIRE EXTINGUISHER REMOVAL - continued

---



(3) Apply corrosion preventive compound to inside of vertical outlet ports. Use corrosion preventive compound (item 63A, App F).

(4) Allow to air dry.

(5) Wipe with a clean cloth. Use cloth (item 52, App F).

12.38.5. Inspection

- a. **Check fire extinguisher mounting brackets and clamps for cracks** (para 12.33).
- b. **Check removed and attaching parts for corrosion** (para 1.49).
- c. **Check fire extinguisher tubes for cracks, dents, nicks, chafing, wear and corrosion** (para 12.33).

END OF TASK



## 12.39. PRIMARY AND RESERVE FIRE EXTINGUISHER INSTALLATION

### 12.39.1. Description

This task covers: Installation.

### 12.39.2. Initial Setup

#### Tools:

- Aircraft mechanic's tool kit (item 376, App H)
- 1 x 3/8-inch drive open end socket wrench crowfoot attachment (item 93, App H)
- 0.0 - 10.0-pound weighing scale (item 272, App H)
- 15-inch adjustable wrench (item 406, App H)
- 1 1/16 & 1 1/4-inch open end wrench (item 416, App H)
- 1 & 1 1/8-inch open end wrench (item 417, App H)
- 30 - 150 inch-pound 1/4-inch drive click type torque wrench (item 435, App H)

#### References:

TM 1-1520-238-T

#### Personnel Required:

- 67R Attack Helicopter Repairer
- 67R3F Attack Helicopter Repairer/Technical Inspector

#### Equipment Conditions:

<u>Ref</u>	<u>Condition</u>
1.57	Helicopter safed



Each actuator stud must be wired to ground stud to prevent accidental discharge of fire extinguishers. These extinguishers are filled with a dangerous chemical. All personnel must wear safety goggles when installing extinguishers. If extinguisher discharges, it can burn eyes and skin. Wash chemical off skin with water and seek medical aid.

#### NOTE

This task is typical for primary or reserve fire extinguishers.

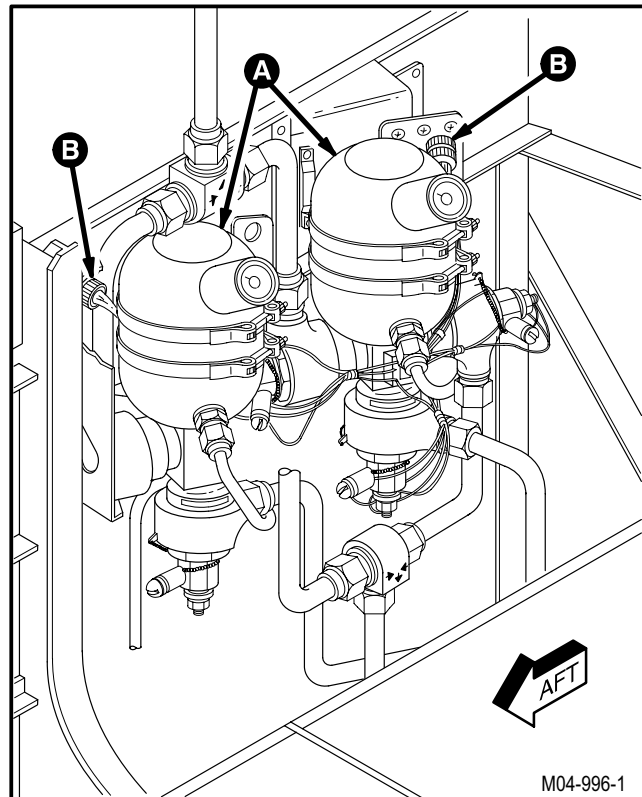

GO TO NEXT PAGE

**12.39. PRIMARY AND RESERVE FIRE EXTINGUISHER INSTALLATION - continued**

**a. Weigh fire extinguisher.**

- (1) Weight should be **5.93 to 6.03 POUNDS**. Use scale.
- (2) If weight is not within limits, replace fire extinguisher.

**b. Install fire extinguisher (1) on bracket (2). Torque two nuts (3) to 50 INCH-POUNDS.**

- (1) Position extinguisher (1) on bracket (2).
- (2) Install two nuts (3) on two clamps (4).
- (3) Torque two nuts (3) to **50 INCH-POUNDS**. Use torque wrench.

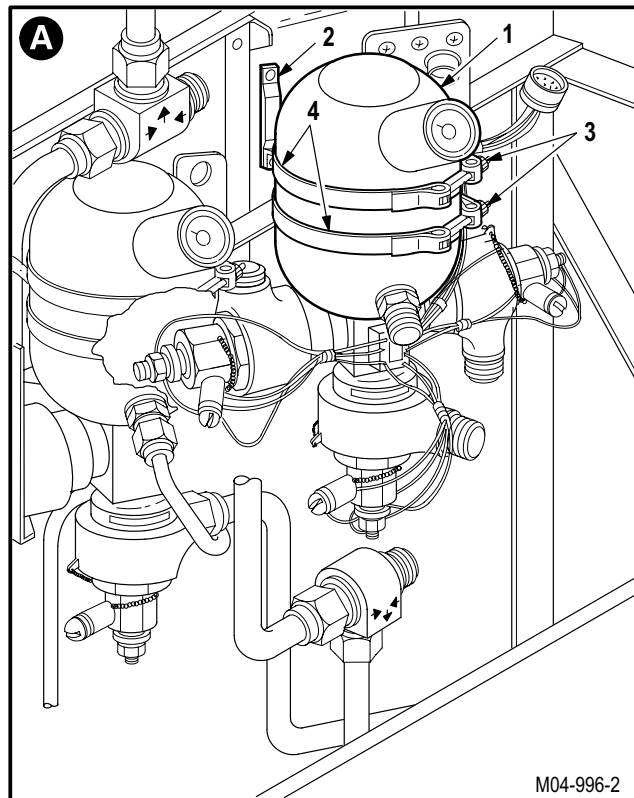

**c. Install tube (5) on thermal relief valve (6).**

- (1) Hold relief valve (6). Install nut (7).

**d. Install tube (8) on swivel (9).**

- (1) Hold swivel (9). Use adjustable wrench.
- (2) Install nut (10). Use crowfoot.

**e. Install tube (8) on two-way check valve (11).**

- (1) Hold check valve (11). Use open end wrench.
- (2) Install nut (12). Use crowfoot.

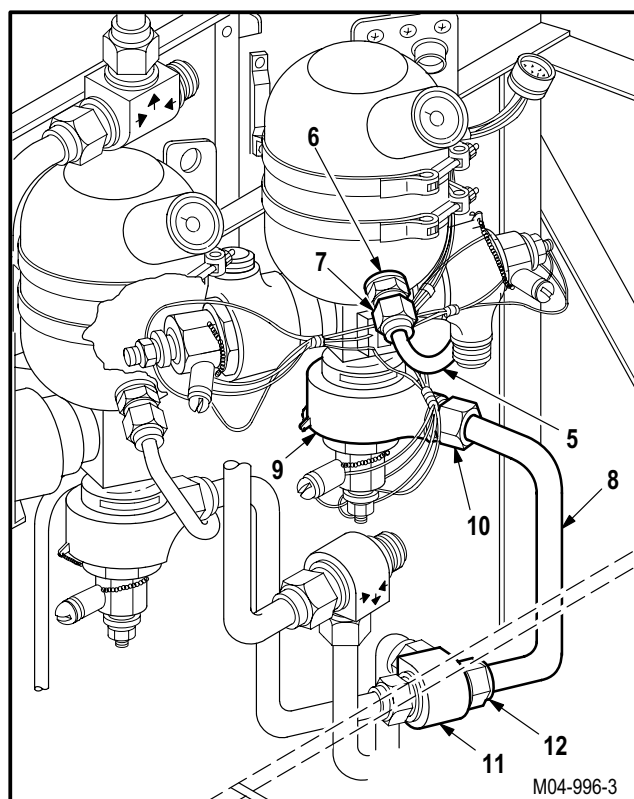

GO TO NEXT PAGE

**12.39. PRIMARY AND RESERVE FIRE EXTINGUISHER INSTALLATION - continued**

**f. Install tube (13) on two-way check valve (14).**

- (1) Hold check valve (14). Use open end wrench.
- (2) Install nut (15). Use crowfoot.

**g. Install tube (13) on swivel (16).**

- (1) Hold swivel (16). Use adjustable wrench.
- (2) Install nut (17). Use crowfoot.

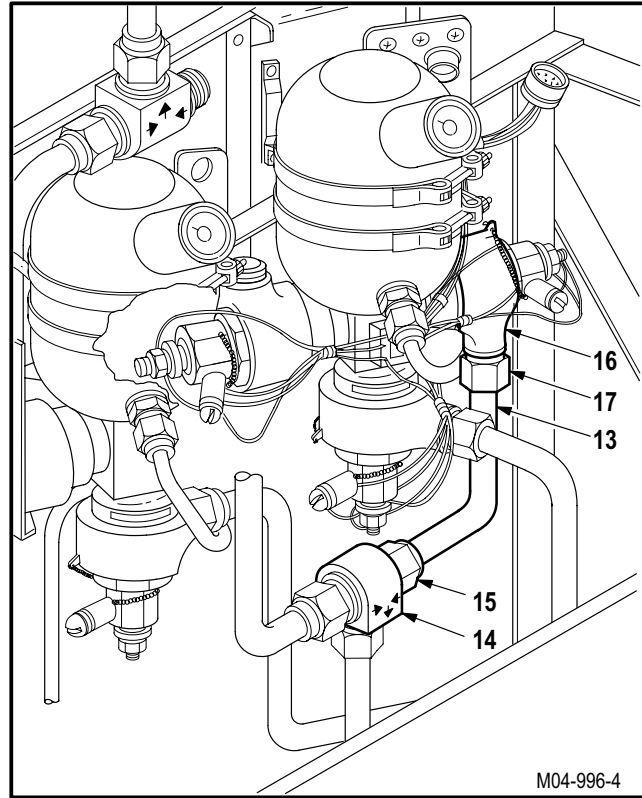

**h. Install tube (18) on two-way check valve (19).**

- (1) Hold check valve (19). Use open end wrench.
- (2) Install nut (20). Use open end wrench.

**i. Install tube (18) on swivel (21).**

- (1) Hold swivel (21). Use adjustable wrench.
- (2) Install nut (22). Use crowfoot.

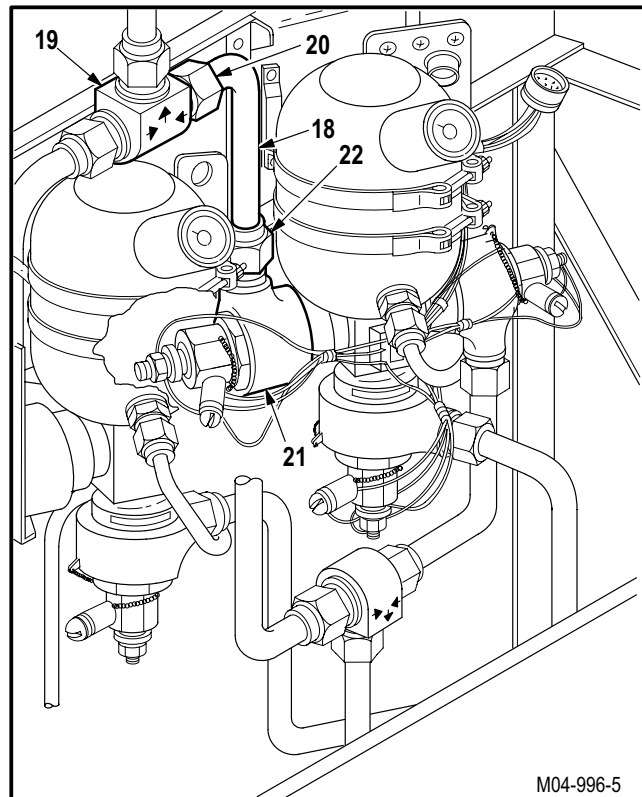

GO TO NEXT PAGE



12.39. PRIMARY AND RESERVE FIRE EXTINGUISHER INSTALLATION - continued

- j. Attach primary connector (E100)P1 (23) to receptacle J757 (24) and/or attach reserve connector (E100)P1 (23) to receptacle J758 (24).

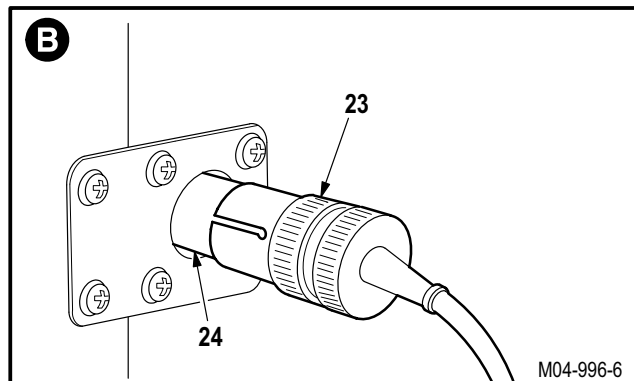

- k. Remove shorting wire (25) from terminals (26) and (27).

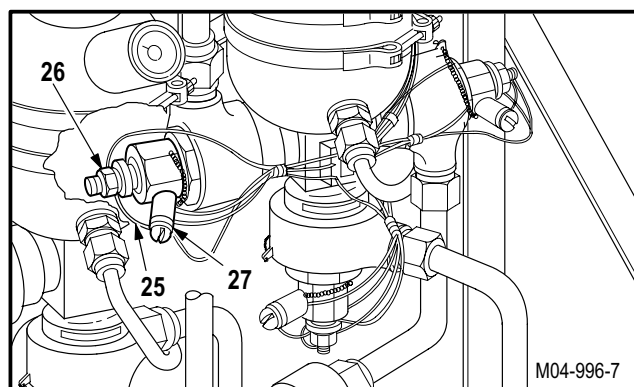

- l. Remove shorting wire (28) from terminals (29) and (30).

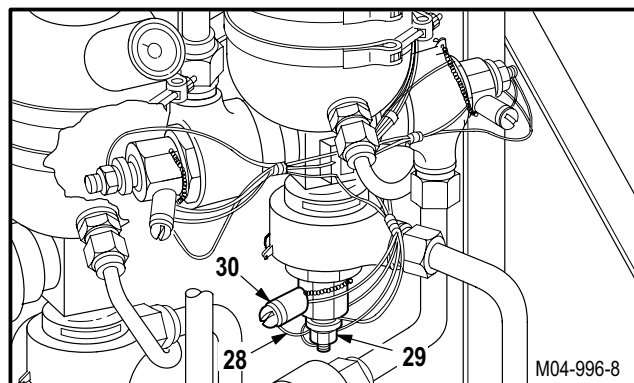

- m. Remove shorting wire (31) from terminals (32) and (33).

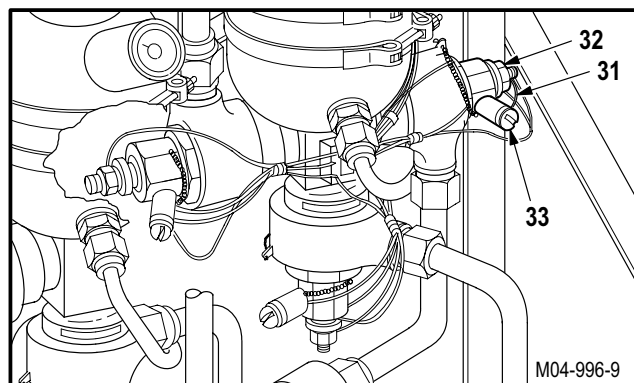

- n. Inspect (QA).

- o. Perform fire extinguishers maintenance operational check (TM 1-1520-238-T).

- p. Install ENCU, if removed (para 13.3).

**CAUTION**

Ensure there is no chafing between the ENCU and the fire extinguisher tubing (para 12.33). Failure to do so could cause a malfunction of the ECS or fire extinguishing systems.

- q. Secure access doors T250L, T250R, T290L, T290R, and L325 (para 2.2).

END OF TASK

## 12.40. FIRE EXTINGUISHER CARTRIDGE REMOVAL/INSTALLATION

### 12.40.1. Description

This task covers: Removal. Cleaning. Inspection. Installation.

### 12.40.2. Initial Setup

#### Tools:

Aircraft mechanic's tool kit (item 376, App H)  
 Light duty laboratory apron (item 27, App H)  
 15/16 x 3/8-inch drive open end box socket wrench  
 crowfoot attachment (item 80, App H)  
 Industrial faceshield (item 129, App H)  
 Chemical protective gloves (item 154, App H)  
 1 1/16 & 1 1/4-inch open end wrench (item 416, App H)  
 30 - 150 inch-pound 3/8-inch drive click type torque  
 wrench (item 441, App H)

#### Materials/Parts:

Packing  
 Petrolatum (item 138, App F)  
 Wire (item 226, App F)

#### Personnel Required:

67R Attack Helicopter Repairer  
 67R3F Attack Helicopter Repairer/Technical  
 Inspector

#### Equipment Conditions:

<u>Ref</u>	<u>Condition</u>
1.57	Helicopter safed
12.38	Primary and/or reserve fire extinguisher removed

### NOTE

This task is typical for engine No. 1, engine No. 2, and APU fire extinguisher cartridges.



- Each actuator stud must be wired to ground stud to prevent accidental explosion of cartridge. All personnel must wear safety goggles when removing and installing cartridges. Accidental explosion could cause injury to personnel. If injury occurs, seek medical aid.
- Do not loosen sensor housing or container. Container could discharge and injure personnel. If injury occurs, seek medical aid.

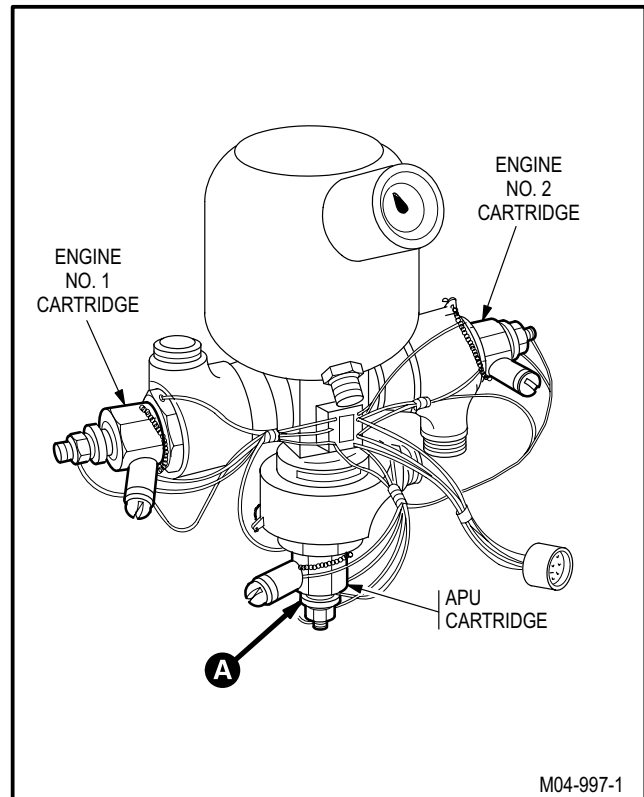

GO TO NEXT PAGE

**12.40. FIRE EXTINGUISHER CARTRIDGE REMOVAL/INSTALLATION - continued**

12.40.3. Removal

**a. Remove wire (1) from ground stud (2).**

- (1) Identify wire (1) attached to ground stud (2).
- (2) Remove shorting wire (3) from stud (2).
- (3) Remove screw (4) and washer (5).
- (4) Remove wire (1) from stud (2).

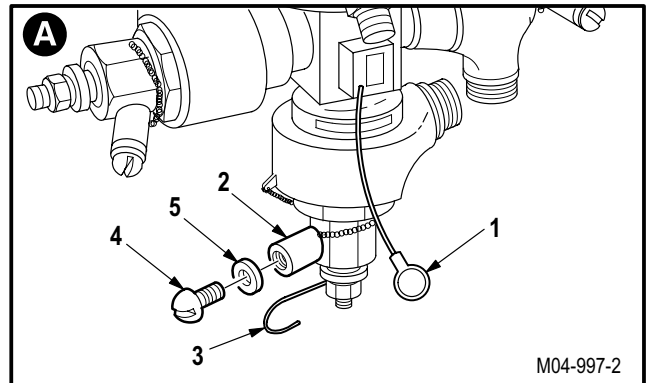

**b. Install shorting wire (3) on stud (2).**

- (1) Install screw (4), washer (5), and wire (3) on stud (2).

**c. Remove wire (6) from actuation terminal (7).**

- (1) Identify wire (6) attached to actuation terminal (7).
- (2) Remove shorting wire (3) from terminal (7).
- (3) Remove nut (8) and wire (6) from terminal (7).

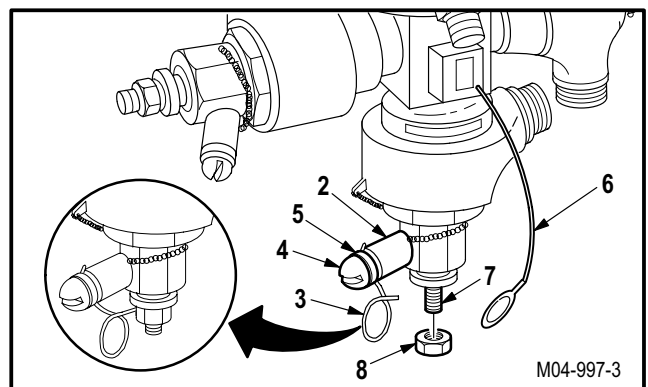

**d. Install shorting wire (3) on terminal (7).**

- (1) Wrap end of shorting wire (3) around terminal (7).
- (2) Install nut (8) on terminal (7).

GO TO NEXT PAGE

**12.40. FIRE EXTINGUISHER CARTRIDGE REMOVAL/INSTALLATION - continued**

**CAUTION**

Damage to sensor housing wires may occur if wrench is not fitted properly on wrench flats.

**e. Remove cartridge (9) from sensor housing (10).**

- (1) Remove lockwire from cartridge (9) and sensor housing (10).
- (2) Hold sensor housing (10). Use open end wrench.
- (3) Remove cartridge (9), and shim(s) (9.1) (if installed).
- (4) Remove and discard packing (11).

**12.40.4. Cleaning**

- a. **Wipe removed and attaching parts with a clean rag.**

**12.40.5. Inspection**

- a. **Check cartridge for nicks, scratches, or cracks** (para 12.33).
- b. **Check terminals and cartridge for stripped or damaged threads** (para 12.33).
- c. **Check removed and attaching parts for corrosion** (para 1.49).

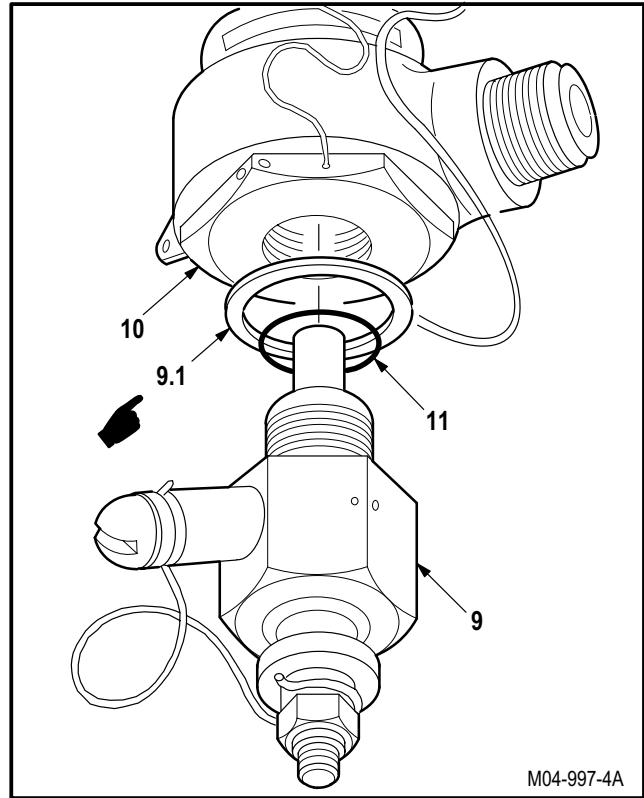

M04-997-4A

GO TO NEXT PAGE

**12.40. FIRE EXTINGUISHER CARTRIDGE REMOVAL/INSTALLATION - continued**

12.40.6. Installation

a. **Install shorting wire (3) on cartridge (9), if not installed, before handling.**

- (1) Cut a **4 INCH** length of lockwire. Use wire (item 226, App F).
- (2) Wrap one end of wire (3) around screw (4).
- (3) Wrap other end of wire (3) around terminal (7).

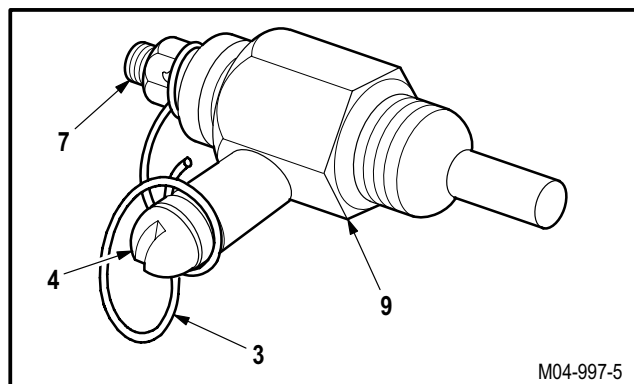

**CAUTION**

Damage to sensor housing wires may occur if wrench is not fitted properly on wrench flats.

b. **Install cartridge (9) on sensor housing (10).**  
Torque cartridge (9) to **100 INCH-POUNDS**.

- (1) Lubricate new packing (11). Use petrolatum (item 138, App F).
- (2) Install packing (11) on cartridge (9).
- (3) Install shim(s) (9.1) (if removed).
- (4) Install cartridge (9) on sensor housing (10).
- (5) Hold sensor housing (10). Use open end wrench.
- (6) Torque cartridge (9) to **100 INCH-POUNDS**. Use crowfoot and torque wrench.

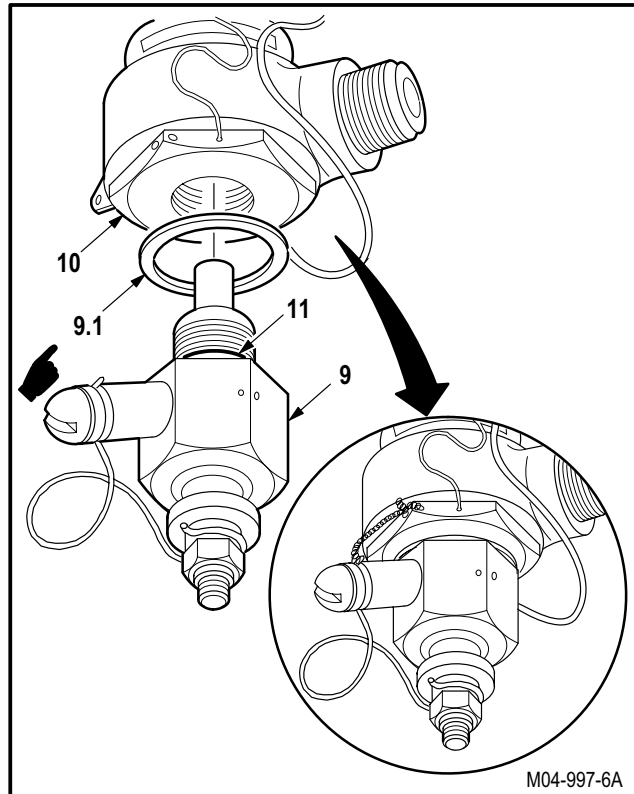

GO TO NEXT PAGE

12.40. FIRE EXTINGUISHER CARTRIDGE REMOVAL/INSTALLATION - continued

- c. Ensure the stud is free of obstructions. If stud is not free of obstructions, remove the cartridge and add or remove shims as necessary to ensure stud is free of obstructions.

**NOTE**

A maximum of three shims (if required) are allowed under cartridge to ensure position of ground stud.

- d. Deleted.
- e. Deleted.

- f. Deleted.

- g. Lockwire cartridge (9) to housing (10). Use wire (item 226, App F).

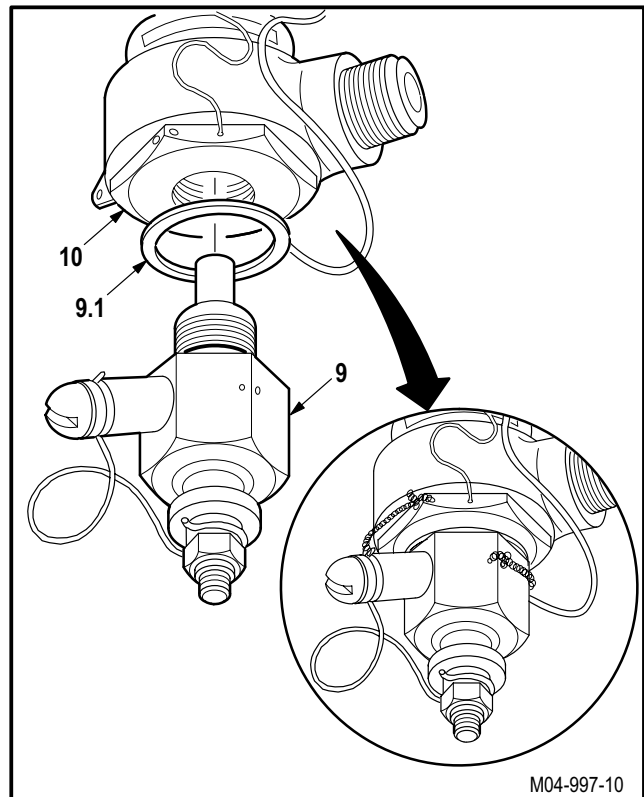
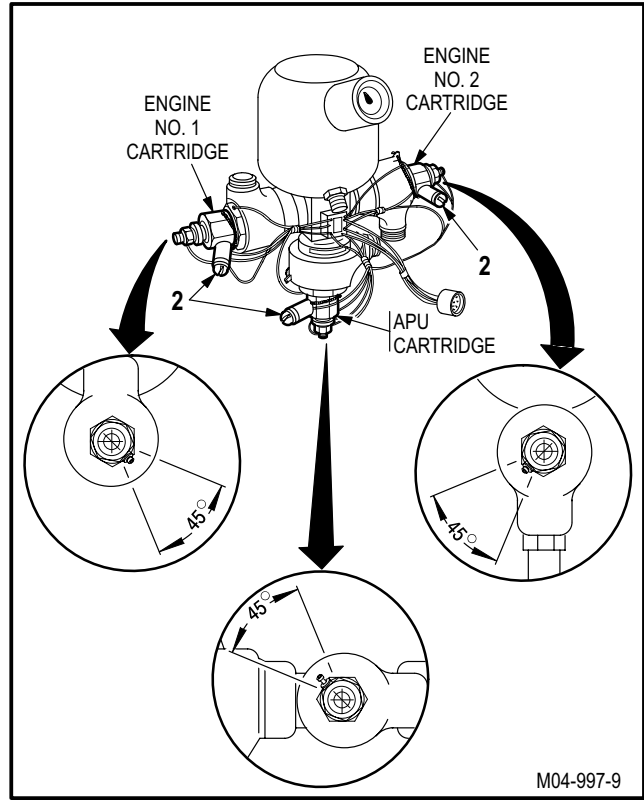

GO TO NEXT PAGE

---

**12.40. FIRE EXTINGUISHER CARTRIDGE REMOVAL/INSTALLATION - continued**



---

**NOTE**

Some cartridges are fitted with two sizes of terminals: the ground terminal with a no. 8 stud and the actuation terminal with a no. 6 stud. In this case the actuation wire lug should be replaced with a no. 6 wire lug. If both studs are the same size, attach wires as removed.

**h. Install wire (1) on ground stud (2).**

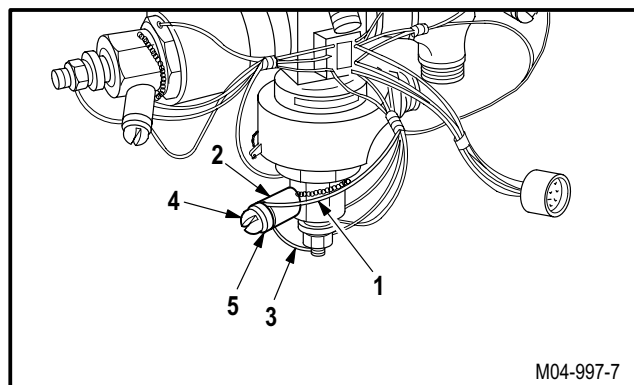
- (1) Remove screw (4), washer (5), and shorting wire (3) from stud (2).
- (2) Install screw (4), washer (5), and wire (1) on stud (2).
- (3) Wrap shorting wire (3) around screw (4).

**i. Install wire (6) on actuation terminal (7).**

- (1) Remove nut (8) from terminal (7).
- (2) Remove shorting wire (5) from terminal (7).
- (3) Install wire (6) on terminal (7).
- (4) Install nut (8) on terminal (7).
- (5) Wrap shorting wire (1) around terminal (7).

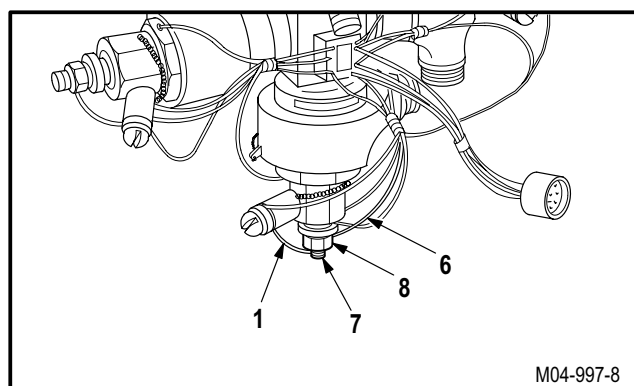
**j. Inspect (QA).****k. Install primary and/or reserve fire extinguisher (para 12.39).**

END OF TASK





---

## 12.41. FIRE EXTINGUISHER ELECTRONIC MODULE REPLACEMENT

---

### 12.41.1. Description

This task covers: Removal. Cleaning. Inspection. Installation.

---

### 12.41.2. Initial Setup

#### Tools:

Aircraft mechanic's tool kit (item 376, App H)  
 Light duty laboratory apron (item 27, App H)  
 Chemical protective gloves (item 154, App H)  
 Adjustable air filtering respirator (item 262, App H)

#### Materials/Parts:

Adhesive (item 3, App F)

#### Personnel Required:

67R Attack Helicopter Repairer  
 67R3F Attack Helicopter Repairer/Technical Inspector

#### References:

TM 55-1500-323-24

#### Equipment Conditions:

<u>Ref</u>	<u>Condition</u>
1.57	Helicopter safed
12.38	Primary and/or reserve fire extinguisher removed

### NOTE

This task is typical for primary or reserve fire extinguishers.

### 12.41.3. Removal

- a. **Identify and depin wires (1) from electronic module (2)** (TM 55-1500-323-24).
- b. **Remove and discard module (2) from fire extinguisher (3).**

### 12.41.4. Cleaning

- a. **Clean adhesive from fire extinguisher** (para 1.47).

### 12.41.5. Inspection

- a. **Check removed and attaching parts for corrosion** (para 1.49).

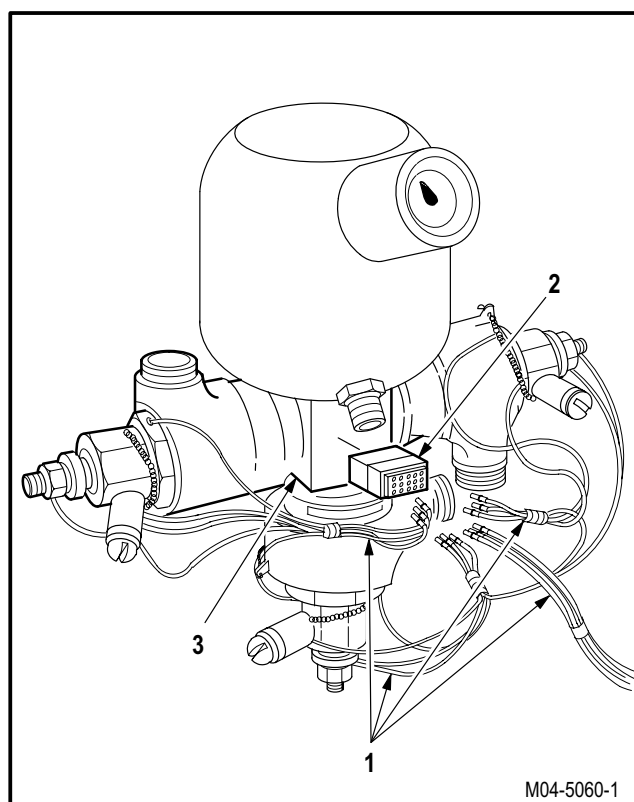

GO TO NEXT PAGE

---

**12.41. FIRE EXTINGUISHER ELECTRONIC MODULE REPLACEMENT - continued**

---

12.41.6. Installation



**a. Install module (2) on fire extinguisher (3).**

- (1) Apply adhesive to module (2) and fire extinguisher (3). Use adhesive (item 3, App F).
- (2) Position module (2) on fire extinguisher (3).
- (3) Clean excess adhesive from fire extinguisher (3).
- (4) Allow adhesive to dry **24 HOURS** at ambient temperature.

**b. Pin identified wires (1) in module (2) (TM 55-1500-323-24).**

**c. Inspect (QA).**

**d. Install primary and/or reserve fire extinguisher (para 12.39).**

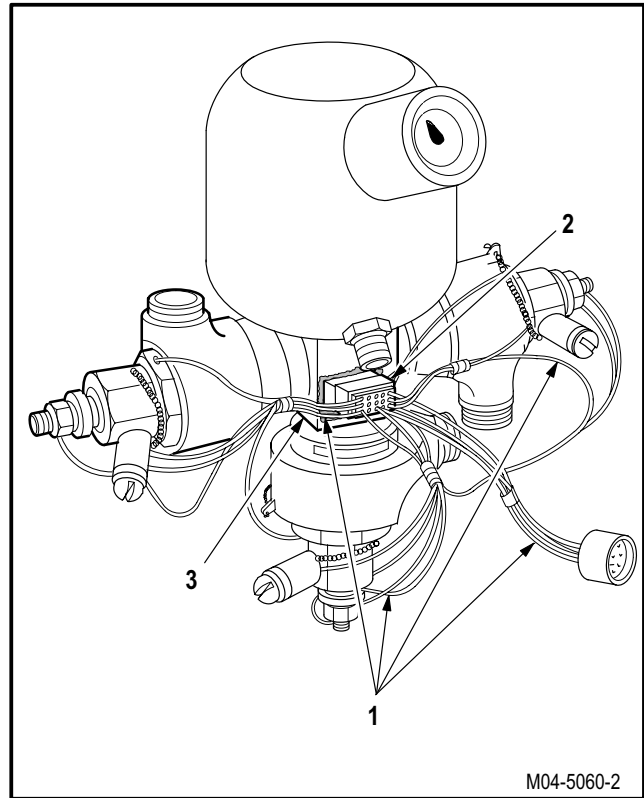

END OF TASK

**12.42. FIRE EXTINGUISHER STOP CHECK VALVE REPLACEMENT**

12.42.1. Description

This task covers: Removal. Cleaning. Inspection. Installation.

12.42.2. Initial Setup

**Tools:**

- Aircraft mechanic's tool kit (item 376, App H)
- 1 1/16 & 1 1/4-inch open end wrench (item 416, App H)
- 1 & 1 1/8-inch open end wrench (item 417, App H)
- Light duty laboratory apron (item 27, App H)
- Chemical protective gloves (item 154, App H)
- Industrial goggles (item 156, App H)
- Adjustable air filtering respirator (item 262, App H)

**Materials/Parts:**

- Brush (item 36, App F)
- Cloth (item 52, App F)
- Corrosion preventive compound (item 63A, App F)
- Corrosion removing compound (item 64B, App F)

**Personnel Required:**

- 67R Attack Helicopter Repairer
- 67R3F Attack Helicopter Repairer/Technical Inspector

**References:**

TM 1-1520-238-T

**Equipment Conditions:**

<u>Ref</u>	<u>Condition</u>
1.57	Helicopter safed
2.2	Access doors T250L, T250R, T290L, T290R, and L325 opened
13.17	Air duct No. 1 removed (if required)

**NOTE**

This task is typical for No. 1 engine, No. 2 engine, or APU fire extinguishing stop check valves.

12.42.3. Removal

- a. **Enter pilot station (para 1.56). Observe all safety precautions.**
- b. **On pilot center circuit breaker panel, open FIRE EXTGH PLT, CPG, and APU circuit breakers.**

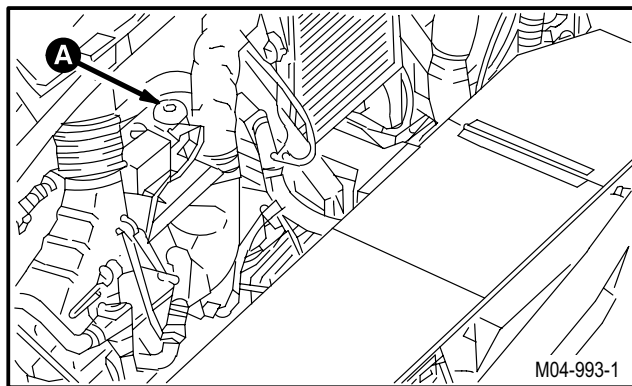

GO TO NEXT PAGE

12.42. FIRE EXTINGUISHER STOP CHECK VALVE REPLACEMENT - continued

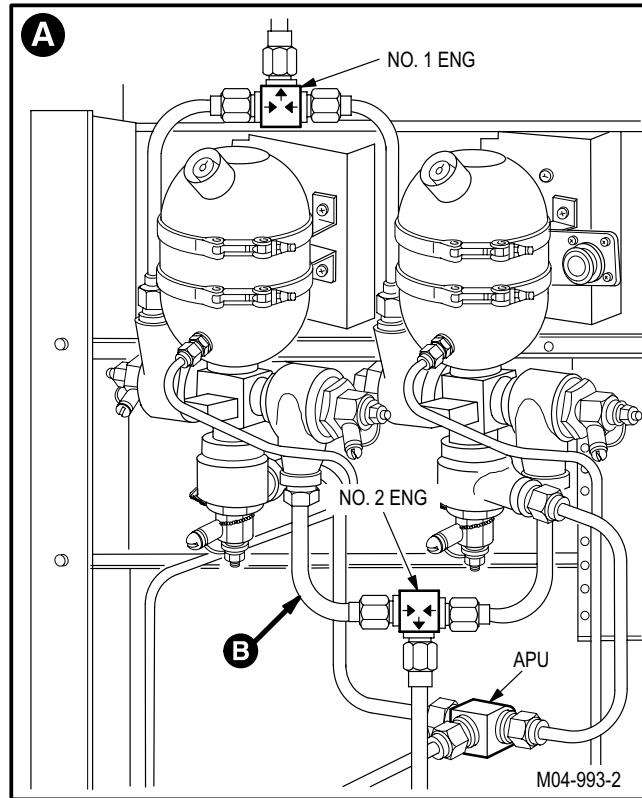

c. Remove tube (1) from check valve (2).

- (1) Hold check valve (2). Use open end wrench.
- (2) Remove nut (3). Use open end wrench.

d. Remove tube (1) from swivel (4).

- (1) Remove nut (5). Use open end wrench.
- (2) Remove tube (1).

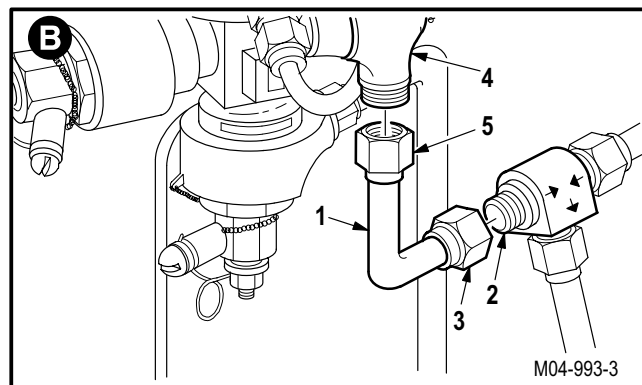

e. Remove tubes (6) and (7) from check valve (2).

- (1) Hold check valve (2). Use open end wrench.
- (2) Remove nuts (8) and (9). Use open end wrench.
- (3) Remove and discard check valve (2).

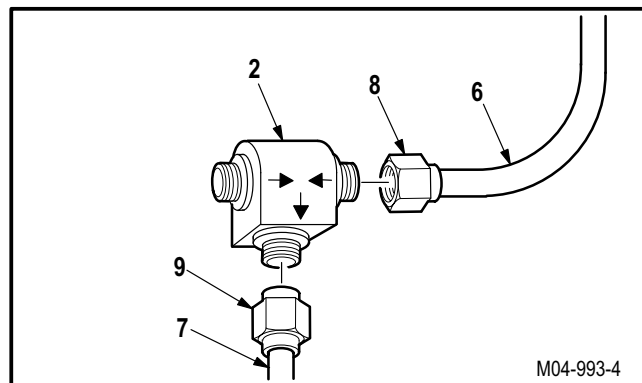

GO TO NEXT PAGE

---

## 12.42. FIRE EXTINGUISHER STOP CHECK VALVE REPLACEMENT

---

### 12.42.4. Cleaning

- a. **Wipe removed and attaching parts with a clean rag.**



- b. **Clean fire extinguisher stop check valves.**

- (1) Submerge the two way check valve in acetone long enough to remove any old corrosion preventive compound. If required, use a soft brush to remove any corrosion preventive compound.
- (2) Agitate valve while still submerged in fluid to help remove corrosion or residue of evaporation.
- (3) If required use a soft brush to help remove corrosion or evidence of evaporation. Use brush (item 36, App F).
- (4) Flush valve with clean water.

#### NOTE

Use of compressed air to expedite drying time is permitted.

- (5) Allow to air dry for 20 minutes.
- (6) Inspect (QA).
- (7) Apply corrosion preventive compound. Use corrosion preventive compound (item 63A, App F).
  - (a) Cap one end of the valve and fill with corrosion preventive compound. Use corrosion preventive compound (item 63A, App F).
  - (b) Rotate valve to insure interior surfaces are coated.
  - (c) Cap other ports and rotate to insure all interior surfaces are coated.
  - (d) Remove caps and drain excess corrosion preventive compound.
  - (e) Allow to air dry for a minimum of 20 minutes.
- (8) Wipe exterior with a clean cloth. Use cloth (item 52, App F).

### 12.42.5. Inspection

- a. **Check valve and nuts for stripped or damaged threads** (para 12.33).
- b. **Check removed and attaching parts for corrosion** (para 1.49).

GO TO NEXT PAGE

**12.42. FIRE EXTINGUISHER STOP CHECK VALVE REPLACEMENT - continued**

12.42.6. Installation

**a. Install new check valve (2) on tubes (6) and (7).**

- (1) Hold check valve (2). Use open end wrench.
- (2) Install nut (8) and (9). Use open end wrench.

**b. Install tube (1) on check valve (2) and swivel (4).**

- (1) Hold check valve (2). Use open end wrench.
- (2) Install nut (3) on check valve (2). Use open end wrench.
- (3) Install nut (5) on swivel (4). Use open end wrench.

**c. Inspect (QA).**

**d. If removed, install air duct No. 1 (para 13.17).**

**e. Secure access doors T250L, T250R, T290L, T290R, and L325 (para 2.2).**

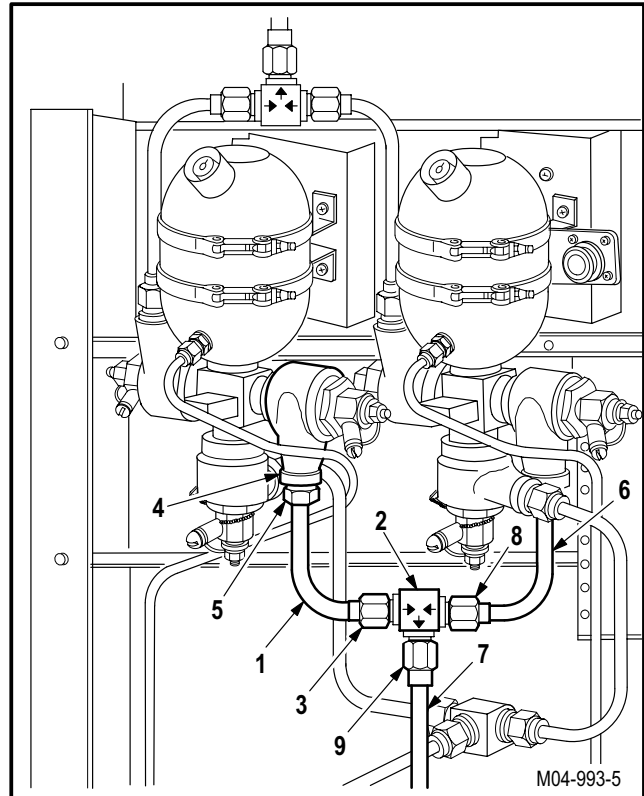

END OF TASK



**12.43. NO. 1 ENGINE FIRE EXTINGUISHER FITTING REPLACEMENT**

12.43.1. Description

This task covers: Removal. Cleaning. Inspection. Installation.

12.43.2. Initial Setup

**Tools:**

- Aircraft mechanic's tool kit (item 376, App H)
- 1 x 3/8-inch drive open end socket wrench crowfoot attachment (item 93, App H)
- 1 1/16 & 1 1/4-inch open end wrench (item 416, App H)
- 1 & 1 1/8-inch open end wrench (item 417, App H)
- 150 - 750 inch-pound 3/8-inch drive click type torque wrench (item 442, App H)

**Equipment Conditions:**

<u>Ref</u>	<u>Condition</u>
1.57	Helicopter safed
2.2	Access doors T250L, T250R, T290L, T290R, L325, and LN1 opened

**Personnel Required:**

- 67R Attack Helicopter Repairer  
One person to assist
- 67R3F Attack Helicopter Repairer/Technical Inspector

12.43.3. Removal

**a. Remove fire extinguisher tube (1).**

- (1) Hold check valve (2). Remove nut (3). Use open end wrench and crowfoot.
- (2) Hold nipple (4). Remove nut (5). Use open end wrench and crowfoot.

**b. Remove fire extinguisher fitting (6) from fire wall (7).**

- (1) Hold three screws (8).
- (2) Have one person remove three nuts (9) and washers (10).

**c. Remove nipple (4) from fitting (6).**

- (1) Hold nut (11). Remove nipple (4). Use open end wrench and crowfoot.
- (2) Discard fitting (6).

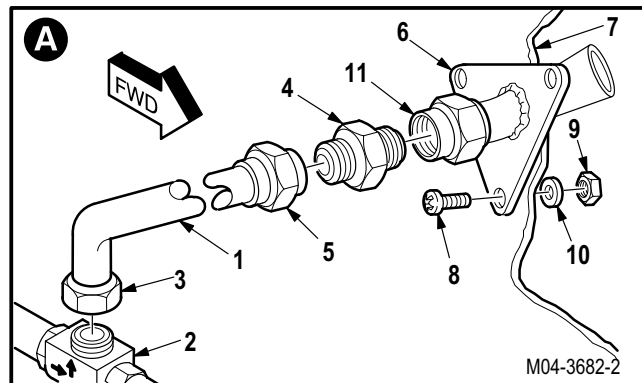
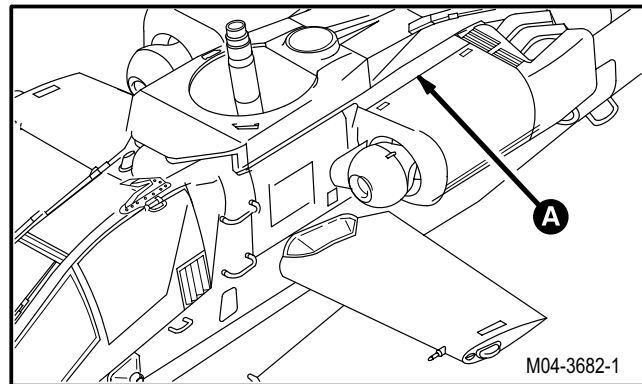

GO TO NEXT PAGE



---

**12.43. NO. 1 ENGINE FIRE EXTINGUISHER FITTING REPLACEMENT - continued**

---

12.43.4. Cleaning

- a. **Wipe removed and attaching parts with a clean rag.**

12.43.5. Inspection

- a. **Check removed and attaching parts for stripped or damaged threads** (para 12.33).
- b. **Check removed and attaching parts for corrosion** (para 1.49).

12.43.6. Installation

- a. **Install nipple (4) on new fitting (6).** Torque nut (11) to **345 INCH-POUNDS**.

- (1) Install and hold nipple (4). Use open end wrench.
- (2) Torque nut (11) to **345 INCH-POUNDS**. Use crowfoot and torque wrench.

- b. **Install fitting (6) on fire wall (7).**

- (1) Position fitting (6) on fire wall (7).
- (2) Install and hold three screws (8).
- (3) Have one person install three washers (10) and nuts (9).

- c. **Install tube (1).**

- (1) Install nut (3) and nut (5) finger tight on check valve (2) and nipple (4).
- (2) Hold nipple (4). Tighten nut (5). Use open end wrench and crowfoot.
- (3) Hold valve (2). Tighten nut (3). Use open end wrench and crowfoot.

- d. **Inspect (QA).**

- e. **Secure access doors T250L, T250R, T290L, T290R, L325, and LN1** (para 2.2).

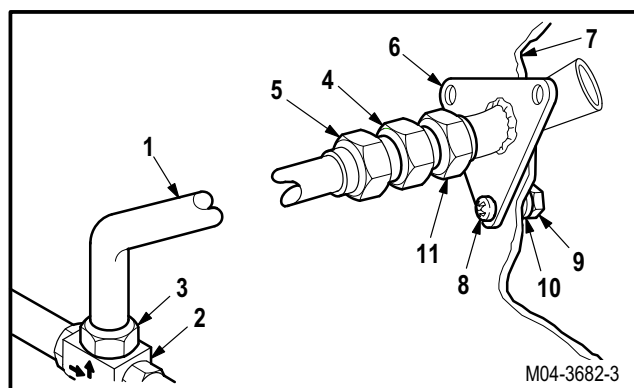

END OF TASK

**12.44. NO. 2 ENGINE FIRE EXTINGUISHER FITTING REPLACEMENT**

12.44.1. Description

This task covers: Removal. Cleaning. Inspection. Installation.

12.44.2. Initial Setup

**Tools:**

- Aircraft mechanic's tool kit (item 376, App H)
- 1 x 3/8-inch drive open end socket wrench crowfoot attachment (item 93, App H)
- 150 - 750 inch-pound 3/8-inch drive click type torque wrench (item 442, App H)

**Equipment Conditions:**

<u>Ref</u>	<u>Condition</u>
1.57	Helicopter safed
2.2	Access doors T250L, T250R, T290L, T290R, L325, and RN1 opened
15.41	APU enclosure upper center cover and upper forward panel removed

**Personnel Required:**

- 67R Attack Helicopter Repairer  
One person to assist
- 67R3F Attack Helicopter Repairer/Technical Inspector

12.44.3. Removal

a. **Remove fire extinguisher fitting (1) from fire wall (2).**

- (1) Hold elbow (3). Remove nut (4). Use crowfoot.
- (2) Hold three screws (5).
- (3) Have one person remove three nuts (6) and washers (7).
- (4) Remove and discard fitting (1).

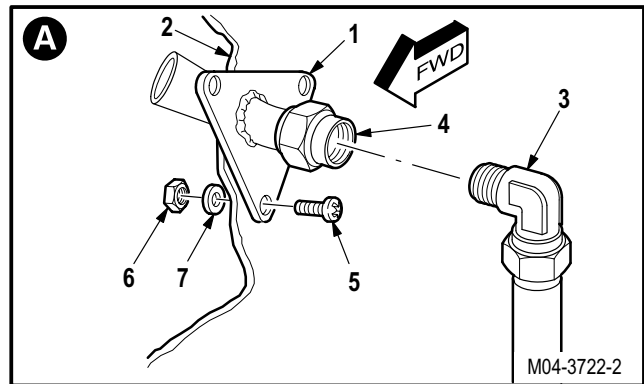
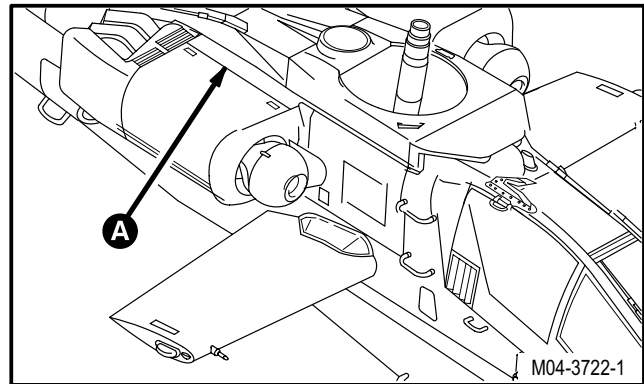

GO TO NEXT PAGE

---

**12.44. NO. 2 ENGINE FIRE EXTINGUISHER FITTING REPLACEMENT - continued**

---

12.44.4. Cleaning

- a. **Wipe removed and attaching parts with a clean rag.**

12.44.5. Inspection

- a. **Check removed and attaching parts for stripped or damaged threads** (para 12.33).
- b. **Check removed and attaching parts for corrosion** (para 1.49).

12.44.6. Installation

- a. **Install new fitting (1) on fire wall (2).** Torque nut (4) to **345 INCH-POUNDS**.

- (1) Position fitting (1) on fire wall (2).
- (2) Install and hold three screws (5).
- (3) Have one person install three washers (7) and nuts (6).
- (4) Hold elbow (3).
- (5) Torque nut (4) to **345 INCH-POUNDS**. Use crowfoot and torque wrench.

- b. **Inspect (QA).**
- c. **Install APU enclosure upper center cover and upper forward panel** (para 15.42).
- d. **Secure access doors T250L, T250R, T290L, T290R, L325, and RN1** (para 2.2).

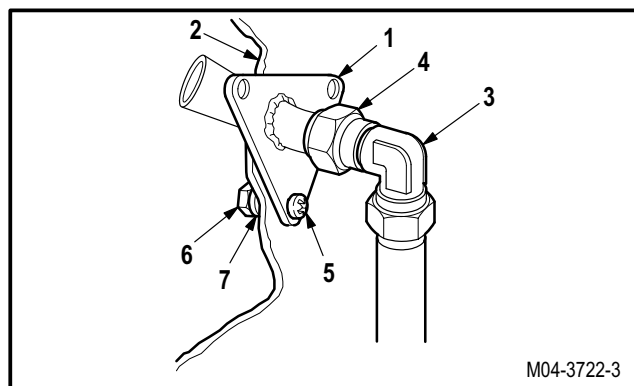

END OF TASK

**12.45. THERMAL DISCHARGE INDICATOR REPLACEMENT**

12.45.1. Description

This task covers: Removal. Cleaning. Inspection. Installation.

12.45.2. Initial Setup

**Tools:**

Aircraft mechanic's tool kit (item 376, App H)

**Personnel Required:**

67R Attack Helicopter Repairer  
 67R3F Attack Helicopter Repairer/Technical Inspector

**Materials/Parts:**

Gasket  
 Packing

**Equipment Conditions:**

<u>Ref</u>	<u>Condition</u>
1.57	Helicopter safed

12.45.3. Removal

a. **Remove thermal discharge disk indicator (1) from indicator housing (2).**

- (1) Remove snap ring (3) and gasket (4) from housing (2).
- (2) Remove and discard indicator (1) and packing (5).

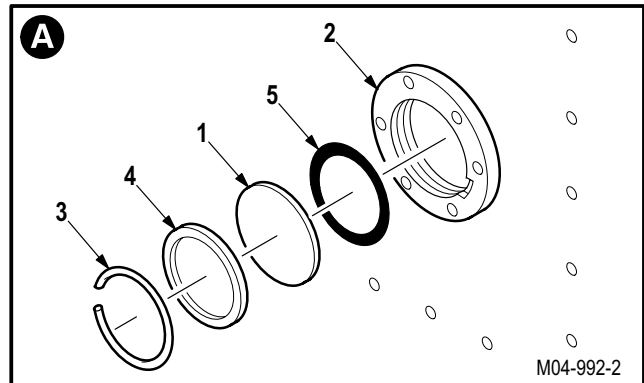
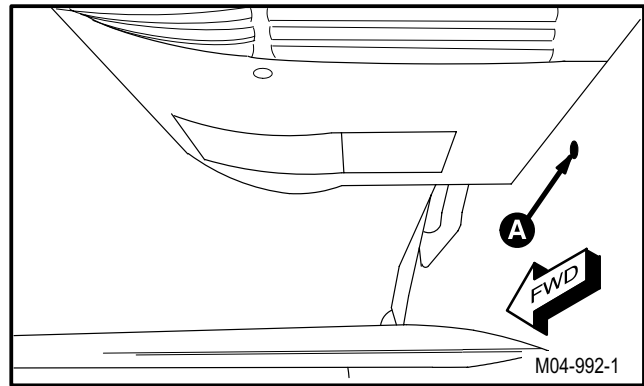

GO TO NEXT PAGE

---

**12.45. THERMAL DISCHARGE INDICATOR REPLACEMENT - continued**

---

12.45.4. Cleaning

- a. **Wipe removed and attaching parts with a clean rag.**

12.45.5. Inspection

- a. **Check indicator housing for nicks, cracks, or scratches** (para 12.33).
- b. **Check removed and attaching parts for corrosion** (para 1.49).

12.45.6. Installation

- a. **Install new indicator (1) in housing (2).**

- (1) Install new packing (5) in housing (2).
- (2) Install indicator (1) in housing (2), with glossy side facing outboard.
- (3) Install gasket (4) and snap ring (3) in housing (2).

- b. **Inspect (QA).**

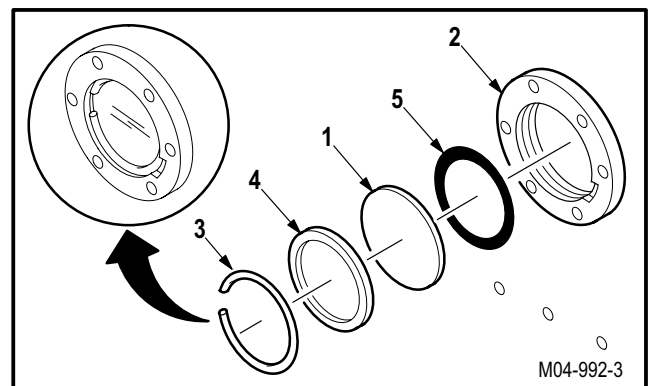

END OF TASK

## SECTION IV. ANTI-ICE/DE-ICE SYSTEM MAINTENANCE

### 12.46. ANTI-ICE/DE-ICE SYSTEM INSPECTION

#### 12.46.1. Description

This task covers: Inspection.

#### 12.46.2. Initial Setup

**Tools:**

Aircraft mechanic's tool kit (item 376, App H)

**References:**

TM 55-1500-323-24

**Personnel Required:**

67R      Attack Helicopter Repairer  
 67R3F   Attack Helicopter Repairer/Technical  
           Inspector

**Equipment Conditions:**

<u>Ref</u>	<u>Condition</u>
1.57	Helicopter safed

#### 12.46.3. Inspection

- a. **Check anti-ice panels for illegible lettering, damaged indicator lights, and loose knobs or switches.** None allowed.
- b. **Check components for nicks, dents, scratches, and gouges.**
  - (1) Minor scratches without burrs or raised material that does not penetrate through protective finish are acceptable.
  - (2) Nicks and gouges that exceed **0.040 INCH** or 10 percent of material thickness are not allowed.
- c. **Check components for cracks.** None allowed.
- d. **Check components for corrosion** (para 1.49).
- e. **Check general mounting hardware for cracks, gouges, nicks, scratches, chafing, damage, rounded flats, and stripped or damaged threads.** Replace damaged hardware.
- f. **Check connectors for loose or bent pins, loose wires, and stripped or damaged threads** (TM 55-1500-323-24).
- g. **Check connectors for smooth operation and positive locking action** (TM 55-1500-323-24).
- h. **Check wire harness for cuts, nicks, chafing, fraying, and security of installation** (TM 55-1500-323-24).

END OF TASK

**12.47. PILOT ANTI-ICE PANEL ASSEMBLY REMOVAL/INSTALLATION**

12.47.1. Description

This task covers: Removal. Cleaning. Inspection. Installation.

12.47.2. Initial Setup

**Tools:**

Electrical tool kit (item 378, App H)

**Personnel Required:**

68X Armament/Electrical System Repairer  
 68X3F Armament/Electrical System Repairer/  
 Technical Inspector

**References:**

TM 1-1520-238-T

**Equipment Conditions:**

<u>Ref</u>	<u>Condition</u>
1.57	Helicopter safed

12.47.3. Removal

- a. **Enter pilot station** (para 1.56). **Observe all safety precautions.**
- b. **On pilot forward circuit breaker panel, open AIR DATA AC circuit breaker.**
- c. **On pilot center circuit breaker panel, open PI-TOT HT and LT PRI circuit breakers.**
- d. **On pilot aft circuit breaker panel, open ECS WSHLD WPR, CANOPY ANTI-ICE CONTR, ENG ANTI-ICE, and BLADE DE-ICE circuit breakers.**
- e. **Remove pilot ANTI-ICE panel (1) from console (2).**
  - (1) Unlock four turnlock fasteners (3).
  - (2) Remove panel (1) from console (2).
  - (3) Detach connector P178 (4) from receptacle (A135)J1 (5).

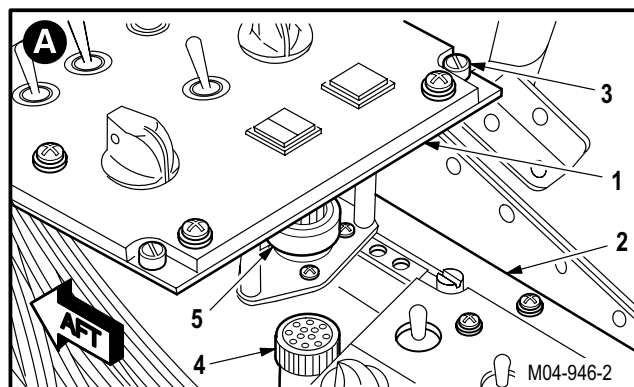
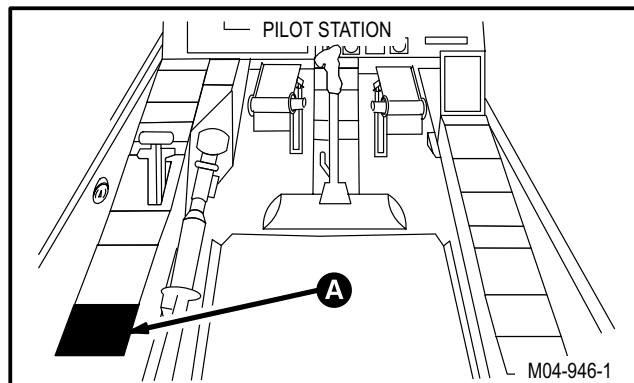

GO TO NEXT PAGE

**12.47. PILOT ANTI-ICE PANEL ASSEMBLY REMOVAL/INSTALLATION - continued**

12.47.4. Cleaning

- a. **Wipe removed and attaching parts with a clean rag.**

12.47.5. Inspection

- a. **Check panel for illegible lettering, damaged indicator lights, and loose knobs or switches (para 12.46).**
- b. **Check panel for nicks, dents, and cracks (para 12.46).**
- c. **Check connectors for loose or bent pins, and loose or chafed wires (para 12.46).**
- d. **Check removed and attaching parts for corrosion (para 1.49).**

12.47.6. Installation

- a. **Install panel (1) on console (2).**

- (1) Attach connector P178 (4) to receptacle (A135)J1 (5).
- (2) Install panel (1) on console (2).
- (3) Lock four turnlock fasteners (3).

- b. **Inspect (QA).**

- c. **Perform pitot anti-ice, rotor blades de-ice, windshield wipers, and canopy defog and anti-ice maintenance operational checks (TM 1-1520-238-T).**

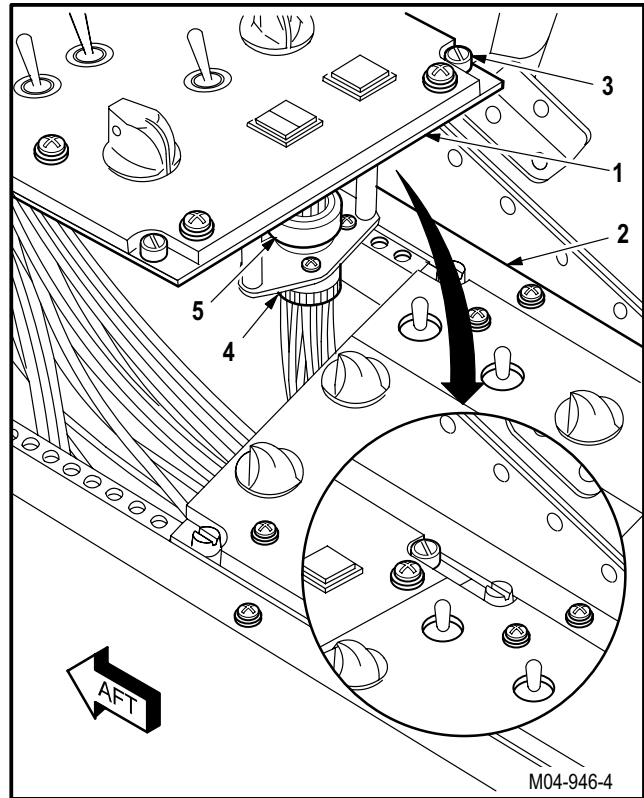

END OF TASK



---

**12.48. PILOT ANTI-ICE PANEL LIGHT INDICATING PANEL REMOVAL/INSTALLATION**

---

12.48.1. Description

This task covers: Removal. Cleaning. Inspection. Installation.

---

12.48.2. Initial Setup

**Tools:**

Electrical tool kit (item 378, App H)

**References:**

TM 1-1520-238-T

**Personnel Required:**

68X Armament/Electrical System Repairer  
 68X3F Armament/Electrical System Repairer/  
 Technical Inspector

**Equipment Conditions:**

<u>Ref</u>	<u>Condition</u>
1.57	Helicopter safed

**NOTE**

This task can be performed on helicopter or off helicopter.

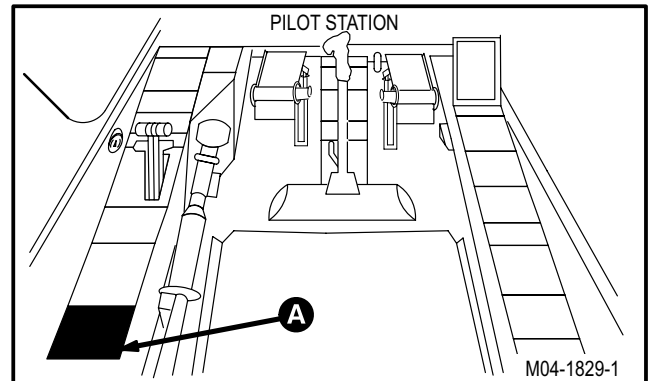

GO TO NEXT PAGE

**12.48. PILOT ANTI-ICE PANEL LIGHT INDICATING PANEL REMOVAL/INSTALLATION - continued**

12.48.3. Removal

a. **Remove knob (1) from switch shaft (2).**

- (1) Loosen two screws (3).
- (2) Remove knob (1).

b. **Remove knob (4) from switch shaft (5).**

- (1) Loosen two screws (6).
- (2) Remove knob (4).

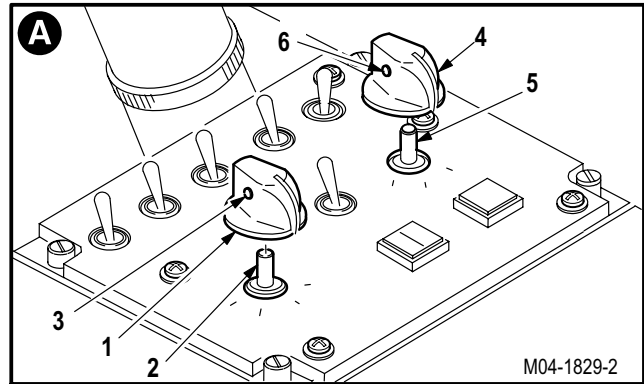

c. **Remove light indicating panel (7) from support panel (8).**

- (1) Remove five screws (9).
- (2) Remove panel (7) from panel (8).

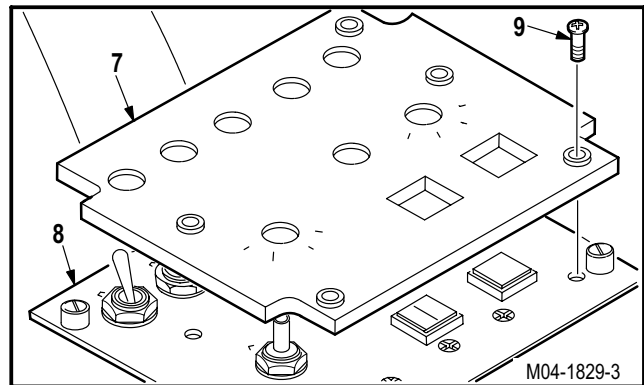

12.48.4. Cleaning

a. **Wipe removed and attaching parts with a clean rag.**

12.48.5. Inspection

- a. **Check panel for nicks, dents, and cracks** (para 12.46).
- b. **Check removed and attaching parts for corrosion** (para 1.49).

GO TO NEXT PAGE

**12.48. PILOT ANTI-ICE PANEL LIGHT INDICATING PANEL REMOVAL/INSTALLATION - continued**

12.48.6. Installation

**a. Install panel (7) on panel (8).**

- (1) Position panel (7) on panel (8).
- (2) Install five screws (9).

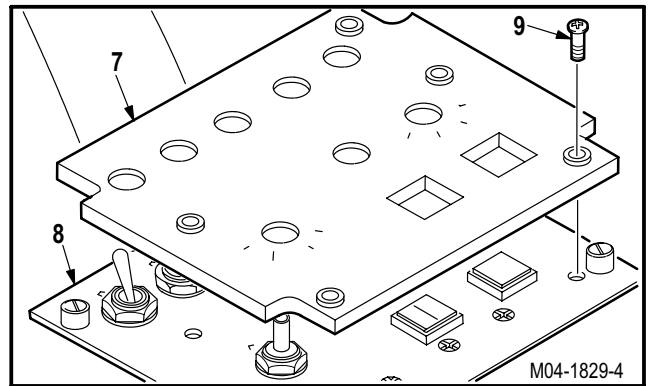

**b. Install knob (4) on shaft (5).**

- (1) Position knob (4) on shaft (5).
- (2) Tighten two screws (6).

**c. Install knob (1) on shaft (2).**

- (1) Position knob (1) on shaft (2).
- (2) Tighten two screws (3).

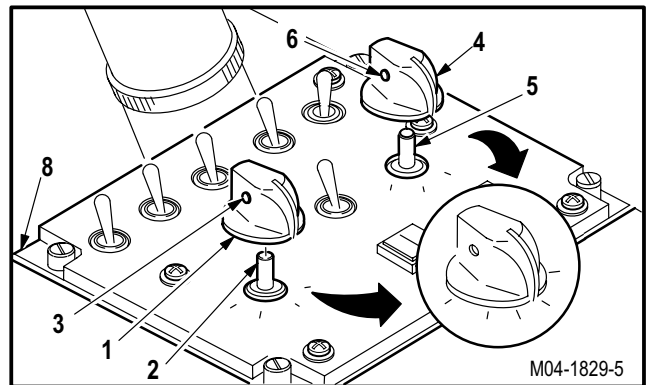

**d. Inspect (QA).**

**e. Perform pilot edge-lights maintenance operational check (TM 1-1520-238-T).**

END OF TASK

---

## 12.49. PILOT ANTI-ICE PANEL SWITCH REPLACEMENT (AVIM)

---

### 12.49.1. Description

This task covers: Removal. Cleaning. Inspection. Installation.

---

### 12.49.2. Initial Setup

#### Tools:

Electrical tool kit (item 378, App H)  
Light duty laboratory apron (item 27, App H)  
Chemical protective gloves (item 154, App H)  
Adjustable air filtering respirator (item 262, App H)  
Soldering gun (item 334, App H)

#### Personnel Required:

68X Armament/Electrical System Repairer  
68X3F Armament/Electrical System Repairer/  
Technical Inspector

#### References:

TM 55-1500-323-24

#### Equipment Conditions:

<u>Ref</u>	<u>Condition</u>
12.48	Pilot ANTI-ICE panel light indicating panel removed

#### Materials/Parts:

Solder (item 189, App F)

---

### NOTE

This task is typical for switches on the pilot **ANTI-ICE** panel. Switches differ in number and placement of wires and jumpers.

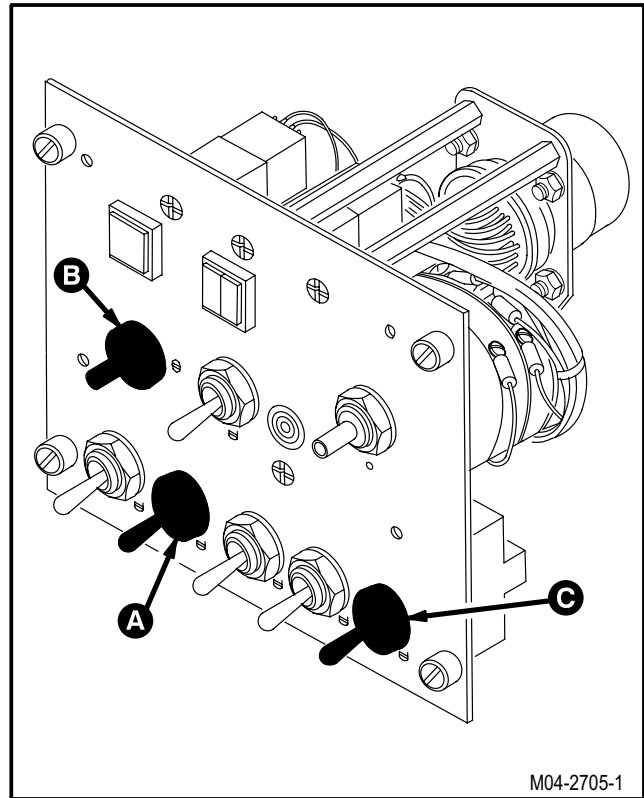

GO TO NEXT PAGE

12.49. PILOT ANTI-ICE PANEL SWITCH REPLACEMENT (AVIM) - continued

12.49.3. Removal



**WARNING**

Soldering gun can cause severe burns to personnel and start fires. Observe all safety precautions when using soldering gun. If injury occurs, seek medical aid.

a. Desolder wires (1) from switch (2).

- (1) Identify and desolder wires (1) from terminals (3). Use soldering gun (TM 55-1500-323-24).

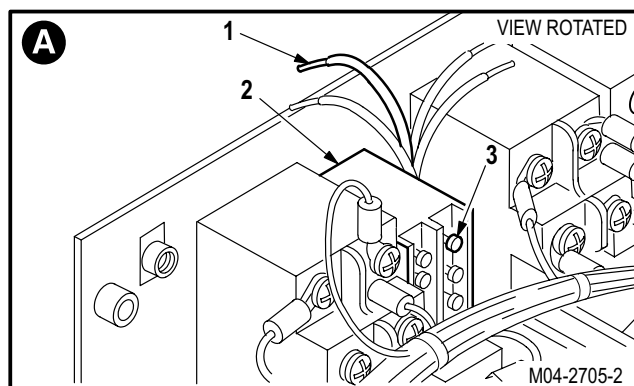

b. Remove switch (2) from support panel (4).

- (1) Remove nut (5) and lockwasher (6) from switch (2).
- (2) Remove switch (2) and lockring (7) from panel (4).

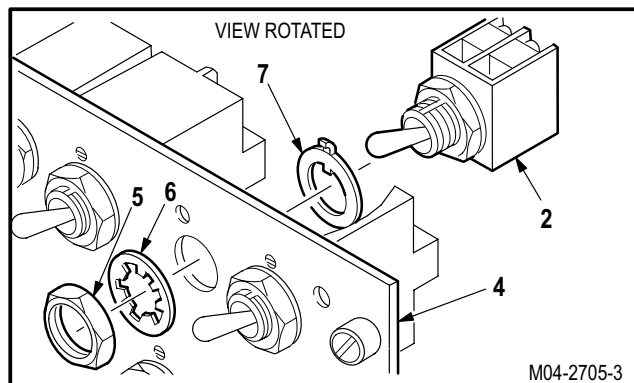

c. Desolder wires (8) from switch (9).

- (1) Identify and desolder wires (8) from terminals (10). Use soldering gun (TM 55-1500-323-24).

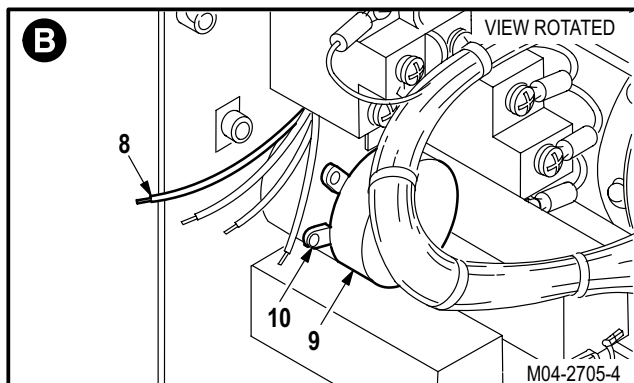

GO TO NEXT PAGE

**12.49. PILOT ANTI-ICE PANEL SWITCH REPLACEMENT (AVIM) - continued**

**d. Remove switch (9) from panel (4).**

- (1) Remove nut (11) and lockwasher (12) from switch (9).
- (2) Remove switch (9) and lockring (13) from panel (4).

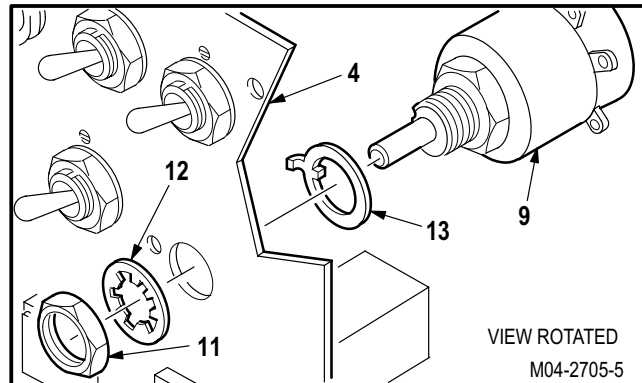

**e. Detach wires (14) and jumpers (15) from switch (16).**

- (1) Identify wires (14) and jumpers (15).
- (2) Remove screws (17), lockwashers (18), and terminal lugs (19).

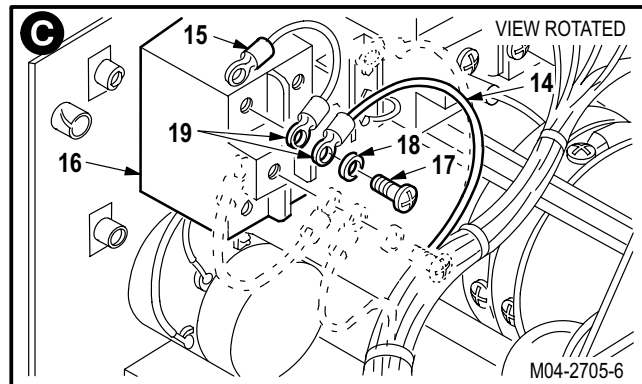

**f. Remove switch (16) from panel (4).**

- (1) Remove nut (20) and lockwasher (21) from switch (16).
- (2) Remove switch (16) and lockring (22) from panel (4).

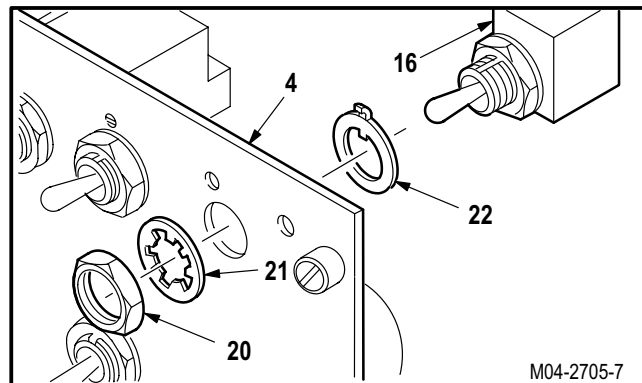

**12.49.4. Cleaning**

- a. **Wipe removed and attaching parts with a clean rag.**

**12.49.5. Inspection**

- a. **Check panel for nicks, dent, or cracks** (para 12.46).
- b. **Check switches for loose terminals, cracks, or signs of overheating** (para 12.46).
- c. **Check removed and attaching parts for corrosion** (para 1.49).

GO TO NEXT PAGE

**12.49. PILOT ANTI-ICE PANEL SWITCH REPLACEMENT (AVIM) - continued**

12.49.6. Installation

**a. Install switch (2) on panel (4).**

- (1) Install switch (2) so tab (23) on lockring (7) seats in locator hole (24).
- (2) Install lockwasher (6) and nut (5) on switch (2).



**WARNING**

**Soldering gun can cause severe burns to personnel and start fires. Observe all safety precautions when using soldering gun. If injury occurs, seek medical aid.**

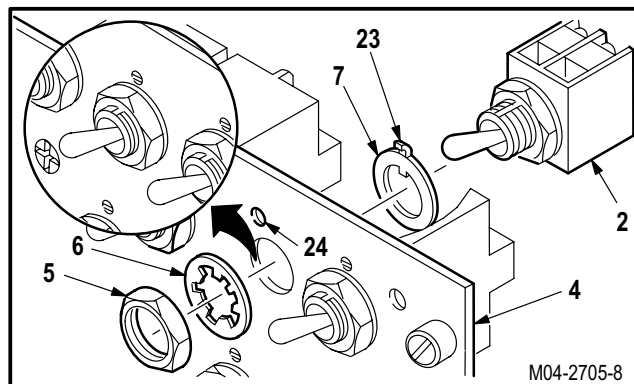

**b. Solder wires (1) to switch (2).**

- (1) Solder identified wires (1) to terminals (3). Use solder (item 189, App F) and soldering gun (TM 55-1500-323-24).

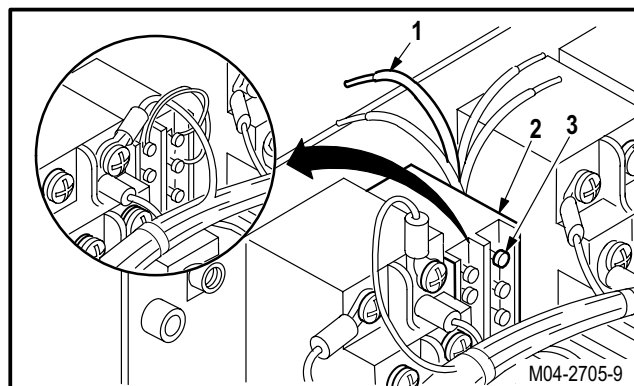

**c. Install switch (9) on panel (4).**

- (1) Install switch (9) so tab (25) on lockring (13) seats in locator hole (26).
- (2) Install lockwasher (12) and nut (11) on switch (9).

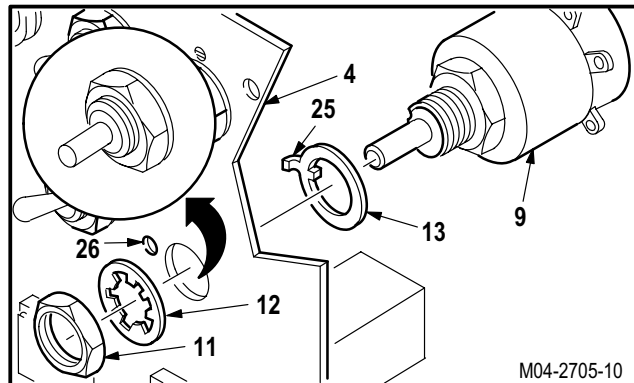

GO TO NEXT PAGE

**12.49. PILOT ANTI-ICE PANEL SWITCH REPLACEMENT (AVIM) - continued**

**d. Solder wires (8) to switch (9).**

- (1) Solder identified wires (8) to terminals (10). Use solder (item 189, App F) and soldering gun (TM 55-1500-323-24).

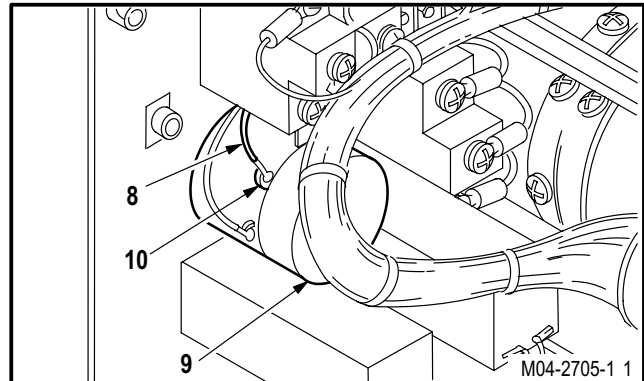

**e. Install switch (16) on panel (4).**

- (1) Insert switch (16) so that tab (27) on locking (22) seats in locator hole (28).
- (2) Install lockwasher (21) and nut (20) on switch (16).

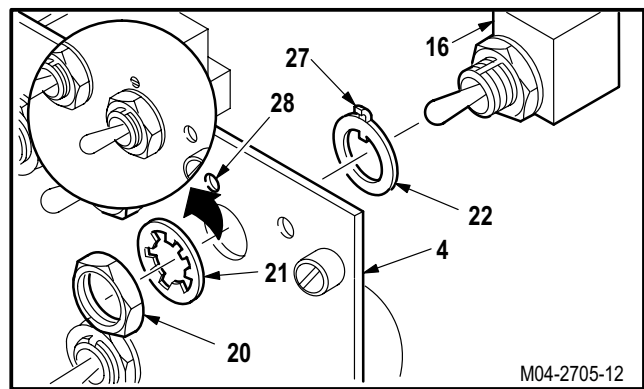

**f. Attach wires (14) and jumpers (15) to switch (16).**

- (1) Position identified wires (14) and jumpers (15) on switch (16).
- (2) Install screws (17), lockwashers (18), and terminal lugs (19).

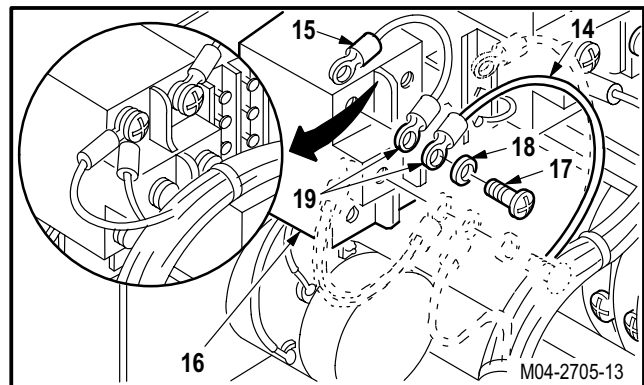

**g. Inspect (QA).**

**h. Install pilot ANTI-ICE panel light indicating panel (para 12.48).**

END OF TASK



---

## 12.50. PILOT ANTI-ICE PANEL RECEPTACLE REPLACEMENT

---

### 12.50.1. Description

This task covers: Removal. Cleaning. Inspection. Installation.

---

### 12.50.2. Initial Setup

#### Tools:

Electrical tool kit (item 378, App H)  
 Light duty laboratory apron (item 27, App H)  
 Chemical protective gloves (item 154, App H)  
 Adjustable air filtering respirator (item 262, App H)

#### Materials/Parts:

Sealing compound (item 169, App F)

#### Personnel Required:

68X Armament/Electrical System Repairer  
 68X3F Armament/Electrical System Repairer/  
 Technical Inspector

#### References:

- TM 1-1500-204-23
- TM 55-1500-323-24

#### Equipment Conditions:

<u>Ref</u>	<u>Condition</u>
12.48	Pilot ANTI-ICE panel light indicating panel removed

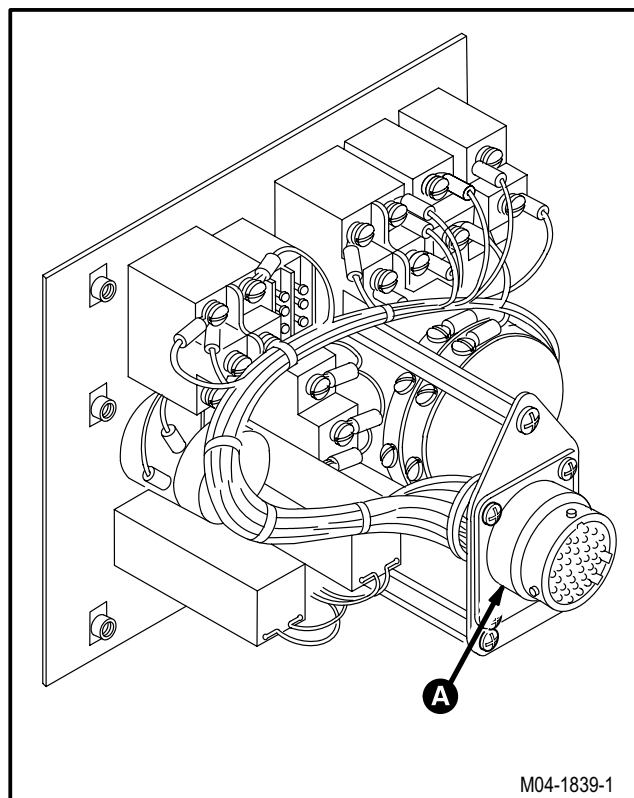

GO TO NEXT PAGE

■ 12.50. PILOT ANTI-ICE PANEL RECEPTACLE REPLACEMENT - continued

12.50.3. Removal

a. Remove backshell (1) from receptacle (A135)J1 (2).

- (1) Remove backshell (1).
- (2) Slide backshell (1) over wires (3) so back of receptacle (2) is accessible.

b. Remove receptacle (2) from connector bracket (4).

- (1) Remove four screws (5), washers (6), and nuts (7).

c. Identify and depin wires (3) from receptacle (2) (TM 55-1500-323-24).

d. Remove and discard receptacle (2).

**NOTE**

To remove connector bracket or posts, go to step e. If removal not required, go to paragraph 12.50.4.

e. Remove bracket (4) from three posts (8).

- (1) Remove three screws (9), lockwashers (10), and washers (11) from posts (8).
- (2) Remove bracket (4).

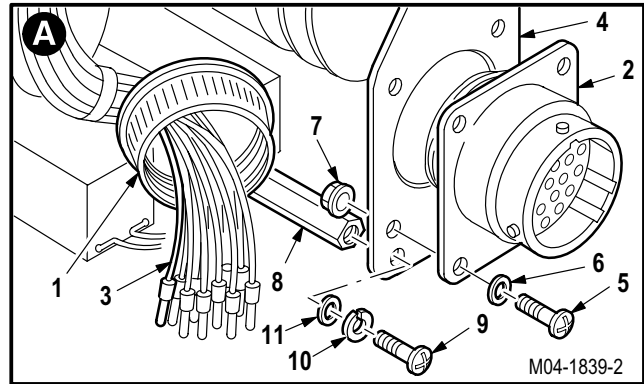

GO TO NEXT PAGE

**12.50. PILOT ANTI-ICE PANEL RECEPTACLE REPLACEMENT - continued****f. Remove three posts (8) from panel (12).**

- (1) Remove three screws (13) from posts (8).
- (2) Remove posts (8).

**12.50.4. Cleaning**

- a. **Clean sealing compound from removed parts** (para 1.47).
- b. **Wipe removed and attaching parts with a clean rag.**

**12.50.5. Inspection**

- a. **Check wires for cuts, nicks, fraying, or chafing** (para 12.46).
- b. **Check removed and attaching parts for corrosion** (para 1.49).
- c. **Check removed and attaching parts for cracks** (TM 1-1500-204-23).

**12.50.6. Installation****NOTE**

If connector bracket or posts were removed, go to step a. If bracket and posts were not removed, go to step d.

**a. Install three posts (8) on panel (12).**

- (1) Apply sealing compound on three screws (13). Use sealing compound (item 169, App F).
- (2) Install three screws (13) through panel (12) into posts (8).

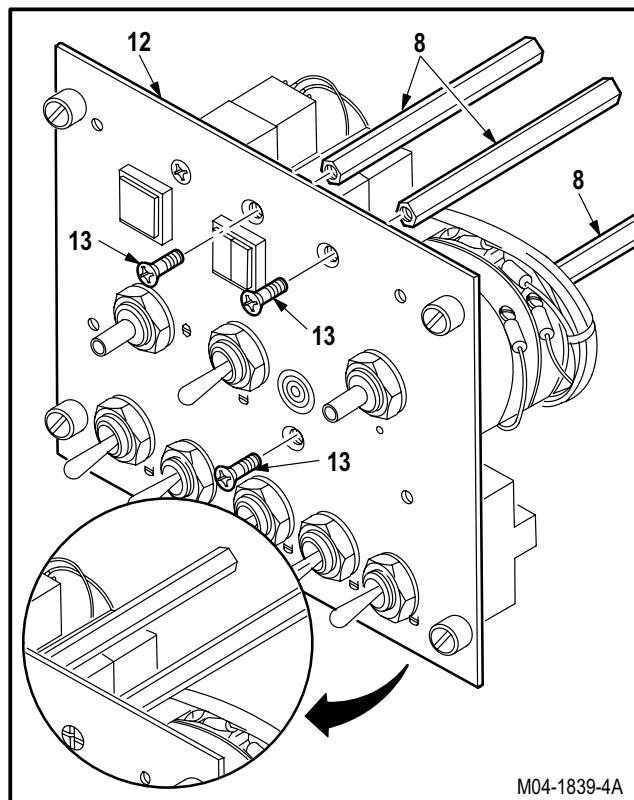

GO TO NEXT PAGE

**12.50. PILOT ANTI-ICE PANEL RECEPTACLE REPLACEMENT - continued**

**b. Install bracket (4) on three posts (8).**

- (1) Apply sealing compound on three screws (9). Use sealing compound (item 169, App F).
- (2) Install three screws (9) through lockwashers (10), washers (11), and bracket (4) into posts (8).

**c. Pin wires (3) in new receptacle (2).**

- (1) Route wires (3) through backshell (1) and bracket (4).
- (2) Pin identified wires (3) in receptacle (2) (TM 55-1500-323-24).
- (3) Install backshell (1) on receptacle (2).

**d. Install receptacle (2) on bracket (4).**

- (1) Install four screws (5), washers (6), and nuts (7).

**e. Inspect (QA).**

**f. Install pilot ANTI-ICE panel light indicating panel (para 12.48).**

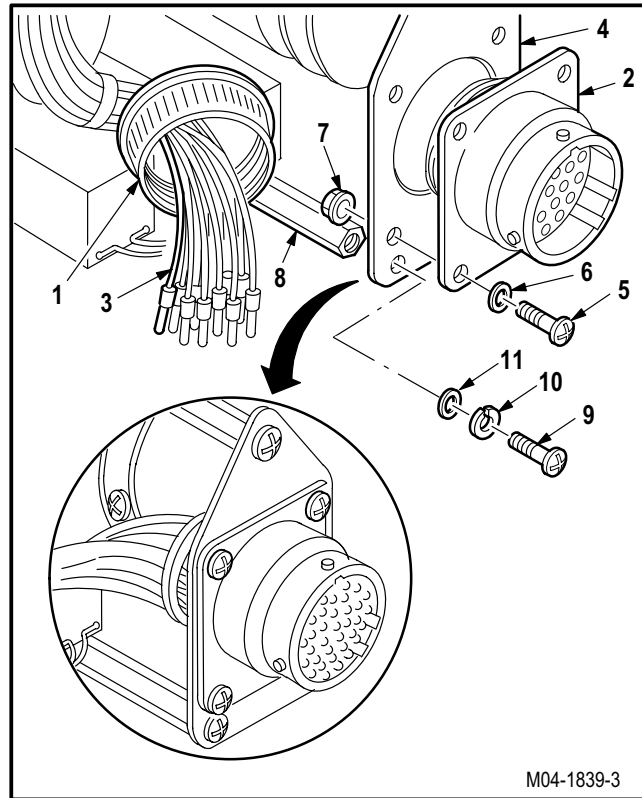

END OF TASK

---

**12.51. PILOT ANTI-ICE PANEL LIGHT INDICATING PANEL RECEPTACLE REPLACEMENT (AVIM)**

---

12.51.1. Description

This task covers: Removal. Cleaning. Inspection. Installation.

---

12.51.2. Initial Setup

**Tools:**

Electrical tool kit (item 378, App H)

**Personnel Required:**

68X Armament/Electrical System Repairer  
 68X3F Armament/Electrical System Repairer/  
 Technical Inspector

**Equipment Conditions:**

<u>Ref</u>	<u>Condition</u>
12.48	Pilot ANTI-ICE panel light indicating panel removed

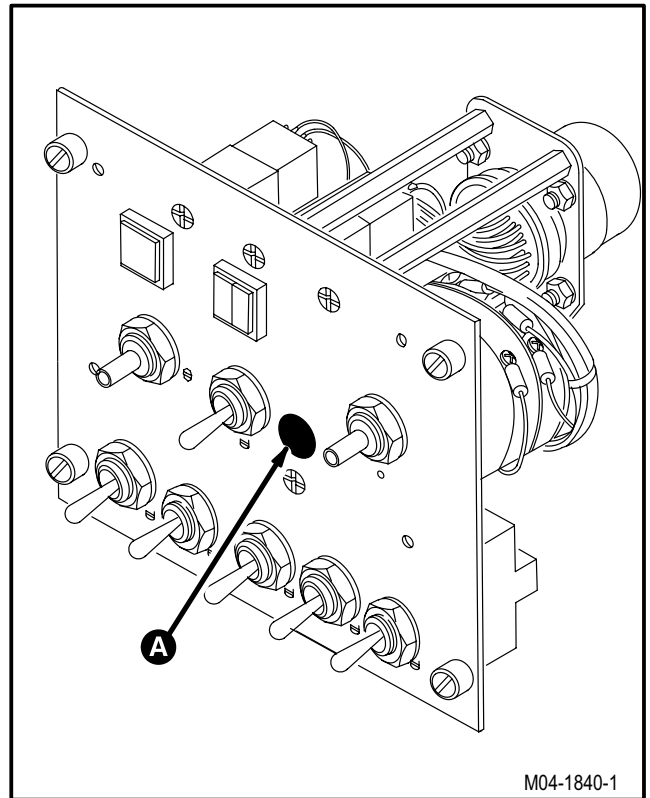

GO TO NEXT PAGE

**12.51. PILOT ANTI-ICE PANEL LIGHT INDICATING PANEL RECEPTACLE REPLACEMENT (AVIM) - continued**

12.51.3. Removal

a. **Detach wire (1) from terminal (2).**

- (1) Remove screw (3), washer (4), and terminal lug (5).

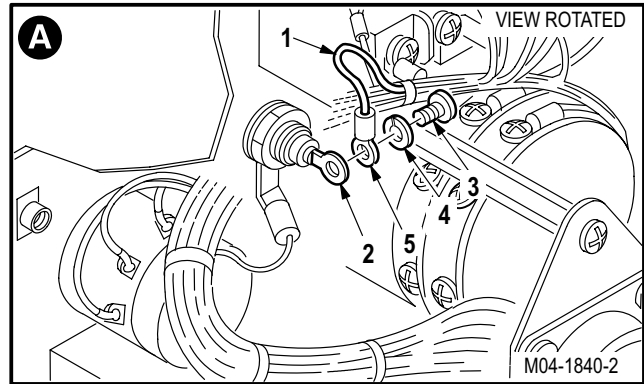

b. **Remove receptacle (6) from support panel (7).**

- (1) Remove nut (8), washer (9), and terminal lug (10).
- (2) Remove receptacle (6) from panel (7).

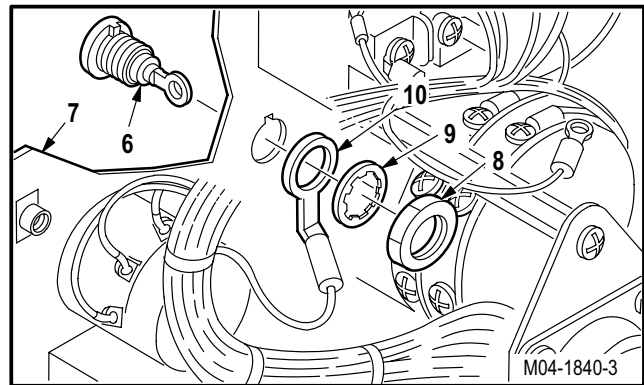

12.51.4. Cleaning

a. **Wipe removed and attaching parts with a clean rag.**

12.51.5. Inspection

- a. **Check for loose or frayed wires on terminal lugs** (para 12.46).
- b. **Check panel for nicks, dents, or cracks** (para 12.46).
- c. **Check switches for loose terminals, cracks, and signs of overheating** (para 12.46).
- d. **Check removed and attaching parts for corrosion** (para 1.49).

GO TO NEXT PAGE

---

**12.51. PILOT ANTI-ICE PANEL LIGHT INDICATING PANEL RECEPTACLE REPLACEMENT (AVIM) - continued**



---

12.51.6. Installation**a. Install receptacle (6) on panel (7).**

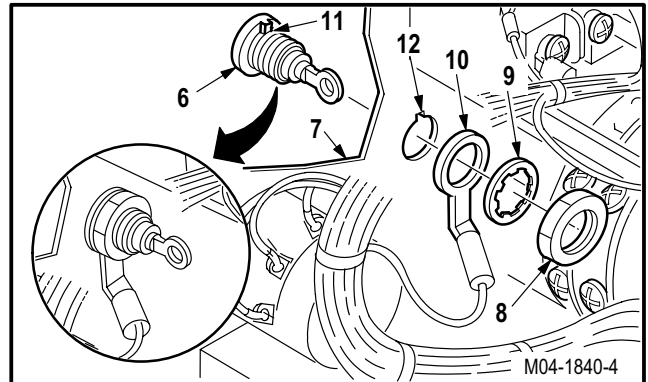
- (1) Install receptacle (6) through opening in front of support panel (7) so that tab (11) aligns with notch (12).
- (2) Install terminal lug (10), washer (9), and nut (8).

**b. Attach wire (1) to terminal (2).**

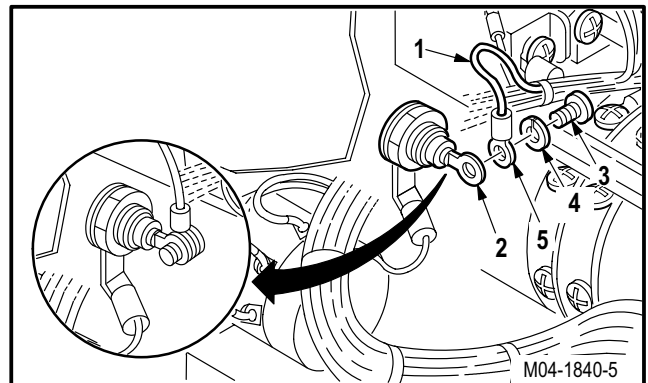
- (1) Position terminal lug (5) on terminal (2).
- (2) Install screw (3) and washer (4).

**c. Inspect (QA).****d. Install pilot ANTI-ICE panel light indicating panel (para 12.48).**

END OF TASK

---

## 12.52. PILOT ANTI-ICE PANEL INDICATOR SWITCH REPLACEMENT (AVIM)

---

### 12.52.1. Description

This task covers: Removal. Cleaning. Inspection. Installation.

---

### 12.52.2. Initial Setup

#### Tools:

Electrical tool kit (item 378, App H)  
Light duty laboratory apron (item 27, App H)  
Chemical protective gloves (item 154, App H)  
Adjustable air filtering respirator (item 262, App H)  
Soldering gun (item 334, App H)

#### Personnel Required:

68X Armament/Electrical System Repairer  
68X3F Armament/Electrical System Repairer/  
Technical Inspector

#### References:

TM 55-1500-323-24

#### Equipment Conditions:

<u>Ref</u>	<u>Condition</u>
12.48	Pilot ANTI-ICE panel light indicating panel removed

#### Materials/Parts:

Solder (item 189, App F)

---

#### NOTE

This task is typical for either indicator switch, DS1 or DS2.

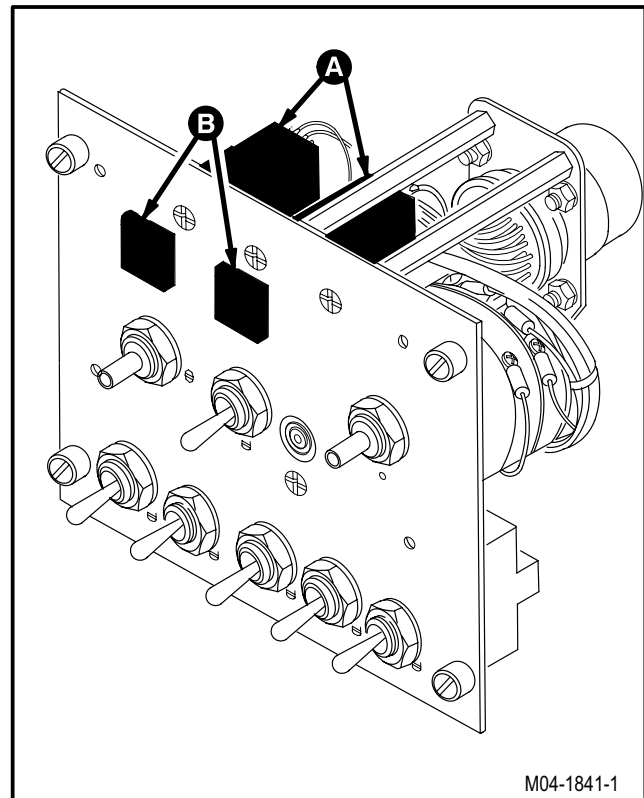

GO TO NEXT PAGE



**12.52. PILOT ANTI-ICE PANEL INDICATOR SWITCH REPLACEMENT (AVIM) - continued**

12.52.3. Removal



**WARNING**

**Soldering gun can cause severe burns to personnel and start fires. Observe all safety precautions when using soldering gun. If injury occurs, seek medical aid.**

a. **Desolder wires (1) from indicator switch (2).**

- (1) Identify and desolder wires (1) from terminals (3). Use soldering gun (TM 55-1500-323-24).

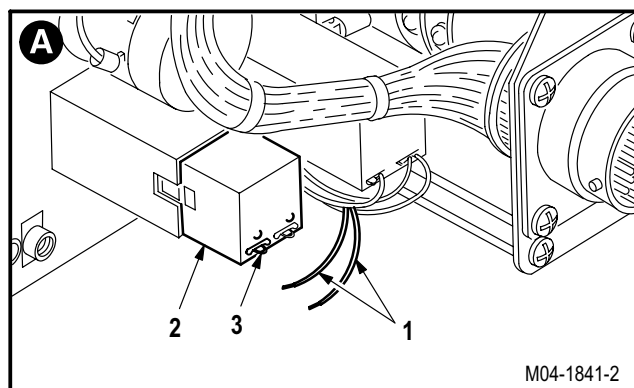

b. **Remove switch (2) from panel (4).**

- (1) Remove and move lens (5) to one side.
- (2) Loosen two screws (6).

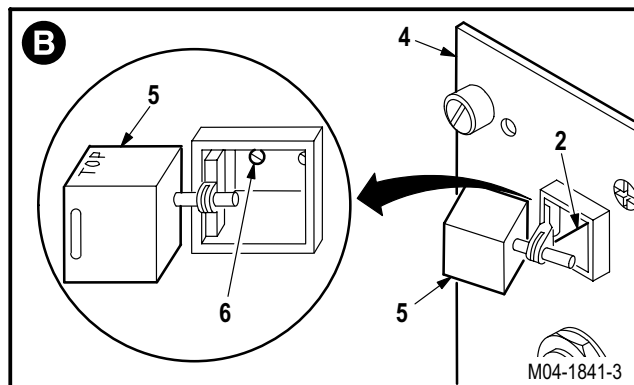

- (3) Hold spacer (7). Remove sleeve (8) from switch (2).

- (4) Remove switch (2) from panel (4).

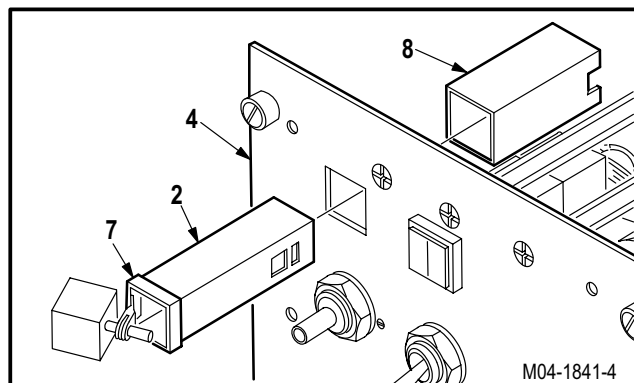

GO TO NEXT PAGE

---

**12.52. PILOT ANTI-ICE PANEL INDICATOR SWITCH REPLACEMENT (AVIM) - continued**

---

12.52.4. Cleaning

- a. **Wipe attaching parts with a clean rag.**

12.52.5. Inspection

- a. **Check panel for nicks, dents, or cracks** (para 12.46).
- b. **Check switches for loose terminals, cracks, and signs of overheating** (para 12.46).
- c. **Check attaching parts for corrosion** (para 1.49).

12.52.6. Installation

- a. **Install new switch (2) on panel (4).**

- (1) Place spacer (7) on switch (2).
- (2) Install switch (2) through opening in panel (4).
- (3) Position sleeve (8) on switch (2).
- (4) Tighten two screws (6).
- (5) Install lens (5).

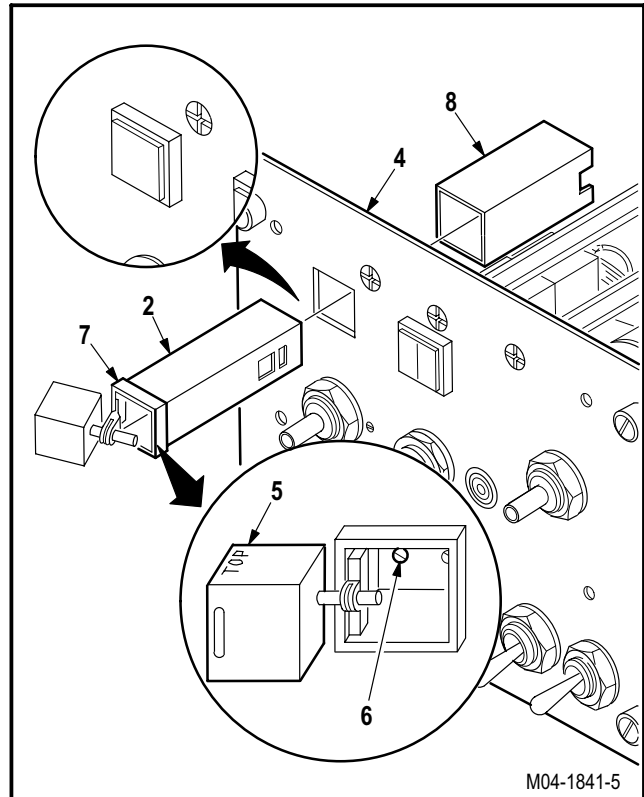

GO TO NEXT PAGE

---

**12.52. PILOT ANTI-ICE PANEL INDICATOR SWITCH REPLACEMENT (AVIM) - continued**

---

**WARNING**

**Soldering gun can cause severe burns to personnel and start fires. Observe all safety precautions when using soldering gun. If injury occurs, seek medical aid.**

**b. Solder wires (1) to switch (2).**

(1) Solder identified wires (1) to terminals (3). Use soldering gun and solder (item 189, App F) (TM 55-1500-323-24).

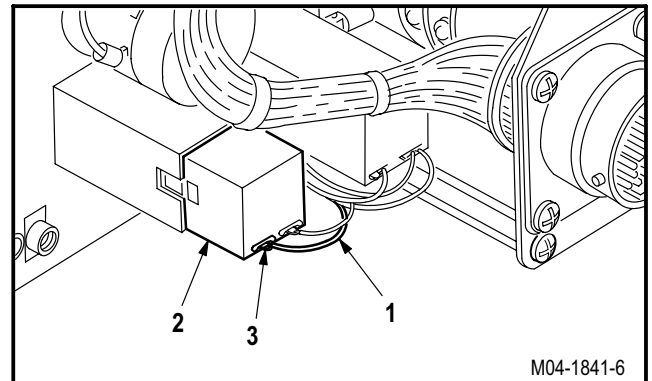
**c. Inspect (QA).****d. Install pilot ANTI-ICE panel light indicating panel (para 12.48).**

END OF TASK

**12.53. CPG AUXILIARY PANEL ASSEMBLY REMOVAL/INSTALLATION**

12.53.1. Description

This task covers: Removal. Cleaning. Inspection. Installation.

12.53.2. Initial Setup

**Tools:**

Electrical tool kit (item 378, App H)

**References:**

TM 1-1520-238-T

**Personnel Required:**

68X Armament/Electrical System Repairer  
 68X3F Armament/Electrical System Repairer/  
 Technical Inspector

**Equipment Conditions:**

<u>Ref</u>	<u>Condition</u>
1.57	Helicopter safed

12.53.3. Removal

- a. **Enter pilot station (para 1.56). Observe all safety precautions.**
- b. **On pilot forward circuit breaker panel, open AIR DATA DC circuit breaker.**
- c. **On pilot center circuit breaker panel, open LT PRI circuit breaker.**
- d. **On pilot aft circuit breaker panel, open ECS CAB, WSHLD WPR, and CANOPY ANTI-ICE CONTR circuit breakers.**
- e. **Enter CPG station (para 1.56). Observe all safety precautions.**
- f. **Remove CPG auxiliary panel (1) from console (2).**
  - (1) Unlock four turnlock fasteners (3).
  - (2) Remove panel (1) from console (2).

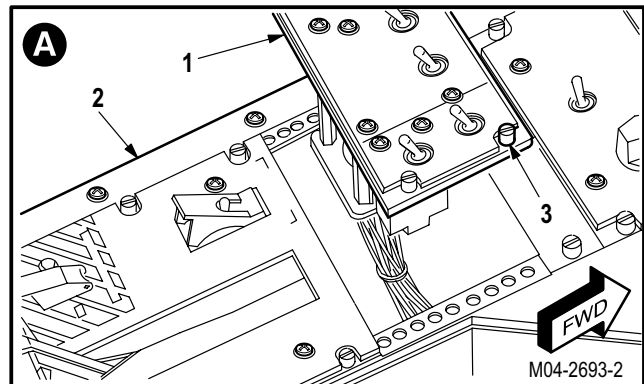
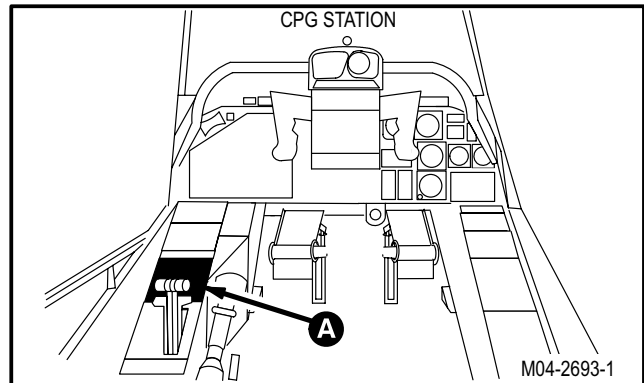

GO TO NEXT PAGE

**12.53. CPG AUXILIARY PANEL ASSEMBLY REMOVAL/INSTALLATION - continued**

- g. **Detach connector P762 (5) from receptacle (A417)J1 (4).**

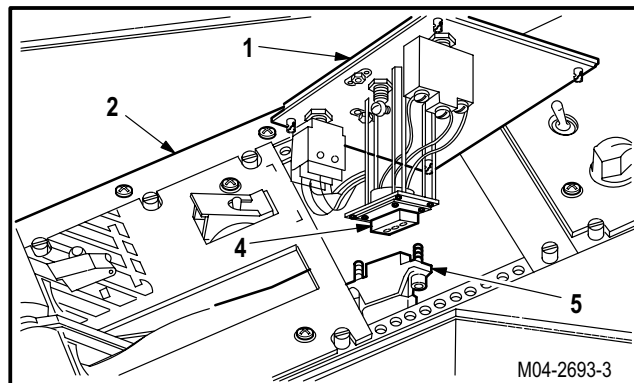

12.53.4. Cleaning

- a. **Wipe removed and attaching parts with a clean rag.**

12.53.5. Inspection

- a. **Check panel for nicks, dents, or cracks (para 12.46).**
- b. **Check connector for loose or bent pins (para 12.46).**
- c. **Check removed and attaching parts for corrosion (para 1.49).**

12.53.6. Installation

- a. **Attach connector P762 (5) to receptacle (A417)J1 (4).**

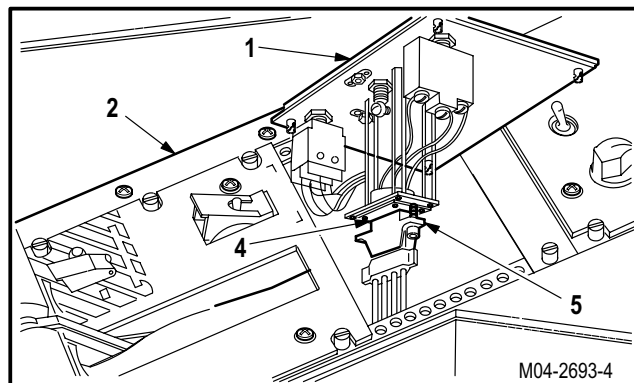

- b. **Install panel (1) on console (2).**
  - (1) Position panel (1) on console (2).
  - (2) Lock four turnlock fasteners (3).

- c. **Inspect (QA).**
- d. **Perform ECS, windshield wipers, and canopy defog and anti-ice maintenance operational checks (TM 1-1520-238-T).**

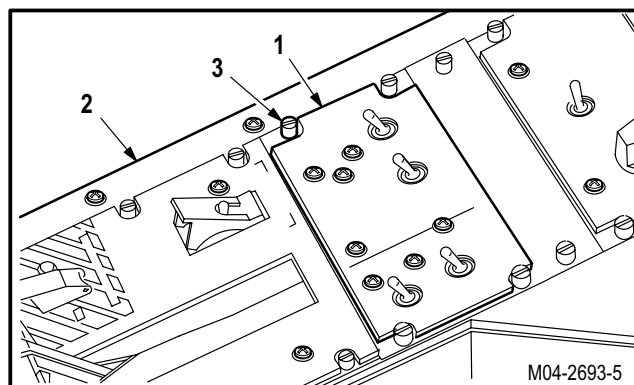

END OF TASK

---

## 12.54. CPG AUXILIARY PANEL LIGHT INDICATING PANEL REMOVAL/INSTALLATION

---

### 12.54.1. Description

This task covers: Removal. Cleaning. Inspection. Installation.

---

### 12.54.2. Initial Setup

#### **Tools:**

Electrical tool kit (item 378, App H)

#### **References:**

TM 1-1520-238-T

#### **Personnel Required:**

68X Armament/Electrical System Repairer  
68X3F Armament/Electrical System Repairer/  
Technical Inspector

#### **Equipment Conditions:**

<u>Ref</u>	<u>Condition</u>
1.57	Helicopter safed

---

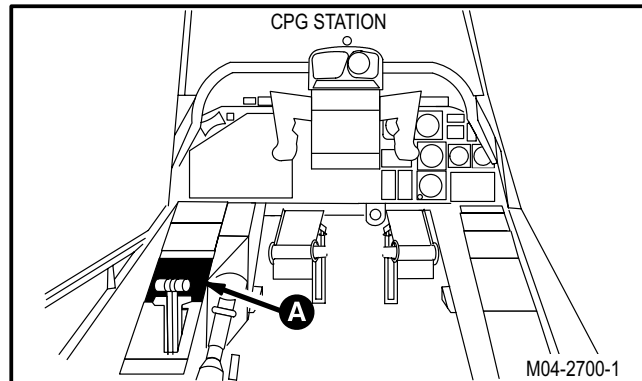

GO TO NEXT PAGE

---

**12.54. CPG AUXILIARY PANEL LIGHT INDICATING PANEL REMOVAL/INSTALLATION - continued**

---

12.54.3. Removal

- a. **Remove light indicating panel (1) from support panel (2).**

(1) Remove four screws (3).

(2) Remove panel (1).

12.54.4. Cleaning

- a. **Wipe removed and attaching parts with a clean rag.**

12.54.5. Inspection

- a. **Check support panel for nicks, dents, or cracks** (para 12.46).
- b. **Check removed and attaching parts for corrosion** (para 1.49).

12.54.6. Installation

- a. **Install panel (1) on panel (2).**

(1) Position panel (1) on panel (2).

(2) Install four screws (3).

- b. **Inspect (QA).**

- c. **Perform CPG edge-lights maintenance operational check** (TM 1-1520-238-T).

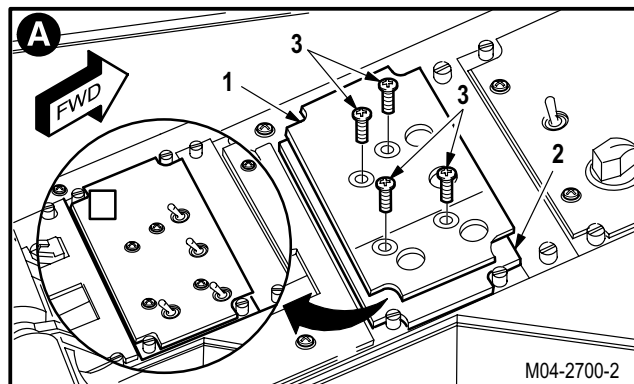

END OF TASK

---

## 12.55. BLADE DE-ICE CONTROLLER REMOVAL/INSTALLATION

---

### 12.55.1. Description

This task covers: Removal. Cleaning. Inspection. Installation.

---

### 12.55.2. Initial Setup

#### Tools:

Electrical tool kit (item 378, App H)  
Light duty laboratory apron (item 27, App H)  
Chemical protective gloves (item 154, App H)  
Ohmmeter (item 218, App H)  
Adjustable air filtering respirator (item 262, App H)

#### Materials/Parts:

Brush (item 34, App F)  
Sealing compound (item 175, App F)

#### Personnel Required:

68X Armament/Electrical System Repairer  
68X3F Armament/Electrical System Repairer/  
Technical Inspector

#### References:

TM 55-1500-323-24

#### Equipment Conditions:

<u>Ref</u>	<u>Condition</u>
1.57	Helicopter safed
2.2	Access panel R200 removed

---

### 12.55.3. Removal

- Enter pilot station (para 1.56). Observe all safety precautions.**
- On pilot forward circuit breaker panel, open AIR DATA AC circuit breaker.**
- On pilot center circuit breaker panel, open PI-TOT HTR and LT PRI circuit breakers.**
- On pilot aft circuit breaker panel, open ECS WSHLD WPR, CANOPY ANTI-ICE CONTR, ENG ANTI-ICE, and BLADE DE-ICE circuit breakers.**

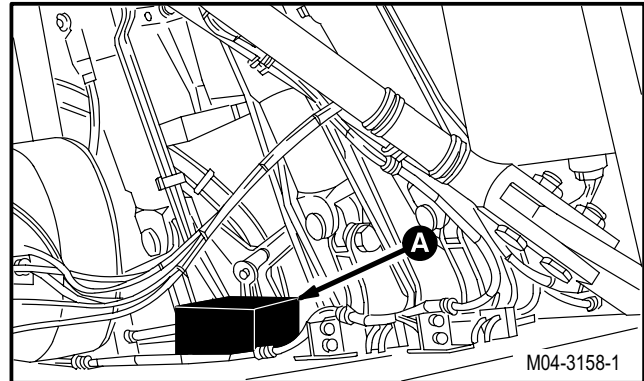

GO TO NEXT PAGE



---

**12.55. BLADE DE-ICE CONTROLLER REMOVAL/INSTALLATION - continued**

---

**e. Remove blade de-ice controller (1) from transmission deck (2).**

- (1) Detach connector P791 (3) from receptacle (A311)J1 (4).
- (2) Detach connector P792 (5) from receptacle (A311)J2 (6).
- (3) Remove four screws (7) and washers (8).
- (4) Remove controller (1).

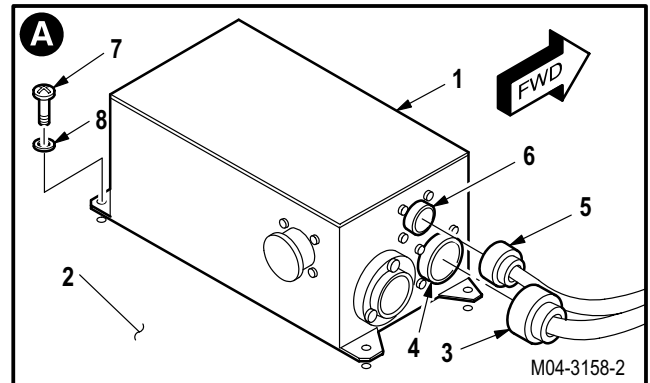
**12.55.4. Cleaning**

- a. **Clean removed and attaching parts** (para 1.47).

**12.55.5. Inspection**

- a. **Check mounting area of controller for cracks** (para 12.46).
- b. **Check removed and attaching parts for corrosion** (para 1.49).

GO TO NEXT PAGE

**12.55. BLADE DE-ICE CONTROLLER REMOVAL/INSTALLATION - continued**

12.55.6. Installation

**a. Install controller (1) on transmission deck (2).**

- (1) Position controller (1) with receptacle (A311)J1 (4) and receptacle (A311)J2 (6) facing outboard.
- (2) Install four screws (7) and washers (8).
- (3) Attach connector P791 (3) to receptacle (A311)J1 (4).
- (4) Attach connector P792 (5) to receptacle (A311)J2 (6).

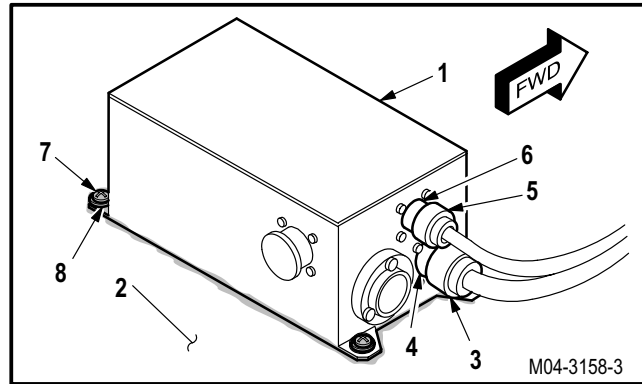

**b. Perform electrical bond check on controller (1) (TM 55-1500-323-24).**

- (1) Bond shall be **0.0025 OHM** or less. Use ohmmeter.



**c. Apply sealing compound around edges of controller mating surfaces and screw heads.**

Use sealing compound (item 175, App F) and brush (item 34, App F).

**d. Inspect (QA).**

**NOTE**

If TB 1-1520-238-20-62 (Deactivation of Main Rotor and Tail Rotor Blade De-ice Capability) is complied with, do not perform step e. Go to step f.

**e. Perform blade de-ice controller adjustment (para 12.56).**

**f. Install access panel R200 (para 2.2).**

END OF TASK

**12.56. BLADE DE-ICE CONTROLLER ADJUSTMENT**

12.56.1. Description

This task covers: Main Rotor Resistance Measurement. Tail Rotor Resistance Measurement. Adjustment Resistance Determination. Calibration Module Adjustment.

12.56.2. Initial Setup

**Tools:**

Electrical tool kit (item 378, App H)  
 Test adapter (item 10, App H)  
 Multimeter (item 215, App H)  
 Ohmmeter (item 218, App H)  
 Temperature probe thermal resistor (item 261, App H)

**Personnel Required:**

68X Armament/Electrical System Repairer  
 68X3F Armament/Electrical System Repairer/  
 Technical Inspector

**References:**

TM 1-1520-238-T

**Equipment Conditions:**

**Materials/Parts:**

Wire (item 222, App F)

<u>Ref</u>	<u>Condition</u>
1.57	Helicopter safed
2.2	Access panel R200 removed

**CAUTION**

- Temperature and resistance measurements are performed in a stable temperature environment with blade temperature as close as possible to air temperature to ensure proper system calibration. Ensure that blades are not heated or cooled by any energy source during this maintenance. Failure to maintain stable blade temperature will cause an improper system adjustment.
- Do not operate blade de-ice system with rotor blade erosion strips installed. Failure to do so could result in damage to rotor blades.

**NOTE**

- If TB 1-1520-238-20-62 (Deactivation of Main Rotor and Tail Rotor Blade De-ice Capability) is complied with, this task is not required.
- This task is not required if reinstalling the exact same controller or blade(s) in the exact same location(s) as a result of performing other maintenance. If controller or blade(s) have been replaced, perform this task.
- This task may be used to adjust one controller calibration module when changing one blade, or for adjusting all calibration modules when changing controller.
- Main rotor blades are identified by the power distributor connector number (P1 = Blade 1; P2 = Blade 2; etc.).

GO TO NEXT PAGE

**12.56. BLADE DE-ICE CONTROLLER ADJUSTMENT - continued**

12.56.3. Main Rotor Resistance Measurement

- a. **Enter pilot station** (para 1.56). **Observe all safety precautions.**
- b. **On pilot aft circuit breaker panel, open ECS ICE DET, BLADE DE-ICE, and BLADE DE-ICE CONTR circuit breakers.**

c. **Measure air and main rotor blade (1) temperature.**

- (1) Measure and record air temperature in degrees Celsius. Use multimeter and probe.
- (2) Measure and record rotor blade (1) surface temperature at upper leading edge (2) of blade root. Use multimeter and probe. Press probe on root fitting and wait until reading stabilizes.
- (3) Repeat steps c.(1) and c.(2) if difference between blade (1) temperature and air temperature is greater than 2 °C.
- (4) Record blade (1) temperature if value determined in step c.(3) is less than 2 °C. Use nearest whole number.

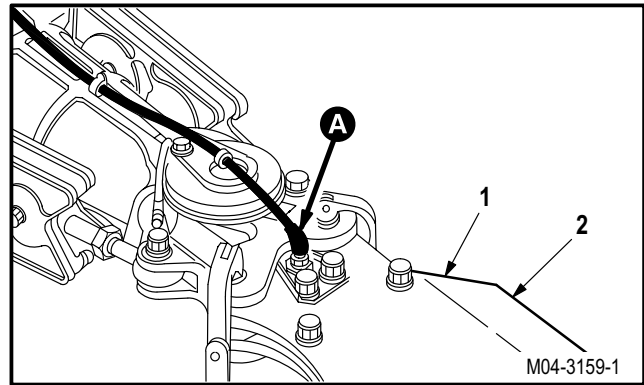

d. **Install calibration test adapter (3) on rotor blade (1).**

- (1) Record rotor blade (1) serial number and de-ice power connector (4) number.
- (2) Remove lockwire between de-ice power connector (4) and blade heater element receptacle J1 (5).
- (3) Detach de-ice power connector (4) from blade heater element receptacle J1 (5).
- (4) Attach calibration test adapter (3) connector P1 (6) to blade heater element receptacle J1 (5).

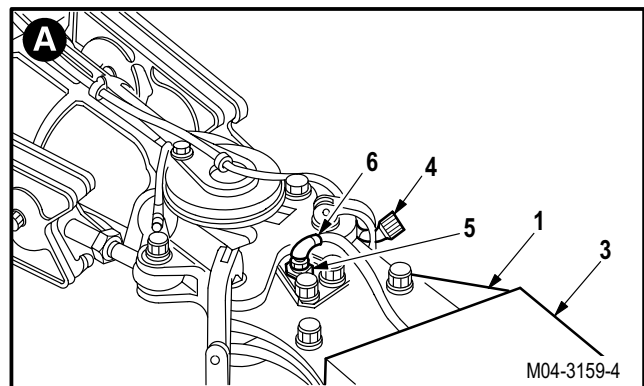

GO TO NEXT PAGE

**12.56. BLADE DE-ICE CONTROLLER ADJUSTMENT - continued****e. Perform main blade heater element resistance measurements.**

- (1) Measure and record resistance for five blade heater elements between adapter test points (7). Measure values to the nearest **10 MILIOHMS**. Use ohmmeter.

Measure Between Test Points

TP1 to TP5  
 TP2 to TP5  
 TP3 to TP5  
 TP4 to TP5  
 TP6 to TP5

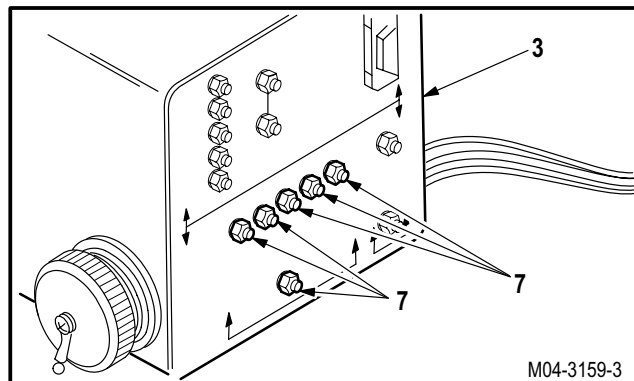
**f. Remove calibration test adapter (3) from rotor blade (1).**

- (1) Detach calibration test adapter (3) connector P1 (6) from blade heater receptacle J1 (5).
- (2) Attach de-ice power connector (4) to blade heater receptacle J1 (5).
- (3) Lockwire connector (4) and receptacle (5) together. Use wire (item 222, App F).

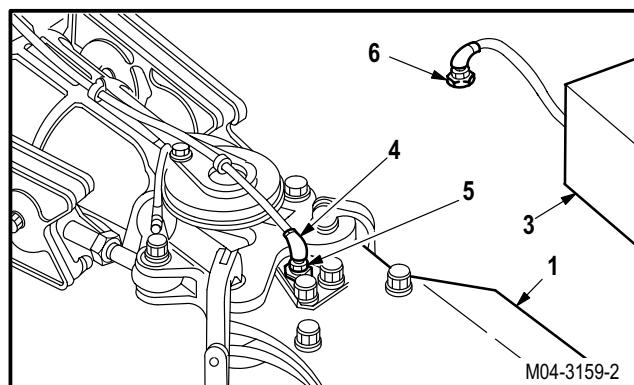
**g. Repeat steps c. thru f. for each remaining blade (1).**

GO TO NEXT PAGE

**12.56. BLADE DE-ICE CONTROLLER ADJUSTMENT - continued**

12.56.4. Tail Rotor Resistance Measurement

**a. Measure air and tail rotor blade (9) temperature.**

- (1) Verify tail rotor heating connectors P999, P1034, P1035, and P1036 (8) are attached and lockwired to corresponding tail rotor blades (9).
- (2) Measure and record air temperature in degrees Celsius. Use multimeter and probe.
- (3) Measure and record temperature of tail rotor blade (9) at root fitting (10). Use multimeter and probe. Press probe on root fitting (10) and wait until reading stabilizes.
- (4) Repeat steps a.(2) and a.(3) if difference between blade (9) temperature and air temperature is greater than 2 °C.
- (5) Record blade (9) temperature if value determined in step a.(4) is less than 2 °C. Use nearest whole number.

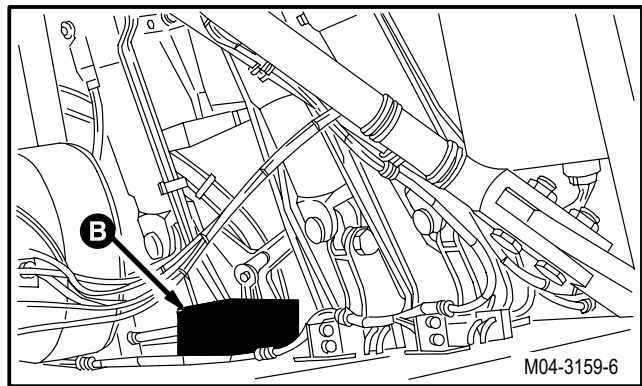
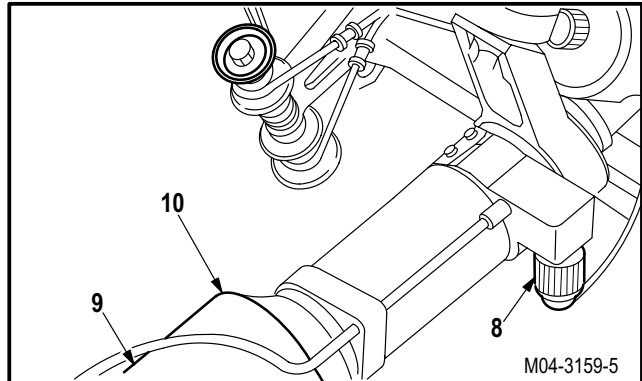

**b. Detach connector P791 (11) from receptacle (A311)J1 (12) on de-ice controller (13).**

**c. Attach connector P791 (11) to calibration test adapter (3) receptacle J1 (14).**

**d. Perform tail blade heater element resistance measurements.**

- (1) Measure and record resistance for tail rotor heater elements between test points TP-G (15) and TP-F (16) on calibration test adapter (3). Measure value to nearest 10 milliohms. Use ohmmeter.

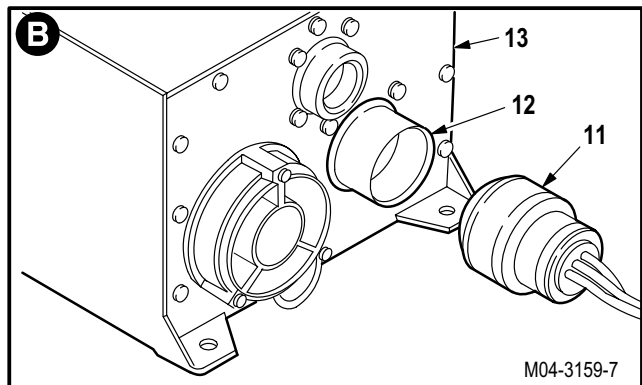

**e. Detach connector P791 (11) from calibration test adapter (3) receptacle J1 (14).**

**f. Attach connector P791 (11) to receptacle (A311)J1 (12) on de-ice controller (13).**

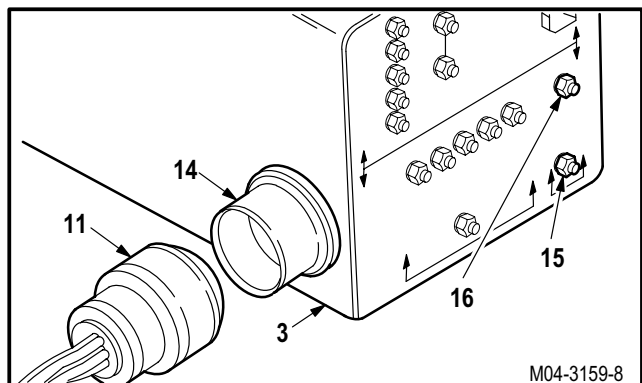

GO TO NEXT PAGE







**12.56. BLADE DE-ICE CONTROLLER ADJUSTMENT - continued**

12.56.6. Calibration Module Adjustment

**NOTE**

The following relationship exists between calibration modules and main and tail rotor blades:

<u>Calibration Module</u>	<u>Rotor Blade</u>
P10	Tail Rotor Blade
P11	Main Rotor P1
P12	Main Rotor P2
P13	Main Rotor P3
P14	Main Rotor P4

- a. Remove calibration module (17) to be adjusted from de-ice controller (13).
- b. Install module (17) in calibration test adapter (3) receptacle J2 (18).

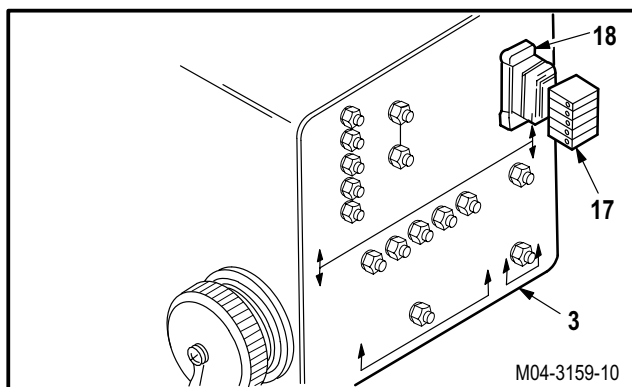
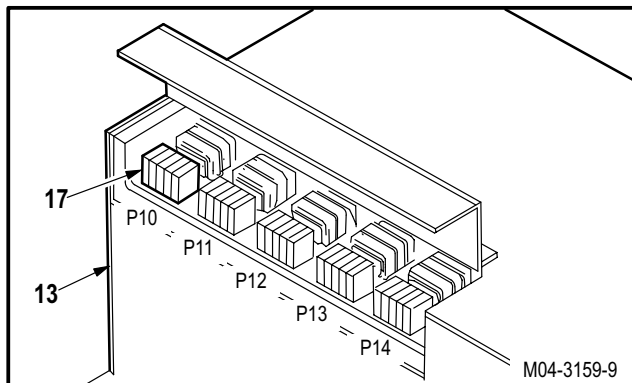

**NOTE**

- Each main rotor blade calibration module contains five variable resistors which must be set to resistances determined, using Table I. Tail rotor blade calibration module contains a single variable resistor which is set, using Table II. Calibration module adjustment is typical except for number of resistors.
- The following relationships exist between main rotor heater element test points, calibration module variable resistors, and module resistor test points:

<u>Heater Element Test Points</u>	<u>Variable Resistors</u>	<u>Module Resistor Test Points</u>
TP1 - TP5	R1	TP - R1
TP2 - TP5	R2	TP - R2
TP3 - TP5	R3	TP - R3
TP4 - TP5	R4	TP - R4
TP6 - TP5	R5	TP - R5

GO TO NEXT PAGE

**12.56. BLADE DE-ICE CONTROLLER ADJUSTMENT - continued**

**c. Adjust calibration module (17).**

- (1) Remove and retain adhesive tape covering five variable resistors (19) on module (17).
- (2) Measure resistance between appropriate module resistor test point (20) and common test point (21) on calibration test adapter (3). Use ohmmeter.
- (3) Adjust resistors (19) on module (17) to resistances determined, using Table I or II. Adjustment accuracy of  $\pm 10$  OHMS is acceptable.
- (4) Replace adhesive tape over resistors (19) on module (17).

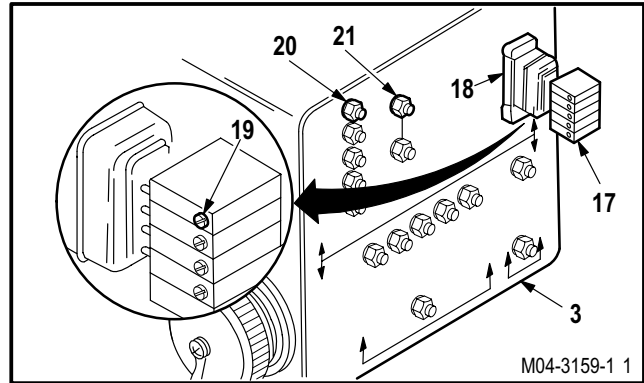

**d. Install module (17) in de-ice controller (13).**

- (1) Remove module (17) from calibration test adapter (3) receptacle J2 (18).
- (2) Install module (17) in de-ice controller (13).

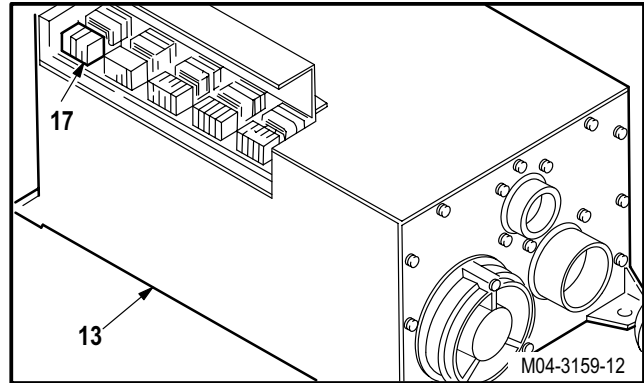

**e. Repeat steps a. thru d. for all calibration modules (17).**

**f. Inspect (QA).**

**g. Perform rotor blades de-ice maintenance operational check (TM 1-1520-238-T).**

**h. Install access panel R200 (para 2.2).**

GO TO NEXT PAGE

12.56. BLADE DE-ICE CONTROLLER ADJUSTMENT - continued

TABLE I. MAIN ROTOR BLADE ADJUSTMENT CHARTS

Blade Temp. (°C)	Main Rotor Adjustment Resistance (kiloohm)								
	10.08	10.09	10.10	10.11	10.12	10.13	10.14	10.15	10.16
50.									
49.									
48.									
47.									
46.									
45.									
44.									
43.									
42.									
41.									
40.									
39.									
38.									
37.									
36.									
35.									
34.									
33.									
32.									
31.									
30.									
29.									
28.									
27.									
26.									
25.									
24.									
23.									
22.									
21.									
20.									
19.									
18.									
17.									
16.									
15.									
14.									
13.									
12.									
11.									
10.									
9.									
8.									
7.									
6.									
5.									
4.									
3.									
2.									
1.									
0.									
-1.									
-2.									
-3.									
-4.									
-5.									
-6.									
-7.									
-8.									
-9.									
-10.									
-11.									
-12.									
-13.									
-14.									
-15.									
-16.							0.01	0.00	0.02
-17.						0.03	0.05	0.07	0.09
-18.				0.02	0.04	0.06	0.08	0.11	0.13
-19.		0.01	0.03	0.05	0.08	0.10	0.12	0.14	0.17
-20.	0.02	0.04	0.07	0.09	0.11	0.13	0.16	0.18	0.20

Heater Resistance (Ohm) ----->

GO TO NEXT PAGE

12.56. BLADE DE-ICE CONTROLLER ADJUSTMENT - continued

**TABLE I. MAIN ROTOR BLADE ADJUSTMENT CHARTS (cont)**

Blade Temp. (°C)	Main Rotor Adjustment Resistance (kiloohm)									
	10.17	10.18	10.19	10.20	10.21	10.22	10.23	10.24	10.25	
50.										
49.										
48.										
47.										
46.										
45.										
44.										
43.										
42.										
41.										
40.										
39.										
38.										
37.										
36.										
35.										
34.										
33.										
32.										
31.										
30.										
29.										
28.										
27.										
26.										
25.										
24.										
23.										
22.										
21.										
20.										
19.										
18.										
17.										
16.										
15.										
14.										
13.										
12.										
11.										
10.										
9.										
8.										
7.										
6.										
5.										
4.										
3.										
2.										
1.										
0.										
-1.										
-2.										
-3.										
-4.										
-5.										
-6.										
-7.										
-8.										
-9.										0.01
-10.							0.00	0.02		0.04
-11.						0.01	0.04	0.06		0.08
-12.				0.00	0.03	0.05	0.07	0.09		0.12
-13.			0.02	0.04	0.06	0.08	0.11	0.13		0.15
-14.	0.01	0.03	0.05	0.08	0.10	0.12	0.14	0.16		0.19
-15.	0.04	0.07	0.09	0.11	0.13	0.16	0.18	0.20		0.22
-16.	0.08	0.10	0.12	0.15	0.17	0.19	0.21	0.24		0.26
-17.	0.12	0.14	0.16	0.18	0.21	0.23	0.25	0.27		0.29
-18.	0.15	0.17	0.20	0.22	0.24	0.26	0.29	0.31		0.33
-19.	0.19	0.21	0.23	0.25	0.28	0.30	0.32	0.34		0.37
-20.	0.22	0.25	0.27	0.29	0.31	0.34	0.36	0.38		0.40
	10.17	10.18	10.19	10.20	10.21	10.22	10.23	10.24	10.25	

Heater Resistance (Ohm) ----->

GO TO NEXT PAGE

12.56. BLADE DE-ICE CONTROLLER ADJUSTMENT - continued

**TABLE I. MAIN ROTOR BLADE ADJUSTMENT CHARTS (cont)**

Blade Temp. (°C)	Main Rotor Adjustment Resistance (kiloohm)								
	10.26	10.27	10.28	10.29	10.30	10.31	10.32	10.33	10.34
50.									
49.									
48.									
47.									
46.									
45.									
44.									
43.									
42.									
41.									
40.									
39.									
38.									
37.									
36.									
35.									
34.									
33.									
32.									
31.									
30.									
29.									
28.									
27.									
26.									
25.									
24.									
23.									
22.									
21.									
20.									
19.									
18.									
17.									
16.									
15.									
14.									
13.									
12.									
11.									
10.									
9.									
8.									
7.									
6.									
5.									
4.									
3.									
2.									
1.									
0.									
-1.									
-2.									
-3.									
-4.								0.01	0.03
-5.						0.00	0.02	0.04	0.07
-6.					0.01	0.04	0.06	0.08	0.10
-7.			0.00	0.03	0.05	0.07	0.09	0.11	0.14
-8.		0.02	0.04	0.06	0.08	0.11	0.13	0.15	0.17
-9.	0.03	0.05	0.07	0.10	0.12	0.14	0.16	0.18	0.21
-10.	0.07	0.09	0.11	0.13	0.15	0.18	0.20	0.22	0.24
-11.	0.10	0.12	0.15	0.17	0.19	0.21	0.23	0.26	0.28
-12.	0.14	0.16	0.18	0.20	0.23	0.25	0.27	0.29	0.31
-13.	0.17	0.19	0.22	0.24	0.26	0.28	0.31	0.33	0.35
-14.	0.21	0.23	0.25	0.28	0.30	0.32	0.34	0.36	0.39
-15.	0.24	0.27	0.29	0.31	0.33	0.36	0.38	0.40	0.42
-16.	0.28	0.30	0.32	0.35	0.37	0.39	0.41	0.44	0.46
-17.	0.32	0.34	0.36	0.38	0.41	0.43	0.45	0.47	0.49
-18.	0.35	0.37	0.40	0.42	0.44	0.46	0.49	0.51	0.53
-19.	0.39	0.41	0.43	0.46	0.48	0.50	0.52	0.55	0.57
-20.	0.43	0.45	0.47	0.49	0.51	0.54	0.56	0.58	0.60

GO TO NEXT PAGE

12.56. BLADE DE-ICE CONTROLLER ADJUSTMENT - continued

TABLE I. MAIN ROTOR BLADE ADJUSTMENT CHARTS (cont)

Blade Temp. (°C)	Main Rotor Adjustment Resistance (kiloohm)									
	10.35	10.36	10.37	10.38	10.39	10.40	10.41	10.42	10.43	
50.										
49.										
48.										
47.										
46.										
45.										
44.										
43.										
42.										
41.										
40.										
39.										
38.										
37.										
36.										
35.										
34.										
33.										
32.										
31.										
30.										
29.										
28.										
27.										
26.										
25.										
24.										
23.										
22.										
21.										
20.										
19.										
18.										
17.										
16.										
15.										
14.										
13.										
12.										
11.										
10.										
9.										
8.										
7.										
6.										
5.										
4.										
3.										
2.										0.02
1.							0.01	0.03		0.05
0.					0.00	0.02	0.04	0.07	0.09	0.12
-1.				0.01	0.03	0.06	0.08	0.10	0.13	0.16
-2.		0.00	0.03	0.05	0.07	0.09	0.11	0.13	0.16	0.19
-3.	0.02	0.04	0.06	0.08	0.10	0.13	0.15	0.17	0.19	0.23
-4.	0.05	0.07	0.10	0.12	0.14	0.16	0.18	0.21	0.23	0.26
-5.	0.09	0.11	0.13	0.15	0.17	0.20	0.22	0.24	0.26	0.30
-6.	0.12	0.14	0.17	0.19	0.21	0.23	0.25	0.28	0.30	0.33
-7.	0.16	0.18	0.20	0.22	0.25	0.27	0.29	0.31	0.33	0.37
-8.	0.19	0.22	0.24	0.26	0.28	0.30	0.33	0.35	0.37	0.40
-9.	0.23	0.25	0.27	0.29	0.32	0.34	0.36	0.38	0.40	0.44
-10.	0.26	0.29	0.31	0.33	0.35	0.37	0.40	0.42	0.44	0.48
-11.	0.30	0.32	0.34	0.37	0.39	0.41	0.43	0.45	0.48	0.51
-12.	0.34	0.36	0.38	0.40	0.42	0.45	0.47	0.49	0.51	0.55
-13.	0.37	0.39	0.42	0.44	0.46	0.48	0.50	0.53	0.55	0.59
-14.	0.41	0.43	0.45	0.47	0.50	0.52	0.54	0.56	0.59	0.62
-15.	0.44	0.47	0.49	0.51	0.53	0.56	0.58	0.60	0.62	0.66
-16.	0.48	0.50	0.52	0.55	0.57	0.59	0.61	0.64	0.66	0.70
-17.	0.52	0.54	0.56	0.58	0.61	0.63	0.65	0.67	0.70	0.73
-18.	0.55	0.58	0.60	0.62	0.64	0.67	0.69	0.71	0.73	0.77
-19.	0.59	0.61	0.63	0.66	0.68	0.70	0.72	0.75	0.77	0.81
-20.	0.63	0.65	0.67	0.69	0.72	0.74	0.76	0.78	0.81	
	10.35	10.36	10.37	10.38	10.39	10.40	10.41	10.42	10.43	
	Heater Resistance (Ohm) ----->									

GO TO NEXT PAGE

12.56. BLADE DE-ICE CONTROLLER ADJUSTMENT - continued

**TABLE I. MAIN ROTOR BLADE ADJUSTMENT CHARTS (cont)**

Blade Temp. (°C)	Main Rotor Adjustment Resistance (kiloohm)								
	10.44	10.45	10.46	10.47	10.48	10.49	10.50	10.51	10.52
50.									
49.									
48.									
47.									
46.									
45.									
44.									
43.									
42.									
41.									
40.									
39.									
38.									
37.									
36.									
35.									
34.									
33.									
32.									
31.									
30.									
29.									
28.									
27.									
26.									
25.									
24.									
23.									
22.									
21.									
20.									
19.									
18.									
17.									
16.									
15.									
14.									
13.									
12.									
11.									
10.									
9.									
8.									0.00
7.								0.02	0.04
6.						0.01	0.03	0.05	0.07
5.				0.00	0.02	0.04	0.06	0.09	0.11
4.			0.01	0.03	0.06	0.08	0.10	0.12	0.14
3.	0.00	0.03	0.05	0.07	0.09	0.11	0.13	0.16	0.18
2.	0.04	0.06	0.08	0.10	0.13	0.15	0.17	0.19	0.21
1.	0.07	0.10	0.12	0.14	0.16	0.18	0.20	0.23	0.25
0.	0.11	0.13	0.15	0.17	0.20	0.22	0.24	0.26	0.28
-1.	0.14	0.17	0.19	0.21	0.23	0.25	0.27	0.30	0.32
-2.	0.18	0.20	0.22	0.24	0.27	0.29	0.31	0.33	0.35
-3.	0.21	0.24	0.26	0.28	0.30	0.32	0.34	0.37	0.39
-4.	0.25	0.27	0.29	0.31	0.34	0.36	0.38	0.40	0.42
-5.	0.28	0.31	0.33	0.35	0.37	0.39	0.42	0.44	0.46
-6.	0.32	0.34	0.36	0.39	0.41	0.43	0.45	0.47	0.49
-7.	0.36	0.38	0.40	0.42	0.44	0.46	0.49	0.51	0.53
-8.	0.39	0.41	0.43	0.46	0.48	0.50	0.52	0.54	0.57
-9.	0.43	0.45	0.47	0.49	0.51	0.54	0.56	0.58	0.60
-10.	0.46	0.48	0.51	0.53	0.55	0.57	0.59	0.62	0.64
-11.	0.50	0.52	0.54	0.57	0.59	0.61	0.63	0.65	0.68
-12.	0.53	0.56	0.58	0.60	0.62	0.65	0.67	0.69	0.71
-13.	0.57	0.59	0.62	0.64	0.66	0.68	0.70	0.73	0.75
-14.	0.61	0.63	0.65	0.67	0.70	0.72	0.74	0.76	0.78
-15.	0.64	0.67	0.69	0.71	0.73	0.76	0.78	0.80	0.82
-16.	0.68	0.70	0.73	0.75	0.77	0.79	0.81	0.84	0.86
-17.	0.72	0.74	0.76	0.78	0.81	0.83	0.85	0.87	0.90
-18.	0.75	0.78	0.80	0.82	0.84	0.87	0.89	0.91	0.93
-19.	0.79	0.81	0.84	0.86	0.88	0.90	0.93	0.95	0.97
-20.	0.83	0.85	0.87	0.90	0.92	0.94	0.96	0.98	1.01
	10.44	10.45	10.46	10.47	10.48	10.49	10.50	10.51	10.52
	Heater Resistance (Ohm) ----->								

GO TO NEXT PAGE

12.56. BLADE DE-ICE CONTROLLER ADJUSTMENT - continued

TABLE I. MAIN ROTOR BLADE ADJUSTMENT CHARTS (cont)

Blade Temp. (°C)	Main Rotor Adjustment Resistance (kiloohm)									
	10.53	10.54	10.55	10.56	10.57	10.58	10.59	10.60	10.61	
50.										
49.										
48.										
47.										
46.										
45.										
44.										
43.										
42.										
41.										
40.										
39.										
38.										
37.										
36.										
35.										
34.										
33.										
32.										
31.										
30.										
29.										
28.										
27.										
26.										
25.										
24.										
23.										
22.										
21.										
20.										
19.										
18.										
17.										
16.										
15.										
14.										
13.								0.00	0.03	
12.							0.02	0.04	0.06	
11.					0.01	0.03	0.05	0.07	0.09	
10.			0.00	0.02	0.04	0.06	0.09	0.11	0.13	
9.		0.01	0.03	0.06	0.08	0.10	0.12	0.14	0.16	
8.	0.03	0.05	0.07	0.09	0.11	0.13	0.15	0.18	0.20	
7.	0.06	0.08	0.10	0.12	0.15	0.17	0.19	0.21	0.23	
6.	0.09	0.12	0.14	0.16	0.18	0.20	0.22	0.25	0.27	
5.	0.13	0.15	0.17	0.19	0.22	0.24	0.26	0.28	0.30	
4.	0.16	0.19	0.21	0.23	0.25	0.27	0.29	0.31	0.34	
3.	0.20	0.22	0.24	0.26	0.29	0.31	0.33	0.35	0.37	
2.	0.23	0.26	0.28	0.30	0.32	0.34	0.36	0.39	0.41	
1.	0.27	0.29	0.31	0.33	0.36	0.38	0.40	0.42	0.44	
0.	0.30	0.33	0.35	0.37	0.39	0.41	0.43	0.46	0.48	
-1.	0.34	0.36	0.38	0.40	0.43	0.45	0.47	0.49	0.51	
-2.	0.37	0.40	0.42	0.44	0.46	0.48	0.50	0.53	0.55	
-3.	0.41	0.43	0.45	0.48	0.50	0.52	0.54	0.56	0.58	
-4.	0.45	0.47	0.49	0.51	0.53	0.55	0.58	0.60	0.62	
-5.	0.48	0.50	0.52	0.55	0.57	0.59	0.61	0.63	0.66	
-6.	0.52	0.54	0.56	0.58	0.60	0.63	0.65	0.67	0.69	
-7.	0.55	0.57	0.60	0.62	0.64	0.66	0.68	0.71	0.73	
-8.	0.59	0.61	0.63	0.65	0.68	0.70	0.72	0.74	0.76	
-9.	0.62	0.65	0.67	0.69	0.71	0.73	0.76	0.78	0.80	
-10.	0.66	0.68	0.71	0.73	0.75	0.77	0.79	0.82	0.84	
-11.	0.70	0.72	0.74	0.76	0.79	0.81	0.83	0.85	0.87	
-12.	0.73	0.76	0.78	0.80	0.82	0.84	0.87	0.89	0.91	
-13.	0.77	0.79	0.81	0.84	0.86	0.88	0.90	0.93	0.95	
-14.	0.81	0.83	0.85	0.87	0.90	0.92	0.94	0.96	0.98	
-15.	0.84	0.87	0.89	0.91	0.93	0.95	0.98	1.00	1.02	
-16.	0.88	0.90	0.93	0.95	0.97	0.99	1.01	1.04	1.06	
-17.	0.92	0.94	0.96	0.98	1.01	1.03	1.05	1.07	1.10	
-18.	0.96	0.98	1.00	1.02	1.04	1.07	1.09	1.11	1.13	
-19.	0.99	1.01	1.04	1.06	1.08	1.10	1.13	1.15	1.17	
-20.	1.03	1.05	1.07	1.10	1.12	1.14	1.16	1.19	1.21	
	10.53	10.54	10.55	10.56	10.57	10.58	10.59	10.60	10.61	
	Heater Resistance (Ohm) ----->									

GO TO NEXT PAGE



12.56. BLADE DE-ICE CONTROLLER ADJUSTMENT - continued

TABLE I. MAIN ROTOR BLADE ADJUSTMENT CHARTS (cont)

Blade Temp. (°C)	Main Rotor Adjustment Resistance (kiloohm)								
	10.62	10.63	10.64	10.65	10.66	10.67	10.68	10.69	10.70
50.									
49.									
48.									
47.									
46.									
45.									
44.									
43.									
42.									
41.									
40.									
39.									
38.									
37.									
36.									
35.									
34.									
33.									
32.									
31.									
30.									
29.									
28.									
27.									
26.									
25.									
24.									
23.									
22.									
21.									
20.									
19.									0.01
18.							0.00	0.03	0.05
17.						0.02	0.04	0.06	0.08
16.				0.01	0.03	0.05	0.07	0.09	0.11
15.		0.00	0.02	0.04	0.06	0.08	0.11	0.13	0.15
14.	0.01	0.03	0.06	0.08	0.10	0.12	0.14	0.16	0.18
13.	0.05	0.07	0.09	0.11	0.13	0.15	0.17	0.20	0.22
12.	0.08	0.10	0.12	0.14	0.17	0.19	0.21	0.23	0.25
11.	0.12	0.14	0.16	0.18	0.20	0.22	0.24	0.26	0.29
10.	0.15	0.17	0.19	0.21	0.24	0.26	0.28	0.30	0.32
9.	0.18	0.21	0.23	0.25	0.27	0.29	0.31	0.33	0.36
8.	0.22	0.24	0.26	0.28	0.30	0.33	0.35	0.37	0.39
7.	0.25	0.27	0.30	0.32	0.34	0.36	0.38	0.40	0.42
6.	0.29	0.31	0.33	0.35	0.37	0.40	0.42	0.44	0.46
5.	0.32	0.34	0.37	0.39	0.41	0.43	0.45	0.47	0.50
4.	0.36	0.38	0.40	0.42	0.44	0.47	0.49	0.51	0.53
3.	0.39	0.41	0.44	0.46	0.48	0.50	0.52	0.54	0.57
2.	0.43	0.45	0.47	0.49	0.51	0.54	0.56	0.58	0.60
1.	0.46	0.49	0.51	0.53	0.55	0.57	0.59	0.62	0.64
0.	0.50	0.52	0.54	0.56	0.59	0.61	0.63	0.65	0.67
-1.	0.53	0.56	0.58	0.60	0.62	0.64	0.66	0.69	0.71
-2.	0.57	0.59	0.61	0.64	0.66	0.68	0.70	0.72	0.74
-3.	0.61	0.63	0.65	0.67	0.69	0.71	0.74	0.76	0.78
-4.	0.64	0.66	0.69	0.71	0.73	0.75	0.77	0.79	0.82
-5.	0.68	0.70	0.72	0.74	0.77	0.79	0.81	0.83	0.85
-6.	0.71	0.74	0.76	0.78	0.80	0.82	0.85	0.87	0.89
-7.	0.75	0.77	0.79	0.82	0.84	0.86	0.88	0.90	0.93
-8.	0.79	0.81	0.83	0.85	0.87	0.90	0.92	0.94	0.96
-9.	0.82	0.84	0.87	0.89	0.91	0.93	0.95	0.98	1.00
-10.	0.86	0.88	0.90	0.93	0.95	0.97	0.99	1.01	1.04
-11.	0.90	0.92	0.94	0.96	0.98	1.01	1.03	1.05	1.07
-12.	0.93	0.95	0.98	1.00	1.02	1.04	1.07	1.09	1.11
-13.	0.97	0.99	1.01	1.04	1.06	1.08	1.10	1.12	1.15
-14.	1.01	1.03	1.05	1.07	1.10	1.12	1.14	1.16	1.18
-15.	1.04	1.07	1.09	1.11	1.13	1.15	1.18	1.20	1.22
-16.	1.08	1.10	1.13	1.15	1.17	1.19	1.21	1.24	1.26
-17.	1.12	1.14	1.16	1.19	1.21	1.23	1.25	1.27	1.30
-18.	1.16	1.18	1.20	1.22	1.25	1.27	1.29	1.31	1.33
-19.	1.19	1.22	1.24	1.26	1.28	1.31	1.33	1.35	1.37
-20.	1.23	1.25	1.28	1.30	1.32	1.34	1.37	1.39	1.41
	10.62	10.63	10.64	10.65	10.66	10.67	10.68	10.69	10.70

Heater Resistance (Ohm) ----->

GO TO NEXT PAGE

12.56. BLADE DE-ICE CONTROLLER ADJUSTMENT - continued

TABLE I. MAIN ROTOR BLADE ADJUSTMENT CHARTS (cont)

Blade Temp. (°C)	Main Rotor Adjustment Resistance (kiloohm)									
	10.71	10.72	10.73	10.74	10.75	10.76	10.77	10.78	10.79	
50.										
49.										
48.										
47.										
46.										
45.										
44.										
43.										
42.										
41.										
40.										
39.										
38.										
37.										
36.										
35.										
34.										
33.										
32.										
31.										
30.										
29.										
28.										
27.										
26.										
25.										
24.								0.01	0.03	
23.						0.00	0.03	0.05	0.07	
22.					0.02	0.04	0.06	0.08	0.10	
21.			0.01	0.03	0.05	0.07	0.09	0.11	0.13	
20.	0.00	0.02	0.04	0.06	0.08	0.11	0.13	0.15	0.17	
19.	0.03	0.05	0.08	0.10	0.12	0.14	0.16	0.18	0.20	
18.	0.07	0.09	0.11	0.13	0.15	0.17	0.19	0.22	0.24	
17.	0.10	0.12	0.14	0.16	0.19	0.21	0.23	0.25	0.27	
16.	0.14	0.16	0.18	0.20	0.22	0.24	0.26	0.28	0.30	
15.	0.17	0.19	0.21	0.23	0.25	0.28	0.30	0.32	0.34	
14.	0.20	0.23	0.25	0.27	0.29	0.31	0.33	0.35	0.37	
13.	0.24	0.26	0.28	0.30	0.32	0.34	0.37	0.39	0.41	
12.	0.27	0.29	0.32	0.34	0.36	0.38	0.40	0.42	0.44	
11.	0.31	0.33	0.35	0.37	0.39	0.41	0.44	0.46	0.48	
10.	0.34	0.36	0.38	0.41	0.43	0.45	0.47	0.49	0.51	
9.	0.38	0.40	0.42	0.44	0.46	0.48	0.50	0.53	0.55	
8.	0.41	0.43	0.45	0.48	0.50	0.52	0.54	0.56	0.58	
7.	0.45	0.47	0.49	0.51	0.53	0.55	0.58	0.60	0.62	
6.	0.48	0.50	0.52	0.55	0.57	0.59	0.61	0.63	0.65	
5.	0.52	0.54	0.56	0.58	0.60	0.62	0.65	0.67	0.69	
4.	0.55	0.57	0.60	0.62	0.64	0.66	0.68	0.70	0.72	
3.	0.59	0.61	0.63	0.65	0.67	0.70	0.72	0.74	0.76	
2.	0.62	0.64	0.67	0.69	0.71	0.73	0.75	0.77	0.80	
1.	0.66	0.68	0.70	0.72	0.75	0.77	0.79	0.81	0.83	
0.	0.69	0.72	0.74	0.76	0.78	0.80	0.82	0.85	0.87	
-1.	0.73	0.75	0.77	0.80	0.82	0.84	0.86	0.88	0.90	
-2.	0.77	0.79	0.81	0.83	0.85	0.87	0.90	0.92	0.94	
-3.	0.80	0.82	0.85	0.87	0.89	0.91	0.93	0.95	0.98	
-4.	0.84	0.86	0.88	0.90	0.93	0.95	0.97	0.99	1.01	
-5.	0.87	0.90	0.92	0.94	0.96	0.98	1.01	1.03	1.05	
-6.	0.91	0.93	0.95	0.98	1.00	1.02	1.04	1.06	1.09	
-7.	0.95	0.97	0.99	1.01	1.04	1.06	1.08	1.10	1.12	
-8.	0.98	1.01	1.03	1.05	1.07	1.09	1.12	1.14	1.16	
-9.	1.02	1.04	1.06	1.09	1.11	1.13	1.15	1.17	1.20	
-10.	1.06	1.08	1.10	1.12	1.15	1.17	1.19	1.21	1.23	
-11.	1.09	1.12	1.14	1.16	1.18	1.20	1.23	1.25	1.27	
-12.	1.13	1.15	1.18	1.20	1.22	1.24	1.26	1.29	1.31	
-13.	1.17	1.19	1.21	1.24	1.26	1.28	1.30	1.32	1.35	
-14.	1.21	1.23	1.25	1.27	1.29	1.32	1.34	1.36	1.38	
-15.	1.24	1.27	1.29	1.31	1.33	1.35	1.38	1.40	1.42	
-16.	1.28	1.30	1.33	1.35	1.37	1.39	1.41	1.44	1.46	
-17.	1.32	1.34	1.36	1.39	1.41	1.43	1.45	1.47	1.50	
-18.	1.36	1.38	1.40	1.42	1.45	1.47	1.49	1.51	1.54	
-19.	1.39	1.42	1.44	1.46	1.48	1.51	1.53	1.55	1.57	
-20.	1.43	1.45	1.48	1.50	1.52	1.54	1.57	1.59	1.61	
	10.71	10.72	10.73	10.74	10.75	10.76	10.77	10.78	10.79	
	Heater Resistance (Ohm) ----->									

GO TO NEXT PAGE

12.56. BLADE DE-ICE CONTROLLER ADJUSTMENT - continued

TABLE I. MAIN ROTOR BLADE ADJUSTMENT CHARTS (cont)

Blade Temp. (°C)	Main Rotor Adjustment Resistance (kiloohm)								
50.									
49.									
48.									
47.									
46.									
45.									
44.									
43.									
42.									
41.									
40.									
39.									
38.									
37.									
36.									
35.									
34.									
33.									
32.									
31.									
30.									0.02
29.							0.01	0.03	0.05
28.					0.00	0.02	0.05	0.07	0.09
27.				0.02	0.04	0.06	0.08	0.10	0.12
26.		0.01	0.03	0.05	0.07	0.09	0.11	0.13	0.15
25.	0.02	0.04	0.06	0.08	0.10	0.13	0.15	0.17	0.19
24.	0.05	0.08	0.10	0.12	0.14	0.16	0.18	0.20	0.22
23.	0.09	0.11	0.13	0.15	0.17	0.19	0.21	0.23	0.26
22.	0.12	0.14	0.16	0.18	0.21	0.23	0.25	0.27	0.29
21.	0.16	0.18	0.20	0.22	0.24	0.26	0.28	0.30	0.32
20.	0.19	0.21	0.23	0.25	0.27	0.29	0.32	0.34	0.36
19.	0.22	0.24	0.27	0.29	0.31	0.33	0.35	0.37	0.39
18.	0.26	0.28	0.30	0.32	0.34	0.36	0.38	0.41	0.43
17.	0.29	0.31	0.33	0.36	0.38	0.40	0.42	0.44	0.46
16.	0.33	0.35	0.37	0.39	0.41	0.43	0.45	0.47	0.50
15.	0.36	0.38	0.40	0.42	0.45	0.47	0.49	0.51	0.53
14.	0.39	0.42	0.44	0.46	0.48	0.50	0.52	0.54	0.56
13.	0.43	0.45	0.47	0.49	0.51	0.54	0.56	0.58	0.60
12.	0.46	0.49	0.51	0.53	0.55	0.57	0.59	0.61	0.63
11.	0.50	0.52	0.54	0.56	0.58	0.61	0.63	0.65	0.67
10.	0.53	0.56	0.58	0.60	0.62	0.64	0.66	0.68	0.71
9.	0.57	0.59	0.61	0.63	0.65	0.68	0.70	0.72	0.74
8.	0.60	0.63	0.65	0.67	0.69	0.71	0.73	0.75	0.78
7.	0.64	0.66	0.68	0.70	0.73	0.75	0.77	0.79	0.81
6.	0.67	0.70	0.72	0.74	0.76	0.78	0.80	0.83	0.85
5.	0.71	0.73	0.75	0.78	0.80	0.82	0.84	0.86	0.88
4.	0.75	0.77	0.79	0.81	0.83	0.85	0.88	0.90	0.92
3.	0.78	0.80	0.82	0.85	0.87	0.89	0.91	0.93	0.95
2.	0.82	0.84	0.86	0.88	0.90	0.93	0.95	0.97	0.99
1.	0.85	0.88	0.90	0.92	0.94	0.96	0.98	1.01	1.03
0.	0.89	0.91	0.93	0.95	0.98	1.00	1.02	1.04	1.06
-1.	0.93	0.95	0.97	0.99	1.01	1.03	1.06	1.08	1.10
-2.	0.96	0.98	1.01	1.03	1.05	1.07	1.09	1.11	1.14
-3.	1.00	1.02	1.04	1.06	1.09	1.11	1.13	1.15	1.17
-4.	1.03	1.06	1.08	1.10	1.12	1.14	1.17	1.19	1.21
-5.	1.07	1.09	1.11	1.14	1.16	1.18	1.20	1.22	1.25
-6.	1.11	1.13	1.15	1.17	1.20	1.22	1.24	1.26	1.28
-7.	1.14	1.17	1.19	1.21	1.23	1.25	1.28	1.30	1.32
-8.	1.18	1.20	1.23	1.25	1.27	1.29	1.31	1.34	1.36
-9.	1.22	1.24	1.26	1.28	1.31	1.33	1.35	1.37	1.39
-10.	1.26	1.28	1.30	1.32	1.34	1.37	1.39	1.41	1.43
-11.	1.29	1.32	1.34	1.36	1.38	1.40	1.43	1.45	1.47
-12.	1.33	1.35	1.37	1.40	1.42	1.44	1.46	1.49	1.51
-13.	1.37	1.39	1.41	1.43	1.46	1.48	1.50	1.52	1.55
-14.	1.41	1.43	1.45	1.47	1.49	1.52	1.54	1.56	1.58
-15.	1.44	1.47	1.49	1.51	1.53	1.55	1.58	1.60	1.62
-16.	1.48	1.50	1.53	1.55	1.57	1.59	1.61	1.64	1.66
-17.	1.52	1.54	1.56	1.59	1.61	1.63	1.65	1.68	1.70
-18.	1.56	1.58	1.60	1.62	1.65	1.67	1.69	1.71	1.74
-19.	1.60	1.62	1.64	1.66	1.69	1.71	1.73	1.75	1.77
-20.	1.63	1.66	1.68	1.70	1.72	1.75	1.77	1.79	1.81
	10.80	10.81	10.82	10.83	10.84	10.85	10.86	10.87	10.88
	Heater Resistance (Ohm) ----->								

GO TO NEXT PAGE

12.56. BLADE DE-ICE CONTROLLER ADJUSTMENT - continued

TABLE I. MAIN ROTOR BLADE ADJUSTMENT CHARTS (cont)

Blade Temp. (°C)	Main Rotor Adjustment Resistance (kiloohm)									
	10.89	10.90	10.91	10.92	10.93	10.94	10.95	10.96	10.97	
50.										
49.										
48.										
47.										
46.										
45.										
44.										
43.										
42.										
41.										
40.										
39.										
38.										
37.										
36.										0.01
35.								0.02		0.04
34.						0.01	0.03	0.05		0.07
33.				0.00	0.02	0.05	0.07	0.09		0.11
32.			0.02	0.04	0.06	0.08	0.10	0.12		0.14
31.	0.01	0.03	0.05	0.07	0.09	0.11	0.13	0.15		0.17
30.	0.04	0.06	0.08	0.10	0.12	0.15	0.17	0.19		0.21
29.	0.07	0.10	0.12	0.14	0.16	0.18	0.20	0.22		0.24
28.	0.11	0.13	0.15	0.17	0.19	0.21	0.23	0.25		0.27
27.	0.14	0.16	0.18	0.20	0.22	0.25	0.27	0.29		0.31
26.	0.18	0.20	0.22	0.24	0.26	0.28	0.30	0.32		0.34
25.	0.21	0.23	0.25	0.27	0.29	0.31	0.33	0.36		0.38
24.	0.24	0.26	0.28	0.31	0.33	0.35	0.37	0.39		0.41
23.	0.28	0.30	0.32	0.34	0.36	0.38	0.40	0.42		0.44
22.	0.31	0.33	0.35	0.37	0.39	0.42	0.44	0.46		0.48
21.	0.34	0.37	0.39	0.41	0.43	0.45	0.47	0.49		0.51
20.	0.38	0.40	0.42	0.44	0.46	0.48	0.51	0.53		0.55
19.	0.41	0.43	0.46	0.48	0.50	0.52	0.54	0.56		0.58
18.	0.45	0.47	0.49	0.51	0.53	0.55	0.57	0.60		0.62
17.	0.48	0.50	0.52	0.55	0.57	0.59	0.61	0.63		0.65
16.	0.52	0.54	0.56	0.58	0.60	0.62	0.64	0.66		0.69
15.	0.55	0.57	0.59	0.61	0.64	0.66	0.68	0.70		0.72
14.	0.59	0.61	0.63	0.65	0.67	0.69	0.71	0.73		0.76
13.	0.62	0.64	0.66	0.68	0.71	0.73	0.75	0.77		0.79
12.	0.66	0.68	0.70	0.72	0.74	0.76	0.78	0.81		0.83
11.	0.69	0.71	0.73	0.76	0.78	0.80	0.82	0.84		0.86
10.	0.73	0.75	0.77	0.79	0.81	0.83	0.85	0.88		0.90
9.	0.76	0.78	0.80	0.83	0.85	0.87	0.89	0.91		0.93
8.	0.80	0.82	0.84	0.86	0.88	0.90	0.93	0.95		0.97
7.	0.83	0.85	0.88	0.90	0.92	0.94	0.96	0.98		1.00
6.	0.87	0.89	0.91	0.93	0.95	0.98	1.00	1.02		1.04
5.	0.90	0.93	0.95	0.97	0.99	1.01	1.03	1.05		1.08
4.	0.94	0.96	0.98	1.00	1.03	1.05	1.07	1.09		1.11
3.	0.98	1.00	1.02	1.04	1.06	1.08	1.11	1.13		1.15
2.	1.01	1.03	1.06	1.08	1.10	1.12	1.14	1.16		1.19
1.	1.05	1.07	1.09	1.11	1.14	1.16	1.18	1.20		1.22
0.	1.08	1.11	1.13	1.15	1.17	1.19	1.21	1.24		1.26
-1.	1.12	1.14	1.16	1.19	1.21	1.23	1.25	1.27		1.29
-2.	1.16	1.18	1.20	1.22	1.24	1.27	1.29	1.31		1.33
-3.	1.19	1.22	1.24	1.26	1.28	1.30	1.33	1.35		1.37
-4.	1.23	1.25	1.27	1.30	1.32	1.34	1.36	1.38		1.41
-5.	1.27	1.29	1.31	1.33	1.36	1.38	1.40	1.42		1.44
-6.	1.31	1.33	1.35	1.37	1.39	1.41	1.44	1.46		1.48
-7.	1.34	1.36	1.39	1.41	1.43	1.45	1.47	1.50		1.52
-8.	1.38	1.40	1.42	1.45	1.47	1.49	1.51	1.53		1.56
-9.	1.42	1.44	1.46	1.48	1.50	1.53	1.55	1.57		1.59
-10.	1.45	1.48	1.50	1.52	1.54	1.56	1.59	1.61		1.63
-11.	1.49	1.51	1.54	1.56	1.58	1.60	1.62	1.65		1.67
-12.	1.53	1.55	1.57	1.60	1.62	1.64	1.66	1.68		1.71
-13.	1.57	1.59	1.61	1.63	1.66	1.68	1.70	1.72		1.74
-14.	1.61	1.63	1.65	1.67	1.69	1.72	1.74	1.76		1.78
-15.	1.64	1.67	1.69	1.71	1.73	1.75	1.78	1.80		1.82
-16.	1.68	1.70	1.73	1.75	1.77	1.79	1.81	1.84		1.86
-17.	1.72	1.74	1.76	1.79	1.81	1.83	1.85	1.88		1.90
-18.	1.76	1.78	1.80	1.83	1.85	1.87	1.89	1.91		1.94
-19.	1.80	1.82	1.84	1.86	1.89	1.91	1.93	1.95		1.98
-20.	1.84	1.86	1.88	1.90	1.93	1.95	1.97	1.99		2.01

Heater Resistance (Ohm) ----->

GO TO NEXT PAGE

12.56. BLADE DE-ICE CONTROLLER ADJUSTMENT - continued

TABLE I. MAIN ROTOR BLADE ADJUSTMENT CHARTS (cont)

Blade Temp. (°C)	Main Rotor Adjustment Resistance (Kiloohm)									
	10.98	10.99	11.00	11.01	11.02	11.03	11.04	11.05	11.06	
50.										
49.										
48.										
47.										
46.										
45.										
44.										
43.										
42.										
41.								0.01	0.03	
40.							0.02	0.04	0.06	
39.					0.01	0.03	0.05	0.07	0.09	
38.			0.00	0.02	0.05	0.07	0.09	0.11	0.13	
37.		0.02	0.04	0.06	0.08	0.10	0.12	0.14	0.16	
36.	0.03	0.05	0.07	0.09	0.11	0.13	0.15	0.17	0.19	
35.	0.06	0.08	0.10	0.12	0.14	0.16	0.19	0.21	0.23	
34.	0.09	0.12	0.14	0.16	0.18	0.20	0.22	0.24	0.26	
33.	0.13	0.15	0.17	0.19	0.21	0.23	0.25	0.27	0.29	
32.	0.16	0.18	0.20	0.22	0.24	0.26	0.29	0.31	0.33	
31.	0.19	0.22	0.24	0.26	0.28	0.30	0.32	0.34	0.36	
30.	0.23	0.25	0.27	0.29	0.31	0.33	0.35	0.37	0.39	
29.	0.26	0.28	0.30	0.32	0.34	0.37	0.39	0.41	0.43	
28.	0.30	0.32	0.34	0.36	0.38	0.40	0.42	0.44	0.46	
27.	0.33	0.35	0.37	0.39	0.41	0.43	0.45	0.47	0.50	
26.	0.36	0.38	0.40	0.43	0.45	0.47	0.49	0.51	0.53	
25.	0.40	0.42	0.44	0.46	0.48	0.50	0.52	0.54	0.56	
24.	0.43	0.45	0.47	0.49	0.51	0.54	0.56	0.58	0.60	
23.	0.47	0.49	0.51	0.53	0.55	0.57	0.59	0.61	0.63	
22.	0.50	0.52	0.54	0.56	0.58	0.60	0.63	0.65	0.67	
21.	0.53	0.55	0.58	0.60	0.62	0.64	0.66	0.68	0.70	
20.	0.57	0.59	0.61	0.63	0.65	0.67	0.69	0.72	0.74	
19.	0.60	0.62	0.64	0.67	0.69	0.71	0.73	0.75	0.77	
18.	0.64	0.66	0.68	0.70	0.72	0.74	0.76	0.79	0.81	
17.	0.67	0.69	0.71	0.74	0.76	0.78	0.80	0.82	0.84	
16.	0.71	0.73	0.75	0.77	0.79	0.81	0.83	0.86	0.88	
15.	0.74	0.76	0.78	0.81	0.83	0.85	0.87	0.89	0.91	
14.	0.78	0.80	0.82	0.84	0.86	0.88	0.90	0.93	0.95	
13.	0.81	0.83	0.85	0.88	0.90	0.92	0.94	0.96	0.98	
12.	0.85	0.87	0.89	0.91	0.93	0.95	0.98	1.00	1.02	
11.	0.88	0.90	0.93	0.95	0.97	0.99	1.01	1.03	1.05	
10.	0.92	0.94	0.96	0.98	1.00	1.03	1.05	1.07	1.09	
9.	0.95	0.98	1.00	1.02	1.04	1.06	1.08	1.10	1.13	
8.	0.99	1.01	1.03	1.05	1.08	1.10	1.12	1.14	1.16	
7.	1.03	1.05	1.07	1.09	1.11	1.13	1.15	1.18	1.20	
6.	1.06	1.08	1.10	1.13	1.15	1.17	1.19	1.21	1.23	
5.	1.10	1.12	1.14	1.16	1.18	1.21	1.23	1.25	1.27	
4.	1.13	1.16	1.18	1.20	1.22	1.24	1.26	1.29	1.31	
3.	1.17	1.19	1.21	1.24	1.26	1.28	1.30	1.32	1.34	
2.	1.21	1.23	1.25	1.27	1.29	1.31	1.34	1.36	1.38	
1.	1.24	1.26	1.29	1.31	1.33	1.35	1.37	1.39	1.42	
0.	1.28	1.30	1.32	1.35	1.37	1.39	1.41	1.43	1.45	
-1.	1.32	1.34	1.36	1.38	1.40	1.43	1.45	1.47	1.49	
-2.	1.35	1.38	1.40	1.42	1.44	1.46	1.48	1.51	1.53	
-3.	1.39	1.41	1.43	1.46	1.48	1.50	1.52	1.54	1.56	
-4.	1.43	1.45	1.47	1.49	1.51	1.54	1.56	1.58	1.60	
-5.	1.46	1.49	1.51	1.53	1.55	1.57	1.60	1.62	1.64	
-6.	1.50	1.52	1.55	1.57	1.59	1.61	1.63	1.66	1.68	
-7.	1.54	1.56	1.58	1.61	1.63	1.65	1.67	1.69	1.71	
-8.	1.58	1.60	1.62	1.64	1.66	1.69	1.71	1.73	1.75	
-9.	1.61	1.64	1.66	1.68	1.70	1.72	1.75	1.77	1.79	
-10.	1.65	1.67	1.70	1.72	1.74	1.76	1.78	1.81	1.83	
-11.	1.69	1.71	1.73	1.76	1.78	1.80	1.82	1.84	1.87	
-12.	1.73	1.75	1.77	1.79	1.82	1.84	1.86	1.88	1.91	
-13.	1.77	1.79	1.81	1.83	1.86	1.88	1.90	1.92	1.94	
-14.	1.80	1.83	1.85	1.87	1.89	1.92	1.94	1.96	1.98	
-15.	1.84	1.87	1.89	1.91	1.93	1.95	1.98	2.00	2.02	
-16.	1.88	1.90	1.93	1.95	1.97	1.99	2.02	2.04	2.06	
-17.	1.92	1.94	1.96	1.99	2.01	2.03	2.05	2.08	2.10	
-18.	1.96	1.98	2.00	2.03	2.05	2.07	2.09	2.12	2.14	
-19.	2.00	2.02	2.04	2.06	2.09	2.11	2.13	2.15	2.18	
-20.	2.04	2.06	2.08	2.10	2.13	2.15	2.17	2.19	2.22	
	10.98	10.99	11.00	11.01	11.02	11.03	11.04	11.05	11.06	

Heater Resistance (Ohm) ----->

GO TO NEXT PAGE

12.56. BLADE DE-ICE CONTROLLER ADJUSTMENT - continued

TABLE I. MAIN ROTOR BLADE ADJUSTMENT CHARTS (cont)

Blade Temp. (°C)	Main Rotor Adjustment Resistance (Kiloohm)									
	11.07	11.08	11.09	11.10	11.11	11.12	11.13	11.14	11.15	
50.										
49.										
48.										
47.										0.02
46.							0.01	0.03		0.05
45.						0.02	0.04	0.06		0.08
44.				0.01	0.03	0.05	0.07	0.09		0.11
43.		0.00	0.02	0.04	0.07	0.09	0.11	0.13		0.15
42.	0.02	0.04	0.06	0.08	0.10	0.12	0.14	0.16		0.18
41.	0.05	0.07	0.09	0.11	0.13	0.15	0.17	0.19		0.21
40.	0.08	0.10	0.12	0.14	0.16	0.18	0.20	0.22		0.25
39.	0.11	0.14	0.16	0.18	0.20	0.22	0.24	0.26		0.28
38.	0.15	0.17	0.19	0.21	0.23	0.25	0.27	0.29		0.31
37.	0.18	0.20	0.22	0.24	0.26	0.28	0.30	0.32		0.34
36.	0.21	0.23	0.25	0.28	0.30	0.32	0.34	0.36		0.38
35.	0.25	0.27	0.29	0.31	0.33	0.35	0.37	0.39		0.41
34.	0.28	0.30	0.32	0.34	0.36	0.38	0.40	0.42		0.45
33.	0.31	0.33	0.36	0.38	0.40	0.42	0.44	0.46		0.48
32.	0.35	0.37	0.39	0.41	0.43	0.45	0.47	0.49		0.51
31.	0.38	0.40	0.42	0.44	0.46	0.48	0.51	0.53		0.55
30.	0.41	0.44	0.46	0.48	0.50	0.52	0.54	0.56		0.58
29.	0.45	0.47	0.49	0.51	0.53	0.55	0.57	0.59		0.61
28.	0.48	0.50	0.52	0.54	0.57	0.59	0.61	0.63		0.65
27.	0.52	0.54	0.56	0.58	0.60	0.62	0.64	0.66		0.68
26.	0.55	0.57	0.59	0.61	0.63	0.65	0.68	0.70		0.72
25.	0.58	0.61	0.63	0.65	0.67	0.69	0.71	0.73		0.75
24.	0.62	0.64	0.66	0.68	0.70	0.72	0.74	0.77		0.79
23.	0.65	0.67	0.70	0.72	0.74	0.76	0.78	0.80		0.82
22.	0.69	0.71	0.73	0.75	0.77	0.79	0.81	0.84		0.86
21.	0.72	0.74	0.76	0.79	0.81	0.83	0.85	0.87		0.89
20.	0.76	0.78	0.80	0.82	0.84	0.86	0.88	0.90		0.93
19.	0.79	0.81	0.83	0.86	0.88	0.90	0.92	0.94		0.96
18.	0.83	0.85	0.87	0.89	0.91	0.93	0.95	0.98		1.00
17.	0.86	0.88	0.90	0.93	0.95	0.97	0.99	1.01		1.03
16.	0.90	0.92	0.94	0.96	0.98	1.00	1.02	1.05		1.07
15.	0.93	0.95	0.98	1.00	1.02	1.04	1.06	1.08		1.10
14.	0.97	0.99	1.01	1.03	1.05	1.07	1.10	1.12		1.14
13.	1.00	1.03	1.05	1.07	1.09	1.11	1.13	1.15		1.17
12.	1.04	1.06	1.08	1.10	1.12	1.15	1.17	1.19		1.21
11.	1.08	1.10	1.12	1.14	1.16	1.18	1.20	1.22		1.25
10.	1.11	1.13	1.15	1.18	1.20	1.22	1.24	1.26		1.28
9.	1.15	1.17	1.19	1.21	1.23	1.25	1.28	1.30		1.32
8.	1.18	1.20	1.23	1.25	1.27	1.29	1.31	1.33		1.35
7.	1.22	1.24	1.26	1.28	1.30	1.33	1.35	1.37		1.39
6.	1.26	1.28	1.30	1.32	1.34	1.36	1.38	1.41		1.43
5.	1.29	1.31	1.33	1.36	1.38	1.40	1.42	1.44		1.46
4.	1.33	1.35	1.37	1.39	1.41	1.44	1.46	1.48		1.50
3.	1.36	1.39	1.41	1.43	1.45	1.47	1.49	1.52		1.54
2.	1.40	1.42	1.44	1.47	1.49	1.51	1.53	1.55		1.57
1.	1.44	1.46	1.48	1.50	1.52	1.55	1.57	1.59		1.61
0.	1.48	1.50	1.52	1.54	1.56	1.58	1.61	1.63		1.65
-1.	1.51	1.53	1.56	1.58	1.60	1.62	1.64	1.66		1.69
-2.	1.55	1.57	1.59	1.61	1.64	1.66	1.68	1.70		1.72
-3.	1.59	1.61	1.63	1.65	1.67	1.70	1.72	1.74		1.76
-4.	1.62	1.65	1.67	1.69	1.71	1.73	1.76	1.78		1.80
-5.	1.66	1.68	1.71	1.73	1.75	1.77	1.79	1.81		1.84
-6.	1.70	1.72	1.74	1.76	1.79	1.81	1.83	1.85		1.87
-7.	1.74	1.76	1.78	1.80	1.82	1.85	1.87	1.89		1.91
-8.	1.77	1.80	1.82	1.84	1.86	1.88	1.91	1.93		1.95
-9.	1.81	1.83	1.86	1.88	1.90	1.92	1.94	1.97		1.99
-10.	1.85	1.87	1.89	1.92	1.94	1.96	1.98	2.01		2.03
-11.	1.89	1.91	1.93	1.96	1.98	2.00	2.02	2.04		2.07
-12.	1.93	1.95	1.97	1.99	2.02	2.04	2.06	2.08		2.10
-13.	1.97	1.99	2.01	2.03	2.05	2.08	2.10	2.12		2.14
-14.	2.00	2.03	2.05	2.07	2.09	2.12	2.14	2.16		2.18
-15.	2.04	2.07	2.09	2.11	2.13	2.15	2.18	2.20		2.22
-16.	2.08	2.10	2.13	2.15	2.17	2.19	2.22	2.24		2.26
-17.	2.12	2.14	2.17	2.19	2.21	2.23	2.25	2.28		2.30
-18.	2.16	2.18	2.20	2.23	2.25	2.27	2.29	2.32		2.34
-19.	2.20	2.22	2.24	2.27	2.29	2.31	2.33	2.36		2.38
-20.	2.24	2.26	2.28	2.31	2.33	2.35	2.37	2.40		2.42
	11.07	11.08	11.09	11.10	11.11	11.12	11.13	11.14	11.15	

Heater Resistance (Ohm) ----->

GO TO NEXT PAGE

12.56. BLADE DE-ICE CONTROLLER ADJUSTMENT - continued

TABLE I. MAIN ROTOR BLADE ADJUSTMENT CHARTS (cont)

Blade Temp. (°C)	Main Rotor Adjustment Resistance (Kiloohm)								
	0.00	0.02	0.04	0.06	0.08	0.10	0.12	0.14	0.16
50.			0.01	0.03	0.02	0.04	0.06	0.08	0.10
49.			0.01	0.03	0.05	0.07	0.09	0.11	0.13
48.	0.00	0.02	0.04	0.06	0.08	0.10	0.13	0.15	0.17
47.	0.04	0.06	0.08	0.10	0.12	0.14	0.16	0.18	0.20
46.	0.07	0.09	0.11	0.13	0.15	0.17	0.19	0.21	0.23
45.	0.10	0.12	0.14	0.16	0.18	0.20	0.22	0.24	0.26
44.	0.13	0.15	0.17	0.19	0.22	0.24	0.26	0.28	0.30
43.	0.17	0.19	0.21	0.23	0.25	0.27	0.29	0.31	0.33
42.	0.20	0.22	0.24	0.26	0.28	0.30	0.32	0.34	0.36
41.	0.23	0.25	0.27	0.29	0.31	0.33	0.35	0.38	0.40
40.	0.27	0.29	0.31	0.33	0.35	0.37	0.39	0.41	0.43
39.	0.30	0.32	0.34	0.36	0.38	0.40	0.42	0.44	0.46
38.	0.33	0.35	0.37	0.39	0.41	0.43	0.45	0.48	0.50
37.	0.37	0.39	0.41	0.43	0.45	0.47	0.49	0.51	0.53
36.	0.40	0.42	0.44	0.46	0.48	0.50	0.52	0.54	0.56
35.	0.43	0.45	0.47	0.49	0.51	0.54	0.56	0.58	0.60
34.	0.47	0.49	0.51	0.53	0.55	0.57	0.59	0.61	0.63
33.	0.50	0.52	0.54	0.56	0.58	0.60	0.62	0.64	0.66
32.	0.53	0.55	0.57	0.60	0.62	0.64	0.66	0.68	0.70
31.	0.57	0.59	0.61	0.63	0.65	0.67	0.69	0.71	0.73
30.	0.60	0.62	0.64	0.66	0.68	0.70	0.73	0.75	0.77
29.	0.64	0.66	0.68	0.70	0.72	0.74	0.76	0.78	0.80
28.	0.67	0.69	0.71	0.73	0.75	0.77	0.79	0.82	0.84
27.	0.70	0.72	0.75	0.77	0.79	0.81	0.83	0.85	0.87
26.	0.74	0.76	0.78	0.80	0.82	0.84	0.86	0.88	0.91
25.	0.77	0.79	0.81	0.84	0.86	0.88	0.90	0.92	0.94
24.	0.81	0.83	0.85	0.87	0.89	0.91	0.93	0.95	0.97
23.	0.84	0.86	0.88	0.91	0.93	0.95	0.97	0.99	1.01
22.	0.88	0.90	0.92	0.94	0.96	0.98	1.00	1.02	1.04
21.	0.91	0.93	0.95	0.98	1.00	1.02	1.04	1.06	1.08
20.	0.95	0.97	0.99	1.01	1.03	1.05	1.07	1.09	1.12
19.	0.98	1.00	1.02	1.05	1.07	1.09	1.11	1.13	1.15
18.	1.02	1.04	1.06	1.08	1.10	1.12	1.14	1.17	1.19
17.	1.05	1.07	1.10	1.12	1.14	1.16	1.18	1.20	1.22
16.	1.09	1.11	1.13	1.15	1.17	1.19	1.22	1.24	1.26
15.	1.12	1.14	1.17	1.19	1.21	1.23	1.25	1.27	1.29
14.	1.16	1.18	1.20	1.22	1.24	1.27	1.29	1.31	1.33
13.	1.20	1.22	1.24	1.26	1.28	1.30	1.32	1.34	1.37
12.	1.23	1.25	1.27	1.30	1.32	1.34	1.36	1.38	1.40
11.	1.27	1.29	1.31	1.33	1.35	1.37	1.40	1.42	1.44
10.	1.30	1.32	1.35	1.37	1.39	1.41	1.43	1.45	1.47
9.	1.34	1.36	1.38	1.40	1.43	1.45	1.47	1.49	1.51
8.	1.38	1.40	1.42	1.44	1.46	1.48	1.50	1.53	1.55
7.	1.41	1.43	1.46	1.48	1.50	1.52	1.54	1.56	1.58
6.	1.45	1.47	1.49	1.51	1.53	1.56	1.58	1.60	1.62
5.	1.49	1.51	1.53	1.55	1.57	1.59	1.61	1.64	1.66
4.	1.52	1.54	1.57	1.59	1.61	1.63	1.65	1.67	1.69
3.	1.56	1.58	1.60	1.62	1.65	1.67	1.69	1.71	1.73
2.	1.60	1.62	1.64	1.66	1.68	1.70	1.73	1.75	1.77
1.	1.63	1.65	1.68	1.70	1.72	1.74	1.76	1.78	1.81
0.	1.67	1.69	1.71	1.74	1.76	1.78	1.80	1.82	1.84
-1.	1.71	1.73	1.75	1.77	1.79	1.82	1.84	1.86	1.88
-2.	1.75	1.77	1.79	1.81	1.83	1.85	1.88	1.90	1.92
-3.	1.78	1.80	1.83	1.85	1.87	1.89	1.91	1.94	1.96
-4.	1.82	1.84	1.86	1.89	1.91	1.93	1.95	1.97	2.00
-5.	1.86	1.88	1.90	1.92	1.95	1.97	1.99	2.01	2.03
-6.	1.90	1.92	1.94	1.96	1.98	2.01	2.03	2.05	2.07
-7.	1.93	1.96	1.98	2.00	2.02	2.04	2.07	2.09	2.11
-8.	1.97	1.99	2.02	2.04	2.06	2.08	2.10	2.13	2.15
-9.	2.01	2.03	2.05	2.08	2.10	2.12	2.14	2.16	2.19
-10.	2.05	2.07	2.09	2.12	2.14	2.16	2.18	2.20	2.23
-11.	2.09	2.11	2.13	2.15	2.18	2.20	2.22	2.24	2.26
-12.	2.13	2.15	2.17	2.19	2.21	2.24	2.26	2.28	2.30
-13.	2.17	2.19	2.21	2.23	2.25	2.28	2.30	2.32	2.34
-14.	2.20	2.23	2.25	2.27	2.29	2.31	2.34	2.36	2.38
-15.	2.24	2.27	2.29	2.31	2.33	2.35	2.38	2.40	2.42
-16.	2.28	2.30	2.33	2.35	2.37	2.39	2.42	2.44	2.46
-17.	2.32	2.34	2.37	2.39	2.41	2.43	2.45	2.48	2.50
-18.	2.36	2.38	2.41	2.43	2.45	2.47	2.49	2.52	2.54
-19.	2.40	2.42	2.44	2.47	2.49	2.51	2.53	2.56	2.58
-20.	2.44	2.46	2.48	2.51	2.53	2.55	2.57	2.60	2.62
	11.16	11.17	11.18	11.19	11.20	11.21	11.22	11.23	11.24

Heater Resistance (Ohm) ----->

GO TO NEXT PAGE

12.56. BLADE DE-ICE CONTROLLER ADJUSTMENT - continued

TABLE I. MAIN ROTOR BLADE ADJUSTMENT CHARTS (cont)

Blade Temp. (°C)	Main Rotor Adjustment Resistance (Kiloohm)									
	0.12	0.14	0.16	0.18	0.20	0.22	0.24	0.26	0.28	
50.	0.12	0.14	0.16	0.18	0.20	0.22	0.24	0.26	0.28	
49.	0.15	0.17	0.19	0.21	0.23	0.25	0.27	0.29	0.31	
48.	0.19	0.21	0.23	0.25	0.27	0.29	0.31	0.33	0.35	
47.	0.22	0.24	0.26	0.28	0.30	0.32	0.34	0.36	0.38	
46.	0.25	0.27	0.29	0.31	0.33	0.35	0.37	0.39	0.41	
45.	0.28	0.30	0.32	0.34	0.37	0.39	0.41	0.43	0.45	
44.	0.32	0.34	0.36	0.38	0.40	0.42	0.44	0.46	0.48	
43.	0.35	0.37	0.39	0.41	0.43	0.45	0.47	0.49	0.51	
42.	0.38	0.40	0.42	0.44	0.46	0.48	0.51	0.53	0.55	
41.	0.42	0.44	0.46	0.48	0.50	0.52	0.54	0.56	0.58	
40.	0.45	0.47	0.49	0.51	0.53	0.55	0.57	0.59	0.61	
39.	0.48	0.50	0.52	0.54	0.56	0.59	0.61	0.63	0.65	
38.	0.52	0.54	0.56	0.58	0.60	0.62	0.64	0.66	0.68	
37.	0.55	0.57	0.59	0.61	0.63	0.65	0.67	0.69	0.71	
36.	0.58	0.60	0.62	0.65	0.67	0.69	0.71	0.73	0.75	
35.	0.62	0.64	0.66	0.68	0.70	0.72	0.74	0.76	0.78	
34.	0.65	0.67	0.69	0.71	0.73	0.75	0.78	0.80	0.82	
33.	0.69	0.71	0.73	0.75	0.77	0.79	0.81	0.83	0.85	
32.	0.72	0.74	0.76	0.78	0.80	0.82	0.84	0.86	0.88	
31.	0.75	0.77	0.80	0.82	0.84	0.86	0.88	0.90	0.92	
30.	0.79	0.81	0.83	0.85	0.87	0.89	0.91	0.93	0.95	
29.	0.82	0.84	0.86	0.88	0.91	0.93	0.95	0.97	0.99	
28.	0.86	0.88	0.90	0.92	0.94	0.96	0.98	1.00	1.02	
27.	0.89	0.91	0.93	0.95	0.97	1.00	1.02	1.04	1.06	
26.	0.93	0.95	0.97	0.99	1.01	1.03	1.05	1.07	1.09	
25.	0.96	0.98	1.00	1.02	1.04	1.07	1.09	1.11	1.13	
24.	1.00	1.02	1.04	1.06	1.08	1.10	1.12	1.14	1.16	
23.	1.03	1.05	1.07	1.09	1.11	1.14	1.16	1.18	1.20	
22.	1.07	1.09	1.11	1.13	1.15	1.17	1.19	1.21	1.23	
21.	1.10	1.12	1.14	1.16	1.19	1.21	1.23	1.25	1.27	
20.	1.14	1.16	1.18	1.20	1.22	1.24	1.26	1.28	1.30	
19.	1.17	1.19	1.21	1.24	1.26	1.28	1.30	1.32	1.34	
18.	1.21	1.23	1.25	1.27	1.29	1.31	1.33	1.36	1.38	
17.	1.24	1.26	1.29	1.31	1.33	1.35	1.37	1.39	1.41	
16.	1.28	1.30	1.32	1.34	1.36	1.38	1.41	1.43	1.45	
15.	1.31	1.34	1.36	1.38	1.40	1.42	1.44	1.46	1.48	
14.	1.35	1.37	1.39	1.41	1.44	1.46	1.48	1.50	1.52	
13.	1.39	1.41	1.43	1.45	1.47	1.49	1.51	1.54	1.56	
12.	1.42	1.44	1.47	1.49	1.51	1.53	1.55	1.57	1.59	
11.	1.46	1.48	1.50	1.52	1.54	1.57	1.59	1.61	1.63	
10.	1.50	1.52	1.54	1.56	1.58	1.60	1.62	1.65	1.67	
9.	1.53	1.55	1.57	1.60	1.62	1.64	1.66	1.68	1.70	
8.	1.57	1.59	1.61	1.63	1.65	1.68	1.70	1.72	1.74	
7.	1.61	1.63	1.65	1.67	1.69	1.71	1.73	1.76	1.78	
6.	1.64	1.66	1.69	1.71	1.73	1.75	1.77	1.79	1.81	
5.	1.68	1.70	1.72	1.74	1.77	1.79	1.81	1.83	1.85	
4.	1.72	1.74	1.76	1.78	1.80	1.82	1.85	1.87	1.89	
3.	1.75	1.78	1.80	1.82	1.84	1.86	1.88	1.90	1.93	
2.	1.79	1.81	1.83	1.86	1.88	1.90	1.92	1.94	1.96	
1.	1.83	1.85	1.87	1.89	1.91	1.94	1.96	1.98	2.00	
0.	1.87	1.89	1.91	1.93	1.95	1.97	2.00	2.02	2.04	
-1.	1.90	1.93	1.95	1.97	1.99	2.01	2.03	2.06	2.08	
-2.	1.94	1.96	1.98	2.01	2.03	2.05	2.07	2.09	2.12	
-3.	1.98	2.00	2.02	2.04	2.07	2.09	2.11	2.13	2.15	
-4.	2.02	2.04	2.06	2.08	2.10	2.13	2.15	2.17	2.19	
-5.	2.06	2.08	2.10	2.12	2.14	2.16	2.19	2.21	2.23	
-6.	2.09	2.12	2.14	2.16	2.18	2.20	2.22	2.25	2.27	
-7.	2.13	2.15	2.18	2.20	2.22	2.24	2.26	2.29	2.31	
-8.	2.17	2.19	2.21	2.24	2.26	2.28	2.30	2.32	2.35	
-9.	2.21	2.23	2.25	2.27	2.30	2.32	2.34	2.36	2.38	
-10.	2.25	2.27	2.29	2.31	2.34	2.36	2.38	2.40	2.42	
-11.	2.29	2.31	2.33	2.35	2.37	2.40	2.42	2.44	2.46	
-12.	2.33	2.35	2.37	2.39	2.41	2.44	2.46	2.48	2.50	
-13.	2.36	2.39	2.41	2.43	2.45	2.47	2.50	2.52	2.54	
-14.	2.40	2.43	2.45	2.47	2.49	2.51	2.54	2.56	2.58	
-15.	2.44	2.46	2.49	2.51	2.53	2.55	2.58	2.60	2.62	
-16.	2.48	2.50	2.53	2.55	2.57	2.59	2.62	2.64	2.66	
-17.	2.52	2.54	2.57	2.59	2.61	2.63	2.66	2.68	2.70	
-18.	2.56	2.58	2.61	2.63	2.65	2.67	2.70	2.72	2.74	
-19.	2.60	2.62	2.65	2.67	2.69	2.71	2.74	2.76	2.78	
-20.	2.64	2.66	2.69	2.71	2.73	2.75	2.78	2.80	2.82	
	11.25	11.26	11.27	11.28	11.29	11.30	11.31	11.32	11.33	
	Heater Resistance (Ohm) ----->									

GO TO NEXT PAGE



12.56. BLADE DE-ICE CONTROLLER ADJUSTMENT - continued

TABLE I. MAIN ROTOR BLADE ADJUSTMENT CHARTS (cont)

Blade Temp. (°C)	Main Rotor Adjustment Resistance (Kiloohm)									
	0.30	0.32	0.34	0.36	0.38	0.40	0.42	0.44	0.46	0.48
50.	0.30	0.32	0.34	0.36	0.38	0.40	0.42	0.44	0.46	0.48
49.	0.33	0.35	0.38	0.40	0.42	0.44	0.46	0.48	0.50	0.52
48.	0.37	0.39	0.41	0.43	0.45	0.47	0.49	0.51	0.53	0.55
47.	0.40	0.42	0.44	0.46	0.48	0.50	0.52	0.54	0.56	0.58
46.	0.43	0.45	0.47	0.49	0.51	0.53	0.55	0.57	0.59	0.61
45.	0.47	0.49	0.51	0.53	0.55	0.57	0.59	0.61	0.63	0.65
44.	0.50	0.52	0.54	0.56	0.58	0.60	0.62	0.64	0.66	0.68
43.	0.53	0.55	0.57	0.59	0.61	0.63	0.65	0.67	0.69	0.71
42.	0.57	0.59	0.61	0.63	0.65	0.67	0.69	0.71	0.73	0.75
41.	0.60	0.62	0.64	0.66	0.68	0.70	0.72	0.74	0.76	0.78
40.	0.63	0.65	0.67	0.69	0.71	0.73	0.75	0.77	0.79	0.81
39.	0.67	0.69	0.71	0.73	0.75	0.77	0.79	0.81	0.83	0.85
38.	0.70	0.72	0.74	0.76	0.78	0.80	0.82	0.84	0.86	0.88
37.	0.73	0.75	0.77	0.79	0.81	0.83	0.85	0.87	0.89	0.91
36.	0.77	0.79	0.81	0.83	0.85	0.87	0.89	0.91	0.93	0.95
35.	0.80	0.82	0.84	0.86	0.88	0.90	0.92	0.94	0.96	0.98
34.	0.84	0.86	0.88	0.90	0.92	0.94	0.96	0.98	1.00	1.02
33.	0.87	0.89	0.91	0.93	0.95	0.97	0.99	1.01	1.03	1.05
32.	0.91	0.93	0.95	0.97	0.99	1.01	1.03	1.05	1.07	1.09
31.	0.94	0.96	0.98	1.00	1.02	1.04	1.06	1.08	1.10	1.12
30.	0.97	1.00	1.02	1.04	1.06	1.08	1.10	1.12	1.14	1.16
29.	1.01	1.03	1.05	1.07	1.09	1.11	1.13	1.15	1.17	1.19
28.	1.04	1.06	1.09	1.11	1.13	1.15	1.17	1.19	1.21	1.23
27.	1.08	1.10	1.12	1.14	1.16	1.18	1.20	1.22	1.24	1.26
26.	1.11	1.13	1.16	1.18	1.20	1.22	1.24	1.26	1.28	1.30
25.	1.15	1.17	1.19	1.21	1.23	1.25	1.27	1.29	1.31	1.33
24.	1.18	1.20	1.23	1.25	1.27	1.29	1.31	1.33	1.35	1.37
23.	1.22	1.24	1.26	1.28	1.30	1.32	1.34	1.36	1.38	1.40
22.	1.25	1.28	1.30	1.32	1.34	1.36	1.38	1.40	1.42	1.44
21.	1.29	1.31	1.33	1.35	1.37	1.40	1.42	1.44	1.46	1.48
20.	1.33	1.35	1.37	1.39	1.41	1.43	1.45	1.47	1.49	1.51
19.	1.36	1.38	1.40	1.42	1.44	1.46	1.48	1.50	1.52	1.54
18.	1.40	1.42	1.44	1.46	1.48	1.50	1.52	1.54	1.56	1.58
17.	1.43	1.45	1.48	1.50	1.52	1.54	1.56	1.58	1.60	1.62
16.	1.47	1.49	1.51	1.53	1.55	1.58	1.60	1.62	1.64	1.66
15.	1.51	1.53	1.55	1.57	1.59	1.61	1.63	1.65	1.67	1.69
14.	1.54	1.56	1.58	1.61	1.63	1.65	1.67	1.69	1.71	1.73
13.	1.58	1.60	1.62	1.64	1.66	1.68	1.71	1.73	1.75	1.77
12.	1.61	1.64	1.66	1.68	1.70	1.72	1.74	1.76	1.78	1.80
11.	1.65	1.67	1.69	1.72	1.74	1.76	1.78	1.80	1.82	1.84
10.	1.69	1.71	1.73	1.75	1.77	1.79	1.82	1.84	1.86	1.88
9.	1.72	1.75	1.77	1.79	1.81	1.83	1.85	1.87	1.89	1.91
8.	1.76	1.78	1.80	1.83	1.85	1.87	1.89	1.91	1.93	1.95
7.	1.80	1.82	1.84	1.86	1.88	1.91	1.93	1.95	1.97	1.99
6.	1.84	1.86	1.88	1.90	1.92	1.94	1.96	1.99	2.01	2.03
5.	1.87	1.89	1.92	1.94	1.96	1.98	2.00	2.02	2.05	2.07
4.	1.91	1.93	1.95	1.97	2.00	2.02	2.04	2.06	2.08	2.10
3.	1.95	1.97	1.99	2.01	2.03	2.06	2.08	2.10	2.12	2.14
2.	1.99	2.01	2.03	2.05	2.07	2.09	2.12	2.14	2.16	2.18
1.	2.02	2.04	2.07	2.09	2.11	2.13	2.15	2.17	2.20	2.22
0.	2.06	2.08	2.10	2.13	2.15	2.17	2.19	2.21	2.23	2.25
-1.	2.10	2.12	2.14	2.16	2.19	2.21	2.23	2.25	2.27	2.29
-2.	2.14	2.16	2.18	2.20	2.22	2.25	2.27	2.29	2.31	2.33
-3.	2.18	2.20	2.22	2.24	2.26	2.28	2.31	2.33	2.35	2.37
-4.	2.21	2.24	2.26	2.28	2.30	2.32	2.34	2.37	2.39	2.41
-5.	2.25	2.27	2.30	2.32	2.34	2.36	2.38	2.40	2.43	2.45
-6.	2.29	2.31	2.33	2.36	2.38	2.40	2.42	2.44	2.47	2.49
-7.	2.33	2.35	2.37	2.39	2.42	2.44	2.46	2.48	2.50	2.52
-8.	2.37	2.39	2.41	2.43	2.46	2.48	2.50	2.52	2.54	2.56
-9.	2.41	2.43	2.45	2.47	2.49	2.52	2.54	2.56	2.58	2.60
-10.	2.45	2.47	2.49	2.51	2.53	2.56	2.58	2.60	2.62	2.64
-11.	2.48	2.51	2.53	2.55	2.57	2.60	2.62	2.64	2.66	2.68
-12.	2.52	2.55	2.57	2.59	2.61	2.63	2.66	2.68	2.70	2.72
-13.	2.56	2.59	2.61	2.63	2.65	2.67	2.70	2.72	2.74	2.76
-14.	2.60	2.63	2.65	2.67	2.69	2.71	2.74	2.76	2.78	2.80
-15.	2.64	2.66	2.69	2.71	2.73	2.75	2.78	2.80	2.82	2.84
-16.	2.68	2.70	2.73	2.75	2.77	2.79	2.82	2.84	2.86	2.88
-17.	2.72	2.74	2.77	2.79	2.81	2.83	2.86	2.88	2.90	2.92
-18.	2.76	2.78	2.81	2.83	2.85	2.87	2.90	2.92	2.94	2.96
-19.	2.80	2.82	2.85	2.87	2.89	2.91	2.94	2.96	2.98	3.00
-20.	2.84	2.87	2.89	2.91	2.93	2.95	2.98	3.00	3.02	3.04
	11.34	11.35	11.36	11.37	11.38	11.39	11.40	11.41	11.42	

Heater Resistance (Ohm) ----->

GO TO NEXT PAGE

12.56. BLADE DE-ICE CONTROLLER ADJUSTMENT - continued

TABLE I. MAIN ROTOR BLADE ADJUSTMENT CHARTS (cont)

Blade Temp. (°C)	Main Rotor Adjustment Resistance (Kiloohm)									
	0.48	0.50	0.52	0.54	0.56	0.58	0.60	0.62	0.64	0.66
50.	0.48	0.50	0.52	0.54	0.56	0.58	0.60	0.62	0.64	0.66
49.	0.52	0.54	0.56	0.58	0.60	0.62	0.64	0.66	0.68	0.70
48.	0.55	0.57	0.59	0.61	0.63	0.65	0.67	0.69	0.71	0.73
47.	0.58	0.60	0.62	0.64	0.66	0.68	0.70	0.72	0.74	0.76
46.	0.62	0.64	0.66	0.68	0.70	0.72	0.74	0.76	0.78	0.80
45.	0.65	0.67	0.69	0.71	0.73	0.75	0.77	0.79	0.81	0.83
44.	0.68	0.70	0.72	0.74	0.76	0.78	0.80	0.82	0.84	0.86
43.	0.72	0.74	0.76	0.78	0.80	0.82	0.84	0.86	0.88	0.90
42.	0.75	0.77	0.79	0.81	0.83	0.85	0.87	0.89	0.91	0.93
41.	0.78	0.80	0.82	0.84	0.87	0.89	0.91	0.93	0.95	0.97
40.	0.82	0.84	0.86	0.88	0.90	0.92	0.94	0.96	0.98	1.00
39.	0.85	0.87	0.89	0.91	0.93	0.95	0.97	0.99	1.01	1.03
38.	0.89	0.91	0.93	0.95	0.97	0.99	1.01	1.03	1.05	1.07
37.	0.92	0.94	0.96	0.98	1.00	1.02	1.04	1.06	1.08	1.10
36.	0.95	0.97	0.99	1.02	1.04	1.06	1.08	1.10	1.12	1.14
35.	0.99	1.01	1.03	1.05	1.07	1.09	1.11	1.13	1.15	1.17
34.	1.02	1.04	1.06	1.08	1.10	1.13	1.15	1.17	1.19	1.21
33.	1.06	1.08	1.10	1.12	1.14	1.16	1.18	1.20	1.22	1.24
32.	1.09	1.11	1.13	1.15	1.17	1.19	1.22	1.24	1.26	1.28
31.	1.13	1.15	1.17	1.19	1.21	1.23	1.25	1.27	1.29	1.31
30.	1.16	1.18	1.20	1.22	1.24	1.26	1.29	1.31	1.33	1.35
29.	1.20	1.22	1.24	1.26	1.28	1.30	1.32	1.34	1.36	1.38
28.	1.23	1.25	1.27	1.29	1.31	1.34	1.36	1.38	1.40	1.42
27.	1.27	1.29	1.31	1.33	1.35	1.37	1.39	1.41	1.43	1.45
26.	1.30	1.32	1.34	1.36	1.38	1.41	1.43	1.45	1.47	1.49
25.	1.34	1.36	1.38	1.40	1.42	1.44	1.46	1.48	1.50	1.52
24.	1.37	1.39	1.41	1.44	1.46	1.48	1.50	1.52	1.54	1.56
23.	1.41	1.43	1.45	1.47	1.49	1.51	1.53	1.55	1.58	1.60
22.	1.44	1.46	1.49	1.51	1.53	1.55	1.57	1.59	1.61	1.63
21.	1.48	1.50	1.52	1.54	1.56	1.58	1.61	1.63	1.65	1.67
20.	1.52	1.54	1.56	1.58	1.60	1.62	1.64	1.66	1.68	1.70
19.	1.55	1.57	1.59	1.61	1.64	1.66	1.68	1.70	1.72	1.74
18.	1.59	1.61	1.63	1.65	1.67	1.69	1.71	1.74	1.76	1.78
17.	1.62	1.64	1.67	1.69	1.71	1.73	1.75	1.77	1.79	1.81
16.	1.66	1.68	1.70	1.72	1.74	1.77	1.79	1.81	1.83	1.85
15.	1.70	1.72	1.74	1.76	1.78	1.80	1.82	1.84	1.87	1.89
14.	1.73	1.75	1.78	1.80	1.82	1.84	1.86	1.88	1.90	1.92
13.	1.77	1.79	1.81	1.83	1.85	1.88	1.90	1.92	1.94	1.96
12.	1.81	1.83	1.85	1.87	1.89	1.91	1.93	1.96	1.98	2.00
11.	1.84	1.86	1.89	1.91	1.93	1.95	1.97	1.99	2.01	2.03
10.	1.88	1.90	1.92	1.94	1.97	1.99	2.01	2.03	2.05	2.07
9.	1.92	1.94	1.96	1.98	2.00	2.02	2.05	2.07	2.09	2.11
8.	1.95	1.98	2.00	2.02	2.04	2.06	2.08	2.10	2.13	2.15
7.	1.99	2.01	2.03	2.06	2.08	2.10	2.12	2.14	2.16	2.18
6.	2.03	2.05	2.07	2.09	2.12	2.14	2.16	2.18	2.20	2.22
5.	2.07	2.09	2.11	2.13	2.15	2.17	2.20	2.22	2.24	2.26
4.	2.10	2.13	2.15	2.17	2.19	2.21	2.23	2.26	2.28	2.30
3.	2.14	2.16	2.19	2.21	2.23	2.25	2.27	2.29	2.31	2.33
2.	2.18	2.20	2.22	2.24	2.27	2.29	2.31	2.33	2.35	2.37
1.	2.22	2.24	2.26	2.28	2.30	2.33	2.35	2.37	2.39	2.41
0.	2.26	2.28	2.30	2.32	2.34	2.36	2.39	2.41	2.43	2.45
-1.	2.29	2.32	2.34	2.36	2.38	2.40	2.42	2.45	2.47	2.49
-2.	2.33	2.35	2.38	2.40	2.42	2.44	2.46	2.49	2.51	2.53
-3.	2.37	2.39	2.41	2.44	2.46	2.48	2.50	2.52	2.55	2.57
-4.	2.41	2.43	2.45	2.48	2.50	2.52	2.54	2.56	2.58	2.60
-5.	2.45	2.47	2.49	2.51	2.54	2.56	2.58	2.60	2.62	2.64
-6.	2.49	2.51	2.53	2.55	2.57	2.60	2.62	2.64	2.66	2.68
-7.	2.53	2.55	2.57	2.59	2.61	2.64	2.66	2.68	2.70	2.72
-8.	2.57	2.59	2.61	2.63	2.65	2.68	2.70	2.72	2.74	2.76
-9.	2.60	2.63	2.65	2.67	2.69	2.71	2.74	2.76	2.78	2.80
-10.	2.64	2.67	2.69	2.71	2.73	2.75	2.78	2.80	2.82	2.84
-11.	2.68	2.71	2.73	2.75	2.77	2.79	2.82	2.84	2.86	2.88
-12.	2.72	2.75	2.77	2.79	2.81	2.83	2.86	2.88	2.90	2.92
-13.	2.76	2.78	2.81	2.83	2.85	2.87	2.90	2.92	2.94	2.96
-14.	2.80	2.82	2.85	2.87	2.89	2.91	2.94	2.96	2.98	3.00
-15.	2.84	2.86	2.89	2.91	2.93	2.95	2.98	3.00	3.02	3.04
-16.	2.88	2.90	2.93	2.95	2.97	2.99	3.02	3.04	3.06	3.08
-17.	2.92	2.95	2.97	2.99	3.01	3.03	3.06	3.08	3.10	3.12
-18.	2.96	2.99	3.01	3.03	3.05	3.07	3.10	3.12	3.14	3.16
-19.	3.00	3.03	3.05	3.07	3.09	3.12	3.14	3.16	3.18	3.20
-20.	3.04	3.07	3.09	3.11	3.13	3.16	3.18	3.20	3.22	3.24
	11.43	11.44	11.45	11.46	11.47	11.48	11.49	11.50	11.51	11.52

Heater Resistance (Ohm) ----->

GO TO NEXT PAGE

12.56. BLADE DE-ICE CONTROLLER ADJUSTMENT - continued

TABLE I. MAIN ROTOR BLADE ADJUSTMENT CHARTS (cont)

Blade Temp. (°C)	Main Rotor Adjustment Resistance (Kiloohm)									
	0.66	0.68	0.70	0.73	0.75	0.77	0.79	0.81	0.83	
50.	0.66	0.68	0.70	0.73	0.75	0.77	0.79	0.81	0.83	
49.	0.70	0.72	0.74	0.76	0.78	0.80	0.82	0.84	0.86	
48.	0.73	0.75	0.77	0.79	0.81	0.83	0.85	0.87	0.89	
47.	0.76	0.78	0.81	0.83	0.85	0.87	0.89	0.91	0.93	
46.	0.80	0.82	0.84	0.86	0.88	0.90	0.92	0.94	0.96	
45.	0.83	0.85	0.87	0.89	0.91	0.93	0.95	0.97	0.99	
44.	0.87	0.89	0.91	0.93	0.95	0.97	0.99	1.01	1.03	
43.	0.90	0.92	0.94	0.96	0.98	1.00	1.02	1.04	1.06	
42.	0.93	0.95	0.97	0.99	1.01	1.04	1.06	1.08	1.10	
41.	0.97	0.99	1.01	1.03	1.05	1.07	1.09	1.11	1.13	
40.	1.00	1.02	1.04	1.06	1.08	1.10	1.12	1.14	1.16	
39.	1.04	1.06	1.08	1.10	1.12	1.14	1.16	1.18	1.20	
38.	1.07	1.09	1.11	1.13	1.15	1.17	1.19	1.21	1.23	
37.	1.10	1.12	1.15	1.17	1.19	1.21	1.23	1.25	1.27	
36.	1.14	1.16	1.18	1.20	1.22	1.24	1.26	1.28	1.30	
35.	1.17	1.19	1.21	1.23	1.26	1.28	1.30	1.32	1.34	
34.	1.21	1.23	1.25	1.27	1.29	1.31	1.33	1.35	1.37	
33.	1.24	1.26	1.28	1.30	1.33	1.35	1.37	1.39	1.41	
32.	1.28	1.30	1.32	1.34	1.36	1.38	1.40	1.42	1.44	
31.	1.31	1.33	1.35	1.37	1.40	1.42	1.44	1.46	1.48	
30.	1.35	1.37	1.39	1.41	1.43	1.45	1.47	1.49	1.51	
29.	1.38	1.40	1.42	1.45	1.47	1.49	1.51	1.53	1.55	
28.	1.42	1.44	1.46	1.48	1.50	1.52	1.54	1.56	1.58	
27.	1.45	1.47	1.50	1.52	1.54	1.56	1.58	1.60	1.62	
26.	1.49	1.51	1.53	1.55	1.57	1.59	1.61	1.64	1.66	
25.	1.52	1.55	1.57	1.59	1.61	1.63	1.65	1.67	1.69	
24.	1.56	1.58	1.60	1.62	1.64	1.67	1.69	1.71	1.73	
23.	1.60	1.62	1.64	1.66	1.68	1.70	1.72	1.74	1.76	
22.	1.63	1.65	1.67	1.70	1.72	1.74	1.76	1.78	1.80	
21.	1.67	1.69	1.71	1.73	1.75	1.77	1.79	1.82	1.84	
20.	1.70	1.73	1.75	1.77	1.79	1.81	1.83	1.85	1.87	
19.	1.74	1.76	1.78	1.80	1.83	1.85	1.87	1.89	1.91	
18.	1.78	1.80	1.82	1.84	1.86	1.88	1.90	1.93	1.95	
17.	1.81	1.83	1.86	1.88	1.90	1.92	1.94	1.96	1.98	
16.	1.85	1.87	1.89	1.91	1.94	1.96	1.98	2.00	2.02	
15.	1.89	1.91	1.93	1.95	1.97	1.99	2.01	2.04	2.06	
14.	1.92	1.95	1.97	1.99	2.01	2.03	2.05	2.07	2.09	
13.	1.96	1.98	2.00	2.02	2.05	2.07	2.09	2.11	2.13	
12.	2.00	2.02	2.04	2.06	2.08	2.10	2.13	2.15	2.17	
11.	2.04	2.06	2.08	2.10	2.12	2.14	2.16	2.18	2.21	
10.	2.07	2.09	2.12	2.14	2.16	2.18	2.20	2.22	2.24	
9.	2.11	2.13	2.15	2.17	2.20	2.22	2.24	2.26	2.28	
8.	2.15	2.17	2.19	2.21	2.23	2.25	2.28	2.30	2.32	
7.	2.18	2.21	2.23	2.25	2.27	2.29	2.31	2.34	2.36	
6.	2.22	2.24	2.27	2.29	2.31	2.33	2.35	2.37	2.39	
5.	2.26	2.28	2.30	2.32	2.35	2.37	2.39	2.41	2.43	
4.	2.30	2.32	2.34	2.36	2.38	2.41	2.43	2.45	2.47	
3.	2.34	2.36	2.38	2.40	2.42	2.44	2.47	2.49	2.51	
2.	2.37	2.40	2.42	2.44	2.46	2.48	2.50	2.53	2.55	
1.	2.41	2.43	2.46	2.48	2.50	2.52	2.54	2.56	2.59	
0.	2.45	2.47	2.49	2.52	2.54	2.56	2.58	2.60	2.62	
-1.	2.49	2.51	2.53	2.56	2.58	2.60	2.62	2.64	2.66	
-2.	2.53	2.55	2.57	2.59	2.62	2.64	2.66	2.68	2.70	
-3.	2.57	2.59	2.61	2.63	2.65	2.68	2.70	2.72	2.74	
-4.	2.61	2.63	2.65	2.67	2.69	2.72	2.74	2.76	2.78	
-5.	2.65	2.67	2.69	2.71	2.73	2.75	2.78	2.80	2.82	
-6.	2.68	2.71	2.73	2.75	2.77	2.79	2.82	2.84	2.86	
-7.	2.72	2.75	2.77	2.79	2.81	2.83	2.86	2.88	2.90	
-8.	2.76	2.79	2.81	2.83	2.85	2.87	2.89	2.92	2.94	
-9.	2.80	2.82	2.85	2.87	2.89	2.91	2.93	2.96	2.98	
-10.	2.84	2.86	2.89	2.91	2.93	2.95	2.97	3.00	3.02	
-11.	2.88	2.90	2.93	2.95	2.97	2.99	3.01	3.04	3.06	
-12.	2.92	2.94	2.97	2.99	3.01	3.03	3.05	3.08	3.10	
-13.	2.96	2.98	3.01	3.03	3.05	3.07	3.09	3.12	3.14	
-14.	3.00	3.02	3.05	3.07	3.09	3.11	3.14	3.16	3.18	
-15.	3.04	3.06	3.09	3.11	3.13	3.15	3.18	3.20	3.22	
-16.	3.08	3.10	3.13	3.15	3.17	3.19	3.22	3.24	3.26	
-17.	3.12	3.15	3.17	3.19	3.21	3.23	3.26	3.28	3.30	
-18.	3.16	3.19	3.21	3.23	3.25	3.28	3.30	3.32	3.34	
-19.	3.20	3.23	3.25	3.27	3.29	3.32	3.34	3.36	3.38	
-20.	3.25	3.27	3.29	3.31	3.34	3.36	3.38	3.40	3.42	
	11.52	11.53	11.54	11.55	11.56	11.57	11.58	11.59	11.60	
	Heater Resistance (Ohm) ----->									

GO TO NEXT PAGE

12.56. BLADE DE-ICE CONTROLLER ADJUSTMENT - continued

TABLE I. MAIN ROTOR BLADE ADJUSTMENT CHARTS (cont)

Blade Temp. (°C)	Main Rotor Adjustment Resistance (Kiloohm)									
	0.85	0.87	0.89	0.91	0.93	0.95	0.97	0.99	1.01	1.03
50.	0.85	0.87	0.89	0.91	0.93	0.95	0.97	0.99	1.01	1.03
49.	0.88	0.90	0.92	0.94	0.96	0.98	1.00	1.02	1.04	1.06
48.	0.91	0.93	0.95	0.97	0.99	1.01	1.03	1.05	1.07	1.09
47.	0.95	0.97	0.99	1.01	1.03	1.05	1.07	1.09	1.11	1.13
46.	0.98	1.00	1.02	1.04	1.06	1.08	1.10	1.12	1.14	1.16
45.	1.01	1.03	1.05	1.08	1.10	1.12	1.14	1.16	1.18	1.20
44.	1.05	1.07	1.09	1.11	1.13	1.15	1.17	1.19	1.21	1.23
43.	1.08	1.10	1.12	1.14	1.16	1.18	1.20	1.22	1.24	1.26
42.	1.12	1.14	1.16	1.18	1.20	1.22	1.24	1.26	1.28	1.30
41.	1.15	1.17	1.19	1.21	1.23	1.25	1.27	1.29	1.31	1.33
40.	1.19	1.21	1.23	1.25	1.27	1.29	1.31	1.33	1.35	1.37
39.	1.22	1.24	1.26	1.28	1.30	1.32	1.34	1.36	1.38	1.40
38.	1.25	1.27	1.30	1.32	1.34	1.36	1.38	1.40	1.42	1.44
37.	1.29	1.31	1.33	1.35	1.37	1.39	1.41	1.43	1.45	1.47
36.	1.32	1.34	1.36	1.39	1.41	1.43	1.45	1.47	1.49	1.51
35.	1.36	1.38	1.40	1.42	1.44	1.46	1.48	1.50	1.52	1.54
34.	1.39	1.41	1.43	1.46	1.48	1.50	1.52	1.54	1.56	1.58
33.	1.43	1.45	1.47	1.49	1.51	1.53	1.55	1.57	1.59	1.61
32.	1.46	1.48	1.51	1.53	1.55	1.57	1.59	1.61	1.63	1.65
31.	1.50	1.52	1.54	1.56	1.58	1.60	1.62	1.64	1.66	1.68
30.	1.53	1.56	1.58	1.60	1.62	1.64	1.66	1.68	1.70	1.72
29.	1.57	1.59	1.61	1.63	1.65	1.67	1.69	1.72	1.74	1.76
28.	1.61	1.63	1.65	1.67	1.69	1.71	1.73	1.75	1.77	1.79
27.	1.64	1.66	1.68	1.70	1.72	1.75	1.77	1.79	1.81	1.83
26.	1.68	1.70	1.72	1.74	1.76	1.78	1.80	1.82	1.84	1.86
25.	1.71	1.73	1.75	1.78	1.80	1.82	1.84	1.86	1.88	1.90
24.	1.75	1.77	1.79	1.81	1.83	1.85	1.87	1.90	1.92	1.94
23.	1.79	1.81	1.83	1.85	1.87	1.89	1.91	1.93	1.95	1.97
22.	1.82	1.84	1.86	1.88	1.91	1.93	1.95	1.97	1.99	2.01
21.	1.86	1.88	1.90	1.92	1.94	1.96	1.98	2.00	2.03	2.05
20.	1.89	1.92	1.94	1.96	1.98	2.00	2.02	2.04	2.06	2.08
19.	1.93	1.95	1.97	1.99	2.01	2.04	2.06	2.08	2.10	2.12
18.	1.97	1.99	2.01	2.03	2.05	2.07	2.09	2.12	2.14	2.16
17.	2.00	2.03	2.05	2.07	2.09	2.11	2.13	2.15	2.17	2.19
16.	2.04	2.06	2.08	2.10	2.13	2.15	2.17	2.19	2.21	2.23
15.	2.08	2.10	2.12	2.14	2.16	2.18	2.21	2.23	2.25	2.27
14.	2.12	2.14	2.16	2.18	2.20	2.22	2.24	2.26	2.28	2.30
13.	2.15	2.17	2.19	2.22	2.24	2.26	2.28	2.30	2.32	2.34
12.	2.19	2.21	2.23	2.25	2.27	2.30	2.32	2.34	2.36	2.38
11.	2.23	2.25	2.27	2.29	2.31	2.33	2.36	2.38	2.40	2.42
10.	2.26	2.29	2.31	2.33	2.35	2.37	2.39	2.41	2.44	2.46
9.	2.30	2.32	2.35	2.37	2.39	2.41	2.43	2.45	2.47	2.49
8.	2.34	2.36	2.38	2.40	2.43	2.45	2.47	2.49	2.51	2.53
7.	2.38	2.40	2.42	2.44	2.46	2.49	2.51	2.53	2.55	2.57
6.	2.42	2.44	2.46	2.48	2.50	2.52	2.54	2.57	2.59	2.61
5.	2.45	2.48	2.50	2.52	2.54	2.56	2.58	2.60	2.63	2.65
4.	2.49	2.51	2.54	2.56	2.58	2.60	2.62	2.64	2.66	2.68
3.	2.53	2.55	2.57	2.60	2.62	2.64	2.66	2.68	2.70	2.72
2.	2.57	2.59	2.61	2.63	2.66	2.68	2.70	2.72	2.74	2.76
1.	2.61	2.63	2.65	2.67	2.69	2.72	2.74	2.76	2.78	2.80
0.	2.65	2.67	2.69	2.71	2.73	2.76	2.78	2.80	2.82	2.84
-1.	2.69	2.71	2.73	2.75	2.77	2.79	2.82	2.84	2.86	2.88
-2.	2.72	2.75	2.77	2.79	2.81	2.83	2.85	2.88	2.90	2.92
-3.	2.76	2.79	2.81	2.83	2.85	2.87	2.89	2.92	2.94	2.96
-4.	2.80	2.82	2.85	2.87	2.89	2.91	2.93	2.96	2.98	3.00
-5.	2.84	2.86	2.89	2.91	2.93	2.95	2.97	3.00	3.02	3.04
-6.	2.88	2.90	2.93	2.95	2.97	2.99	3.01	3.03	3.06	3.08
-7.	2.92	2.94	2.96	2.99	3.01	3.03	3.05	3.07	3.10	3.12
-8.	2.96	2.98	3.00	3.03	3.05	3.07	3.09	3.11	3.14	3.16
-9.	3.00	3.02	3.04	3.07	3.09	3.11	3.13	3.15	3.18	3.20
-10.	3.04	3.06	3.08	3.11	3.13	3.15	3.17	3.19	3.22	3.24
-11.	3.08	3.10	3.12	3.15	3.17	3.19	3.21	3.24	3.26	3.28
-12.	3.12	3.14	3.17	3.19	3.21	3.23	3.25	3.28	3.30	3.32
-13.	3.16	3.18	3.21	3.23	3.25	3.27	3.29	3.32	3.34	3.36
-14.	3.20	3.22	3.25	3.27	3.29	3.31	3.33	3.36	3.38	3.40
-15.	3.24	3.26	3.29	3.31	3.33	3.35	3.38	3.40	3.42	3.44
-16.	3.28	3.31	3.33	3.35	3.37	3.39	3.42	3.44	3.46	3.48
-17.	3.32	3.35	3.37	3.39	3.41	3.44	3.46	3.48	3.50	3.52
-18.	3.36	3.39	3.41	3.43	3.45	3.48	3.50	3.52	3.54	3.56
-19.	3.41	3.43	3.45	3.47	3.50	3.52	3.54	3.56	3.58	3.60
-20.	3.45	3.47	3.49	3.51	3.54	3.56	3.58	3.60	3.63	3.65
	11.61	11.62	11.63	11.64	11.65	11.66	11.67	11.68	11.69	
	Heater Resistance (Ohm) ----->									

GO TO NEXT PAGE

12.56. BLADE DE-ICE CONTROLLER ADJUSTMENT - continued

TABLE I. MAIN ROTOR BLADE ADJUSTMENT CHARTS (cont)

Blade Temp. (°C)	Main Rotor Adjustment Resistance (Kiloohm)								
	1.03	1.05	1.07	1.09	1.11	1.13	1.15	1.17	1.19
50.	1.03	1.05	1.07	1.09	1.11	1.13	1.15	1.17	1.19
49.	1.06	1.08	1.10	1.12	1.14	1.16	1.18	1.20	1.22
48.	1.09	1.11	1.14	1.16	1.18	1.20	1.22	1.24	1.26
47.	1.13	1.15	1.17	1.19	1.21	1.23	1.25	1.27	1.29
46.	1.16	1.18	1.20	1.22	1.24	1.26	1.28	1.30	1.32
45.	1.20	1.22	1.24	1.26	1.28	1.30	1.32	1.34	1.36
44.	1.23	1.25	1.27	1.29	1.31	1.33	1.35	1.37	1.39
43.	1.27	1.29	1.31	1.33	1.35	1.37	1.39	1.41	1.43
42.	1.30	1.32	1.34	1.36	1.38	1.40	1.42	1.44	1.46
41.	1.33	1.35	1.38	1.40	1.42	1.44	1.46	1.48	1.50
40.	1.37	1.39	1.41	1.43	1.45	1.47	1.49	1.51	1.53
39.	1.40	1.42	1.44	1.47	1.49	1.51	1.53	1.55	1.57
38.	1.44	1.46	1.48	1.50	1.52	1.54	1.56	1.58	1.60
37.	1.47	1.49	1.51	1.54	1.56	1.58	1.60	1.62	1.64
36.	1.51	1.53	1.55	1.57	1.59	1.61	1.63	1.65	1.67
35.	1.54	1.56	1.58	1.61	1.63	1.65	1.67	1.69	1.71
34.	1.58	1.60	1.62	1.64	1.66	1.68	1.70	1.72	1.74
33.	1.61	1.63	1.66	1.68	1.70	1.72	1.74	1.76	1.78
32.	1.65	1.67	1.69	1.71	1.73	1.75	1.77	1.79	1.82
31.	1.69	1.71	1.73	1.75	1.77	1.79	1.81	1.83	1.85
30.	1.72	1.74	1.76	1.78	1.80	1.82	1.85	1.87	1.89
29.	1.76	1.78	1.80	1.82	1.84	1.86	1.88	1.90	1.92
28.	1.79	1.81	1.83	1.86	1.88	1.90	1.92	1.94	1.96
27.	1.83	1.85	1.87	1.89	1.91	1.93	1.95	1.97	2.00
26.	1.86	1.89	1.91	1.93	1.95	1.97	1.99	2.01	2.03
25.	1.90	1.92	1.94	1.96	1.98	2.01	2.03	2.05	2.07
24.	1.94	1.96	1.98	2.00	2.02	2.04	2.06	2.08	2.10
23.	1.97	1.99	2.02	2.04	2.06	2.08	2.10	2.12	2.14
22.	2.01	2.03	2.05	2.07	2.09	2.12	2.14	2.16	2.18
21.	2.05	2.07	2.09	2.11	2.13	2.15	2.17	2.19	2.21
20.	2.08	2.10	2.13	2.15	2.17	2.19	2.21	2.23	2.25
19.	2.12	2.14	2.16	2.18	2.20	2.23	2.25	2.27	2.29
18.	2.16	2.18	2.20	2.22	2.24	2.26	2.28	2.31	2.33
17.	2.19	2.22	2.24	2.26	2.28	2.30	2.32	2.34	2.36
16.	2.23	2.25	2.27	2.29	2.32	2.34	2.36	2.38	2.40
15.	2.27	2.29	2.31	2.33	2.35	2.37	2.40	2.42	2.44
14.	2.31	2.33	2.35	2.37	2.39	2.41	2.43	2.45	2.48
13.	2.34	2.36	2.39	2.41	2.43	2.45	2.47	2.49	2.51
12.	2.38	2.40	2.42	2.45	2.47	2.49	2.51	2.53	2.55
11.	2.42	2.44	2.46	2.48	2.50	2.53	2.55	2.57	2.59
10.	2.46	2.48	2.50	2.52	2.54	2.56	2.59	2.61	2.63
9.	2.49	2.52	2.54	2.56	2.58	2.60	2.62	2.64	2.67
8.	2.53	2.55	2.58	2.60	2.62	2.64	2.66	2.68	2.70
7.	2.57	2.59	2.61	2.64	2.66	2.68	2.70	2.72	2.74
6.	2.61	2.63	2.65	2.67	2.70	2.72	2.74	2.76	2.78
5.	2.65	2.67	2.69	2.71	2.73	2.76	2.78	2.80	2.82
4.	2.69	2.71	2.73	2.75	2.77	2.79	2.82	2.84	2.86
3.	2.73	2.75	2.77	2.79	2.81	2.83	2.85	2.88	2.90
2.	2.76	2.79	2.81	2.83	2.85	2.87	2.89	2.92	2.94
1.	2.80	2.82	2.85	2.87	2.89	2.91	2.93	2.95	2.98
0.	2.84	2.86	2.89	2.91	2.93	2.95	2.97	2.99	3.02
-1.	2.88	2.90	2.92	2.95	2.97	2.99	3.01	3.03	3.05
-2.	2.92	2.94	2.96	2.99	3.01	3.03	3.05	3.07	3.09
-3.	2.96	2.98	3.00	3.03	3.05	3.07	3.09	3.11	3.13
-4.	3.00	3.02	3.04	3.06	3.09	3.11	3.13	3.15	3.17
-5.	3.04	3.06	3.08	3.10	3.13	3.15	3.17	3.19	3.21
-6.	3.08	3.10	3.12	3.14	3.17	3.19	3.21	3.23	3.25
-7.	3.12	3.14	3.16	3.18	3.21	3.23	3.25	3.27	3.29
-8.	3.16	3.18	3.20	3.22	3.25	3.27	3.29	3.31	3.33
-9.	3.20	3.22	3.24	3.26	3.29	3.31	3.33	3.35	3.37
-10.	3.24	3.26	3.28	3.30	3.33	3.35	3.37	3.39	3.42
-11.	3.28	3.30	3.32	3.35	3.37	3.39	3.41	3.43	3.46
-12.	3.32	3.34	3.36	3.39	3.41	3.43	3.45	3.47	3.50
-13.	3.36	3.38	3.40	3.43	3.45	3.47	3.49	3.52	3.54
-14.	3.40	3.42	3.45	3.47	3.49	3.51	3.53	3.56	3.58
-15.	3.44	3.46	3.49	3.51	3.53	3.55	3.58	3.60	3.62
-16.	3.48	3.51	3.53	3.55	3.57	3.59	3.62	3.64	3.66
-17.	3.52	3.55	3.57	3.59	3.61	3.64	3.66	3.68	3.70
-18.	3.57	3.59	3.61	3.63	3.65	3.68	3.70	3.72	3.74
-19.	3.61	3.63	3.65	3.67	3.70	3.72	3.74	3.76	3.79
-20.	3.65	3.67	3.69	3.72	3.74	3.76	3.78	3.81	3.83
	11.70	11.71	11.72	11.73	11.74	11.75	11.76	11.77	11.78
	Heater Resistance (Ohm) ----->								

GO TO NEXT PAGE

12.56. BLADE DE-ICE CONTROLLER ADJUSTMENT - continued

TABLE I. MAIN ROTOR BLADE ADJUSTMENT CHARTS (cont)

Blade Temp. (°C)	Main Rotor Adjustment Resistance (Kiloohm)								
50.	1.21	1.23	1.25	1.27	1.29	1.31	1.33	1.35	1.37
49.	1.24	1.26	1.28	1.30	1.32	1.34	1.36	1.38	1.40
48.	1.28	1.30	1.32	1.34	1.36	1.38	1.40	1.42	1.44
47.	1.31	1.33	1.35	1.37	1.39	1.41	1.43	1.45	1.47
46.	1.35	1.37	1.39	1.41	1.43	1.45	1.47	1.49	1.51
45.	1.38	1.40	1.42	1.44	1.46	1.48	1.50	1.52	1.54
44.	1.41	1.43	1.45	1.47	1.50	1.52	1.54	1.56	1.58
43.	1.45	1.47	1.49	1.51	1.53	1.55	1.57	1.59	1.61
42.	1.48	1.50	1.52	1.54	1.56	1.59	1.61	1.63	1.65
41.	1.52	1.54	1.56	1.58	1.60	1.62	1.64	1.66	1.68
40.	1.55	1.57	1.59	1.61	1.63	1.66	1.68	1.70	1.72
39.	1.59	1.61	1.63	1.65	1.67	1.69	1.71	1.73	1.75
38.	1.62	1.64	1.66	1.68	1.71	1.73	1.75	1.77	1.79
37.	1.66	1.68	1.70	1.72	1.74	1.76	1.78	1.80	1.82
36.	1.69	1.71	1.73	1.76	1.78	1.80	1.82	1.84	1.86
35.	1.73	1.75	1.77	1.79	1.81	1.83	1.85	1.87	1.89
34.	1.76	1.79	1.81	1.83	1.85	1.87	1.89	1.91	1.93
33.	1.80	1.82	1.84	1.86	1.88	1.90	1.92	1.94	1.97
32.	1.84	1.86	1.88	1.90	1.92	1.94	1.96	1.98	2.00
31.	1.87	1.89	1.91	1.93	1.95	1.98	2.00	2.02	2.04
30.	1.91	1.93	1.95	1.97	1.99	2.01	2.03	2.05	2.07
29.	1.94	1.96	1.99	2.01	2.03	2.05	2.07	2.09	2.11
28.	1.98	2.00	2.02	2.04	2.06	2.08	2.10	2.13	2.15
27.	2.02	2.04	2.06	2.08	2.10	2.12	2.14	2.16	2.18
26.	2.05	2.07	2.09	2.11	2.14	2.16	2.18	2.20	2.22
25.	2.09	2.11	2.13	2.15	2.17	2.19	2.21	2.24	2.26
24.	2.13	2.15	2.17	2.19	2.21	2.23	2.25	2.27	2.29
23.	2.16	2.18	2.20	2.22	2.25	2.27	2.29	2.31	2.33
22.	2.20	2.22	2.24	2.26	2.28	2.30	2.32	2.35	2.37
21.	2.24	2.26	2.28	2.30	2.32	2.34	2.36	2.38	2.40
20.	2.27	2.29	2.31	2.34	2.36	2.38	2.40	2.42	2.44
19.	2.31	2.33	2.35	2.37	2.39	2.42	2.44	2.46	2.48
18.	2.35	2.37	2.39	2.41	2.43	2.45	2.47	2.49	2.52
17.	2.38	2.41	2.43	2.45	2.47	2.49	2.51	2.53	2.55
16.	2.42	2.44	2.46	2.49	2.51	2.53	2.55	2.57	2.59
15.	2.46	2.48	2.50	2.52	2.54	2.57	2.59	2.61	2.63
14.	2.50	2.52	2.54	2.56	2.58	2.60	2.62	2.65	2.67
13.	2.54	2.56	2.58	2.60	2.62	2.64	2.66	2.68	2.71
12.	2.57	2.59	2.62	2.64	2.66	2.68	2.70	2.72	2.74
11.	2.61	2.63	2.65	2.68	2.70	2.72	2.74	2.76	2.78
10.	2.65	2.67	2.69	2.71	2.73	2.76	2.78	2.80	2.82
9.	2.69	2.71	2.73	2.75	2.77	2.79	2.82	2.84	2.86
8.	2.73	2.75	2.77	2.79	2.81	2.83	2.85	2.88	2.90
7.	2.76	2.79	2.81	2.83	2.85	2.87	2.89	2.91	2.94
6.	2.80	2.82	2.85	2.87	2.89	2.91	2.93	2.95	2.97
5.	2.84	2.86	2.88	2.91	2.93	2.95	2.97	2.99	3.01
4.	2.88	2.90	2.92	2.95	2.97	2.99	3.01	3.03	3.05
3.	2.92	2.94	2.96	2.98	3.01	3.03	3.05	3.07	3.09
2.	2.96	2.98	3.00	3.02	3.05	3.07	3.09	3.11	3.13
1.	3.00	3.02	3.04	3.06	3.08	3.11	3.13	3.15	3.17
0.	3.04	3.06	3.08	3.10	3.12	3.15	3.17	3.19	3.21
-1.	3.08	3.10	3.12	3.14	3.16	3.19	3.21	3.23	3.25
-2.	3.12	3.14	3.16	3.18	3.20	3.22	3.25	3.27	3.29
-3.	3.16	3.18	3.20	3.22	3.24	3.26	3.29	3.31	3.33
-4.	3.20	3.22	3.24	3.26	3.28	3.30	3.33	3.35	3.37
-5.	3.24	3.26	3.28	3.30	3.32	3.34	3.37	3.39	3.41
-6.	3.28	3.30	3.32	3.34	3.36	3.39	3.41	3.43	3.45
-7.	3.32	3.34	3.36	3.38	3.40	3.43	3.45	3.47	3.49
-8.	3.36	3.38	3.40	3.42	3.44	3.47	3.49	3.51	3.53
-9.	3.40	3.42	3.44	3.46	3.48	3.51	3.53	3.55	3.57
-10.	3.44	3.46	3.48	3.50	3.53	3.55	3.57	3.59	3.61
-11.	3.48	3.50	3.52	3.54	3.57	3.59	3.61	3.63	3.65
-12.	3.52	3.54	3.56	3.58	3.61	3.63	3.65	3.67	3.70
-13.	3.56	3.58	3.60	3.63	3.65	3.67	3.69	3.71	3.74
-14.	3.60	3.62	3.65	3.67	3.69	3.71	3.73	3.76	3.78
-15.	3.64	3.66	3.69	3.71	3.73	3.75	3.78	3.80	3.82
-16.	3.68	3.71	3.73	3.75	3.77	3.79	3.82	3.84	3.86
-17.	3.72	3.75	3.77	3.79	3.81	3.84	3.86	3.88	3.90
-18.	3.77	3.79	3.81	3.83	3.86	3.88	3.90	3.92	3.94
-19.	3.81	3.83	3.85	3.88	3.90	3.92	3.94	3.96	3.99
-20.	3.85	3.87	3.89	3.92	3.94	3.96	3.98	4.01	4.03
	11.79	11.80	11.81	11.82	11.83	11.84	11.85	11.86	11.87
	Heater Resistance (Ohm) ----->								

GO TO NEXT PAGE

12.56. BLADE DE-ICE CONTROLLER ADJUSTMENT - continued

TABLE I. MAIN ROTOR BLADE ADJUSTMENT CHARTS (cont)

Blade Temp. (°C)	Main Rotor Adjustment Resistance (Kiloohm)									
	1.39	1.41	1.43	1.45	1.47	1.49	1.51	1.53	1.55	1.57
50.	1.39	1.41	1.43	1.45	1.47	1.49	1.51	1.53	1.55	1.57
49.	1.42	1.44	1.46	1.48	1.50	1.52	1.54	1.56	1.58	1.60
48.	1.46	1.48	1.50	1.52	1.54	1.56	1.58	1.60	1.62	1.64
47.	1.49	1.51	1.53	1.55	1.57	1.59	1.61	1.63	1.65	1.67
46.	1.53	1.55	1.57	1.59	1.61	1.63	1.65	1.67	1.69	1.71
45.	1.56	1.58	1.60	1.62	1.64	1.66	1.68	1.70	1.72	1.74
44.	1.60	1.62	1.64	1.66	1.68	1.70	1.72	1.74	1.76	1.78
43.	1.63	1.65	1.67	1.69	1.71	1.73	1.75	1.77	1.79	1.81
42.	1.67	1.69	1.71	1.73	1.75	1.77	1.79	1.81	1.83	1.85
41.	1.70	1.72	1.74	1.76	1.78	1.80	1.82	1.84	1.86	1.88
40.	1.74	1.76	1.78	1.80	1.82	1.84	1.86	1.88	1.90	1.92
39.	1.77	1.79	1.81	1.83	1.85	1.87	1.89	1.91	1.93	1.95
38.	1.81	1.83	1.85	1.87	1.89	1.91	1.93	1.95	1.97	1.99
37.	1.84	1.86	1.88	1.90	1.93	1.95	1.97	1.99	2.01	2.03
36.	1.88	1.90	1.92	1.94	1.96	1.98	2.00	2.02	2.04	2.06
35.	1.91	1.93	1.96	1.98	2.00	2.02	2.04	2.06	2.08	2.10
34.	1.95	1.97	1.99	2.01	2.03	2.05	2.07	2.09	2.11	2.13
33.	1.99	2.01	2.03	2.05	2.07	2.09	2.11	2.13	2.15	2.17
32.	2.02	2.04	2.06	2.08	2.10	2.13	2.15	2.17	2.19	2.21
31.	2.06	2.08	2.10	2.12	2.14	2.16	2.18	2.20	2.22	2.24
30.	2.09	2.11	2.14	2.16	2.18	2.20	2.22	2.24	2.26	2.28
29.	2.13	2.15	2.17	2.19	2.21	2.23	2.26	2.28	2.30	2.32
28.	2.17	2.19	2.21	2.23	2.25	2.27	2.29	2.31	2.33	2.35
27.	2.20	2.22	2.25	2.27	2.29	2.31	2.33	2.35	2.37	2.39
26.	2.24	2.26	2.28	2.30	2.32	2.34	2.37	2.39	2.41	2.43
25.	2.28	2.30	2.32	2.34	2.36	2.38	2.40	2.42	2.44	2.46
24.	2.31	2.33	2.36	2.38	2.40	2.42	2.44	2.46	2.48	2.50
23.	2.35	2.37	2.39	2.41	2.43	2.46	2.48	2.50	2.52	2.54
22.	2.39	2.41	2.43	2.45	2.47	2.49	2.51	2.53	2.56	2.58
21.	2.42	2.45	2.47	2.49	2.51	2.53	2.55	2.57	2.59	2.61
20.	2.46	2.48	2.50	2.53	2.55	2.57	2.59	2.61	2.63	2.65
19.	2.50	2.52	2.54	2.56	2.58	2.61	2.63	2.65	2.67	2.69
18.	2.54	2.56	2.58	2.60	2.62	2.64	2.66	2.68	2.71	2.73
17.	2.57	2.60	2.62	2.64	2.66	2.68	2.70	2.72	2.74	2.76
16.	2.61	2.63	2.65	2.68	2.70	2.72	2.74	2.76	2.78	2.80
15.	2.65	2.67	2.69	2.71	2.74	2.76	2.78	2.80	2.82	2.84
14.	2.69	2.71	2.73	2.75	2.77	2.79	2.82	2.84	2.86	2.88
13.	2.73	2.75	2.77	2.79	2.81	2.83	2.85	2.88	2.90	2.92
12.	2.76	2.79	2.81	2.83	2.85	2.87	2.89	2.91	2.94	2.96
11.	2.80	2.82	2.85	2.87	2.89	2.91	2.93	2.95	2.97	2.99
10.	2.84	2.86	2.88	2.91	2.93	2.95	2.97	2.99	3.01	3.03
9.	2.88	2.90	2.92	2.94	2.97	2.99	3.01	3.03	3.05	3.07
8.	2.92	2.94	2.96	2.98	3.00	3.03	3.05	3.07	3.09	3.11
7.	2.96	2.98	3.00	3.02	3.04	3.06	3.09	3.11	3.13	3.15
6.	3.00	3.02	3.04	3.06	3.08	3.10	3.13	3.15	3.17	3.19
5.	3.04	3.06	3.08	3.10	3.12	3.14	3.16	3.19	3.21	3.23
4.	3.07	3.10	3.12	3.14	3.16	3.18	3.20	3.23	3.25	3.27
3.	3.11	3.14	3.16	3.18	3.20	3.22	3.24	3.26	3.29	3.31
2.	3.15	3.17	3.20	3.22	3.24	3.26	3.28	3.30	3.33	3.35
1.	3.19	3.21	3.24	3.26	3.28	3.30	3.32	3.34	3.37	3.39
0.	3.23	3.25	3.28	3.30	3.32	3.34	3.36	3.38	3.41	3.43
-1.	3.27	3.29	3.32	3.34	3.36	3.38	3.40	3.42	3.45	3.47
-2.	3.31	3.33	3.36	3.38	3.40	3.42	3.44	3.46	3.49	3.51
-3.	3.35	3.37	3.40	3.42	3.44	3.46	3.48	3.50	3.53	3.55
-4.	3.39	3.41	3.44	3.46	3.48	3.50	3.52	3.54	3.57	3.59
-5.	3.43	3.45	3.48	3.50	3.52	3.54	3.56	3.59	3.61	3.63
-6.	3.47	3.49	3.52	3.54	3.56	3.58	3.60	3.63	3.65	3.67
-7.	3.51	3.54	3.56	3.58	3.60	3.62	3.64	3.67	3.69	3.71
-8.	3.55	3.58	3.60	3.62	3.64	3.66	3.69	3.71	3.73	3.75
-9.	3.59	3.62	3.64	3.66	3.68	3.70	3.73	3.75	3.77	3.79
-10.	3.64	3.66	3.68	3.70	3.72	3.75	3.77	3.79	3.81	3.83
-11.	3.68	3.70	3.72	3.74	3.76	3.79	3.81	3.83	3.85	3.87
-12.	3.72	3.74	3.76	3.78	3.81	3.83	3.85	3.87	3.89	3.91
-13.	3.76	3.78	3.80	3.83	3.85	3.87	3.89	3.91	3.94	3.96
-14.	3.80	3.82	3.84	3.87	3.89	3.91	3.93	3.96	3.98	4.00
-15.	3.84	3.86	3.89	3.91	3.93	3.95	3.98	4.00	4.02	4.04
-16.	3.88	3.91	3.93	3.95	3.97	3.99	4.02	4.04	4.06	4.08
-17.	3.93	3.95	3.97	3.99	4.01	4.04	4.06	4.08	4.10	4.12
-18.	3.97	3.99	4.01	4.03	4.06	4.08	4.10	4.12	4.15	4.17
-19.	4.01	4.03	4.05	4.08	4.10	4.12	4.14	4.17	4.19	4.21
-20.	4.05	4.07	4.10	4.12	4.14	4.16	4.19	4.21	4.23	4.25
	11.88	11.89	11.90	11.91	11.92	11.93	11.94	11.95	11.96	11.96

Heater Resistance (Ohm) ----->

GO TO NEXT PAGE

12.56. BLADE DE-ICE CONTROLLER ADJUSTMENT - continued

TABLE I. MAIN ROTOR BLADE ADJUSTMENT CHARTS (cont)

Blade Temp. (°C)	Main Rotor Adjustment Resistance (Kiloohm)									
	1.57	1.59	1.61	1.63	1.65	1.67	1.69	1.71	1.73	1.75
50.	1.57	1.59	1.61	1.63	1.65	1.67	1.69	1.71	1.73	1.75
49.	1.61	1.63	1.65	1.67	1.69	1.71	1.73	1.75	1.77	1.79
48.	1.64	1.66	1.68	1.70	1.72	1.74	1.76	1.78	1.80	1.82
47.	1.67	1.70	1.72	1.74	1.76	1.78	1.80	1.82	1.84	1.86
46.	1.71	1.73	1.75	1.77	1.79	1.81	1.83	1.85	1.87	1.89
45.	1.74	1.76	1.79	1.81	1.83	1.85	1.87	1.89	1.91	1.93
44.	1.78	1.80	1.82	1.84	1.86	1.88	1.90	1.92	1.94	1.96
43.	1.81	1.84	1.86	1.88	1.90	1.92	1.94	1.96	1.98	2.00
42.	1.85	1.87	1.89	1.91	1.93	1.95	1.97	1.99	2.01	2.03
41.	1.89	1.91	1.93	1.95	1.97	1.99	2.01	2.03	2.05	2.07
40.	1.92	1.94	1.96	1.98	2.00	2.02	2.04	2.06	2.08	2.10
39.	1.96	1.98	2.00	2.02	2.04	2.06	2.08	2.10	2.12	2.14
38.	1.99	2.01	2.03	2.05	2.07	2.09	2.11	2.13	2.15	2.17
37.	2.03	2.05	2.07	2.09	2.11	2.13	2.15	2.17	2.19	2.21
36.	2.06	2.08	2.10	2.12	2.14	2.16	2.18	2.20	2.22	2.24
35.	2.10	2.12	2.14	2.16	2.18	2.20	2.22	2.24	2.26	2.28
34.	2.14	2.16	2.18	2.20	2.22	2.24	2.26	2.28	2.30	2.32
33.	2.17	2.19	2.21	2.23	2.25	2.27	2.29	2.31	2.33	2.35
32.	2.21	2.23	2.25	2.27	2.29	2.31	2.33	2.35	2.37	2.39
31.	2.24	2.27	2.29	2.31	2.33	2.35	2.37	2.39	2.41	2.43
30.	2.28	2.30	2.32	2.34	2.36	2.38	2.40	2.42	2.44	2.46
29.	2.32	2.34	2.36	2.38	2.40	2.42	2.44	2.46	2.48	2.50
28.	2.35	2.37	2.40	2.42	2.44	2.46	2.48	2.50	2.52	2.54
27.	2.39	2.41	2.43	2.45	2.47	2.50	2.52	2.54	2.56	2.58
26.	2.43	2.45	2.47	2.49	2.51	2.53	2.55	2.57	2.59	2.61
25.	2.46	2.49	2.51	2.53	2.55	2.57	2.59	2.61	2.63	2.65
24.	2.50	2.52	2.54	2.56	2.59	2.61	2.63	2.65	2.67	2.69
23.	2.54	2.56	2.58	2.60	2.62	2.64	2.66	2.69	2.71	2.73
22.	2.58	2.60	2.62	2.64	2.66	2.68	2.70	2.72	2.74	2.76
21.	2.61	2.64	2.66	2.68	2.70	2.72	2.74	2.76	2.78	2.80
20.	2.65	2.67	2.69	2.71	2.74	2.76	2.78	2.80	2.82	2.84
19.	2.69	2.71	2.73	2.75	2.77	2.79	2.82	2.84	2.86	2.88
18.	2.73	2.75	2.77	2.79	2.81	2.83	2.85	2.87	2.89	2.91
17.	2.77	2.79	2.81	2.83	2.85	2.87	2.89	2.91	2.93	2.95
16.	2.80	2.82	2.85	2.87	2.89	2.91	2.93	2.95	2.97	2.99
15.	2.84	2.86	2.88	2.90	2.93	2.95	2.97	2.99	3.01	3.03
14.	2.88	2.90	2.92	2.94	2.96	2.99	3.01	3.03	3.05	3.07
13.	2.92	2.94	2.96	2.98	3.00	3.02	3.05	3.07	3.09	3.11
12.	2.96	2.98	3.00	3.02	3.04	3.06	3.08	3.11	3.13	3.15
11.	3.00	3.02	3.04	3.06	3.08	3.10	3.12	3.14	3.17	3.19
10.	3.03	3.06	3.08	3.10	3.12	3.14	3.16	3.18	3.20	3.22
9.	3.07	3.09	3.12	3.14	3.16	3.18	3.20	3.22	3.24	3.26
8.	3.11	3.13	3.15	3.18	3.20	3.22	3.24	3.26	3.28	3.30
7.	3.15	3.17	3.19	3.22	3.24	3.26	3.28	3.30	3.32	3.34
6.	3.19	3.21	3.23	3.25	3.28	3.30	3.32	3.34	3.36	3.38
5.	3.23	3.25	3.27	3.29	3.32	3.34	3.36	3.38	3.40	3.42
4.	3.27	3.29	3.31	3.33	3.35	3.38	3.40	3.42	3.44	3.46
3.	3.31	3.33	3.35	3.37	3.39	3.42	3.44	3.46	3.48	3.50
2.	3.35	3.37	3.39	3.41	3.43	3.46	3.48	3.50	3.52	3.54
1.	3.39	3.41	3.43	3.45	3.47	3.50	3.52	3.54	3.56	3.58
0.	3.43	3.45	3.47	3.49	3.51	3.54	3.56	3.58	3.60	3.62
-1.	3.47	3.49	3.51	3.53	3.55	3.58	3.60	3.62	3.64	3.66
-2.	3.51	3.53	3.55	3.57	3.59	3.62	3.64	3.66	3.68	3.70
-3.	3.55	3.57	3.59	3.61	3.64	3.66	3.68	3.70	3.72	3.74
-4.	3.59	3.61	3.63	3.65	3.68	3.70	3.72	3.74	3.76	3.78
-5.	3.63	3.65	3.67	3.69	3.72	3.74	3.76	3.78	3.80	3.82
-6.	3.67	3.69	3.71	3.74	3.76	3.78	3.80	3.82	3.84	3.86
-7.	3.71	3.73	3.75	3.78	3.80	3.82	3.84	3.86	3.88	3.91
-8.	3.75	3.77	3.80	3.82	3.84	3.86	3.88	3.91	3.93	3.95
-9.	3.79	3.81	3.84	3.86	3.88	3.90	3.92	3.95	3.97	4.01
-10.	3.83	3.86	3.88	3.90	3.92	3.94	3.97	3.99	4.01	4.05
-11.	3.88	3.90	3.92	3.94	3.96	3.99	4.01	4.03	4.05	4.09
-12.	3.92	3.94	3.96	3.98	4.00	4.03	4.05	4.07	4.09	4.11
-13.	3.96	3.98	4.00	4.02	4.05	4.07	4.09	4.11	4.14	4.16
-14.	4.00	4.02	4.04	4.07	4.09	4.11	4.13	4.15	4.18	4.20
-15.	4.04	4.06	4.09	4.11	4.13	4.15	4.17	4.20	4.22	4.24
-16.	4.08	4.11	4.13	4.15	4.17	4.19	4.22	4.24	4.26	4.28
-17.	4.13	4.15	4.17	4.19	4.21	4.24	4.26	4.28	4.30	4.32
-18.	4.17	4.19	4.21	4.23	4.26	4.28	4.30	4.32	4.34	4.35
-19.	4.21	4.23	4.25	4.28	4.30	4.32	4.34	4.37	4.39	4.41
-20.	4.25	4.28	4.30	4.32	4.34	4.36	4.39	4.41	4.43	4.45
	11.97	11.98	11.99	12.00	12.01	12.02	12.03	12.04	12.05	
	Heater Resistance (Ohm) ----->									

GO TO NEXT PAGE



12.56. BLADE DE-ICE CONTROLLER ADJUSTMENT - continued

TABLE I. MAIN ROTOR BLADE ADJUSTMENT CHARTS (cont)

Blade Temp. (°C)	Main Rotor Adjustment Resistance (Kiloohm)									
	1.75	1.77	1.79	1.81	1.83	1.85	1.87	1.89	1.91	1.93
50.	1.75	1.77	1.79	1.81	1.83	1.85	1.87	1.89	1.91	1.93
49.	1.79	1.81	1.83	1.85	1.87	1.89	1.91	1.93	1.95	1.97
48.	1.82	1.84	1.86	1.88	1.90	1.92	1.94	1.96	1.98	2.00
47.	1.86	1.88	1.90	1.92	1.94	1.96	1.98	2.00	2.02	2.04
46.	1.89	1.91	1.93	1.95	1.97	1.99	2.01	2.03	2.05	2.07
45.	1.93	1.95	1.97	1.99	2.01	2.03	2.05	2.07	2.09	2.11
44.	1.96	1.98	2.00	2.02	2.04	2.06	2.08	2.10	2.12	2.14
43.	2.00	2.02	2.04	2.06	2.08	2.10	2.12	2.14	2.16	2.18
42.	2.03	2.05	2.07	2.09	2.11	2.13	2.15	2.17	2.19	2.21
41.	2.07	2.09	2.11	2.13	2.15	2.17	2.19	2.21	2.23	2.25
40.	2.10	2.13	2.15	2.17	2.19	2.21	2.23	2.25	2.27	2.29
39.	2.14	2.16	2.18	2.20	2.22	2.24	2.26	2.28	2.30	2.32
38.	2.18	2.20	2.22	2.24	2.26	2.28	2.30	2.32	2.34	2.36
37.	2.21	2.23	2.25	2.27	2.29	2.31	2.33	2.35	2.37	2.39
36.	2.25	2.27	2.29	2.31	2.33	2.35	2.37	2.39	2.41	2.43
35.	2.28	2.31	2.33	2.35	2.37	2.39	2.41	2.43	2.45	2.47
34.	2.32	2.34	2.36	2.38	2.40	2.42	2.44	2.46	2.48	2.50
33.	2.36	2.38	2.40	2.42	2.44	2.46	2.48	2.50	2.52	2.54
32.	2.39	2.41	2.43	2.45	2.47	2.49	2.51	2.53	2.55	2.57
31.	2.43	2.45	2.47	2.49	2.51	2.53	2.55	2.57	2.59	2.61
30.	2.47	2.49	2.51	2.53	2.55	2.57	2.59	2.61	2.63	2.65
29.	2.50	2.53	2.55	2.57	2.59	2.61	2.63	2.65	2.67	2.69
28.	2.54	2.56	2.58	2.60	2.62	2.64	2.66	2.68	2.70	2.72
27.	2.58	2.60	2.62	2.64	2.66	2.68	2.70	2.72	2.74	2.76
26.	2.62	2.64	2.66	2.68	2.70	2.72	2.74	2.76	2.78	2.80
25.	2.65	2.67	2.69	2.71	2.73	2.75	2.77	2.79	2.81	2.83
24.	2.69	2.71	2.73	2.75	2.77	2.79	2.81	2.83	2.85	2.87
23.	2.73	2.75	2.77	2.79	2.81	2.83	2.85	2.87	2.89	2.91
22.	2.77	2.79	2.81	2.83	2.85	2.87	2.89	2.91	2.93	2.95
21.	2.80	2.82	2.84	2.86	2.88	2.90	2.92	2.94	2.96	2.98
20.	2.84	2.86	2.88	2.90	2.92	2.94	2.96	2.98	3.00	3.02
19.	2.88	2.90	2.92	2.94	2.96	2.98	3.00	3.02	3.04	3.06
18.	2.92	2.94	2.96	2.98	3.00	3.02	3.04	3.06	3.08	3.10
17.	2.96	2.98	3.00	3.02	3.04	3.06	3.08	3.10	3.12	3.14
16.	2.99	3.01	3.03	3.05	3.07	3.09	3.11	3.13	3.15	3.17
15.	3.03	3.05	3.07	3.09	3.11	3.13	3.15	3.17	3.19	3.21
14.	3.07	3.09	3.11	3.13	3.15	3.17	3.19	3.21	3.23	3.25
13.	3.11	3.13	3.15	3.17	3.19	3.21	3.23	3.25	3.27	3.29
12.	3.15	3.17	3.19	3.21	3.23	3.25	3.27	3.29	3.31	3.33
11.	3.19	3.21	3.23	3.25	3.27	3.29	3.31	3.33	3.35	3.37
10.	3.23	3.25	3.27	3.29	3.31	3.33	3.35	3.37	3.39	3.41
9.	3.27	3.29	3.31	3.33	3.35	3.37	3.39	3.41	3.43	3.45
8.	3.30	3.33	3.35	3.37	3.39	3.41	3.43	3.45	3.47	3.49
7.	3.34	3.37	3.39	3.41	3.43	3.45	3.47	3.49	3.51	3.53
6.	3.38	3.40	3.43	3.45	3.47	3.49	3.51	3.53	3.55	3.57
5.	3.42	3.44	3.47	3.49	3.51	3.53	3.55	3.57	3.59	3.61
4.	3.46	3.48	3.51	3.53	3.55	3.57	3.59	3.61	3.63	3.65
3.	3.50	3.52	3.55	3.57	3.59	3.61	3.63	3.65	3.67	3.69
2.	3.54	3.56	3.59	3.61	3.63	3.65	3.67	3.69	3.71	3.73
1.	3.58	3.60	3.63	3.65	3.67	3.69	3.71	3.73	3.75	3.77
0.	3.62	3.64	3.67	3.69	3.71	3.73	3.75	3.77	3.79	3.81
-1.	3.66	3.68	3.71	3.73	3.75	3.77	3.79	3.81	3.83	3.85
-2.	3.70	3.73	3.75	3.77	3.79	3.81	3.83	3.85	3.87	3.89
-3.	3.74	3.77	3.79	3.81	3.83	3.85	3.87	3.89	3.91	3.93
-4.	3.78	3.81	3.83	3.85	3.87	3.89	3.91	3.93	3.95	3.97
-5.	3.83	3.85	3.87	3.89	3.91	3.93	3.95	3.97	3.99	4.01
-6.	3.87	3.89	3.91	3.93	3.95	3.97	3.99	4.01	4.03	4.05
-7.	3.91	3.93	3.95	3.97	3.99	4.01	4.03	4.05	4.07	4.09
-8.	3.95	3.97	3.99	4.01	4.03	4.05	4.07	4.09	4.11	4.13
-9.	3.99	4.01	4.03	4.05	4.07	4.09	4.11	4.13	4.15	4.17
-10.	4.03	4.05	4.07	4.09	4.11	4.13	4.15	4.17	4.19	4.21
-11.	4.07	4.10	4.12	4.14	4.16	4.18	4.20	4.22	4.24	4.26
-12.	4.12	4.14	4.16	4.18	4.20	4.22	4.24	4.26	4.28	4.30
-13.	4.16	4.18	4.20	4.22	4.24	4.26	4.28	4.30	4.32	4.34
-14.	4.20	4.22	4.24	4.26	4.28	4.30	4.32	4.34	4.36	4.38
-15.	4.24	4.26	4.28	4.30	4.32	4.34	4.36	4.38	4.40	4.42
-16.	4.28	4.31	4.33	4.35	4.37	4.39	4.41	4.43	4.45	4.47
-17.	4.33	4.35	4.37	4.39	4.41	4.43	4.45	4.47	4.49	4.51
-18.	4.37	4.39	4.41	4.43	4.45	4.47	4.49	4.51	4.53	4.55
-19.	4.41	4.43	4.45	4.47	4.49	4.51	4.53	4.55	4.57	4.59
-20.	4.45	4.48	4.50	4.52	4.54	4.56	4.58	4.60	4.62	4.64
	12.06	12.07	12.08	12.09	12.10	12.11	12.12	12.13	12.14	

Heater Resistance (Ohm) ----->

GO TO NEXT PAGE

12.56. BLADE DE-ICE CONTROLLER ADJUSTMENT - continued

TABLE I. MAIN ROTOR BLADE ADJUSTMENT CHARTS (cont)

Blade Temp. (°C)	Main Rotor Adjustment Resistance (Kiloohm)									
	12.15	12.16	12.17	12.18	12.19	12.20	12.21	12.22	12.23	12.23
50.	1.93	1.95	1.97	1.99	2.01	2.03	2.05	2.07	2.09	2.11
49.	1.97	1.99	2.01	2.03	2.05	2.07	2.09	2.11	2.13	2.15
48.	2.00	2.02	2.04	2.06	2.08	2.10	2.12	2.14	2.16	2.17
47.	2.04	2.06	2.08	2.10	2.12	2.14	2.16	2.18	2.20	2.20
46.	2.07	2.09	2.11	2.14	2.16	2.18	2.20	2.22	2.24	2.24
45.	2.11	2.13	2.15	2.17	2.19	2.21	2.23	2.25	2.27	2.27
44.	2.15	2.17	2.19	2.21	2.23	2.25	2.27	2.29	2.31	2.31
43.	2.18	2.20	2.22	2.24	2.26	2.28	2.30	2.32	2.34	2.34
42.	2.22	2.24	2.26	2.28	2.30	2.32	2.34	2.36	2.38	2.38
41.	2.25	2.27	2.29	2.31	2.33	2.35	2.38	2.40	2.42	2.42
40.	2.29	2.31	2.33	2.35	2.37	2.39	2.41	2.43	2.45	2.45
39.	2.32	2.35	2.37	2.39	2.41	2.43	2.45	2.47	2.49	2.49
38.	2.36	2.38	2.40	2.42	2.44	2.46	2.48	2.50	2.52	2.52
37.	2.40	2.42	2.44	2.46	2.48	2.50	2.52	2.54	2.56	2.56
36.	2.43	2.45	2.47	2.50	2.52	2.54	2.56	2.58	2.60	2.60
35.	2.47	2.49	2.51	2.53	2.55	2.57	2.59	2.61	2.63	2.63
34.	2.51	2.53	2.55	2.57	2.59	2.61	2.63	2.65	2.67	2.67
33.	2.54	2.56	2.58	2.61	2.63	2.65	2.67	2.69	2.71	2.71
32.	2.58	2.60	2.62	2.64	2.66	2.68	2.70	2.72	2.75	2.75
31.	2.62	2.64	2.66	2.68	2.70	2.72	2.74	2.76	2.78	2.78
30.	2.65	2.67	2.70	2.72	2.74	2.76	2.78	2.80	2.82	2.82
29.	2.69	2.71	2.73	2.75	2.77	2.80	2.82	2.84	2.86	2.86
28.	2.73	2.75	2.77	2.79	2.81	2.83	2.85	2.87	2.89	2.89
27.	2.77	2.79	2.81	2.83	2.85	2.87	2.89	2.91	2.93	2.93
26.	2.80	2.82	2.85	2.87	2.89	2.91	2.93	2.95	2.97	2.97
25.	2.84	2.86	2.88	2.90	2.92	2.95	2.97	2.99	3.01	3.01
24.	2.88	2.90	2.92	2.94	2.96	2.98	3.00	3.03	3.05	3.05
23.	2.92	2.94	2.96	2.98	3.00	3.02	3.04	3.06	3.08	3.08
22.	2.95	2.98	3.00	3.02	3.04	3.06	3.08	3.10	3.12	3.12
21.	2.99	3.01	3.03	3.06	3.08	3.10	3.12	3.14	3.16	3.16
20.	3.03	3.05	3.07	3.09	3.11	3.14	3.16	3.18	3.20	3.20
19.	3.07	3.09	3.11	3.13	3.15	3.17	3.20	3.22	3.24	3.24
18.	3.11	3.13	3.15	3.17	3.19	3.21	3.23	3.25	3.28	3.28
17.	3.15	3.17	3.19	3.21	3.23	3.25	3.27	3.29	3.31	3.31
16.	3.18	3.21	3.23	3.25	3.27	3.29	3.31	3.33	3.35	3.35
15.	3.22	3.24	3.27	3.29	3.31	3.33	3.35	3.37	3.39	3.39
14.	3.26	3.28	3.30	3.33	3.35	3.37	3.39	3.41	3.43	3.43
13.	3.30	3.32	3.34	3.36	3.39	3.41	3.43	3.45	3.47	3.47
12.	3.34	3.36	3.38	3.40	3.42	3.45	3.47	3.49	3.51	3.51
11.	3.38	3.40	3.42	3.44	3.46	3.49	3.51	3.53	3.55	3.55
10.	3.42	3.44	3.46	3.48	3.50	3.53	3.55	3.57	3.59	3.59
9.	3.46	3.48	3.50	3.52	3.54	3.56	3.59	3.61	3.63	3.63
8.	3.50	3.52	3.54	3.56	3.58	3.60	3.63	3.65	3.67	3.67
7.	3.54	3.56	3.58	3.60	3.62	3.64	3.67	3.69	3.71	3.71
6.	3.58	3.60	3.62	3.64	3.66	3.68	3.71	3.73	3.75	3.75
5.	3.62	3.64	3.66	3.68	3.70	3.72	3.75	3.77	3.79	3.79
4.	3.66	3.68	3.70	3.72	3.74	3.76	3.79	3.81	3.83	3.83
3.	3.70	3.72	3.74	3.76	3.78	3.80	3.83	3.85	3.87	3.87
2.	3.74	3.76	3.78	3.80	3.82	3.85	3.87	3.89	3.91	3.91
1.	3.78	3.80	3.82	3.84	3.86	3.89	3.91	3.93	3.95	3.95
0.	3.82	3.84	3.86	3.88	3.90	3.93	3.95	3.97	3.99	3.99
-1.	3.86	3.88	3.90	3.92	3.95	3.97	3.99	4.01	4.03	4.03
-2.	3.90	3.92	3.94	3.96	3.99	4.01	4.03	4.05	4.07	4.07
-3.	3.94	3.96	3.98	4.01	4.03	4.05	4.07	4.09	4.11	4.11
-4.	3.98	4.00	4.03	4.05	4.07	4.09	4.11	4.13	4.16	4.16
-5.	4.02	4.04	4.07	4.09	4.11	4.13	4.15	4.18	4.20	4.20
-6.	4.06	4.09	4.11	4.13	4.15	4.17	4.20	4.22	4.24	4.24
-7.	4.11	4.13	4.15	4.17	4.19	4.21	4.24	4.26	4.28	4.28
-8.	4.15	4.17	4.19	4.21	4.23	4.26	4.28	4.30	4.32	4.32
-9.	4.19	4.21	4.23	4.25	4.28	4.30	4.32	4.34	4.36	4.36
-10.	4.23	4.25	4.27	4.30	4.32	4.34	4.36	4.38	4.41	4.41
-11.	4.27	4.29	4.32	4.34	4.36	4.38	4.40	4.43	4.45	4.45
-12.	4.31	4.34	4.36	4.38	4.40	4.42	4.45	4.47	4.49	4.49
-13.	4.36	4.38	4.40	4.42	4.45	4.47	4.49	4.51	4.53	4.53
-14.	4.40	4.42	4.44	4.47	4.49	4.51	4.53	4.55	4.58	4.58
-15.	4.44	4.46	4.49	4.51	4.53	4.55	4.57	4.60	4.62	4.62
-16.	4.48	4.51	4.53	4.55	4.57	4.60	4.62	4.64	4.66	4.66
-17.	4.53	4.55	4.57	4.59	4.62	4.64	4.66	4.68	4.70	4.70
-18.	4.57	4.59	4.61	4.64	4.66	4.68	4.70	4.73	4.75	4.75
-19.	4.61	4.63	4.66	4.68	4.70	4.72	4.75	4.77	4.79	4.79
-20.	4.66	4.68	4.70	4.72	4.75	4.77	4.79	4.81	4.83	4.83

Heater Resistance (Ohm) ----->

GO TO NEXT PAGE

12.56. BLADE DE-ICE CONTROLLER ADJUSTMENT - continued

TABLE I. MAIN ROTOR BLADE ADJUSTMENT CHARTS (cont)

Blade Temp. (°C)	Main Rotor Adjustment Resistance (Kiloohm)									
	2.11	2.13	2.16	2.18	2.20	2.22	2.24	2.26	2.28	
50.	2.11	2.13	2.16	2.18	2.20	2.22	2.24	2.26	2.28	
49.	2.15	2.17	2.19	2.21	2.23	2.25	2.27	2.29	2.31	
48.	2.19	2.21	2.23	2.25	2.27	2.29	2.31	2.33	2.35	
47.	2.22	2.24	2.26	2.28	2.30	2.32	2.34	2.36	2.38	
46.	2.26	2.28	2.30	2.32	2.34	2.36	2.38	2.40	2.42	
45.	2.29	2.31	2.33	2.35	2.37	2.39	2.41	2.43	2.45	
44.	2.33	2.35	2.37	2.39	2.41	2.43	2.45	2.47	2.49	
43.	2.36	2.38	2.40	2.43	2.45	2.47	2.49	2.51	2.53	
42.	2.40	2.42	2.44	2.46	2.48	2.50	2.52	2.54	2.56	
41.	2.44	2.46	2.48	2.50	2.52	2.54	2.56	2.58	2.60	
40.	2.47	2.49	2.51	2.53	2.55	2.57	2.60	2.62	2.64	
39.	2.51	2.53	2.55	2.57	2.59	2.61	2.63	2.65	2.67	
38.	2.55	2.57	2.59	2.61	2.63	2.65	2.67	2.69	2.71	
37.	2.58	2.60	2.62	2.64	2.66	2.68	2.70	2.73	2.75	
36.	2.62	2.64	2.66	2.68	2.70	2.72	2.74	2.76	2.78	
35.	2.66	2.68	2.70	2.72	2.74	2.76	2.78	2.80	2.82	
34.	2.69	2.71	2.73	2.75	2.77	2.80	2.82	2.84	2.86	
33.	2.73	2.75	2.77	2.79	2.81	2.83	2.85	2.87	2.89	
32.	2.77	2.79	2.81	2.83	2.85	2.87	2.89	2.91	2.93	
31.	2.80	2.82	2.84	2.87	2.89	2.91	2.93	2.95	2.97	
30.	2.84	2.86	2.88	2.90	2.92	2.94	2.97	2.99	3.01	
29.	2.88	2.90	2.92	2.94	2.96	2.98	3.00	3.02	3.04	
28.	2.92	2.94	2.96	2.98	3.00	3.02	3.04	3.06	3.08	
27.	2.95	2.97	2.99	3.02	3.04	3.06	3.08	3.10	3.12	
26.	2.99	3.01	3.03	3.05	3.07	3.10	3.12	3.14	3.16	
25.	3.03	3.05	3.07	3.09	3.11	3.13	3.15	3.18	3.20	
24.	3.07	3.09	3.11	3.13	3.15	3.17	3.19	3.21	3.23	
23.	3.10	3.13	3.15	3.17	3.19	3.21	3.23	3.25	3.27	
22.	3.14	3.16	3.19	3.21	3.23	3.25	3.27	3.29	3.31	
21.	3.18	3.20	3.22	3.24	3.27	3.29	3.31	3.33	3.35	
20.	3.22	3.24	3.26	3.28	3.30	3.33	3.35	3.37	3.39	
19.	3.26	3.28	3.30	3.32	3.34	3.36	3.38	3.41	3.43	
18.	3.30	3.32	3.34	3.36	3.38	3.40	3.42	3.44	3.47	
17.	3.34	3.36	3.38	3.40	3.42	3.44	3.46	3.48	3.50	
16.	3.37	3.40	3.42	3.44	3.46	3.48	3.50	3.52	3.54	
15.	3.41	3.43	3.46	3.48	3.50	3.52	3.54	3.56	3.58	
14.	3.45	3.47	3.50	3.52	3.54	3.56	3.58	3.60	3.62	
13.	3.49	3.51	3.53	3.56	3.58	3.60	3.62	3.64	3.66	
12.	3.53	3.55	3.57	3.60	3.62	3.64	3.66	3.68	3.70	
11.	3.57	3.59	3.61	3.63	3.66	3.68	3.70	3.72	3.74	
10.	3.61	3.63	3.65	3.67	3.70	3.72	3.74	3.76	3.78	
9.	3.65	3.67	3.69	3.71	3.74	3.76	3.78	3.80	3.82	
8.	3.69	3.71	3.73	3.75	3.78	3.80	3.82	3.84	3.86	
7.	3.73	3.75	3.77	3.79	3.82	3.84	3.86	3.88	3.90	
6.	3.77	3.79	3.81	3.83	3.86	3.88	3.90	3.92	3.94	
5.	3.81	3.83	3.85	3.87	3.90	3.92	3.94	3.96	3.98	
4.	3.85	3.87	3.89	3.92	3.94	3.96	3.98	4.00	4.02	
3.	3.89	3.91	3.93	3.96	3.98	4.00	4.02	4.04	4.06	
2.	3.93	3.95	3.98	4.00	4.02	4.04	4.06	4.08	4.10	
1.	3.97	3.99	4.02	4.04	4.06	4.08	4.10	4.12	4.15	
0.	4.01	4.03	4.06	4.08	4.10	4.12	4.14	4.17	4.19	
-1.	4.05	4.08	4.10	4.12	4.14	4.16	4.18	4.21	4.23	
-2.	4.10	4.12	4.14	4.16	4.18	4.20	4.23	4.25	4.27	
-3.	4.14	4.16	4.18	4.20	4.22	4.25	4.27	4.29	4.31	
-4.	4.18	4.20	4.22	4.24	4.27	4.29	4.31	4.33	4.35	
-5.	4.22	4.24	4.26	4.28	4.31	4.33	4.35	4.37	4.39	
-6.	4.26	4.28	4.30	4.33	4.35	4.37	4.39	4.41	4.44	
-7.	4.30	4.32	4.35	4.37	4.39	4.41	4.43	4.46	4.48	
-8.	4.34	4.37	4.39	4.41	4.43	4.45	4.48	4.50	4.52	
-9.	4.39	4.41	4.43	4.45	4.47	4.50	4.52	4.54	4.56	
-10.	4.43	4.45	4.47	4.49	4.52	4.54	4.56	4.58	4.60	
-11.	4.47	4.49	4.51	4.54	4.56	4.58	4.60	4.63	4.65	
-12.	4.51	4.54	4.56	4.58	4.60	4.62	4.65	4.67	4.69	
-13.	4.56	4.58	4.60	4.62	4.64	4.67	4.69	4.71	4.73	
-14.	4.60	4.62	4.64	4.66	4.69	4.71	4.73	4.75	4.78	
-15.	4.64	4.66	4.69	4.71	4.73	4.75	4.77	4.80	4.82	
-16.	4.68	4.71	4.73	4.75	4.77	4.80	4.82	4.84	4.86	
-17.	4.73	4.75	4.77	4.79	4.82	4.84	4.86	4.88	4.91	
-18.	4.77	4.79	4.81	4.84	4.86	4.88	4.90	4.93	4.95	
-19.	4.81	4.84	4.86	4.88	4.90	4.93	4.95	4.97	4.99	
-20.	4.86	4.88	4.90	4.92	4.95	4.97	4.99			
	12.24	12.25	12.26	12.27	12.28	12.29	12.30	12.31	12.32	
	Heater Resistance (Ohm) ----->									

GO TO NEXT PAGE

12.56. BLADE DE-ICE CONTROLLER ADJUSTMENT - continued

TABLE I. MAIN ROTOR BLADE ADJUSTMENT CHARTS (cont)

Blade Temp. (°C)	Main Rotor Adjustment Resistance (Kiloohm)								
	2.30	2.32	2.34	2.36	2.38	2.40	2.42	2.44	2.46
50.	2.33	2.35	2.37	2.39	2.41	2.43	2.45	2.47	2.49
49.	2.37	2.39	2.41	2.43	2.45	2.47	2.49	2.51	2.53
48.	2.40	2.42	2.44	2.46	2.48	2.50	2.52	2.54	2.56
47.	2.44	2.46	2.48	2.50	2.52	2.54	2.56	2.58	2.60
46.	2.47	2.50	2.52	2.54	2.56	2.58	2.60	2.62	2.64
45.	2.51	2.53	2.55	2.57	2.59	2.61	2.63	2.65	2.67
44.	2.55	2.57	2.59	2.61	2.63	2.65	2.67	2.69	2.71
43.	2.58	2.60	2.62	2.64	2.67	2.69	2.71	2.73	2.75
42.	2.62	2.64	2.66	2.68	2.70	2.72	2.74	2.76	2.78
41.	2.66	2.68	2.70	2.72	2.74	2.76	2.78	2.80	2.82
40.	2.69	2.71	2.73	2.75	2.77	2.80	2.82	2.84	2.86
39.	2.73	2.75	2.77	2.79	2.81	2.83	2.85	2.87	2.89
38.	2.77	2.79	2.81	2.83	2.85	2.87	2.89	2.91	2.93
37.	2.80	2.82	2.84	2.87	2.89	2.91	2.93	2.95	2.97
36.	2.84	2.86	2.88	2.90	2.92	2.94	2.96	2.98	3.01
35.	2.88	2.90	2.92	2.94	2.96	2.98	3.00	3.02	3.04
34.	2.91	2.94	2.96	2.98	3.00	3.02	3.04	3.06	3.08
33.	2.95	2.97	2.99	3.01	3.03	3.06	3.08	3.10	3.12
32.	2.99	3.01	3.03	3.05	3.07	3.09	3.11	3.13	3.16
31.	3.03	3.05	3.07	3.09	3.11	3.13	3.15	3.17	3.19
30.	3.06	3.09	3.11	3.13	3.15	3.17	3.19	3.21	3.23
29.	3.10	3.12	3.14	3.17	3.19	3.21	3.23	3.25	3.27
28.	3.14	3.16	3.18	3.20	3.22	3.24	3.27	3.29	3.31
27.	3.18	3.20	3.22	3.24	3.26	3.28	3.30	3.32	3.35
26.	3.22	3.24	3.26	3.28	3.30	3.32	3.34	3.36	3.38
25.	3.26	3.28	3.30	3.32	3.34	3.36	3.38	3.40	3.42
24.	3.29	3.31	3.34	3.36	3.38	3.40	3.42	3.44	3.46
23.	3.33	3.35	3.37	3.39	3.42	3.44	3.46	3.48	3.50
22.	3.37	3.39	3.41	3.43	3.45	3.48	3.50	3.52	3.54
21.	3.41	3.43	3.45	3.47	3.49	3.51	3.54	3.56	3.58
20.	3.45	3.47	3.49	3.51	3.53	3.55	3.57	3.60	3.62
19.	3.49	3.51	3.53	3.55	3.57	3.59	3.61	3.63	3.66
18.	3.53	3.55	3.57	3.59	3.61	3.63	3.65	3.67	3.70
17.	3.57	3.59	3.61	3.63	3.65	3.67	3.69	3.71	3.73
16.	3.60	3.63	3.65	3.67	3.69	3.71	3.73	3.75	3.77
15.	3.64	3.67	3.69	3.71	3.73	3.75	3.77	3.79	3.81
14.	3.68	3.70	3.73	3.75	3.77	3.79	3.81	3.83	3.85
13.	3.72	3.74	3.77	3.79	3.81	3.83	3.85	3.87	3.89
12.	3.76	3.78	3.81	3.83	3.85	3.87	3.89	3.91	3.93
11.	3.80	3.82	3.85	3.87	3.89	3.91	3.93	3.95	3.97
10.	3.84	3.86	3.89	3.91	3.93	3.95	3.97	3.99	4.01
9.	3.88	3.90	3.93	3.95	3.97	3.99	4.01	4.03	4.05
8.	3.92	3.94	3.97	3.99	4.01	4.03	4.05	4.07	4.09
7.	3.96	3.99	4.01	4.03	4.05	4.07	4.09	4.11	4.13
6.	4.00	4.03	4.05	4.07	4.09	4.11	4.13	4.15	4.18
5.	4.04	4.07	4.09	4.11	4.13	4.15	4.17	4.20	4.22
4.	4.09	4.11	4.13	4.15	4.17	4.19	4.22	4.24	4.26
3.	4.13	4.15	4.17	4.19	4.21	4.23	4.26	4.28	4.30
2.	4.17	4.19	4.21	4.23	4.25	4.28	4.30	4.32	4.34
1.	4.21	4.23	4.25	4.27	4.30	4.32	4.34	4.36	4.38
0.	4.25	4.27	4.29	4.31	4.34	4.36	4.38	4.40	4.42
-1.	4.29	4.31	4.33	4.36	4.38	4.40	4.42	4.44	4.47
-2.	4.33	4.35	4.38	4.40	4.42	4.44	4.46	4.49	4.51
-3.	4.37	4.40	4.42	4.44	4.46	4.48	4.51	4.53	4.55
-4.	4.42	4.44	4.46	4.48	4.50	4.53	4.55	4.57	4.59
-5.	4.46	4.48	4.50	4.52	4.55	4.57	4.59	4.61	4.63
-6.	4.50	4.52	4.54	4.57	4.59	4.61	4.63	4.65	4.68
-7.	4.54	4.56	4.59	4.61	4.63	4.65	4.67	4.70	4.72
-8.	4.58	4.61	4.63	4.65	4.67	4.69	4.72	4.74	4.76
-9.	4.63	4.65	4.67	4.69	4.72	4.74	4.76	4.78	4.80
-10.	4.67	4.69	4.71	4.74	4.76	4.78	4.80	4.82	4.85
-11.	4.71	4.73	4.76	4.78	4.80	4.82	4.84	4.87	4.89
-12.	4.75	4.78	4.80	4.82	4.84	4.87	4.89	4.91	4.93
-13.	4.80	4.82	4.84	4.86	4.89	4.91	4.93	4.95	4.98
-14.	4.84	4.86	4.89	4.91	4.93	4.95	4.97	5.00	
-15.	4.88	4.91	4.93	4.95	4.97	5.00			
-16.	4.93	4.95	4.97	4.99					
-17.	4.97	4.99							
-18.									
-19.									
-20.									
	12.33	12.34	12.35	12.36	12.37	12.38	12.39	12.40	12.41

Heater Resistance (Ohm) ----->

GO TO NEXT PAGE

12.56. BLADE DE-ICE CONTROLLER ADJUSTMENT - continued

TABLE I. MAIN ROTOR BLADE ADJUSTMENT CHARTS (cont)

Blade Temp. (°C)	Main Rotor Adjustment Resistance (Kiloohm)								
	2.48	2.50	2.52	2.54	2.56	2.58	2.60	2.62	2.64
50.	2.48	2.50	2.52	2.54	2.56	2.58	2.60	2.62	2.64
49.	2.51	2.53	2.55	2.57	2.59	2.61	2.63	2.65	2.67
48.	2.55	2.57	2.59	2.61	2.63	2.65	2.67	2.69	2.71
47.	2.59	2.61	2.63	2.65	2.67	2.69	2.71	2.73	2.75
46.	2.62	2.64	2.66	2.68	2.70	2.72	2.74	2.76	2.78
45.	2.66	2.68	2.70	2.72	2.74	2.76	2.78	2.80	2.82
44.	2.69	2.71	2.73	2.75	2.78	2.80	2.82	2.84	2.86
43.	2.73	2.75	2.77	2.79	2.81	2.83	2.85	2.87	2.89
42.	2.77	2.79	2.81	2.83	2.85	2.87	2.89	2.91	2.93
41.	2.80	2.82	2.84	2.86	2.89	2.91	2.93	2.95	2.97
40.	2.84	2.86	2.88	2.90	2.92	2.94	2.96	2.98	3.00
39.	2.88	2.90	2.92	2.94	2.96	2.98	3.00	3.02	3.04
38.	2.91	2.93	2.96	2.98	3.00	3.02	3.04	3.06	3.08
37.	2.95	2.97	2.99	3.01	3.03	3.05	3.07	3.09	3.12
36.	2.99	3.01	3.03	3.05	3.07	3.09	3.11	3.13	3.15
35.	3.03	3.05	3.07	3.09	3.11	3.13	3.15	3.17	3.19
34.	3.06	3.08	3.10	3.13	3.15	3.17	3.19	3.21	3.23
33.	3.10	3.12	3.14	3.16	3.18	3.20	3.22	3.25	3.27
32.	3.14	3.16	3.18	3.20	3.22	3.24	3.26	3.28	3.30
31.	3.18	3.20	3.22	3.24	3.26	3.28	3.30	3.32	3.34
30.	3.21	3.23	3.26	3.28	3.30	3.32	3.34	3.36	3.38
29.	3.25	3.27	3.29	3.31	3.33	3.36	3.38	3.40	3.42
28.	3.29	3.31	3.33	3.35	3.37	3.39	3.41	3.44	3.46
27.	3.33	3.35	3.37	3.39	3.41	3.43	3.45	3.47	3.49
26.	3.37	3.39	3.41	3.43	3.45	3.47	3.49	3.51	3.53
25.	3.40	3.43	3.45	3.47	3.49	3.51	3.53	3.55	3.57
24.	3.44	3.46	3.49	3.51	3.53	3.55	3.57	3.59	3.61
23.	3.48	3.50	3.52	3.54	3.57	3.59	3.61	3.63	3.65
22.	3.52	3.54	3.56	3.58	3.60	3.63	3.65	3.67	3.69
21.	3.56	3.58	3.60	3.62	3.64	3.66	3.69	3.71	3.73
20.	3.60	3.62	3.64	3.66	3.68	3.70	3.72	3.75	3.77
19.	3.64	3.66	3.68	3.70	3.72	3.74	3.76	3.79	3.81
18.	3.68	3.70	3.72	3.74	3.76	3.78	3.80	3.82	3.85
17.	3.72	3.74	3.76	3.78	3.80	3.82	3.84	3.86	3.89
16.	3.76	3.78	3.80	3.82	3.84	3.86	3.88	3.90	3.93
15.	3.80	3.82	3.84	3.86	3.88	3.90	3.92	3.94	3.97
14.	3.84	3.86	3.88	3.90	3.92	3.94	3.96	3.98	4.00
13.	3.87	3.90	3.92	3.94	3.96	3.98	4.00	4.02	4.05
12.	3.91	3.94	3.96	3.98	4.00	4.02	4.04	4.06	4.09
11.	3.95	3.98	4.00	4.02	4.04	4.06	4.08	4.10	4.13
10.	4.00	4.02	4.04	4.06	4.08	4.10	4.12	4.14	4.17
9.	4.04	4.06	4.08	4.10	4.12	4.14	4.16	4.19	4.21
8.	4.08	4.10	4.12	4.14	4.16	4.18	4.20	4.23	4.25
7.	4.12	4.14	4.16	4.18	4.20	4.22	4.25	4.27	4.29
6.	4.16	4.18	4.20	4.22	4.24	4.26	4.29	4.31	4.33
5.	4.20	4.22	4.24	4.26	4.28	4.31	4.33	4.35	4.37
4.	4.24	4.26	4.28	4.30	4.33	4.35	4.37	4.39	4.41
3.	4.28	4.30	4.32	4.34	4.37	4.39	4.41	4.43	4.45
2.	4.32	4.34	4.36	4.39	4.41	4.43	4.45	4.47	4.49
1.	4.36	4.38	4.41	4.43	4.45	4.47	4.49	4.51	4.54
0.	4.40	4.43	4.45	4.47	4.49	4.51	4.53	4.56	4.58
-1.	4.45	4.47	4.49	4.51	4.53	4.55	4.58	4.60	4.62
-2.	4.49	4.51	4.53	4.55	4.57	4.60	4.62	4.64	4.66
-3.	4.53	4.55	4.57	4.59	4.62	4.64	4.66	4.68	4.70
-4.	4.57	4.59	4.61	4.64	4.66	4.68	4.70	4.72	4.75
-5.	4.61	4.63	4.66	4.68	4.70	4.72	4.74	4.77	4.79
-6.	4.66	4.68	4.70	4.72	4.74	4.76	4.79	4.81	4.83
-7.	4.70	4.72	4.74	4.76	4.79	4.81	4.83	4.85	4.87
-8.	4.74	4.76	4.78	4.81	4.83	4.85	4.87	4.89	4.92
-9.	4.78	4.80	4.83	4.85	4.87	4.89	4.91	4.94	4.96
-10.	4.83	4.85	4.87	4.89	4.91	4.94	4.96	4.98	
-11.	4.87	4.89	4.91	4.93	4.96	4.98			
-12.	4.91	4.93	4.96	4.98	5.00				
-13.	4.95	4.98	5.00						
-14.	5.00								
-15.									
-16.									
-17.									
-18.									
-19.									
-20.									
	12.42	12.43	12.44	12.45	12.46	12.47	12.48	12.49	12.50

Heater Resistance (Ohm) ----->

GO TO NEXT PAGE

12.56. BLADE DE-ICE CONTROLLER ADJUSTMENT - continued

TABLE I. MAIN ROTOR BLADE ADJUSTMENT CHARTS (cont)

Blade Temp. (°C)	Main Rotor Adjustment Resistance (Kiloohm)									
	12.51	12.52	12.53	12.54	12.55	12.56	12.57	12.58	12.59	
50.	2.66	2.68	2.70	2.72	2.74	2.76	2.78	2.80	2.82	2.82
49.	2.69	2.71	2.74	2.76	2.78	2.80	2.82	2.84	2.86	2.86
48.	2.73	2.75	2.77	2.79	2.81	2.83	2.85	2.87	2.89	2.89
47.	2.77	2.79	2.81	2.83	2.85	2.87	2.89	2.91	2.93	2.93
46.	2.80	2.82	2.84	2.86	2.88	2.90	2.93	2.95	2.97	2.97
45.	2.84	2.86	2.88	2.90	2.92	2.94	2.96	2.98	3.00	3.00
44.	2.88	2.90	2.92	2.94	2.96	2.98	3.00	3.02	3.04	3.04
43.	2.91	2.93	2.95	2.97	2.99	3.02	3.04	3.06	3.08	3.08
42.	2.95	2.97	2.99	3.01	3.03	3.05	3.07	3.09	3.11	3.11
41.	2.99	3.01	3.03	3.05	3.07	3.09	3.11	3.13	3.15	3.15
40.	3.02	3.04	3.07	3.09	3.11	3.13	3.15	3.17	3.19	3.19
39.	3.06	3.08	3.10	3.12	3.14	3.16	3.18	3.20	3.23	3.23
38.	3.10	3.12	3.14	3.16	3.18	3.20	3.22	3.24	3.26	3.26
37.	3.14	3.16	3.18	3.20	3.22	3.24	3.26	3.28	3.30	3.30
36.	3.17	3.19	3.21	3.24	3.26	3.28	3.30	3.32	3.34	3.34
35.	3.21	3.23	3.25	3.27	3.29	3.31	3.33	3.36	3.38	3.38
34.	3.25	3.27	3.29	3.31	3.33	3.35	3.37	3.39	3.41	3.41
33.	3.29	3.31	3.33	3.35	3.37	3.39	3.41	3.43	3.45	3.45
32.	3.32	3.35	3.37	3.39	3.41	3.43	3.45	3.47	3.49	3.49
31.	3.36	3.38	3.40	3.42	3.45	3.47	3.49	3.51	3.53	3.53
30.	3.40	3.42	3.44	3.46	3.48	3.50	3.52	3.55	3.57	3.57
29.	3.44	3.46	3.48	3.50	3.52	3.54	3.56	3.58	3.60	3.60
28.	3.48	3.50	3.52	3.54	3.56	3.58	3.60	3.62	3.64	3.64
27.	3.52	3.54	3.56	3.58	3.60	3.62	3.64	3.66	3.68	3.68
26.	3.55	3.58	3.60	3.62	3.64	3.66	3.68	3.70	3.72	3.72
25.	3.59	3.61	3.63	3.66	3.68	3.70	3.72	3.74	3.76	3.76
24.	3.63	3.65	3.67	3.69	3.72	3.74	3.76	3.78	3.80	3.80
23.	3.67	3.69	3.71	3.73	3.75	3.78	3.80	3.82	3.84	3.84
22.	3.71	3.73	3.75	3.77	3.79	3.81	3.84	3.86	3.88	3.88
21.	3.75	3.77	3.79	3.81	3.83	3.85	3.87	3.90	3.92	3.92
20.	3.79	3.81	3.83	3.85	3.87	3.89	3.91	3.94	3.96	3.96
19.	3.83	3.85	3.87	3.89	3.91	3.93	3.95	3.98	4.00	4.00
18.	3.87	3.89	3.91	3.93	3.95	3.97	3.99	4.01	4.04	4.04
17.	3.91	3.93	3.95	3.97	3.99	4.01	4.03	4.05	4.08	4.08
16.	3.95	3.97	3.99	4.01	4.03	4.05	4.07	4.09	4.12	4.12
15.	3.99	4.01	4.03	4.05	4.07	4.09	4.11	4.13	4.16	4.16
14.	4.03	4.05	4.07	4.09	4.11	4.13	4.15	4.17	4.20	4.20
13.	4.07	4.09	4.11	4.13	4.15	4.17	4.19	4.22	4.24	4.24
12.	4.11	4.13	4.15	4.17	4.19	4.21	4.23	4.26	4.28	4.28
11.	4.15	4.17	4.19	4.21	4.23	4.25	4.27	4.30	4.32	4.32
10.	4.19	4.21	4.23	4.25	4.27	4.29	4.32	4.34	4.36	4.36
9.	4.23	4.25	4.27	4.29	4.31	4.33	4.36	4.38	4.40	4.40
8.	4.27	4.29	4.31	4.33	4.35	4.38	4.40	4.42	4.44	4.44
7.	4.31	4.33	4.35	4.37	4.40	4.42	4.44	4.46	4.48	4.48
6.	4.35	4.37	4.39	4.42	4.44	4.46	4.48	4.50	4.52	4.52
5.	4.39	4.41	4.43	4.46	4.48	4.50	4.52	4.54	4.56	4.56
4.	4.43	4.45	4.48	4.50	4.52	4.54	4.56	4.58	4.61	4.61
3.	4.47	4.50	4.52	4.54	4.56	4.58	4.60	4.63	4.65	4.65
2.	4.52	4.54	4.56	4.58	4.60	4.62	4.65	4.67	4.69	4.69
1.	4.56	4.58	4.60	4.62	4.64	4.67	4.69	4.71	4.73	4.73
0.	4.60	4.62	4.64	4.66	4.69	4.71	4.73	4.75	4.77	4.77
-1.	4.64	4.66	4.68	4.71	4.73	4.75	4.77	4.79	4.81	4.81
-2.	4.68	4.70	4.73	4.75	4.77	4.79	4.81	4.84	4.86	4.86
-3.	4.72	4.75	4.77	4.79	4.81	4.83	4.86	4.88	4.90	4.90
-4.	4.77	4.79	4.81	4.83	4.85	4.88	4.90	4.92	4.94	4.94
-5.	4.81	4.83	4.85	4.88	4.90	4.92	4.94	4.96	4.98	4.98
-6.	4.85	4.87	4.90	4.92	4.94	4.96	4.98			
-7.	4.89	4.92	4.94	4.96	4.98					
-8.	4.94	4.96								
-9.	4.98									
-10.										
-11.										
-12.										
-13.										
-14.										
-15.										
-16.										
-17.										
-18.										
-19.										
-20.										
	12.51	12.52	12.53	12.54	12.55	12.56	12.57	12.58	12.59	

Heater Resistance (Ohm) ----->

GO TO NEXT PAGE

12.56. BLADE DE-ICE CONTROLLER ADJUSTMENT - continued

TABLE I. MAIN ROTOR BLADE ADJUSTMENT CHARTS (cont)

Blade Temp. (°C)	Main Rotor Adjustment Resistance (Kiloohm)								
	2.84	2.86	2.88	2.90	2.92	2.94	2.96	2.98	3.00
50.	2.84	2.86	2.88	2.90	2.92	2.94	2.96	2.98	3.00
49.	2.88	2.90	2.92	2.94	2.96	2.98	3.00	3.02	3.04
48.	2.91	2.93	2.95	2.97	2.99	3.01	3.03	3.05	3.07
47.	2.95	2.97	2.99	3.01	3.03	3.05	3.07	3.09	3.11
46.	2.99	3.01	3.03	3.05	3.07	3.09	3.11	3.13	3.15
45.	3.02	3.04	3.06	3.08	3.10	3.12	3.14	3.16	3.19
44.	3.06	3.08	3.10	3.12	3.14	3.16	3.18	3.20	3.22
43.	3.10	3.12	3.14	3.16	3.18	3.20	3.22	3.24	3.26
42.	3.13	3.15	3.17	3.19	3.22	3.24	3.26	3.28	3.30
41.	3.17	3.19	3.21	3.23	3.25	3.27	3.29	3.31	3.33
40.	3.21	3.23	3.25	3.27	3.29	3.31	3.33	3.35	3.37
39.	3.25	3.27	3.29	3.31	3.33	3.35	3.37	3.39	3.41
38.	3.28	3.30	3.32	3.34	3.37	3.39	3.41	3.43	3.45
37.	3.32	3.34	3.36	3.38	3.40	3.42	3.44	3.46	3.48
36.	3.36	3.38	3.40	3.42	3.44	3.46	3.48	3.50	3.52
35.	3.40	3.42	3.44	3.46	3.48	3.50	3.52	3.54	3.56
34.	3.43	3.45	3.48	3.50	3.52	3.54	3.56	3.58	3.60
33.	3.47	3.49	3.51	3.53	3.55	3.58	3.60	3.62	3.64
32.	3.51	3.53	3.55	3.57	3.59	3.61	3.63	3.66	3.68
31.	3.55	3.57	3.59	3.61	3.63	3.65	3.67	3.69	3.71
30.	3.59	3.61	3.63	3.65	3.67	3.69	3.71	3.73	3.75
29.	3.63	3.65	3.67	3.69	3.71	3.73	3.75	3.77	3.79
28.	3.66	3.69	3.71	3.73	3.75	3.77	3.79	3.81	3.83
27.	3.70	3.72	3.74	3.77	3.79	3.81	3.83	3.85	3.87
26.	3.74	3.76	3.78	3.80	3.83	3.85	3.87	3.89	3.91
25.	3.78	3.80	3.82	3.84	3.86	3.89	3.91	3.93	3.95
24.	3.82	3.84	3.86	3.88	3.90	3.92	3.95	3.97	3.99
23.	3.86	3.88	3.90	3.92	3.94	3.96	3.98	4.01	4.03
22.	3.90	3.92	3.94	3.96	3.98	4.00	4.02	4.05	4.07
21.	3.94	3.96	3.98	4.00	4.02	4.04	4.06	4.09	4.11
20.	3.98	4.00	4.02	4.04	4.06	4.08	4.10	4.12	4.15
19.	4.02	4.04	4.06	4.08	4.10	4.12	4.14	4.16	4.19
18.	4.06	4.08	4.10	4.12	4.14	4.16	4.18	4.20	4.23
17.	4.10	4.12	4.14	4.16	4.18	4.20	4.22	4.24	4.27
16.	4.14	4.16	4.18	4.20	4.22	4.24	4.26	4.29	4.31
15.	4.18	4.20	4.22	4.24	4.26	4.28	4.30	4.33	4.35
14.	4.22	4.24	4.26	4.28	4.30	4.32	4.34	4.37	4.39
13.	4.26	4.28	4.30	4.32	4.34	4.36	4.39	4.41	4.43
12.	4.30	4.32	4.34	4.36	4.38	4.40	4.43	4.45	4.47
11.	4.34	4.36	4.38	4.40	4.42	4.45	4.47	4.49	4.51
10.	4.38	4.40	4.42	4.44	4.47	4.49	4.51	4.53	4.55
9.	4.42	4.44	4.46	4.48	4.51	4.53	4.55	4.57	4.59
8.	4.46	4.48	4.50	4.53	4.55	4.57	4.59	4.61	4.63
7.	4.50	4.52	4.55	4.57	4.59	4.61	4.63	4.65	4.67
6.	4.54	4.57	4.59	4.61	4.63	4.65	4.67	4.69	4.72
5.	4.59	4.61	4.63	4.65	4.67	4.69	4.71	4.74	4.76
4.	4.63	4.65	4.67	4.69	4.71	4.73	4.76	4.78	4.80
3.	4.67	4.69	4.71	4.73	4.75	4.78	4.80	4.82	4.84
2.	4.71	4.73	4.75	4.78	4.80	4.82	4.84	4.86	4.88
1.	4.75	4.77	4.80	4.82	4.84	4.86	4.88	4.90	4.93
0.	4.79	4.82	4.84	4.86	4.88	4.90	4.92	4.95	4.97
-1.	4.84	4.86	4.88	4.90	4.92	4.95	4.97		
-2.	4.88	4.90	4.92	4.94	4.97				
-3.	4.92	4.94	4.96						
-4.	4.96	4.99							
-5.									
-6.									
-7.									
-8.									
-9.									
-10.									
-11.									
-12.									
-13.									
-14.									
-15.									
-16.									
-17.									
-18.									
-19.									
-20.									
	12.60	12.61	12.62	12.63	12.64	12.65	12.66	12.67	12.68

Heater Resistance (Ohm) ----->

GO TO NEXT PAGE

12.56. BLADE DE-ICE CONTROLLER ADJUSTMENT - continued

TABLE I. MAIN ROTOR BLADE ADJUSTMENT CHARTS (cont)

Blade Temp. (°C)	Main Rotor Adjustment Resistance (Kiloohm)								
	12.69	12.70	12.71	12.72	12.73	12.74	12.75	12.76	12.77
50.	3.02	3.04	3.06	3.08	3.10	3.12	3.14	3.16	3.18
49.	3.06	3.08	3.10	3.12	3.14	3.16	3.18	3.20	3.22
48.	3.09	3.11	3.13	3.16	3.18	3.20	3.22	3.24	3.26
47.	3.13	3.15	3.17	3.19	3.21	3.23	3.25	3.27	3.29
46.	3.17	3.19	3.21	3.23	3.25	3.27	3.29	3.31	3.33
45.	3.21	3.23	3.25	3.27	3.29	3.31	3.33	3.35	3.37
44.	3.24	3.26	3.28	3.30	3.32	3.34	3.36	3.38	3.40
43.	3.28	3.30	3.32	3.34	3.36	3.38	3.40	3.42	3.44
42.	3.32	3.34	3.36	3.38	3.40	3.42	3.44	3.46	3.48
41.	3.35	3.37	3.40	3.42	3.44	3.46	3.48	3.50	3.52
40.	3.39	3.41	3.43	3.45	3.47	3.49	3.51	3.54	3.56
39.	3.43	3.45	3.47	3.49	3.51	3.53	3.55	3.57	3.59
38.	3.47	3.49	3.51	3.53	3.55	3.57	3.59	3.61	3.63
37.	3.51	3.53	3.55	3.57	3.59	3.61	3.63	3.65	3.67
36.	3.54	3.56	3.58	3.61	3.63	3.65	3.67	3.69	3.71
35.	3.58	3.60	3.62	3.64	3.66	3.68	3.71	3.73	3.75
34.	3.62	3.64	3.66	3.68	3.70	3.72	3.74	3.76	3.78
33.	3.66	3.68	3.70	3.72	3.74	3.76	3.78	3.80	3.82
32.	3.70	3.72	3.74	3.76	3.78	3.80	3.82	3.84	3.86
31.	3.74	3.76	3.78	3.80	3.82	3.84	3.86	3.88	3.90
30.	3.77	3.79	3.82	3.84	3.86	3.88	3.90	3.92	3.94
29.	3.81	3.83	3.85	3.87	3.90	3.92	3.94	3.96	3.98
28.	3.85	3.87	3.89	3.91	3.93	3.96	3.98	4.00	4.02
27.	3.89	3.91	3.93	3.95	3.97	3.99	4.02	4.04	4.06
26.	3.93	3.95	3.97	3.99	4.01	4.03	4.05	4.08	4.10
25.	3.97	3.99	4.01	4.03	4.05	4.07	4.09	4.12	4.14
24.	4.01	4.03	4.05	4.07	4.09	4.11	4.13	4.15	4.18
23.	4.05	4.07	4.09	4.11	4.13	4.15	4.17	4.19	4.22
22.	4.09	4.11	4.13	4.15	4.17	4.19	4.21	4.23	4.26
21.	4.13	4.15	4.17	4.19	4.21	4.23	4.25	4.27	4.30
20.	4.17	4.19	4.21	4.23	4.25	4.27	4.29	4.31	4.34
19.	4.21	4.23	4.25	4.27	4.29	4.31	4.33	4.35	4.38
18.	4.25	4.27	4.29	4.31	4.33	4.35	4.37	4.39	4.42
17.	4.29	4.31	4.33	4.35	4.37	4.39	4.41	4.44	4.46
16.	4.33	4.35	4.37	4.39	4.41	4.43	4.45	4.48	4.50
15.	4.37	4.39	4.41	4.43	4.45	4.47	4.50	4.52	4.54
14.	4.41	4.43	4.45	4.47	4.49	4.51	4.54	4.56	4.58
13.	4.45	4.47	4.49	4.51	4.53	4.56	4.58	4.60	4.62
12.	4.49	4.51	4.53	4.55	4.58	4.60	4.62	4.64	4.66
11.	4.53	4.55	4.57	4.59	4.62	4.64	4.66	4.68	4.70
10.	4.57	4.59	4.61	4.64	4.66	4.68	4.70	4.72	4.74
9.	4.61	4.63	4.66	4.68	4.70	4.72	4.74	4.76	4.78
8.	4.65	4.68	4.70	4.72	4.74	4.76	4.78	4.80	4.83
7.	4.70	4.72	4.74	4.76	4.78	4.80	4.82	4.85	4.87
6.	4.74	4.76	4.78	4.80	4.82	4.84	4.87	4.89	4.91
5.	4.78	4.80	4.82	4.84	4.87	4.89	4.91	4.93	4.95
4.	4.82	4.84	4.86	4.89	4.91	4.93	4.95	4.97	4.99
3.	4.86	4.88	4.91	4.93	4.95	4.97			
2.	4.90	4.93	4.95	4.97	4.99				
1.	4.95	4.97	4.99						
0.	4.99								
-1.									
-2.									
-3.									
-4.									
-5.									
-6.									
-7.									
-8.									
-9.									
-10.									
-11.									
-12.									
-13.									
-14.									
-15.									
-16.									
-17.									
-18.									
-19.									
-20.									

GO TO NEXT PAGE



12.56. BLADE DE-ICE CONTROLLER ADJUSTMENT - continued

TABLE I. MAIN ROTOR BLADE ADJUSTMENT CHARTS (cont)

Blade Temp. (°C)	Main Rotor Adjustment Resistance (Kiloohm)									
	3.20	3.22	3.24	3.26	3.28	3.30	3.32	3.34	3.36	3.38
50.	3.20	3.22	3.24	3.26	3.28	3.30	3.32	3.34	3.36	3.38
49.	3.24	3.26	3.28	3.30	3.32	3.34	3.36	3.38	3.40	3.42
48.	3.28	3.30	3.32	3.34	3.36	3.38	3.41	3.43	3.46	3.48
47.	3.31	3.33	3.35	3.37	3.39	3.41	3.43	3.45	3.47	3.49
46.	3.35	3.37	3.39	3.41	3.43	3.45	3.47	3.49	3.51	3.53
45.	3.39	3.41	3.43	3.45	3.47	3.49	3.51	3.53	3.55	3.57
44.	3.43	3.45	3.47	3.49	3.51	3.53	3.55	3.58	3.61	3.63
43.	3.46	3.48	3.50	3.52	3.54	3.56	3.58	3.60	3.62	3.64
42.	3.50	3.52	3.54	3.56	3.58	3.60	3.62	3.64	3.66	3.68
41.	3.54	3.56	3.58	3.60	3.62	3.64	3.66	3.68	3.70	3.72
40.	3.58	3.60	3.62	3.64	3.66	3.68	3.70	3.72	3.74	3.76
39.	3.61	3.63	3.65	3.68	3.70	3.72	3.74	3.76	3.78	3.80
38.	3.65	3.67	3.69	3.71	3.73	3.75	3.77	3.79	3.81	3.83
37.	3.69	3.71	3.73	3.75	3.77	3.79	3.81	3.83	3.85	3.87
36.	3.73	3.75	3.77	3.79	3.81	3.83	3.85	3.87	3.89	3.91
35.	3.77	3.79	3.81	3.83	3.85	3.87	3.89	3.91	3.93	3.95
34.	3.81	3.83	3.85	3.87	3.89	3.91	3.93	3.95	3.97	4.01
33.	3.84	3.86	3.89	3.91	3.93	3.95	3.97	4.01	4.03	4.05
32.	3.88	3.90	3.92	3.94	3.97	3.99	4.01	4.03	4.07	4.09
31.	3.92	3.94	3.96	3.98	4.00	4.02	4.05	4.07	4.11	4.13
30.	3.96	3.98	4.00	4.02	4.04	4.06	4.08	4.11	4.14	4.17
29.	4.00	4.02	4.04	4.06	4.08	4.10	4.12	4.14	4.18	4.21
28.	4.04	4.06	4.08	4.10	4.12	4.14	4.16	4.18	4.22	4.24
27.	4.08	4.10	4.12	4.14	4.16	4.18	4.20	4.22	4.26	4.28
26.	4.12	4.14	4.16	4.18	4.20	4.22	4.24	4.26	4.30	4.32
25.	4.16	4.18	4.20	4.22	4.24	4.26	4.28	4.30	4.32	4.36
24.	4.20	4.22	4.24	4.26	4.28	4.30	4.32	4.34	4.38	4.40
23.	4.24	4.26	4.28	4.30	4.32	4.34	4.36	4.40	4.42	4.44
22.	4.28	4.30	4.32	4.34	4.36	4.38	4.40	4.42	4.46	4.48
21.	4.32	4.34	4.36	4.38	4.40	4.42	4.44	4.48	4.50	4.52
20.	4.36	4.38	4.40	4.42	4.44	4.46	4.48	4.50	4.54	4.57
19.	4.40	4.42	4.44	4.46	4.48	4.50	4.52	4.54	4.58	4.61
18.	4.44	4.46	4.48	4.50	4.52	4.54	4.56	4.60	4.63	4.65
17.	4.48	4.50	4.52	4.54	4.56	4.58	4.60	4.62	4.65	4.69
16.	4.52	4.54	4.56	4.58	4.60	4.62	4.64	4.66	4.69	4.73
15.	4.56	4.58	4.60	4.62	4.64	4.66	4.68	4.71	4.73	4.77
14.	4.60	4.62	4.64	4.66	4.68	4.70	4.72	4.75	4.77	4.81
13.	4.64	4.66	4.68	4.70	4.72	4.74	4.76	4.79	4.81	4.85
12.	4.68	4.70	4.72	4.74	4.76	4.78	4.80	4.83	4.85	4.89
11.	4.72	4.74	4.76	4.78	4.80	4.82	4.84	4.87	4.89	4.94
10.	4.76	4.78	4.80	4.82	4.84	4.86	4.88	4.91	4.93	4.98
9.	4.81	4.83	4.85	4.87	4.89	4.91	4.93	4.95	4.98	
8.	4.85	4.87	4.89	4.91	4.93	4.95	4.98			
7.	4.89	4.91	4.93	4.95	4.97	5.00				
6.	4.93	4.95	4.97	5.00						
5.	4.97									
4.										
3.										
2.										
1.										
0.										
-1.										
-2.										
-3.										
-4.										
-5.										
-6.										
-7.										
-8.										
-9.										
-10.										
-11.										
-12.										
-13.										
-14.										
-15.										
-16.										
-17.										
-18.										
-19.										
-20.										
	12.78	12.79	12.80	12.81	12.82	12.83	12.84	12.85	12.86	
	Heater Resistance (Ohm) ----->									

GO TO NEXT PAGE

12.56. BLADE DE-ICE CONTROLLER ADJUSTMENT - continued

TABLE I. MAIN ROTOR BLADE ADJUSTMENT CHARTS (cont)

Blade Temp. (°C)	Main Rotor Adjustment Resistance (Kiloohm)								
50.	3.38	3.40	3.42	3.44	3.46	3.48	3.50	3.52	3.54
49.	3.42	3.44	3.46	3.48	3.50	3.52	3.54	3.56	3.58
48.	3.46	3.49	3.50	3.52	3.54	3.56	3.58	3.60	3.62
47.	3.50	3.52	3.54	3.56	3.58	3.60	3.62	3.64	3.66
46.	3.53	3.55	3.57	3.59	3.61	3.63	3.65	3.67	3.70
45.	3.57	3.59	3.61	3.63	3.65	3.67	3.69	3.71	3.73
44.	3.61	3.63	3.65	3.67	3.69	3.71	3.73	3.75	3.77
43.	3.65	3.67	3.69	3.71	3.73	3.75	3.77	3.79	3.81
42.	3.68	3.70	3.72	3.74	3.77	3.79	3.81	3.83	3.85
41.	3.72	3.74	3.76	3.78	3.80	3.82	3.84	3.86	3.89
40.	3.76	3.78	3.80	3.82	3.84	3.86	3.88	3.90	3.92
39.	3.80	3.82	3.84	3.86	3.88	3.90	3.92	3.94	3.96
38.	3.84	3.86	3.88	3.90	3.92	3.94	3.96	3.98	4.00
37.	3.87	3.90	3.92	3.94	3.96	3.98	4.00	4.02	4.04
36.	3.91	3.93	3.95	3.98	4.00	4.02	4.04	4.06	4.08
35.	3.95	3.97	3.99	4.01	4.03	4.05	4.08	4.10	4.12
34.	3.99	4.01	4.03	4.05	4.07	4.09	4.11	4.14	4.16
33.	4.03	4.05	4.07	4.09	4.11	4.13	4.15	4.17	4.19
32.	4.07	4.09	4.11	4.13	4.15	4.17	4.19	4.21	4.23
31.	4.11	4.13	4.15	4.17	4.19	4.21	4.23	4.25	4.27
30.	4.15	4.17	4.19	4.21	4.23	4.25	4.27	4.29	4.31
29.	4.19	4.21	4.23	4.25	4.27	4.29	4.31	4.33	4.35
28.	4.23	4.25	4.27	4.29	4.31	4.33	4.35	4.37	4.39
27.	4.27	4.29	4.31	4.33	4.35	4.37	4.39	4.41	4.43
26.	4.31	4.33	4.35	4.37	4.39	4.41	4.43	4.45	4.47
25.	4.34	4.37	4.39	4.41	4.43	4.45	4.47	4.49	4.51
24.	4.38	4.41	4.43	4.45	4.47	4.49	4.51	4.53	4.55
23.	4.42	4.45	4.47	4.49	4.51	4.53	4.55	4.57	4.59
22.	4.47	4.49	4.51	4.53	4.55	4.57	4.59	4.61	4.63
21.	4.51	4.53	4.55	4.57	4.59	4.61	4.63	4.65	4.67
20.	4.55	4.57	4.59	4.61	4.63	4.65	4.67	4.69	4.71
19.	4.59	4.61	4.63	4.65	4.67	4.69	4.71	4.73	4.75
18.	4.63	4.65	4.67	4.69	4.71	4.73	4.75	4.77	4.80
17.	4.67	4.69	4.71	4.73	4.75	4.77	4.79	4.82	4.84
16.	4.71	4.73	4.75	4.77	4.79	4.81	4.84	4.86	4.88
15.	4.75	4.77	4.79	4.81	4.83	4.86	4.88	4.90	4.92
14.	4.79	4.81	4.83	4.85	4.88	4.90	4.92	4.94	4.96
13.	4.83	4.85	4.87	4.90	4.92	4.94	4.96	4.98	
12.	4.87	4.89	4.92	4.94	4.96	4.98			
11.	4.91	4.94	4.96	4.98					
10.	4.96	4.98	5.00						
9.	5.00								
8.									
7.									
6.									
5.									
4.									
3.									
2.									
1.									
0.									
-1.									
-2.									
-3.									
-4.									
-5.									
-6.									
-7.									
-8.									
-9.									
-10.									
-11.									
-12.									
-13.									
-14.									
-15.									
-16.									
-17.									
-18.									
-19.									
-20.									
	12.87	12.88	12.89	12.90	12.91	12.92	12.93	12.94	12.95

Heater Resistance (Ohm) ----->

GO TO NEXT PAGE

12.56. BLADE DE-ICE CONTROLLER ADJUSTMENT - continued

TABLE I. MAIN ROTOR BLADE ADJUSTMENT CHARTS (cont)

Blade Temp. (°C)	Main Rotor Adjustment Resistance (Kiloohm)									
	3.57	3.59	3.61	3.63	3.65	3.67	3.69	3.71	3.73	
50.	3.57	3.59	3.61	3.63	3.65	3.67	3.69	3.71	3.73	
49.	3.60	3.62	3.64	3.66	3.68	3.70	3.72	3.74	3.76	
48.	3.64	3.66	3.68	3.70	3.72	3.74	3.76	3.78	3.80	
47.	3.68	3.70	3.72	3.74	3.76	3.78	3.80	3.82	3.84	
46.	3.72	3.74	3.76	3.78	3.80	3.82	3.84	3.86	3.88	
45.	3.75	3.77	3.79	3.81	3.83	3.85	3.87	3.90	3.92	
44.	3.79	3.81	3.83	3.85	3.87	3.89	3.91	3.93	3.95	
43.	3.83	3.85	3.87	3.89	3.91	3.93	3.95	3.97	3.99	
42.	3.87	3.89	3.91	3.93	3.95	3.97	3.99	4.01	4.03	
41.	3.91	3.93	3.95	3.97	3.99	4.01	4.03	4.05	4.07	
40.	3.94	3.96	3.98	4.01	4.03	4.05	4.07	4.09	4.11	
39.	3.98	4.00	4.02	4.04	4.06	4.08	4.11	4.13	4.15	
38.	4.02	4.04	4.06	4.08	4.10	4.12	4.14	4.16	4.18	
37.	4.06	4.08	4.10	4.12	4.14	4.16	4.18	4.20	4.22	
36.	4.10	4.12	4.14	4.16	4.18	4.20	4.22	4.24	4.26	
35.	4.14	4.16	4.18	4.20	4.22	4.24	4.26	4.28	4.30	
34.	4.18	4.20	4.22	4.24	4.26	4.28	4.30	4.32	4.34	
33.	4.22	4.24	4.26	4.28	4.30	4.32	4.34	4.36	4.38	
32.	4.25	4.28	4.30	4.32	4.34	4.36	4.38	4.40	4.42	
31.	4.29	4.31	4.34	4.36	4.38	4.40	4.42	4.44	4.46	
30.	4.33	4.35	4.38	4.40	4.42	4.44	4.46	4.48	4.50	
29.	4.37	4.39	4.41	4.44	4.46	4.48	4.50	4.52	4.54	
28.	4.41	4.43	4.45	4.48	4.50	4.52	4.54	4.56	4.58	
27.	4.45	4.47	4.49	4.52	4.54	4.56	4.58	4.60	4.62	
26.	4.49	4.51	4.53	4.56	4.58	4.60	4.62	4.64	4.66	
25.	4.53	4.55	4.57	4.60	4.62	4.64	4.66	4.68	4.70	
24.	4.57	4.59	4.61	4.64	4.66	4.68	4.70	4.72	4.74	
23.	4.61	4.63	4.66	4.68	4.70	4.72	4.74	4.76	4.78	
22.	4.65	4.67	4.70	4.72	4.74	4.76	4.78	4.80	4.82	
21.	4.69	4.72	4.74	4.76	4.78	4.80	4.82	4.84	4.86	
20.	4.74	4.76	4.78	4.80	4.82	4.84	4.86	4.88	4.90	
19.	4.78	4.80	4.82	4.84	4.86	4.88	4.90	4.92	4.94	
18.	4.82	4.84	4.86	4.88	4.90	4.92	4.94	4.96	4.98	
17.	4.86	4.88	4.90	4.92	4.94	4.96	4.98			
16.	4.90	4.92	4.94	4.96						
15.	4.94	4.96	4.98							
14.	4.98									
13.										
12.										
11.										
10.										
9.										
8.										
7.										
6.										
5.										
4.										
3.										
2.										
1.										
0.										
-1.										
-2.										
-3.										
-4.										
-5.										
-6.										
-7.										
-8.										
-9.										
-10.										
-11.										
-12.										
-13.										
-14.										
-15.										
-16.										
-17.										
-18.										
-19.										
-20.										
	12.96	12.97	12.98	12.99	13.00	13.01	13.02	13.03	13.04	
	Heater Resistance (Ohm) ----->									

GO TO NEXT PAGE

12.56. BLADE DE-ICE CONTROLLER ADJUSTMENT - continued

TABLE I. MAIN ROTOR BLADE ADJUSTMENT CHARTS (cont)

Blade Temp. (°C)	Main Rotor Adjustment Resistance (Kiloohm)								
	3.75	3.77	3.79	3.81	3.83	3.85	3.87	3.89	3.91
50.	3.75	3.77	3.79	3.81	3.83	3.85	3.87	3.89	3.91
49.	3.78	3.80	3.82	3.84	3.86	3.88	3.91	3.93	3.95
48.	3.82	3.84	3.86	3.88	3.90	3.92	3.94	3.96	3.98
47.	3.86	3.88	3.90	3.92	3.94	3.96	3.98	4.00	4.02
46.	3.90	3.92	3.94	3.96	3.98	4.00	4.02	4.04	4.06
45.	3.94	3.96	3.98	4.00	4.02	4.04	4.06	4.08	4.10
44.	3.97	3.99	4.01	4.03	4.06	4.08	4.10	4.12	4.14
43.	4.01	4.03	4.05	4.07	4.09	4.11	4.13	4.15	4.17
42.	4.05	4.07	4.09	4.11	4.13	4.15	4.17	4.19	4.21
41.	4.09	4.11	4.13	4.15	4.17	4.19	4.21	4.23	4.25
40.	4.13	4.15	4.17	4.19	4.21	4.23	4.25	4.27	4.29
39.	4.17	4.19	4.21	4.23	4.25	4.27	4.29	4.31	4.33
38.	4.21	4.23	4.25	4.27	4.29	4.31	4.33	4.35	4.37
37.	4.24	4.26	4.29	4.31	4.33	4.35	4.37	4.39	4.41
36.	4.28	4.30	4.32	4.34	4.37	4.39	4.41	4.43	4.45
35.	4.32	4.34	4.36	4.38	4.40	4.43	4.45	4.47	4.49
34.	4.36	4.38	4.40	4.42	4.44	4.46	4.49	4.51	4.53
33.	4.40	4.42	4.44	4.46	4.48	4.50	4.53	4.55	4.57
32.	4.44	4.46	4.48	4.50	4.52	4.54	4.56	4.59	4.61
31.	4.48	4.50	4.52	4.54	4.56	4.58	4.60	4.63	4.65
30.	4.52	4.54	4.56	4.58	4.60	4.62	4.64	4.67	4.69
29.	4.56	4.58	4.60	4.62	4.64	4.66	4.68	4.71	4.73
28.	4.60	4.62	4.64	4.66	4.68	4.70	4.72	4.75	4.77
27.	4.64	4.66	4.68	4.70	4.72	4.74	4.77	4.79	4.81
26.	4.68	4.70	4.72	4.74	4.76	4.78	4.81	4.83	4.85
25.	4.72	4.74	4.76	4.78	4.80	4.83	4.85	4.87	4.89
24.	4.76	4.78	4.80	4.82	4.85	4.87	4.89	4.91	4.93
23.	4.80	4.82	4.84	4.86	4.89	4.91	4.93	4.95	4.97
22.	4.84	4.86	4.88	4.91	4.93	4.95	4.97		
21.	4.88	4.90	4.93	4.95	4.97				
20.	4.92	4.95	4.97						
19.	4.97	4.99							
18.									
17.									
16.									
15.									
14.									
13.									
12.									
11.									
10.									
9.									
8.									
7.									
6.									
5.									
4.									
3.									
2.									
1.									
0.									
-1.									
-2.									
-3.									
-4.									
-5.									
-6.									
-7.									
-8.									
-9.									
-10.									
-11.									
-12.									
-13.									
-14.									
-15.									
-16.									
-17.									
-18.									
-19.									
-20.									
	13.05	13.06	13.07	13.08	13.09	13.10	13.11	13.12	13.13

Heater Resistance (Ohm) ----->

GO TO NEXT PAGE

12.56. BLADE DE-ICE CONTROLLER ADJUSTMENT - continued

TABLE I. MAIN ROTOR BLADE ADJUSTMENT CHARTS (cont)

Blade Temp. (°C)	Main Rotor Adjustment Resistance (Kiloohm)								
	3.93	3.95	3.97	3.99	4.01	4.03	4.05	4.07	4.09
50.	3.93	3.95	3.97	3.99	4.01	4.03	4.05	4.07	4.09
49.	3.97	3.99	4.01	4.03	4.05	4.07	4.09	4.11	4.13
48.	4.00	4.02	4.04	4.06	4.08	4.10	4.12	4.14	4.17
47.	4.04	4.06	4.08	4.10	4.12	4.14	4.16	4.18	4.20
46.	4.08	4.10	4.12	4.14	4.16	4.18	4.20	4.22	4.24
45.	4.12	4.14	4.16	4.18	4.20	4.22	4.24	4.26	4.28
44.	4.16	4.18	4.20	4.22	4.24	4.26	4.28	4.30	4.32
43.	4.20	4.22	4.24	4.26	4.28	4.30	4.32	4.34	4.36
42.	4.23	4.25	4.27	4.30	4.32	4.34	4.36	4.38	4.40
41.	4.27	4.29	4.31	4.33	4.35	4.37	4.40	4.42	4.44
40.	4.31	4.33	4.35	4.37	4.39	4.41	4.43	4.45	4.48
39.	4.35	4.37	4.39	4.41	4.43	4.45	4.47	4.49	4.51
38.	4.39	4.41	4.43	4.45	4.47	4.49	5.51	4.53	4.55
37.	4.43	4.45	4.47	4.49	4.51	4.53	4.55	4.57	4.59
36.	4.47	4.49	4.51	4.53	4.55	4.57	4.59	4.61	4.63
35.	4.51	4.53	4.55	4.57	4.59	4.61	4.63	4.65	4.67
34.	4.55	4.57	4.59	4.61	4.63	4.65	4.67	4.69	4.71
33.	4.59	4.61	4.63	4.65	4.67	4.69	4.71	4.73	4.75
32.	4.63	4.65	4.67	4.69	4.71	4.73	4.75	4.77	4.79
31.	4.67	4.69	4.71	4.73	4.75	4.77	4.79	4.81	4.83
30.	4.71	4.73	4.75	4.77	4.79	4.81	4.83	4.85	4.87
29.	4.75	4.77	4.79	4.81	4.83	4.85	4.87	4.89	4.91
28.	4.79	4.81	4.83	4.85	4.87	4.89	4.91	4.93	4.95
27.	4.83	4.85	4.87	4.89	4.91	4.93	4.95	4.97	4.99
26.	4.87	4.89	4.91	4.93	4.95	4.97	4.99		
25.	4.91	4.93	4.95	4.97	4.99				
24.	4.95	4.97	4.99						
23.	4.99								
22.									
21.									
20.									
19.									
18.									
17.									
16.									
15.									
14.									
13.									
12.									
11.									
10.									
9.									
8.									
7.									
6.									
5.									
4.									
3.									
2.									
1.									
0.									
-1.									
-2.									
-3.									
-4.									
-5.									
-6.									
-7.									
-8.									
-9.									
-10.									
-11.									
-12.									
-13.									
-14.									
-15.									
-16.									
-17.									
-18.									
-19.									
-20.									
	13.14	13.15	13.16	13.17	13.18	13.19	13.20	13.21	13.22
	Heater Resistance (Ohm) ----->								

GO TO NEXT PAGE

12.56. BLADE DE-ICE CONTROLLER ADJUSTMENT - continued

TABLE I. MAIN ROTOR BLADE ADJUSTMENT CHARTS (cont)

Blade Temp. (°C)	Main Rotor Adjustment Resistance (Kiloohm)									
	4.11	4.13	4.15	4.17	4.19	4.21	4.23	4.25	4.27	4.29
50.	4.11	4.13	4.15	4.17	4.19	4.21	4.23	4.25	4.27	4.29
49.	4.15	4.17	4.19	4.21	4.23	4.25	4.27	4.29	4.31	4.33
48.	4.19	4.21	4.23	4.25	4.27	4.29	4.31	4.33	4.35	4.37
47.	4.22	4.24	4.26	4.28	4.30	4.32	4.34	4.36	4.38	4.40
46.	4.26	4.28	4.30	4.32	4.34	4.36	4.38	4.40	4.42	4.44
45.	4.30	4.32	4.34	4.36	4.38	4.40	4.42	4.44	4.46	4.48
44.	4.34	4.36	4.38	4.40	4.42	4.44	4.46	4.48	4.50	4.52
43.	4.38	4.40	4.42	4.44	4.46	4.48	4.50	4.52	4.54	4.56
42.	4.42	4.44	4.46	4.48	4.50	4.52	4.54	4.56	4.58	4.60
41.	4.46	4.48	4.50	4.52	4.54	4.56	4.58	4.60	4.62	4.64
40.	4.50	4.52	4.54	4.56	4.58	4.60	4.62	4.64	4.66	4.68
39.	4.53	4.56	4.58	4.60	4.62	4.64	4.66	4.68	4.70	4.72
38.	4.57	4.59	4.62	4.64	4.66	4.68	4.70	4.72	4.74	4.76
37.	4.61	4.63	4.65	4.68	4.70	4.72	4.74	4.76	4.78	4.80
36.	4.65	4.67	4.69	4.71	4.74	4.76	4.78	4.80	4.82	4.84
35.	4.69	4.71	4.73	4.75	4.78	4.80	4.82	4.84	4.86	4.88
34.	4.73	4.75	4.77	4.79	4.82	4.84	4.86	4.88	4.90	4.92
33.	4.77	4.79	4.81	4.83	4.86	4.88	4.90	4.92	4.94	4.96
32.	4.81	4.83	4.85	4.87	4.90	4.92	4.94	4.96	4.98	5.00
31.	4.85	4.87	4.89	4.92	4.94	4.96	4.98	5.00		
30.	4.89	4.91	4.93	4.96	4.98	5.00				
29.	4.93	4.95	4.98	5.00						
28.	4.97	5.00								
27.										
26.										
25.										
24.										
23.										
22.										
21.										
20.										
19.										
18.										
17.										
16.										
15.										
14.										
13.										
12.										
11.										
10.										
9.										
8.										
7.										
6.										
5.										
4.										
3.										
2.										
1.										
0.										
-1.										
-2.										
-3.										
-4.										
-5.										
-6.										
-7.										
-8.										
-9.										
-10.										
-11.										
-12.										
-13.										
-14.										
-15.										
-16.										
-17.										
-18.										
-19.										
-20.										
	13.23	13.24	13.25	13.26	13.27	13.28	13.29	13.30	13.31	

Heater Resistance (Ohm) ----->

GO TO NEXT PAGE

12.56. BLADE DE-ICE CONTROLLER ADJUSTMENT - continued

TABLE I. MAIN ROTOR BLADE ADJUSTMENT CHARTS (cont)

Blade Temp. (°C)	Main Rotor Adjustment Resistance (Kiloohm)								
	4.29	4.31	4.33	4.35	4.37	4.39	4.41	4.43	4.45
50.	4.29	4.31	4.33	4.35	4.37	4.39	4.41	4.43	4.45
49.	4.33	4.35	4.37	4.39	4.41	4.43	4.45	4.47	4.49
48.	4.37	4.39	4.41	4.43	4.45	4.47	4.49	4.51	4.53
47.	4.41	4.43	4.45	4.47	4.49	4.51	4.53	4.55	4.57
46.	4.44	4.46	4.49	4.51	4.53	4.55	4.57	4.59	4.61
45.	4.48	4.50	4.52	4.54	4.56	4.58	4.61	4.63	4.65
44.	4.52	4.54	4.56	4.58	4.60	4.62	4.64	4.66	4.68
43.	4.56	4.58	4.60	4.62	4.64	4.66	4.68	4.70	4.72
42.	4.60	4.62	4.64	4.66	4.68	4.70	4.72	4.74	4.76
41.	4.64	4.66	4.68	4.70	4.72	4.74	4.76	4.78	4.80
40.	4.68	4.70	4.72	4.74	4.76	4.78	4.80	4.82	4.84
39.	4.72	4.74	4.76	4.78	4.80	4.82	4.84	4.86	4.88
38.	4.76	4.78	4.80	4.82	4.84	4.86	4.88	4.90	4.92
37.	4.80	4.82	4.84	4.86	4.88	4.90	4.92	4.94	4.96
36.	4.84	4.86	4.88	4.90	4.92	4.94	4.96	4.98	
35.	4.88	4.90	4.92	4.94	4.96	4.98			
34.	4.92	4.94	4.96	4.98					
33.	4.96	4.98	5.00						
32.	5.00								
31.									
30.									
29.									
28.									
27.									
26.									
25.									
24.									
23.									
22.									
21.									
20.									
19.									
18.									
17.									
16.									
15.									
14.									
13.									
12.									
11.									
10.									
9.									
8.									
7.									
6.									
5.									
4.									
3.									
2.									
1.									
0.									
-1.									
-2.									
-3.									
-4.									
-5.									
-6.									
-7.									
-8.									
-9.									
-10.									
-11.									
-12.									
-13.									
-14.									
-15.									
-16.									
-17.									
-18.									
-19.									
-20.									
	13.32	13.33	13.34	13.35	13.36	13.37	13.38	13.39	13.40

Heater Resistance (Ohm) ----->

GO TO NEXT PAGE

12.56. BLADE DE-ICE CONTROLLER ADJUSTMENT - continued

TABLE I. MAIN ROTOR BLADE ADJUSTMENT CHARTS (cont)

Blade Temp. (°C)	Main Rotor Adjustment Resistance (Kiloohm)								
	4.47	4.49	4.51	4.53	4.55	4.57	4.59	4.61	4.63
50.	4.47	4.49	4.51	4.53	4.55	4.57	4.59	4.61	4.63
49.	4.51	4.53	4.55	4.57	4.59	4.61	4.63	4.65	4.67
48.	4.55	4.57	4.59	4.61	4.63	4.65	4.67	4.69	4.71
47.	4.59	4.61	4.63	4.65	4.67	4.69	4.71	4.73	4.75
46.	4.63	4.65	4.67	4.69	4.71	4.73	4.75	4.77	4.79
45.	4.67	4.69	4.71	4.73	4.75	4.77	4.79	4.81	4.83
44.	4.71	4.73	4.75	4.77	4.79	4.81	4.83	4.85	4.87
43.	4.74	4.76	4.79	4.81	4.83	4.85	4.87	4.89	4.91
42.	4.78	4.80	4.82	4.85	4.87	4.89	4.91	4.93	4.95
41.	4.82	4.84	4.86	4.88	4.91	4.93	4.95	4.97	4.99
40.	4.86	4.88	4.90	4.92	4.95	4.97	4.99		
39.	4.90	4.92	4.94	4.96	4.98				
38.	4.94	4.96	4.98						
37.	4.98								
36.									
35.									
34.									
33.									
32.									
31.									
30.									
29.									
28.									
27.									
26.									
25.									
24.									
23.									
22.									
21.									
20.									
19.									
18.									
17.									
16.									
15.									
14.									
13.									
12.									
11.									
10.									
9.									
8.									
7.									
6.									
5.									
4.									
3.									
2.									
1.									
0.									
-1.									
-2.									
-3.									
-4.									
-5.									
-6.									
-7.									
-8.									
-9.									
-10.									
-11.									
-12.									
-13.									
-14.									
-15.									
-16.									
-17.									
-18.									
-19.									
-20.									
	13.41	13.42	13.43	13.44	13.45	13.46	13.47	13.48	13.49

Heater Resistance (Ohm) ----->

GO TO NEXT PAGE



12.56. BLADE DE-ICE CONTROLLER ADJUSTMENT - continued

TABLE I. MAIN ROTOR BLADE ADJUSTMENT CHARTS (cont)

Blade Temp. (°C)	Main Rotor Adjustment Resistance (Kiloohm)								
	4.65	4.67	4.69	4.71	4.73	4.75	4.77	4.79	4.81
50.	4.65	4.67	4.69	4.71	4.73	4.75	4.77	4.79	4.81
49.	4.69	4.71	4.73	4.75	4.77	4.79	4.81	4.83	4.85
48.	4.73	4.75	4.77	4.79	4.81	4.83	4.85	4.87	4.89
47.	4.77	4.79	4.81	4.83	4.85	4.87	4.89	4.91	4.93
46.	4.81	4.83	4.85	4.87	4.89	4.91	4.93	4.95	4.97
45.	4.85	4.87	4.89	4.91	4.93	4.95	4.97	4.99	
44.	4.89	4.91	4.93	4.95	4.97	4.99			
43.	4.93	4.95	4.97						
42.	4.97	4.99							
41.									
40.									
39.									
38.									
37.									
36.									
35.									
34.									
33.									
32.									
31.									
30.									
29.									
28.									
27.									
26.									
25.									
24.									
23.									
22.									
21.									
20.									
19.									
18.									
17.									
16.									
15.									
14.									
13.									
12.									
11.									
10.									
9.									
8.									
7.									
6.									
5.									
4.									
3.									
2.									
1.									
0.									
-1.									
-2.									
-3.									
-4.									
-5.									
-6.									
-7.									
-8.									
-9.									
-10.									
-11.									
-12.									
-13.									
-14.									
-15.									
-16.									
-17.									
-18.									
-19.									
-20.									
	13.50	13.51	13.52	13.53	13.54	13.55	13.56	13.57	13.58
	Heater Resistance (Ohm) ----->								

GO TO NEXT PAGE

12.56. BLADE DE-ICE CONTROLLER ADJUSTMENT - continued

TABLE I. MAIN ROTOR BLADE ADJUSTMENT CHARTS (cont)

Blade Temp. (°C)	Main Rotor Adjustment Resistance (Kiloohm)								
	4.83	4.85	4.87	4.89	4.91	4.93	4.95	4.98	5.00
50.	4.83	4.85	4.87	4.89	4.91	4.93	4.95	4.98	5.00
49.	4.87	4.89	4.91	4.93	4.95	4.97	4.99		
48.	4.91	4.93	4.95	4.97	4.99				
47.	4.95	4.97	4.99						
46.	4.99								
45.									
44.									
43.									
42.									
41.									
40.									
39.									
38.									
37.									
36.									
35.									
34.									
33.									
32.									
31.									
30.									
29.									
28.									
27.									
26.									
25.									
24.									
23.									
22.									
21.									
20.									
19.									
18.									
17.									
16.									
15.									
14.									
13.									
12.									
11.									
10.									
9.									
8.									
7.									
6.									
5.									
4.									
3.									
2.									
1.									
0.									
-1.									
-2.									
-3.									
-4.									
-5.									
-6.									
-7.									
-8.									
-9.									
-10.									
-11.									
-12.									
-13.									
-14.									
-15.									
-16.									
-17.									
-18.									
-19.									
-20.									
	13.59	13.60	13.61	13.62	13.63	13.64	13.65	13.66	13.67
	Heater Resistance (Ohm) ----->								

GO TO NEXT PAGE

12.56. BLADE DE-ICE CONTROLLER ADJUSTMENT - continued

TABLE II. TAIL ROTOR BLADE ADJUSTMENT CHARTS

Blade Temp. (°C)	Tail Rotor Adjustment Resistance (kiloohm)								
	8.86	8.87	8.88	8.89	8.90	8.91	8.92	8.93	8.94
50.									
49.									
48.									
47.									
46.									
45.									
44.									
43.									
42.									
41.									
40.									
39.									
38.									
37.									
36.									
35.									
34.									
33.									
32.									
31.									
30.									
29.									
28.									
27.									
26.									
25.									
24.									
23.									
22.									
21.									
20.									
19.									
18.									
17.									
16.									
15.									
14.									
13.									
12.									
11.									
10.									
9.									
8.									
7.									
6.									
5.									
4.									
3.									
2.									
1.									
0.									
-1.									
-2.									
-3.									
-4.									
-5.									
-6.									
-7.									
-8.									
-9.									
-10.									
-11.									
-12.									
-13.									
-14.									
-15.									
-16.						0.01	0.03	0.02	0.05
-17.				0.01	0.03	0.02	0.04	0.06	0.08
-18.			0.02	0.04	0.06	0.05	0.07	0.09	0.12
-19.		0.03	0.05	0.07	0.09	0.08	0.11	0.13	0.15
-20.	0.00	0.03	0.05	0.07	0.09	0.12	0.14	0.16	0.18
	8.86	8.87	8.88	8.89	8.90	8.91	8.92	8.93	8.94
	Heater Resistance (Ohm) ----->								

GO TO NEXT PAGE

12.56. BLADE DE-ICE CONTROLLER ADJUSTMENT - continued

TABLE II. TAIL ROTOR BLADE ADJUSTMENT CHARTS (cont)

Blade Temp. (°C)	Tail Rotor Adjustment Resistance (kiloohm)								
	8.95	8.96	8.97	8.98	8.99	9.00	9.01	9.02	9.03
50.									
49.									
48.									
47.									
46.									
45.									
44.									
43.									
42.									
41.									
40.									
39.									
38.									
37.									
36.									
35.									
34.									
33.									
32.									
31.									
30.									
29.									
28.									
27.									
26.									
25.									
24.									
23.									
22.									
21.									
20.									
19.									
18.									
17.									
16.									
15.									
14.									
13.									
12.									
11.									
10.									
9.									
8.									
7.									
6.									
5.									
4.									
3.									
2.									
1.									
0.									
-1.									
-2.									
-3.									
-4.									
-5.									
-6.									
-7.									
-8.									
-9.									0.02
-10.							0.01	0.03	0.05
-11.						0.02	0.04	0.06	0.09
-12.				0.01	0.03	0.05	0.07	0.10	0.12
-13.			0.02	0.04	0.06	0.09	0.11	0.13	0.15
-14.	0.01	0.03	0.05	0.07	0.10	0.12	0.14	0.16	0.18
-15.	0.04	0.06	0.08	0.11	0.13	0.15	0.17	0.20	0.22
-16.	0.07	0.10	0.12	0.14	0.16	0.18	0.21	0.23	0.25
-17.	0.11	0.13	0.15	0.17	0.20	0.22	0.24	0.26	0.28
-18.	0.14	0.16	0.18	0.21	0.23	0.25	0.27	0.30	0.32
-19.	0.17	0.19	0.22	0.24	0.26	0.28	0.31	0.33	0.35
-20.	0.21	0.23	0.25	0.27	0.30	0.32	0.34	0.36	0.38

Heater Resistance (Ohm) ----->

GO TO NEXT PAGE

12.56. BLADE DE-ICE CONTROLLER ADJUSTMENT - continued

TABLE II. TAIL ROTOR BLADE ADJUSTMENT CHARTS (cont)

Blade Temp. (°C)	Tail Rotor Adjustment Resistance (kiloohm)								
	9.04	9.05	9.06	9.07	9.08	9.09	9.10	9.11	9.12
50.									
49.									
48.									
47.									
46.									
45.									
44.									
43.									
42.									
41.									
40.									
39.									
38.									
37.									
36.									
35.									
34.									
33.									
32.									
31.									
30.									
29.									
28.									
27.									
26.									
25.									
24.									
23.									
22.									
21.									
20.									
19.									
18.									
17.									
16.									
15.									
14.									
13.									
12.									
11.									
10.									
9.									
8.									
7.									
6.									
5.									
4.									
3.									
2.									
1.									
0.									
-1.									
-2.									
-3.								0.00	0.02
-4.							0.01	0.03	0.06
-5.					0.00	0.02	0.04	0.07	0.09
-6.		0.00	0.02	0.01	0.03	0.06	0.08	0.10	0.12
-7.		0.03	0.05	0.04	0.07	0.09	0.11	0.13	0.15
-8.	0.01	0.03	0.05	0.08	0.10	0.12	0.14	0.16	0.19
-9.	0.04	0.07	0.09	0.11	0.13	0.15	0.18	0.20	0.22
-10.	0.08	0.10	0.12	0.14	0.16	0.19	0.21	0.23	0.25
-11.	0.11	0.13	0.15	0.17	0.20	0.22	0.24	0.26	0.28
-12.	0.14	0.16	0.19	0.21	0.23	0.25	0.27	0.30	0.32
-13.	0.17	0.20	0.22	0.24	0.26	0.28	0.31	0.33	0.35
-14.	0.21	0.23	0.25	0.27	0.30	0.32	0.34	0.36	0.38
-15.	0.24	0.26	0.28	0.31	0.33	0.35	0.37	0.40	0.42
-16.	0.27	0.30	0.32	0.34	0.36	0.38	0.41	0.43	0.45
-17.	0.31	0.33	0.35	0.37	0.40	0.42	0.44	0.46	0.48
-18.	0.34	0.36	0.38	0.41	0.43	0.45	0.47	0.50	0.52
-19.	0.37	0.40	0.42	0.44	0.46	0.49	0.51	0.53	0.55
-20.	0.41	0.43	0.45	0.47	0.50	0.52	0.54	0.56	0.59
	9.04	9.05	9.06	9.07	9.08	9.09	9.10	9.11	9.12
	Heater Resistance (Ohm) ----->								

GO TO NEXT PAGE

12.56. BLADE DE-ICE CONTROLLER ADJUSTMENT - continued

TABLE II. TAIL ROTOR BLADE ADJUSTMENT CHARTS (cont)

Blade Temp. (°C)	Tail Rotor Adjustment Resistance (kiloohm)								
	9.13	9.14	9.15	9.16	9.17	9.18	9.19	9.20	9.21
50.									
49.									
48.									
47.									
46.									
45.									
44.									
43.									
42.									
41.									
40.									
39.									
38.									
37.									
36.									
35.									
34.									
33.									
32.									
31.									
30.									
29.									
28.									
27.									
26.									
25.									
24.									
23.									
22.									
21.									
20.									
19.									
18.									
17.									
16.									
15.									
14.									
13.									
12.									
11.									
10.									
9.									
8.									
7.									
6.									
5.									
4.									
3.								0.01	0.03
2.							0.02	0.04	0.06
1.					0.00	0.03	0.05	0.07	0.09
0.				0.01	0.04	0.06	0.08	0.10	0.12
-1.		0.00	0.02	0.05	0.07	0.09	0.11	0.13	0.16
-2.	0.01	0.04	0.06	0.08	0.10	0.12	0.14	0.17	0.19
-3.	0.05	0.07	0.09	0.11	0.13	0.15	0.18	0.20	0.22
-4.	0.08	0.10	0.12	0.14	0.17	0.19	0.21	0.23	0.25
-5.	0.11	0.13	0.15	0.18	0.20	0.22	0.24	0.26	0.29
-6.	0.14	0.16	0.19	0.21	0.23	0.25	0.27	0.30	0.32
-7.	0.18	0.20	0.22	0.24	0.26	0.29	0.31	0.33	0.35
-8.	0.21	0.23	0.25	0.27	0.30	0.32	0.34	0.36	0.38
-9.	0.24	0.26	0.28	0.31	0.33	0.35	0.37	0.39	0.42
-10.	0.27	0.30	0.32	0.34	0.36	0.38	0.41	0.43	0.45
-11.	0.31	0.33	0.35	0.37	0.40	0.42	0.44	0.46	0.48
-12.	0.34	0.36	0.38	0.41	0.43	0.45	0.47	0.49	0.52
-13.	0.37	0.40	0.42	0.44	0.46	0.48	0.51	0.53	0.55
-14.	0.41	0.43	0.45	0.47	0.50	0.52	0.54	0.56	0.58
-15.	0.44	0.46	0.48	0.51	0.53	0.55	0.57	0.60	0.62
-16.	0.47	0.50	0.52	0.54	0.56	0.58	0.61	0.63	0.65
-17.	0.51	0.53	0.55	0.57	0.60	0.62	0.64	0.66	0.69
-18.	0.54	0.56	0.59	0.61	0.63	0.65	0.67	0.70	0.72
-19.	0.57	0.60	0.62	0.64	0.66	0.69	0.71	0.73	0.75
-20.	0.61	0.63	0.65	0.68	0.70	0.72	0.74	0.77	0.79
	9.13	9.14	9.15	9.16	9.17	9.18	9.19	9.20	9.21

Heater Resistance (Ohm) ----->

GO TO NEXT PAGE

12.56. BLADE DE-ICE CONTROLLER ADJUSTMENT - continued

TABLE II. TAIL ROTOR BLADE ADJUSTMENT CHARTS (cont)

Blade Temp. (°C)	Tail Rotor Adjustment Resistance (kiloohm)								
50.									
49.									
48.									
47.									
46.									
45.									
44.									
43.									
42.									
41.									
40.									
39.									
38.									
37.									
36.									
35.									
34.									
33.									
32.									
31.									
30.									
29.									
28.									
27.									
26.									
25.									
24.									
23.									
22.									
21.									
20.									
19.									
18.									
17.									
16.									
15.									
14.									
13.									
12.									
11.									
10.									
9.								0.01	0.03
8.							0.02	0.04	0.06
7.					0.01	0.03	0.05	0.07	0.09
6.				0.02	0.04	0.06	0.08	0.10	0.13
5.		0.01	0.03	0.05	0.07	0.09	0.11	0.14	0.16
4.	0.02	0.04	0.06	0.08	0.10	0.12	0.15	0.17	0.19
3.	0.05	0.07	0.09	0.11	0.13	0.16	0.18	0.20	0.22
2.	0.08	0.10	0.12	0.15	0.17	0.19	0.21	0.23	0.25
1.	0.11	0.13	0.16	0.18	0.20	0.22	0.24	0.26	0.29
0.	0.14	0.17	0.19	0.21	0.23	0.25	0.27	0.30	0.32
-1.	0.18	0.20	0.22	0.24	0.26	0.29	0.31	0.33	0.35
-2.	0.21	0.23	0.25	0.27	0.30	0.32	0.34	0.36	0.38
-3.	0.24	0.26	0.29	0.31	0.33	0.35	0.37	0.39	0.42
-4.	0.27	0.30	0.32	0.34	0.36	0.38	0.41	0.43	0.45
-5.	0.31	0.33	0.35	0.37	0.39	0.42	0.44	0.46	0.48
-6.	0.34	0.36	0.38	0.41	0.43	0.45	0.47	0.49	0.52
-7.	0.37	0.39	0.42	0.44	0.46	0.48	0.50	0.53	0.55
-8.	0.41	0.43	0.45	0.47	0.49	0.52	0.54	0.56	0.58
-9.	0.44	0.46	0.48	0.50	0.53	0.55	0.57	0.59	0.61
-10.	0.47	0.49	0.52	0.54	0.56	0.58	0.60	0.63	0.65
-11.	0.51	0.53	0.55	0.57	0.59	0.62	0.64	0.66	0.68
-12.	0.54	0.56	0.58	0.61	0.63	0.65	0.67	0.69	0.72
-13.	0.57	0.59	0.62	0.64	0.66	0.68	0.71	0.73	0.75
-14.	0.61	0.63	0.65	0.67	0.69	0.72	0.74	0.76	0.78
-15.	0.64	0.66	0.68	0.71	0.73	0.75	0.77	0.80	0.82
-16.	0.67	0.70	0.72	0.74	0.76	0.78	0.81	0.83	0.85
-17.	0.71	0.73	0.75	0.77	0.80	0.82	0.84	0.86	0.89
-18.	0.74	0.76	0.79	0.81	0.83	0.85	0.88	0.90	0.92
-19.	0.78	0.80	0.82	0.84	0.87	0.89	0.91	0.93	0.95
-20.	0.81	0.83	0.85	0.88	0.90	0.92	0.94	0.97	0.99
	9.22	9.23	9.24	9.25	9.26	9.27	9.28	9.29	9.30
	Heater Resistance (Ohm) ----->								

GO TO NEXT PAGE

12.56. BLADE DE-ICE CONTROLLER ADJUSTMENT - continued

TABLE II. TAIL ROTOR BLADE ADJUSTMENT CHARTS (cont)

Blade Temp. (°C)	Tail Rotor Adjustment Resistance (kiloohm)									
50.										
49.										
48.										
47.										
46.										
45.										
44.										
43.										
42.										
41.										
40.										
39.										
38.										
37.										
36.										
35.										
34.										
33.										
32.										
31.										
30.										
29.										
28.										
27.										
26.										
25.										
24.										
23.										
22.										
21.										
20.										
19.										
18.										
17.										
16.										0.00
15.								0.01		0.03
14.						0.00	0.02	0.04		0.06
13.					0.01	0.03	0.05	0.07		0.10
12.				0.02	0.04	0.06	0.08	0.11		0.13
11.		0.01	0.03	0.05	0.07	0.09	0.12	0.14		0.16
10.	0.02	0.04	0.06	0.08	0.11	0.13	0.15	0.17		0.19
9.	0.05	0.07	0.09	0.12	0.14	0.16	0.18	0.20		0.22
8.	0.08	0.10	0.13	0.15	0.17	0.19	0.21	0.23		0.25
7.	0.11	0.14	0.16	0.18	0.20	0.22	0.24	0.26		0.29
6.	0.15	0.17	0.19	0.21	0.23	0.25	0.28	0.30		0.32
5.	0.18	0.20	0.22	0.24	0.26	0.29	0.31	0.33		0.35
4.	0.21	0.23	0.25	0.28	0.30	0.32	0.34	0.36		0.38
3.	0.24	0.26	0.29	0.31	0.33	0.35	0.37	0.39		0.42
2.	0.28	0.30	0.32	0.34	0.36	0.38	0.40	0.43		0.45
1.	0.31	0.33	0.35	0.37	0.39	0.42	0.44	0.46		0.48
0.	0.34	0.36	0.38	0.41	0.43	0.45	0.47	0.49		0.51
-1.	0.37	0.39	0.42	0.44	0.46	0.48	0.50	0.52		0.55
-2.	0.41	0.43	0.45	0.47	0.49	0.51	0.54	0.56		0.58
-3.	0.44	0.46	0.48	0.50	0.53	0.55	0.57	0.59		0.61
-4.	0.47	0.49	0.51	0.54	0.56	0.58	0.60	0.62		0.65
-5.	0.50	0.53	0.55	0.57	0.59	0.61	0.64	0.66		0.68
-6.	0.54	0.56	0.58	0.60	0.62	0.65	0.67	0.69		0.71
-7.	0.57	0.59	0.61	0.64	0.66	0.68	0.70	0.72		0.75
-8.	0.60	0.63	0.65	0.67	0.69	0.71	0.74	0.76		0.78
-9.	0.64	0.66	0.68	0.70	0.72	0.75	0.77	0.79		0.81
-10.	0.67	0.69	0.71	0.74	0.76	0.78	0.80	0.82		0.85
-11.	0.70	0.73	0.75	0.77	0.79	0.81	0.84	0.86		0.88
-12.	0.74	0.76	0.78	0.80	0.83	0.85	0.87	0.89		0.91
-13.	0.77	0.79	0.82	0.84	0.86	0.88	0.90	0.93		0.95
-14.	0.81	0.83	0.85	0.87	0.89	0.92	0.94	0.96		0.98
-15.	0.84	0.86	0.88	0.91	0.93	0.95	0.97	1.00		1.02
-16.	0.87	0.90	0.92	0.94	0.96	0.98	1.01	1.03		1.05
-17.	0.91	0.93	0.95	0.97	1.00	1.02	1.04	1.06		1.09
-18.	0.94	0.96	0.99	1.01	1.03	1.05	1.08	1.10		1.12
-19.	0.98	1.00	1.02	1.04	1.07	1.09	1.11	1.13		1.16
-20.	1.01	1.03	1.06	1.08	1.10	1.12	1.15	1.17		1.19
	9.31	9.32	9.33	9.34	9.35	9.36	9.37	9.38	9.39	
	Heater Resistance (Ohm) ----->									

GO TO NEXT PAGE



12.56. BLADE DE-ICE CONTROLLER ADJUSTMENT - continued

TABLE II. TAIL ROTOR BLADE ADJUSTMENT CHARTS (cont)

Blade Temp. (°C)	Tail Rotor Adjustment Resistance (kiloohm)								
50.									
49.									
48.									
47.									
46.									
45.									
44.									
43.									
42.									
41.									
40.									
39.									
38.									
37.									
36.									
35.									
34.									
33.									
32.									
31.									
30.									
29.									
28.									
27.									
26.									
25.									
24.									
23.									
22.									0.00
21.								0.01	0.04
20.						0.00	0.02	0.05	0.07
19.					0.01	0.03	0.06	0.08	0.10
18.			0.00	0.02	0.04	0.07	0.09	0.11	0.13
17.		0.01	0.03	0.05	0.08	0.10	0.12	0.14	0.16
16.	0.02	0.04	0.06	0.09	0.11	0.13	0.15	0.17	0.19
15.	0.05	0.08	0.10	0.12	0.14	0.16	0.18	0.20	0.22
14.	0.09	0.11	0.13	0.15	0.17	0.19	0.21	0.23	0.26
13.	0.12	0.14	0.16	0.18	0.20	0.22	0.24	0.27	0.29
12.	0.15	0.17	0.19	0.21	0.23	0.25	0.28	0.30	0.32
11.	0.18	0.20	0.22	0.24	0.27	0.29	0.31	0.33	0.35
10.	0.21	0.23	0.25	0.28	0.30	0.32	0.34	0.36	0.38
9.	0.24	0.27	0.29	0.31	0.33	0.35	0.37	0.39	0.41
8.	0.28	0.30	0.32	0.34	0.36	0.38	0.40	0.43	0.45
7.	0.31	0.33	0.35	0.37	0.39	0.42	0.44	0.46	0.48
6.	0.34	0.36	0.38	0.40	0.43	0.45	0.47	0.49	0.51
5.	0.37	0.39	0.42	0.44	0.46	0.48	0.50	0.52	0.54
4.	0.40	0.43	0.45	0.47	0.49	0.51	0.53	0.56	0.58
3.	0.44	0.46	0.48	0.50	0.52	0.55	0.57	0.59	0.61
2.	0.47	0.49	0.51	0.53	0.56	0.58	0.60	0.62	0.64
1.	0.50	0.52	0.55	0.57	0.59	0.61	0.63	0.65	0.68
0.	0.54	0.56	0.58	0.60	0.62	0.64	0.67	0.69	0.71
-1.	0.57	0.59	0.61	0.63	0.66	0.68	0.70	0.72	0.74
-2.	0.60	0.62	0.64	0.67	0.69	0.71	0.73	0.75	0.78
-3.	0.63	0.66	0.68	0.70	0.72	0.74	0.77	0.79	0.81
-4.	0.67	0.69	0.71	0.73	0.75	0.78	0.80	0.82	0.84
-5.	0.70	0.72	0.74	0.77	0.79	0.81	0.83	0.85	0.88
-6.	0.73	0.76	0.78	0.80	0.82	0.84	0.87	0.89	0.91
-7.	0.77	0.79	0.81	0.83	0.86	0.88	0.90	0.92	0.94
-8.	0.80	0.82	0.85	0.87	0.89	0.91	0.93	0.95	0.98
-9.	0.83	0.86	0.88	0.90	0.92	0.94	0.97	0.99	1.01
-10.	0.87	0.89	0.91	0.93	0.96	0.98	1.00	1.02	1.05
-11.	0.90	0.92	0.95	0.97	0.99	1.01	1.04	1.06	1.08
-12.	0.94	0.96	0.98	1.00	1.03	1.05	1.07	1.09	1.11
-13.	0.97	0.99	1.02	1.04	1.06	1.08	1.10	1.13	1.15
-14.	1.01	1.03	1.05	1.07	1.09	1.12	1.14	1.16	1.18
-15.	1.04	1.06	1.08	1.11	1.13	1.15	1.17	1.19	1.22
-16.	1.07	1.10	1.12	1.14	1.16	1.19	1.21	1.23	1.25
-17.	1.11	1.13	1.15	1.18	1.20	1.22	1.24	1.26	1.29
-18.	1.14	1.17	1.19	1.21	1.23	1.25	1.28	1.30	1.32
-19.	1.18	1.20	1.22	1.25	1.27	1.29	1.31	1.33	1.36
-20.	1.21	1.24	1.26	1.28	1.30	1.32	1.35	1.37	1.39
	9.40	9.41	9.42	9.43	9.44	9.45	9.46	9.47	9.48
	Heater Resistance (Ohm) ----->								

GO TO NEXT PAGE

12.56. BLADE DE-ICE CONTROLLER ADJUSTMENT - continued

TABLE II. TAIL ROTOR BLADE ADJUSTMENT CHARTS (cont)

Blade Temp. (°C)	Tail Rotor Adjustment Resistance (kiloohm)								
	9.49	9.50	9.51	9.52	9.53	9.54	9.55	9.56	9.57
50.									
49.									
48.									
47.									
46.									
45.									
44.									
43.									
42.									
41.									
40.									
39.									
38.									
37.									
36.									
35.									
34.									
33.									
32.									
31.									
30.									
29.									
28.									0.01
27.								0.02	0.04
26.								0.05	0.07
25.					0.02	0.04	0.06	0.08	0.10
24.			0.01	0.03	0.05	0.07	0.09	0.11	0.13
23.		0.02	0.04	0.06	0.08	0.10	0.12	0.14	0.16
22.	0.03	0.05	0.07	0.09	0.11	0.13	0.15	0.17	0.19
21.	0.06	0.08	0.10	0.12	0.14	0.16	0.18	0.20	0.22
20.	0.09	0.11	0.13	0.15	0.17	0.19	0.21	0.23	0.26
19.	0.12	0.14	0.16	0.18	0.20	0.22	0.25	0.27	0.29
18.	0.15	0.17	0.19	0.21	0.23	0.26	0.28	0.30	0.32
17.	0.18	0.20	0.22	0.24	0.27	0.29	0.31	0.33	0.35
16.	0.21	0.23	0.26	0.28	0.30	0.32	0.34	0.36	0.38
15.	0.24	0.27	0.29	0.31	0.33	0.35	0.37	0.39	0.41
14.	0.28	0.30	0.32	0.34	0.36	0.38	0.40	0.43	0.45
13.	0.31	0.33	0.35	0.37	0.39	0.41	0.44	0.46	0.48
12.	0.34	0.36	0.38	0.40	0.43	0.45	0.47	0.49	0.51
11.	0.37	0.39	0.41	0.44	0.46	0.48	0.50	0.52	0.54
10.	0.40	0.43	0.45	0.47	0.49	0.51	0.53	0.55	0.58
9.	0.44	0.46	0.48	0.50	0.52	0.54	0.56	0.59	0.61
8.	0.47	0.49	0.51	0.53	0.55	0.58	0.60	0.62	0.64
7.	0.50	0.52	0.54	0.57	0.59	0.61	0.63	0.65	0.67
6.	0.53	0.56	0.58	0.60	0.62	0.64	0.66	0.68	0.71
5.	0.57	0.59	0.61	0.63	0.65	0.67	0.70	0.72	0.74
4.	0.60	0.62	0.64	0.66	0.69	0.71	0.73	0.75	0.77
3.	0.63	0.65	0.67	0.70	0.72	0.74	0.76	0.78	0.80
2.	0.66	0.69	0.71	0.73	0.75	0.77	0.79	0.82	0.84
1.	0.70	0.72	0.74	0.76	0.78	0.81	0.83	0.85	0.87
0.	0.73	0.75	0.77	0.80	0.82	0.84	0.86	0.88	0.90
-1.	0.76	0.79	0.81	0.83	0.85	0.87	0.89	0.92	0.94
-2.	0.80	0.82	0.84	0.86	0.88	0.91	0.93	0.95	0.97
-3.	0.83	0.85	0.87	0.90	0.92	0.94	0.96	0.98	1.00
-4.	0.86	0.89	0.91	0.93	0.95	0.97	0.99	1.02	1.04
-5.	0.90	0.92	0.94	0.96	0.98	1.01	1.03	1.05	1.07
-6.	0.93	0.95	0.97	1.00	1.02	1.04	1.06	1.08	1.11
-7.	0.97	0.99	1.01	1.03	1.05	1.07	1.10	1.12	1.14
-8.	1.00	1.02	1.04	1.06	1.09	1.11	1.13	1.15	1.17
-9.	1.03	1.05	1.08	1.10	1.12	1.14	1.16	1.19	1.21
-10.	1.07	1.09	1.11	1.13	1.16	1.18	1.20	1.22	1.24
-11.	1.10	1.12	1.15	1.17	1.19	1.21	1.23	1.26	1.28
-12.	1.14	1.16	1.18	1.20	1.22	1.25	1.27	1.29	1.31
-13.	1.17	1.19	1.21	1.24	1.26	1.28	1.30	1.33	1.35
-14.	1.20	1.23	1.25	1.27	1.29	1.32	1.34	1.36	1.38
-15.	1.24	1.26	1.28	1.31	1.33	1.35	1.37	1.39	1.42
-16.	1.27	1.30	1.32	1.34	1.36	1.39	1.41	1.43	1.45
-17.	1.31	1.33	1.35	1.38	1.40	1.42	1.44	1.46	1.49
-18.	1.34	1.37	1.39	1.41	1.43	1.46	1.48	1.50	1.52
-19.	1.38	1.40	1.42	1.45	1.47	1.49	1.51	1.54	1.56
-20.	1.41	1.44	1.46	1.48	1.50	1.53	1.55	1.57	1.59
	9.49	9.50	9.51	9.52	9.53	9.54	9.55	9.56	9.57

Heater Resistance (Ohm) ----->

GO TO NEXT PAGE

12.56. BLADE DE-ICE CONTROLLER ADJUSTMENT - continued

TABLE II. TAIL ROTOR BLADE ADJUSTMENT CHARTS (cont)

Blade Temp. (°C)	Tail Rotor Adjustment Resistance (kiloohm)								
50.									
49.									
48.									
47.									
46.									
45.									
44.									
43.									
42.									
41.									
40.									
39.									
38.									
37.									
36.									
35.									
34.									0.01
33.							0.02		0.04
32.						0.01	0.05		0.07
31.					0.02	0.04	0.06	0.08	0.10
30.			0.01	0.03	0.05	0.07	0.09	0.11	0.13
29.		0.02	0.04	0.06	0.08	0.10	0.12	0.14	0.16
28.	0.03	0.05	0.07	0.09	0.11	0.13	0.15	0.17	0.19
27.	0.06	0.08	0.10	0.12	0.14	0.16	0.18	0.20	0.23
26.	0.09	0.11	0.13	0.15	0.17	0.19	0.22	0.24	0.26
25.	0.12	0.14	0.16	0.18	0.20	0.23	0.25	0.27	0.29
24.	0.15	0.17	0.19	0.21	0.24	0.26	0.28	0.30	0.32
23.	0.18	0.20	0.22	0.25	0.27	0.29	0.31	0.33	0.35
22.	0.21	0.24	0.26	0.28	0.30	0.32	0.34	0.36	0.38
21.	0.25	0.27	0.29	0.31	0.33	0.35	0.37	0.39	0.41
20.	0.28	0.30	0.32	0.34	0.36	0.38	0.40	0.42	0.45
19.	0.31	0.33	0.35	0.37	0.39	0.41	0.43	0.46	0.48
18.	0.34	0.36	0.38	0.40	0.42	0.45	0.47	0.49	0.51
17.	0.37	0.39	0.41	0.44	0.46	0.48	0.50	0.52	0.54
16.	0.40	0.42	0.45	0.47	0.49	0.51	0.53	0.55	0.57
15.	0.44	0.46	0.48	0.50	0.52	0.54	0.56	0.58	0.61
14.	0.47	0.49	0.51	0.53	0.55	0.57	0.59	0.62	0.64
13.	0.50	0.52	0.54	0.56	0.58	0.61	0.63	0.65	0.67
12.	0.53	0.55	0.57	0.60	0.62	0.64	0.66	0.68	0.70
11.	0.56	0.59	0.61	0.63	0.65	0.67	0.69	0.71	0.73
10.	0.60	0.62	0.64	0.66	0.68	0.70	0.72	0.75	0.77
9.	0.63	0.65	0.67	0.69	0.71	0.74	0.76	0.78	0.80
8.	0.66	0.68	0.70	0.73	0.75	0.77	0.79	0.81	0.83
7.	0.69	0.72	0.74	0.76	0.78	0.80	0.82	0.84	0.87
6.	0.73	0.75	0.77	0.79	0.81	0.83	0.86	0.88	0.90
5.	0.76	0.78	0.80	0.82	0.85	0.87	0.89	0.91	0.93
4.	0.79	0.81	0.84	0.86	0.88	0.90	0.92	0.94	0.97
3.	0.83	0.85	0.87	0.89	0.91	0.93	0.96	0.98	1.00
2.	0.86	0.88	0.90	0.92	0.95	0.97	0.99	1.01	1.03
1.	0.89	0.91	0.94	0.96	0.98	1.00	1.02	1.04	1.07
0.	0.93	0.95	0.97	0.99	1.01	1.03	1.06	1.08	1.10
-1.	0.96	0.98	1.00	1.02	1.05	1.07	1.09	1.11	1.13
-2.	0.99	1.01	1.04	1.06	1.08	1.10	1.12	1.15	1.17
-3.	1.03	1.05	1.07	1.09	1.11	1.14	1.16	1.18	1.20
-4.	1.06	1.08	1.10	1.13	1.15	1.17	1.19	1.21	1.23
-5.	1.09	1.12	1.14	1.16	1.18	1.20	1.23	1.25	1.27
-6.	1.13	1.15	1.17	1.19	1.22	1.24	1.26	1.28	1.30
-7.	1.16	1.18	1.21	1.23	1.25	1.27	1.29	1.32	1.34
-8.	1.20	1.22	1.24	1.26	1.28	1.31	1.33	1.35	1.37
-9.	1.23	1.25	1.27	1.30	1.32	1.34	1.36	1.38	1.41
-10.	1.27	1.29	1.31	1.33	1.35	1.38	1.40	1.42	1.44
-11.	1.30	1.32	1.34	1.37	1.39	1.41	1.43	1.45	1.48
-12.	1.33	1.36	1.38	1.40	1.42	1.45	1.47	1.49	1.51
-13.	1.37	1.39	1.41	1.44	1.46	1.48	1.50	1.52	1.55
-14.	1.40	1.43	1.45	1.47	1.49	1.52	1.54	1.56	1.58
-15.	1.44	1.46	1.48	1.51	1.53	1.55	1.57	1.59	1.62
-16.	1.47	1.50	1.52	1.54	1.56	1.59	1.61	1.63	1.65
-17.	1.51	1.53	1.55	1.58	1.60	1.62	1.64	1.67	1.69
-18.	1.54	1.57	1.59	1.61	1.63	1.66	1.68	1.70	1.72
-19.	1.58	1.60	1.62	1.65	1.67	1.69	1.71	1.74	1.76
-20.	1.62	1.64	1.66	1.68	1.71	1.73	1.75	1.77	1.79
	9.58	9.59	9.60	9.61	9.62	9.63	9.64	9.65	9.66

Heater Resistance (Ohm) ----->

GO TO NEXT PAGE

12.56. BLADE DE-ICE CONTROLLER ADJUSTMENT - continued

TABLE II. TAIL ROTOR BLADE ADJUSTMENT CHARTS (cont)

Blade Temp. (°C)	Tail Rotor Adjustment Resistance (kiloohm)								
	9.67	9.68	9.69	9.70	9.71	9.72	9.73	9.74	9.75
50.									0.01
49.									0.04
48.									0.07
47.									0.10
46.									0.13
45.									0.17
44.									0.20
43.									0.23
42.									0.26
41.									0.29
40.									0.32
39.							0.00		0.35
38.						0.01	0.03	0.02	0.38
37.				0.00	0.02	0.04	0.06	0.08	0.41
36.			0.01	0.03	0.05	0.07	0.09	0.11	0.44
35.	0.00	0.02	0.04	0.06	0.08	0.10	0.12	0.14	0.47
34.	0.03	0.05	0.07	0.09	0.11	0.13	0.15	0.18	0.50
33.	0.06	0.08	0.10	0.12	0.14	0.16	0.19	0.21	0.53
32.	0.09	0.11	0.13	0.15	0.17	0.20	0.22	0.24	0.55
31.	0.12	0.14	0.16	0.18	0.21	0.23	0.25	0.27	0.57
30.	0.15	0.17	0.20	0.22	0.24	0.26	0.28	0.30	0.60
29.	0.18	0.21	0.23	0.25	0.27	0.29	0.31	0.33	0.63
28.	0.22	0.24	0.26	0.28	0.30	0.32	0.34	0.36	0.65
27.	0.25	0.27	0.29	0.31	0.33	0.35	0.37	0.39	0.67
26.	0.28	0.30	0.32	0.34	0.36	0.38	0.40	0.42	0.70
25.	0.31	0.33	0.35	0.37	0.39	0.41	0.43	0.46	0.73
24.	0.34	0.36	0.38	0.40	0.42	0.44	0.47	0.49	0.76
23.	0.37	0.39	0.41	0.43	0.46	0.48	0.50	0.52	0.78
22.	0.40	0.42	0.45	0.47	0.49	0.51	0.53	0.55	0.81
21.	0.43	0.46	0.48	0.50	0.52	0.54	0.56	0.58	0.83
20.	0.47	0.49	0.51	0.53	0.55	0.57	0.59	0.61	0.86
19.	0.50	0.52	0.54	0.56	0.58	0.60	0.62	0.65	0.88
18.	0.53	0.55	0.57	0.59	0.61	0.64	0.66	0.68	0.91
17.	0.56	0.58	0.60	0.63	0.65	0.67	0.69	0.71	0.93
16.	0.59	0.62	0.64	0.66	0.68	0.70	0.72	0.74	0.96
15.	0.63	0.65	0.67	0.69	0.71	0.73	0.75	0.77	0.98
14.	0.66	0.68	0.70	0.72	0.74	0.76	0.79	0.81	1.00
13.	0.69	0.71	0.73	0.75	0.78	0.80	0.82	0.84	1.02
12.	0.72	0.74	0.77	0.79	0.81	0.83	0.85	0.87	1.04
11.	0.76	0.78	0.80	0.82	0.84	0.86	0.88	0.91	1.06
10.	0.79	0.81	0.83	0.85	0.87	0.90	0.92	0.94	1.08
9.	0.82	0.84	0.86	0.89	0.91	0.93	0.95	0.97	1.10
8.	0.85	0.88	0.90	0.92	0.94	0.96	0.98	1.00	1.13
7.	0.89	0.91	0.93	0.95	0.97	0.99	1.02	1.04	1.16
6.	0.92	0.94	0.96	0.98	1.01	1.03	1.05	1.07	1.19
5.	0.95	0.98	1.00	1.02	1.04	1.06	1.08	1.10	1.23
4.	0.99	1.01	1.03	1.05	1.07	1.09	1.12	1.14	1.26
3.	1.02	1.04	1.06	1.09	1.11	1.13	1.15	1.17	1.29
2.	1.05	1.08	1.10	1.12	1.14	1.16	1.18	1.21	1.33
1.	1.09	1.11	1.13	1.15	1.17	1.20	1.22	1.24	1.36
0.	1.12	1.14	1.16	1.19	1.21	1.23	1.25	1.27	1.40
-1.	1.15	1.18	1.20	1.22	1.24	1.26	1.29	1.31	1.43
-2.	1.19	1.21	1.23	1.25	1.28	1.30	1.32	1.34	1.47
-3.	1.22	1.24	1.27	1.29	1.31	1.33	1.35	1.38	1.50
-4.	1.26	1.28	1.30	1.32	1.34	1.37	1.39	1.41	1.54
-5.	1.29	1.31	1.33	1.36	1.38	1.40	1.42	1.44	1.57
-6.	1.33	1.35	1.37	1.39	1.41	1.43	1.46	1.48	1.60
-7.	1.36	1.38	1.40	1.43	1.45	1.47	1.49	1.51	1.64
-8.	1.39	1.42	1.44	1.46	1.48	1.50	1.53	1.55	1.68
-9.	1.43	1.45	1.47	1.49	1.52	1.54	1.56	1.58	1.71
-10.	1.46	1.49	1.51	1.53	1.55	1.57	1.60	1.62	1.75
-11.	1.50	1.52	1.54	1.56	1.59	1.61	1.63	1.65	1.78
-12.	1.53	1.56	1.58	1.60	1.62	1.64	1.67	1.69	1.82
-13.	1.57	1.59	1.61	1.63	1.66	1.68	1.70	1.72	1.85
-14.	1.60	1.63	1.65	1.67	1.69	1.71	1.74	1.76	1.89
-15.	1.64	1.66	1.68	1.71	1.73	1.75	1.77	1.79	1.92
-16.	1.67	1.70	1.72	1.74	1.76	1.79	1.81	1.83	1.96
-17.	1.71	1.73	1.75	1.78	1.80	1.82	1.84	1.87	2.00
-18.	1.75	1.77	1.79	1.81	1.83	1.86	1.88	1.90	
-19.	1.78	1.80	1.83	1.85	1.87	1.89	1.92	1.94	
-20.	1.82	1.84	1.86	1.88	1.91	1.93	1.95	1.97	
	9.67	9.68	9.69	9.70	9.71	9.72	9.73	9.74	9.75

Heater Resistance (Ohm) ----->

GO TO NEXT PAGE

12.56. BLADE DE-ICE CONTROLLER ADJUSTMENT - continued

TABLE II. TAIL ROTOR BLADE ADJUSTMENT CHARTS (cont)

Blade Temp. (°C)	Tail Rotor Adjustment Resistance (Kiloohm)								
	9.76	9.77	9.78	9.79	9.80	9.81	9.82	9.83	9.84
50.									0.02
49.									0.05
48.									0.08
47.									0.11
46.									0.14
45.							0.01	0.03	0.05
44.						0.02	0.04	0.06	0.08
43.				0.00	0.02	0.05	0.07	0.09	0.11
42.			0.01	0.03	0.05	0.08	0.10	0.12	0.14
41.	0.00	0.02	0.04	0.06	0.09	0.11	0.13	0.15	0.17
40.	0.03	0.05	0.07	0.09	0.12	0.14	0.16	0.18	0.20
39.	0.06	0.08	0.10	0.13	0.15	0.17	0.19	0.21	0.23
38.	0.09	0.11	0.14	0.16	0.18	0.20	0.22	0.24	0.26
37.	0.12	0.15	0.17	0.19	0.21	0.23	0.25	0.27	0.29
36.	0.16	0.18	0.20	0.22	0.24	0.26	0.28	0.30	0.32
35.	0.19	0.21	0.23	0.25	0.27	0.29	0.31	0.33	0.35
34.	0.22	0.24	0.26	0.28	0.30	0.32	0.34	0.36	0.38
33.	0.25	0.27	0.29	0.31	0.33	0.35	0.37	0.39	0.41
32.	0.28	0.30	0.32	0.34	0.36	0.38	0.40	0.42	0.44
31.	0.31	0.33	0.35	0.37	0.39	0.41	0.43	0.45	0.47
30.	0.34	0.36	0.38	0.40	0.42	0.44	0.46	0.49	0.51
29.	0.37	0.39	0.41	0.43	0.45	0.48	0.50	0.52	0.54
28.	0.40	0.42	0.44	0.46	0.49	0.51	0.53	0.55	0.57
27.	0.43	0.45	0.48	0.50	0.52	0.54	0.56	0.58	0.60
26.	0.47	0.49	0.51	0.53	0.55	0.57	0.59	0.61	0.63
25.	0.50	0.52	0.54	0.56	0.58	0.60	0.62	0.64	0.66
24.	0.53	0.55	0.57	0.59	0.61	0.63	0.65	0.67	0.70
23.	0.56	0.58	0.60	0.62	0.64	0.66	0.69	0.71	0.73
22.	0.59	0.61	0.63	0.65	0.68	0.70	0.72	0.74	0.76
21.	0.62	0.64	0.67	0.69	0.71	0.73	0.75	0.77	0.79
20.	0.66	0.68	0.70	0.72	0.74	0.76	0.78	0.80	0.82
19.	0.69	0.71	0.73	0.75	0.77	0.79	0.81	0.84	0.86
18.	0.72	0.74	0.76	0.78	0.80	0.83	0.85	0.87	0.89
17.	0.75	0.77	0.79	0.82	0.84	0.86	0.88	0.90	0.92
16.	0.78	0.81	0.83	0.85	0.87	0.89	0.91	0.93	0.95
15.	0.82	0.84	0.86	0.88	0.90	0.92	0.94	0.97	0.99
14.	0.85	0.87	0.89	0.91	0.93	0.96	0.98	1.00	1.02
13.	0.88	0.90	0.92	0.95	0.97	0.99	1.01	1.03	1.05
12.	0.92	0.94	0.96	0.98	1.00	1.02	1.04	1.06	1.09
11.	0.95	0.97	0.99	1.01	1.03	1.05	1.08	1.10	1.12
10.	0.98	1.00	1.02	1.05	1.07	1.09	1.11	1.13	1.15
9.	1.01	1.04	1.06	1.08	1.10	1.12	1.14	1.16	1.19
8.	1.05	1.07	1.09	1.11	1.13	1.15	1.18	1.20	1.22
7.	1.08	1.10	1.12	1.14	1.17	1.19	1.21	1.23	1.25
6.	1.11	1.14	1.16	1.18	1.20	1.22	1.24	1.26	1.29
5.	1.15	1.17	1.19	1.21	1.23	1.25	1.28	1.30	1.32
4.	1.18	1.20	1.22	1.25	1.27	1.29	1.31	1.33	1.35
3.	1.21	1.24	1.26	1.28	1.30	1.32	1.34	1.37	1.39
2.	1.25	1.27	1.29	1.31	1.33	1.36	1.38	1.40	1.42
1.	1.28	1.30	1.33	1.35	1.37	1.39	1.41	1.43	1.46
0.	1.32	1.34	1.36	1.38	1.40	1.42	1.45	1.47	1.49
-1.	1.35	1.37	1.39	1.42	1.44	1.46	1.48	1.50	1.52
-2.	1.38	1.41	1.43	1.45	1.47	1.49	1.52	1.54	1.56
-3.	1.42	1.44	1.46	1.48	1.51	1.53	1.55	1.57	1.59
-4.	1.45	1.48	1.50	1.52	1.54	1.56	1.58	1.61	1.63
-5.	1.49	1.51	1.53	1.55	1.58	1.60	1.62	1.64	1.66
-6.	1.52	1.54	1.57	1.59	1.61	1.63	1.65	1.68	1.70
-7.	1.56	1.58	1.60	1.62	1.64	1.67	1.69	1.71	1.73
-8.	1.59	1.61	1.64	1.66	1.68	1.70	1.72	1.75	1.77
-9.	1.63	1.65	1.67	1.69	1.71	1.74	1.76	1.78	1.80
-10.	1.66	1.68	1.71	1.73	1.75	1.77	1.79	1.82	1.84
-11.	1.70	1.72	1.74	1.76	1.79	1.81	1.83	1.85	1.87
-12.	1.73	1.75	1.78	1.80	1.82	1.84	1.86	1.89	1.91
-13.	1.77	1.79	1.81	1.83	1.86	1.88	1.90	1.92	1.94
-14.	1.80	1.83	1.85	1.87	1.89	1.91	1.94	1.96	1.98
-15.	1.84	1.86	1.88	1.91	1.93	1.95	1.97	1.99	2.02
-16.	1.87	1.90	1.92	1.94	1.96	1.99	2.01	2.03	2.05
-17.	1.91	1.93	1.95	1.98	2.00	2.02	2.04	2.07	2.09
-18.	1.95	1.97	1.99	2.01	2.04	2.06	2.08	2.10	2.12
-19.	1.98	2.00	2.03	2.05	2.07	2.09	2.12	2.14	2.16
-20.	2.02	2.04	2.06	2.09	2.11	2.13	2.15	2.18	2.20
	9.76	9.77	9.78	9.79	9.80	9.81	9.82	9.83	9.84

Heater Resistance (Ohm) ----->

GO TO NEXT PAGE

12.56. BLADE DE-ICE CONTROLLER ADJUSTMENT - continued

TABLE II. TAIL ROTOR BLADE ADJUSTMENT CHARTS (cont)

Blade Temp. (°C)	Tail Rotor Adjustment Resistance (Kiloohm)									
50.				0.01	0.03	0.02	0.04	0.05	0.07	0.08
49.				0.01	0.03	0.04	0.06	0.08	0.10	0.11
48.			0.02	0.04	0.06	0.08	0.10	0.12	0.14	0.14
47.	0.01	0.03	0.05	0.07	0.09	0.11	0.13	0.15	0.17	0.17
46.	0.04	0.06	0.08	0.10	0.12	0.14	0.16	0.18	0.20	0.20
45.	0.07	0.09	0.11	0.13	0.15	0.17	0.19	0.21	0.23	0.23
44.	0.10	0.12	0.14	0.16	0.18	0.20	0.22	0.24	0.26	0.26
43.	0.13	0.15	0.17	0.19	0.21	0.23	0.25	0.27	0.29	0.29
42.	0.16	0.18	0.20	0.22	0.24	0.26	0.28	0.30	0.32	0.32
41.	0.19	0.21	0.23	0.25	0.27	0.29	0.31	0.33	0.35	0.35
40.	0.22	0.24	0.26	0.28	0.30	0.32	0.34	0.36	0.38	0.38
39.	0.25	0.27	0.29	0.31	0.33	0.35	0.37	0.39	0.41	0.41
38.	0.28	0.30	0.32	0.34	0.36	0.38	0.40	0.42	0.44	0.44
37.	0.31	0.33	0.35	0.37	0.39	0.41	0.43	0.45	0.47	0.47
36.	0.34	0.36	0.38	0.40	0.42	0.44	0.46	0.48	0.50	0.50
35.	0.37	0.39	0.41	0.43	0.45	0.47	0.49	0.52	0.54	0.54
34.	0.40	0.42	0.44	0.46	0.48	0.51	0.53	0.55	0.57	0.57
33.	0.43	0.45	0.47	0.50	0.52	0.54	0.56	0.58	0.60	0.60
32.	0.46	0.48	0.51	0.53	0.55	0.57	0.59	0.61	0.63	0.63
31.	0.50	0.52	0.54	0.56	0.58	0.60	0.62	0.64	0.66	0.66
30.	0.53	0.55	0.57	0.59	0.61	0.63	0.65	0.67	0.69	0.69
29.	0.56	0.58	0.60	0.62	0.64	0.66	0.68	0.70	0.72	0.72
28.	0.59	0.61	0.63	0.65	0.67	0.69	0.71	0.74	0.76	0.76
27.	0.62	0.64	0.66	0.68	0.70	0.73	0.75	0.77	0.79	0.79
26.	0.65	0.67	0.69	0.72	0.74	0.76	0.78	0.80	0.82	0.82
25.	0.68	0.71	0.73	0.75	0.77	0.79	0.81	0.83	0.85	0.85
24.	0.72	0.74	0.76	0.78	0.80	0.82	0.84	0.86	0.88	0.88
23.	0.75	0.77	0.79	0.81	0.83	0.85	0.87	0.90	0.92	0.92
22.	0.78	0.80	0.82	0.84	0.86	0.89	0.91	0.93	0.95	0.95
21.	0.81	0.83	0.85	0.88	0.90	0.92	0.94	0.96	0.98	0.98
20.	0.85	0.87	0.89	0.91	0.93	0.95	0.97	0.99	1.01	1.01
19.	0.88	0.90	0.92	0.94	0.96	0.98	1.00	1.03	1.05	1.05
18.	0.91	0.93	0.95	0.97	0.99	1.02	1.04	1.06	1.08	1.08
17.	0.94	0.96	0.98	1.01	1.03	1.05	1.07	1.09	1.11	1.11
16.	0.98	1.00	1.02	1.04	1.06	1.08	1.10	1.12	1.14	1.14
15.	1.01	1.03	1.05	1.07	1.09	1.11	1.14	1.16	1.18	1.18
14.	1.04	1.06	1.08	1.10	1.13	1.15	1.17	1.19	1.21	1.21
13.	1.07	1.10	1.12	1.14	1.16	1.18	1.20	1.22	1.24	1.24
12.	1.11	1.13	1.15	1.17	1.19	1.21	1.23	1.26	1.28	1.28
11.	1.14	1.16	1.18	1.20	1.23	1.25	1.27	1.29	1.31	1.31
10.	1.17	1.19	1.22	1.24	1.26	1.28	1.30	1.32	1.34	1.34
9.	1.21	1.23	1.25	1.27	1.29	1.31	1.34	1.36	1.38	1.38
8.	1.24	1.26	1.28	1.30	1.33	1.35	1.37	1.39	1.41	1.41
7.	1.27	1.30	1.32	1.34	1.36	1.38	1.40	1.42	1.45	1.45
6.	1.31	1.33	1.35	1.37	1.39	1.41	1.44	1.46	1.48	1.48
5.	1.34	1.36	1.38	1.41	1.43	1.45	1.47	1.49	1.51	1.51
4.	1.37	1.40	1.42	1.44	1.46	1.48	1.50	1.53	1.55	1.55
3.	1.41	1.43	1.45	1.47	1.50	1.52	1.54	1.56	1.58	1.58
2.	1.44	1.46	1.49	1.51	1.53	1.55	1.57	1.59	1.62	1.62
1.	1.48	1.50	1.52	1.54	1.56	1.59	1.61	1.63	1.65	1.65
0.	1.51	1.53	1.55	1.58	1.60	1.62	1.64	1.66	1.69	1.69
-1.	1.55	1.57	1.59	1.61	1.63	1.65	1.68	1.70	1.72	1.72
-2.	1.58	1.60	1.62	1.65	1.67	1.69	1.71	1.73	1.75	1.75
-3.	1.61	1.64	1.66	1.68	1.70	1.72	1.75	1.77	1.79	1.79
-4.	1.65	1.67	1.69	1.72	1.74	1.76	1.78	1.80	1.82	1.82
-5.	1.68	1.71	1.73	1.75	1.77	1.79	1.82	1.84	1.86	1.86
-6.	1.72	1.74	1.76	1.79	1.81	1.83	1.85	1.87	1.89	1.89
-7.	1.75	1.78	1.80	1.82	1.84	1.86	1.89	1.91	1.93	1.93
-8.	1.79	1.81	1.83	1.86	1.88	1.90	1.92	1.94	1.97	1.97
-9.	1.82	1.85	1.87	1.89	1.91	1.93	1.96	1.98	2.00	2.00
-10.	1.86	1.88	1.90	1.93	1.95	1.97	1.99	2.01	2.04	2.04
-11.	1.90	1.92	1.94	1.96	1.98	2.01	2.03	2.05	2.07	2.07
-12.	1.93	1.95	1.98	2.00	2.02	2.04	2.06	2.09	2.11	2.11
-13.	1.97	1.99	2.01	2.03	2.06	2.08	2.10	2.12	2.14	2.14
-14.	2.00	2.02	2.05	2.07	2.09	2.11	2.14	2.16	2.18	2.18
-15.	2.04	2.06	2.08	2.11	2.13	2.15	2.17	2.19	2.22	2.22
-16.	2.07	2.10	2.12	2.14	2.16	2.19	2.21	2.23	2.25	2.25
-17.	2.11	2.13	2.16	2.18	2.20	2.22	2.24	2.27	2.29	2.29
-18.	2.15	2.17	2.19	2.21	2.24	2.26	2.28	2.30	2.33	2.33
-19.	2.18	2.21	2.23	2.25	2.27	2.30	2.32	2.34	2.36	2.36
-20.	2.22	2.24	2.26	2.29	2.31	2.33	2.35	2.38	2.40	2.40
	9.85	9.86	9.87	9.88	9.89	9.90	9.91	9.92	9.93	

Heater Resistance (Ohm) ----->

GO TO NEXT PAGE

12.56. BLADE DE-ICE CONTROLLER ADJUSTMENT - continued

TABLE II. TAIL ROTOR BLADE ADJUSTMENT CHARTS (cont)

Blade Temp. (°C)	Tail Rotor Adjustment Resistance (Kiloohm)									
	0.10	0.12	0.14	0.16	0.18	0.20	0.22	0.24	0.26	0.28
50.	0.10	0.12	0.14	0.16	0.18	0.20	0.22	0.24	0.26	0.28
49.	0.13	0.15	0.17	0.19	0.21	0.23	0.25	0.27	0.29	0.31
48.	0.16	0.18	0.20	0.22	0.24	0.26	0.28	0.30	0.32	0.34
47.	0.19	0.21	0.23	0.25	0.27	0.29	0.31	0.33	0.35	0.37
46.	0.22	0.24	0.26	0.28	0.30	0.32	0.34	0.36	0.38	0.40
45.	0.25	0.27	0.29	0.31	0.33	0.35	0.37	0.39	0.41	0.43
44.	0.28	0.30	0.32	0.34	0.36	0.38	0.40	0.42	0.44	0.46
43.	0.31	0.33	0.35	0.37	0.39	0.41	0.43	0.45	0.47	0.49
42.	0.34	0.36	0.38	0.40	0.42	0.44	0.46	0.48	0.50	0.52
41.	0.37	0.39	0.41	0.43	0.45	0.47	0.49	0.51	0.53	0.55
40.	0.40	0.42	0.44	0.46	0.48	0.50	0.52	0.54	0.56	0.58
39.	0.43	0.45	0.47	0.49	0.51	0.53	0.55	0.57	0.59	0.61
38.	0.46	0.48	0.50	0.52	0.54	0.56	0.58	0.60	0.62	0.64
37.	0.49	0.51	0.53	0.55	0.57	0.59	0.61	0.63	0.65	0.67
36.	0.52	0.54	0.56	0.58	0.60	0.62	0.64	0.66	0.68	0.70
35.	0.55	0.57	0.59	0.61	0.63	0.65	0.67	0.69	0.71	0.73
34.	0.58	0.60	0.62	0.64	0.66	0.68	0.70	0.72	0.74	0.76
33.	0.61	0.63	0.65	0.67	0.69	0.71	0.73	0.75	0.77	0.79
32.	0.64	0.66	0.68	0.70	0.72	0.74	0.76	0.78	0.80	0.82
31.	0.67	0.69	0.71	0.73	0.75	0.77	0.79	0.81	0.83	0.85
30.	0.70	0.72	0.74	0.76	0.78	0.80	0.82	0.84	0.86	0.88
29.	0.73	0.75	0.77	0.79	0.81	0.83	0.85	0.87	0.89	0.91
28.	0.76	0.78	0.80	0.82	0.84	0.86	0.88	0.90	0.92	0.94
27.	0.79	0.81	0.83	0.85	0.87	0.89	0.91	0.93	0.95	0.97
26.	0.82	0.84	0.86	0.88	0.90	0.92	0.94	0.96	0.98	1.00
25.	0.85	0.87	0.89	0.91	0.93	0.95	0.97	0.99	1.01	1.03
24.	0.88	0.90	0.92	0.94	0.96	0.98	1.00	1.02	1.04	1.06
23.	0.91	0.93	0.95	0.97	0.99	1.01	1.03	1.05	1.07	1.09
22.	0.94	0.96	0.98	1.00	1.02	1.04	1.06	1.08	1.10	1.12
21.	0.97	0.99	1.01	1.03	1.05	1.07	1.09	1.11	1.13	1.15
20.	1.00	1.02	1.04	1.06	1.08	1.10	1.12	1.14	1.16	1.18
19.	1.03	1.05	1.07	1.09	1.11	1.13	1.15	1.17	1.19	1.21
18.	1.06	1.08	1.10	1.12	1.14	1.16	1.18	1.20	1.22	1.24
17.	1.09	1.11	1.13	1.15	1.17	1.19	1.21	1.23	1.25	1.27
16.	1.12	1.14	1.16	1.18	1.20	1.22	1.24	1.26	1.28	1.30
15.	1.15	1.17	1.19	1.21	1.23	1.25	1.27	1.29	1.31	1.33
14.	1.18	1.20	1.22	1.24	1.26	1.28	1.30	1.32	1.34	1.36
13.	1.21	1.23	1.25	1.27	1.29	1.31	1.33	1.35	1.37	1.39
12.	1.24	1.26	1.28	1.30	1.32	1.34	1.36	1.38	1.40	1.42
11.	1.27	1.29	1.31	1.33	1.35	1.37	1.39	1.41	1.43	1.45
10.	1.30	1.32	1.34	1.36	1.38	1.40	1.42	1.44	1.46	1.48
9.	1.33	1.35	1.37	1.39	1.41	1.43	1.45	1.47	1.49	1.51
8.	1.36	1.38	1.40	1.42	1.44	1.46	1.48	1.50	1.52	1.54
7.	1.39	1.41	1.43	1.45	1.47	1.49	1.51	1.53	1.55	1.57
6.	1.42	1.44	1.46	1.48	1.50	1.52	1.54	1.56	1.58	1.60
5.	1.45	1.47	1.49	1.51	1.53	1.55	1.57	1.59	1.61	1.63
4.	1.48	1.50	1.52	1.54	1.56	1.58	1.60	1.62	1.64	1.66
3.	1.51	1.53	1.55	1.57	1.59	1.61	1.63	1.65	1.67	1.69
2.	1.54	1.56	1.58	1.60	1.62	1.64	1.66	1.68	1.70	1.72
1.	1.57	1.59	1.61	1.63	1.65	1.67	1.69	1.71	1.73	1.75
0.	1.60	1.62	1.64	1.66	1.68	1.70	1.72	1.74	1.76	1.78
-1.	1.63	1.65	1.67	1.69	1.71	1.73	1.75	1.77	1.79	1.81
-2.	1.66	1.68	1.70	1.72	1.74	1.76	1.78	1.80	1.82	1.84
-3.	1.69	1.71	1.73	1.75	1.77	1.79	1.81	1.83	1.85	1.87
-4.	1.72	1.74	1.76	1.78	1.80	1.82	1.84	1.86	1.88	1.90
-5.	1.75	1.77	1.79	1.81	1.83	1.85	1.87	1.89	1.91	1.93
-6.	1.78	1.80	1.82	1.84	1.86	1.88	1.90	1.92	1.94	1.96
-7.	1.81	1.83	1.85	1.87	1.89	1.91	1.93	1.95	1.97	1.99
-8.	1.84	1.86	1.88	1.90	1.92	1.94	1.96	1.98	2.00	2.02
-9.	1.87	1.89	1.91	1.93	1.95	1.97	1.99	2.01	2.03	2.05
-10.	1.90	1.92	1.94	1.96	1.98	2.00	2.02	2.04	2.06	2.08
-11.	1.93	1.95	1.97	1.99	2.01	2.03	2.05	2.07	2.09	2.11
-12.	1.96	1.98	2.00	2.02	2.04	2.06	2.08	2.10	2.12	2.14
-13.	1.99	2.01	2.03	2.05	2.07	2.09	2.11	2.13	2.15	2.17
-14.	2.02	2.04	2.06	2.08	2.10	2.12	2.14	2.16	2.18	2.20
-15.	2.05	2.07	2.09	2.11	2.13	2.15	2.17	2.19	2.21	2.23
-16.	2.08	2.10	2.12	2.14	2.16	2.18	2.20	2.22	2.24	2.26
-17.	2.11	2.13	2.15	2.17	2.19	2.21	2.23	2.25	2.27	2.29
-18.	2.14	2.16	2.18	2.20	2.22	2.24	2.26	2.28	2.30	2.32
-19.	2.17	2.19	2.21	2.23	2.25	2.27	2.29	2.31	2.33	2.35
-20.	2.20	2.22	2.24	2.26	2.28	2.30	2.32	2.34	2.36	2.38

Heater Resistance (Ohm) ----->

GO TO NEXT PAGE

12.56. BLADE DE-ICE CONTROLLER ADJUSTMENT - continued

TABLE II. TAIL ROTOR BLADE ADJUSTMENT CHARTS (cont)

Blade Temp. (°C)	Tail Rotor Adjustment Resistance (Kiloohm)									
	10.03	10.04	10.05	10.06	10.07	10.08	10.09	10.10	10.11	
50.	0.28	0.30	0.32	0.34	0.36	0.38	0.40	0.42	0.44	
49.	0.31	0.33	0.35	0.37	0.39	0.41	0.43	0.45	0.47	
48.	0.34	0.36	0.38	0.40	0.42	0.44	0.46	0.48	0.50	
47.	0.37	0.39	0.41	0.43	0.45	0.47	0.49	0.51	0.53	
46.	0.40	0.42	0.44	0.46	0.48	0.50	0.52	0.54	0.56	
45.	0.43	0.45	0.47	0.49	0.51	0.53	0.55	0.57	0.59	
44.	0.46	0.48	0.50	0.52	0.54	0.56	0.58	0.60	0.62	
43.	0.49	0.51	0.53	0.55	0.57	0.59	0.61	0.64	0.66	
42.	0.52	0.54	0.56	0.58	0.61	0.63	0.65	0.67	0.69	
41.	0.55	0.57	0.60	0.62	0.64	0.66	0.68	0.70	0.72	
40.	0.59	0.61	0.63	0.65	0.67	0.69	0.71	0.73	0.75	
39.	0.62	0.64	0.66	0.68	0.70	0.72	0.74	0.76	0.78	
38.	0.65	0.67	0.69	0.71	0.73	0.75	0.77	0.79	0.81	
37.	0.68	0.70	0.72	0.74	0.76	0.78	0.80	0.82	0.84	
36.	0.71	0.73	0.75	0.77	0.79	0.81	0.83	0.85	0.87	
35.	0.74	0.76	0.78	0.80	0.82	0.84	0.87	0.89	0.91	
34.	0.77	0.79	0.81	0.83	0.86	0.88	0.90	0.92	0.94	
33.	0.80	0.83	0.85	0.87	0.89	0.91	0.93	0.95	0.97	
32.	0.84	0.86	0.88	0.90	0.92	0.94	0.96	0.98	1.00	
31.	0.87	0.89	0.91	0.93	0.95	0.97	0.99	1.01	1.03	
30.	0.90	0.92	0.94	0.96	0.98	1.00	1.02	1.05	1.07	
29.	0.93	0.95	0.97	0.99	1.02	1.04	1.06	1.08	1.10	
28.	0.96	0.98	1.01	1.03	1.05	1.07	1.09	1.11	1.13	
27.	1.00	1.02	1.04	1.06	1.08	1.10	1.12	1.14	1.16	
26.	1.03	1.05	1.07	1.09	1.11	1.13	1.15	1.17	1.20	
25.	1.06	1.08	1.10	1.12	1.14	1.17	1.19	1.21	1.23	
24.	1.09	1.11	1.14	1.16	1.18	1.20	1.22	1.24	1.26	
23.	1.13	1.15	1.17	1.19	1.21	1.23	1.25	1.27	1.29	
22.	1.16	1.18	1.20	1.22	1.24	1.26	1.28	1.31	1.33	
21.	1.19	1.21	1.23	1.25	1.28	1.30	1.32	1.34	1.36	
20.	1.22	1.25	1.27	1.29	1.31	1.33	1.35	1.37	1.39	
19.	1.26	1.28	1.30	1.32	1.34	1.36	1.38	1.40	1.43	
18.	1.29	1.31	1.33	1.35	1.37	1.40	1.42	1.44	1.46	
17.	1.32	1.34	1.37	1.39	1.41	1.43	1.45	1.47	1.49	
16.	1.36	1.38	1.40	1.42	1.44	1.46	1.48	1.50	1.53	
15.	1.39	1.41	1.43	1.45	1.47	1.50	1.52	1.54	1.56	
14.	1.42	1.44	1.47	1.49	1.51	1.53	1.55	1.57	1.59	
13.	1.46	1.48	1.50	1.52	1.54	1.56	1.58	1.61	1.63	
12.	1.49	1.51	1.53	1.55	1.58	1.60	1.62	1.64	1.66	
11.	1.52	1.55	1.57	1.59	1.61	1.63	1.65	1.67	1.69	
10.	1.56	1.58	1.60	1.62	1.64	1.66	1.69	1.71	1.73	
9.	1.59	1.61	1.63	1.66	1.68	1.70	1.72	1.74	1.76	
8.	1.63	1.65	1.67	1.69	1.71	1.73	1.75	1.78	1.80	
7.	1.66	1.68	1.70	1.72	1.75	1.77	1.79	1.81	1.83	
6.	1.69	1.72	1.74	1.76	1.78	1.80	1.82	1.84	1.87	
5.	1.73	1.75	1.77	1.79	1.81	1.84	1.86	1.88	1.90	
4.	1.76	1.78	1.81	1.83	1.85	1.87	1.89	1.91	1.94	
3.	1.80	1.82	1.84	1.86	1.88	1.91	1.93	1.95	1.97	
2.	1.83	1.85	1.88	1.90	1.92	1.94	1.96	1.98	2.01	
1.	1.87	1.89	1.91	1.93	1.95	1.98	2.00	2.02	2.04	
0.	1.90	1.92	1.95	1.97	1.99	2.01	2.03	2.05	2.08	
-1.	1.94	1.96	1.98	2.00	2.02	2.05	2.07	2.09	2.11	
-2.	1.97	1.99	2.02	2.04	2.06	2.08	2.10	2.12	2.15	
-3.	2.01	2.03	2.05	2.07	2.09	2.12	2.14	2.16	2.18	
-4.	2.04	2.06	2.09	2.11	2.13	2.15	2.17	2.20	2.22	
-5.	2.08	2.10	2.12	2.14	2.17	2.19	2.21	2.23	2.25	
-6.	2.11	2.14	2.16	2.18	2.20	2.22	2.24	2.27	2.29	
-7.	2.15	2.17	2.19	2.21	2.24	2.26	2.28	2.30	2.32	
-8.	2.18	2.21	2.23	2.25	2.27	2.29	2.32	2.34	2.36	
-9.	2.22	2.24	2.26	2.29	2.31	2.33	2.35	2.37	2.40	
-10.	2.26	2.28	2.30	2.32	2.34	2.37	2.39	2.41	2.43	
-11.	2.29	2.31	2.34	2.36	2.38	2.40	2.43	2.45	2.47	
-12.	2.33	2.35	2.37	2.40	2.42	2.44	2.46	2.48	2.51	
-13.	2.37	2.39	2.41	2.43	2.45	2.48	2.50	2.52	2.54	
-14.	2.40	2.42	2.45	2.47	2.49	2.51	2.53	2.56	2.58	
-15.	2.44	2.46	2.48	2.51	2.53	2.55	2.57	2.59	2.62	
-16.	2.48	2.50	2.52	2.54	2.56	2.59	2.61	2.63	2.65	
-17.	2.51	2.53	2.56	2.58	2.60	2.62	2.65	2.67	2.69	
-18.	2.55	2.57	2.59	2.62	2.64	2.66	2.68	2.70	2.73	
-19.	2.59	2.61	2.63	2.65	2.68	2.70	2.72	2.74	2.76	
-20.	2.62	2.65	2.67	2.69	2.71	2.73	2.76	2.78	2.80	
	10.03	10.04	10.05	10.06	10.07	10.08	10.09	10.10	10.11	
	Heater Resistance (Ohm) ----->									

GO TO NEXT PAGE



12.56. BLADE DE-ICE CONTROLLER ADJUSTMENT - continued

TABLE II. TAIL ROTOR BLADE ADJUSTMENT CHARTS (cont)

Blade Temp. (°C)	Tail Rotor Adjustment Resistance (Kiloohm)									
	0.46	0.48	0.50	0.52	0.54	0.56	0.58	0.60	0.62	
50.	0.46	0.48	0.50	0.52	0.54	0.56	0.58	0.60	0.62	
49.	0.49	0.51	0.53	0.55	0.57	0.59	0.61	0.63	0.65	
48.	0.52	0.54	0.56	0.58	0.60	0.62	0.64	0.66	0.68	
47.	0.55	0.57	0.59	0.61	0.63	0.65	0.67	0.69	0.71	
46.	0.58	0.60	0.62	0.64	0.66	0.68	0.70	0.73	0.75	
45.	0.61	0.63	0.65	0.67	0.70	0.72	0.74	0.76	0.78	
44.	0.64	0.67	0.69	0.71	0.73	0.75	0.77	0.79	0.81	
43.	0.68	0.70	0.72	0.74	0.76	0.78	0.80	0.82	0.84	
42.	0.71	0.73	0.75	0.77	0.79	0.81	0.83	0.85	0.87	
41.	0.74	0.76	0.78	0.80	0.82	0.84	0.86	0.88	0.90	
40.	0.77	0.79	0.81	0.83	0.85	0.87	0.89	0.91	0.93	
39.	0.80	0.82	0.84	0.86	0.88	0.90	0.92	0.94	0.96	
38.	0.83	0.85	0.87	0.89	0.91	0.93	0.95	0.98	1.00	
37.	0.86	0.88	0.90	0.93	0.95	0.97	0.99	1.01	1.03	
36.	0.90	0.92	0.94	0.96	0.98	1.00	1.02	1.04	1.06	
35.	0.93	0.95	0.97	0.99	1.01	1.03	1.05	1.07	1.09	
34.	0.96	0.98	1.00	1.02	1.04	1.06	1.08	1.10	1.12	
33.	0.99	1.01	1.03	1.05	1.07	1.09	1.11	1.13	1.16	
32.	1.02	1.04	1.06	1.08	1.11	1.13	1.15	1.17	1.19	
31.	1.05	1.08	1.10	1.12	1.14	1.16	1.18	1.20	1.22	
30.	1.09	1.11	1.13	1.15	1.17	1.19	1.21	1.23	1.25	
29.	1.12	1.14	1.16	1.18	1.20	1.22	1.24	1.26	1.29	
28.	1.15	1.17	1.19	1.21	1.23	1.26	1.28	1.30	1.32	
27.	1.18	1.20	1.23	1.25	1.27	1.29	1.31	1.33	1.35	
26.	1.22	1.24	1.26	1.28	1.30	1.32	1.34	1.36	1.38	
25.	1.25	1.27	1.29	1.31	1.33	1.35	1.37	1.40	1.42	
24.	1.28	1.30	1.32	1.34	1.37	1.39	1.41	1.43	1.45	
23.	1.31	1.34	1.36	1.38	1.40	1.42	1.44	1.46	1.48	
22.	1.35	1.37	1.39	1.41	1.43	1.45	1.47	1.49	1.52	
21.	1.38	1.40	1.42	1.44	1.46	1.49	1.51	1.53	1.55	
20.	1.41	1.43	1.46	1.48	1.50	1.52	1.54	1.56	1.58	
19.	1.45	1.47	1.49	1.51	1.53	1.55	1.57	1.59	1.62	
18.	1.48	1.50	1.52	1.54	1.56	1.59	1.61	1.63	1.65	
17.	1.51	1.53	1.56	1.58	1.60	1.62	1.64	1.66	1.68	
16.	1.55	1.57	1.59	1.61	1.63	1.65	1.67	1.70	1.72	
15.	1.58	1.60	1.62	1.64	1.67	1.69	1.71	1.73	1.75	
14.	1.61	1.64	1.66	1.68	1.70	1.72	1.74	1.76	1.78	
13.	1.65	1.67	1.69	1.71	1.73	1.75	1.78	1.80	1.82	
12.	1.68	1.70	1.72	1.75	1.77	1.79	1.81	1.83	1.85	
11.	1.72	1.74	1.76	1.78	1.80	1.82	1.84	1.87	1.89	
10.	1.75	1.77	1.79	1.81	1.84	1.86	1.88	1.90	1.92	
9.	1.78	1.81	1.83	1.85	1.87	1.89	1.91	1.93	1.96	
8.	1.82	1.84	1.86	1.88	1.90	1.93	1.95	1.97	1.99	
7.	1.85	1.87	1.90	1.92	1.94	1.96	1.98	2.00	2.02	
6.	1.89	1.91	1.93	1.95	1.97	2.00	2.02	2.04	2.06	
5.	1.92	1.94	1.97	1.99	2.01	2.03	2.05	2.07	2.09	
4.	1.96	1.98	2.00	2.02	2.04	2.06	2.09	2.11	2.13	
3.	1.99	2.01	2.04	2.06	2.08	2.10	2.12	2.14	2.16	
2.	2.03	2.05	2.07	2.09	2.11	2.14	2.16	2.18	2.20	
1.	2.06	2.08	2.11	2.13	2.15	2.17	2.19	2.21	2.24	
0.	2.10	2.12	2.14	2.16	2.18	2.21	2.23	2.25	2.27	
-1.	2.13	2.15	2.18	2.20	2.22	2.24	2.26	2.28	2.31	
-2.	2.17	2.19	2.21	2.23	2.25	2.28	2.30	2.32	2.34	
-3.	2.20	2.23	2.25	2.27	2.29	2.31	2.33	2.36	2.38	
-4.	2.24	2.26	2.28	2.30	2.33	2.35	2.37	2.39	2.41	
-5.	2.27	2.30	2.32	2.34	2.36	2.38	2.41	2.43	2.45	
-6.	2.31	2.33	2.35	2.38	2.40	2.42	2.44	2.46	2.49	
-7.	2.35	2.37	2.39	2.41	2.43	2.46	2.48	2.50	2.52	
-8.	2.38	2.40	2.43	2.45	2.47	2.49	2.51	2.54	2.56	
-9.	2.42	2.44	2.46	2.48	2.51	2.53	2.55	2.57	2.59	
-10.	2.46	2.48	2.50	2.52	2.54	2.57	2.59	2.61	2.63	
-11.	2.49	2.51	2.54	2.56	2.58	2.60	2.62	2.65	2.67	
-12.	2.53	2.55	2.57	2.59	2.62	2.64	2.66	2.68	2.70	
-13.	2.56	2.59	2.61	2.63	2.65	2.68	2.70	2.72	2.74	
-14.	2.60	2.62	2.65	2.67	2.69	2.71	2.73	2.76	2.78	
-15.	2.64	2.66	2.68	2.70	2.73	2.75	2.77	2.79	2.82	
-16.	2.68	2.70	2.72	2.74	2.76	2.79	2.81	2.83	2.85	
-17.	2.71	2.73	2.76	2.78	2.80	2.82	2.85	2.87	2.89	
-18.	2.75	2.77	2.79	2.82	2.84	2.86	2.88	2.91	2.93	
-19.	2.79	2.81	2.83	2.85	2.88	2.90	2.92	2.94	2.97	
-20.	2.82	2.85	2.87	2.89	2.91	2.94	2.96	2.98	3.00	
	10.12	10.13	10.14	10.15	10.16	10.17	10.18	10.19	10.20	
	Heater Resistance (Ohm) ----->									

GO TO NEXT PAGE

12.56. BLADE DE-ICE CONTROLLER ADJUSTMENT - continued

TABLE II. TAIL ROTOR BLADE ADJUSTMENT CHARTS (cont)

Blade Temp. (°C)	Tail Rotor Adjustment Resistance (Kiloohm)									
	0.64	0.66	0.68	0.70	0.72	0.74	0.76	0.78	0.80	
50.	0.64	0.66	0.68	0.70	0.72	0.74	0.76	0.78	0.80	
49.	0.67	0.69	0.71	0.73	0.75	0.77	0.79	0.81	0.83	
48.	0.70	0.72	0.74	0.76	0.78	0.80	0.83	0.85	0.87	
47.	0.73	0.75	0.78	0.80	0.82	0.84	0.86	0.88	0.90	
46.	0.77	0.79	0.81	0.83	0.85	0.87	0.89	0.91	0.93	
45.	0.80	0.82	0.84	0.86	0.88	0.90	0.92	0.94	0.96	
44.	0.83	0.85	0.87	0.89	0.91	0.93	0.95	0.97	0.99	
43.	0.86	0.88	0.90	0.92	0.94	0.96	0.98	1.00	1.02	
42.	0.89	0.91	0.93	0.95	0.97	0.99	1.01	1.03	1.05	
41.	0.92	0.94	0.96	0.98	1.00	1.02	1.04	1.06	1.08	
40.	0.95	0.97	0.99	1.01	1.03	1.06	1.08	1.10	1.12	
39.	0.98	1.01	1.03	1.05	1.07	1.09	1.11	1.13	1.15	
38.	1.02	1.04	1.06	1.08	1.10	1.12	1.14	1.16	1.18	
37.	1.05	1.07	1.09	1.11	1.13	1.15	1.17	1.19	1.21	
36.	1.08	1.10	1.12	1.14	1.16	1.18	1.20	1.22	1.24	
35.	1.11	1.13	1.15	1.17	1.19	1.22	1.24	1.26	1.28	
34.	1.14	1.16	1.19	1.21	1.23	1.25	1.27	1.29	1.31	
33.	1.18	1.20	1.22	1.24	1.26	1.28	1.30	1.32	1.34	
32.	1.21	1.23	1.25	1.27	1.29	1.31	1.33	1.35	1.37	
31.	1.24	1.26	1.28	1.30	1.32	1.34	1.37	1.39	1.41	
30.	1.27	1.29	1.31	1.34	1.36	1.38	1.40	1.42	1.44	
29.	1.31	1.33	1.35	1.37	1.39	1.41	1.43	1.45	1.47	
28.	1.34	1.36	1.38	1.40	1.42	1.44	1.46	1.48	1.50	
27.	1.37	1.39	1.41	1.43	1.45	1.48	1.50	1.52	1.54	
26.	1.40	1.42	1.45	1.47	1.49	1.51	1.53	1.55	1.57	
25.	1.44	1.46	1.48	1.50	1.52	1.54	1.56	1.58	1.60	
24.	1.47	1.49	1.51	1.53	1.55	1.57	1.60	1.62	1.64	
23.	1.50	1.52	1.54	1.57	1.59	1.61	1.63	1.65	1.67	
22.	1.54	1.56	1.58	1.60	1.62	1.64	1.66	1.68	1.70	
21.	1.57	1.59	1.61	1.63	1.65	1.67	1.70	1.72	1.74	
20.	1.60	1.62	1.64	1.67	1.69	1.71	1.73	1.75	1.77	
19.	1.64	1.66	1.68	1.70	1.72	1.74	1.76	1.78	1.80	
18.	1.67	1.69	1.71	1.73	1.75	1.78	1.80	1.82	1.84	
17.	1.70	1.72	1.75	1.77	1.79	1.81	1.83	1.85	1.87	
16.	1.74	1.76	1.78	1.80	1.82	1.84	1.86	1.89	1.91	
15.	1.77	1.79	1.81	1.83	1.86	1.88	1.90	1.92	1.94	
14.	1.81	1.83	1.85	1.87	1.89	1.91	1.93	1.95	1.98	
13.	1.84	1.86	1.88	1.90	1.92	1.95	1.97	1.99	2.01	
12.	1.87	1.89	1.92	1.94	1.96	1.98	2.00	2.02	2.04	
11.	1.91	1.93	1.95	1.97	1.99	2.01	2.04	2.06	2.08	
10.	1.94	1.96	1.99	2.01	2.03	2.05	2.07	2.09	2.11	
9.	1.98	2.00	2.02	2.04	2.06	2.08	2.11	2.13	2.15	
8.	2.01	2.03	2.05	2.08	2.10	2.12	2.14	2.16	2.18	
7.	2.05	2.07	2.09	2.11	2.13	2.15	2.18	2.20	2.22	
6.	2.08	2.10	2.12	2.15	2.17	2.19	2.21	2.23	2.25	
5.	2.12	2.14	2.16	2.18	2.20	2.22	2.25	2.27	2.29	
4.	2.15	2.17	2.19	2.22	2.24	2.26	2.28	2.30	2.32	
3.	2.19	2.21	2.23	2.25	2.27	2.29	2.32	2.34	2.36	
2.	2.22	2.24	2.26	2.29	2.31	2.33	2.35	2.37	2.39	
1.	2.26	2.28	2.30	2.32	2.34	2.37	2.39	2.41	2.43	
0.	2.29	2.31	2.34	2.36	2.38	2.40	2.42	2.44	2.47	
-1.	2.33	2.35	2.37	2.39	2.41	2.44	2.46	2.48	2.50	
-2.	2.36	2.39	2.41	2.43	2.45	2.47	2.49	2.52	2.54	
-3.	2.40	2.42	2.44	2.46	2.49	2.51	2.53	2.55	2.57	
-4.	2.44	2.46	2.48	2.50	2.52	2.54	2.57	2.59	2.61	
-5.	2.47	2.49	2.52	2.54	2.56	2.58	2.60	2.62	2.65	
-6.	2.51	2.53	2.55	2.57	2.60	2.62	2.64	2.66	2.68	
-7.	2.54	2.57	2.59	2.61	2.63	2.65	2.68	2.70	2.72	
-8.	2.58	2.60	2.62	2.65	2.67	2.69	2.71	2.73	2.76	
-9.	2.62	2.64	2.66	2.68	2.70	2.73	2.75	2.77	2.79	
-10.	2.65	2.68	2.70	2.72	2.74	2.76	2.79	2.81	2.83	
-11.	2.69	2.71	2.73	2.76	2.78	2.80	2.82	2.84	2.87	
-12.	2.73	2.75	2.77	2.79	2.82	2.84	2.86	2.88	2.90	
-13.	2.76	2.79	2.81	2.83	2.85	2.87	2.90	2.92	2.94	
-14.	2.80	2.82	2.85	2.87	2.89	2.91	2.93	2.96	2.98	
-15.	2.84	2.86	2.88	2.90	2.93	2.95	2.97	2.99	3.02	
-16.	2.88	2.90	2.92	2.94	2.96	2.99	3.01	3.03	3.05	
-17.	2.91	2.94	2.96	2.98	3.00	3.02	3.05	3.07	3.09	
-18.	2.95	2.97	3.00	3.02	3.04	3.06	3.08	3.11	3.13	
-19.	2.99	3.01	3.03	3.06	3.08	3.10	3.12	3.14	3.17	
-20.	3.03	3.05	3.07	3.09	3.12	3.14	3.16	3.18	3.20	
	10.21	10.22	10.23	10.24	10.25	10.26	10.27	10.28	10.29	
	Heater Resistance (Ohm) ----->									

GO TO NEXT PAGE

12.56. BLADE DE-ICE CONTROLLER ADJUSTMENT - continued

TABLE II. TAIL ROTOR BLADE ADJUSTMENT CHARTS (cont)

Blade Temp. (°C)	Tail Rotor Adjustment Resistance (Kiloohm)									
	0.82	0.84	0.86	0.88	0.90	0.92	0.94	0.96	0.98	
50.	0.82	0.84	0.86	0.88	0.90	0.92	0.94	0.96	0.98	
49.	0.85	0.87	0.89	0.92	0.94	0.96	0.98	1.00	1.02	
48.	0.89	0.91	0.93	0.95	0.97	0.99	1.01	1.03	1.05	
47.	0.92	0.94	0.96	0.98	1.00	1.02	1.04	1.06	1.08	
46.	0.95	0.97	0.99	1.01	1.03	1.05	1.07	1.09	1.11	
45.	0.98	1.00	1.02	1.04	1.06	1.08	1.10	1.12	1.14	
44.	1.01	1.03	1.05	1.07	1.09	1.11	1.13	1.15	1.17	
43.	1.04	1.06	1.08	1.10	1.12	1.14	1.16	1.18	1.20	
42.	1.07	1.09	1.11	1.13	1.16	1.18	1.20	1.22	1.24	
41.	1.11	1.13	1.15	1.17	1.19	1.21	1.23	1.25	1.27	
40.	1.14	1.16	1.18	1.20	1.22	1.24	1.26	1.28	1.30	
39.	1.17	1.19	1.21	1.23	1.25	1.27	1.29	1.31	1.33	
38.	1.20	1.22	1.24	1.26	1.28	1.30	1.32	1.34	1.36	
37.	1.23	1.25	1.27	1.29	1.32	1.34	1.36	1.38	1.40	
36.	1.27	1.29	1.31	1.33	1.35	1.37	1.39	1.41	1.43	
35.	1.30	1.32	1.34	1.36	1.38	1.40	1.42	1.44	1.46	
34.	1.33	1.35	1.37	1.39	1.41	1.43	1.45	1.47	1.49	
33.	1.36	1.38	1.40	1.42	1.44	1.47	1.49	1.51	1.53	
32.	1.39	1.42	1.44	1.46	1.48	1.50	1.52	1.54	1.56	
31.	1.43	1.45	1.47	1.49	1.51	1.53	1.55	1.57	1.59	
30.	1.46	1.48	1.50	1.52	1.54	1.56	1.58	1.61	1.63	
29.	1.49	1.51	1.53	1.55	1.58	1.60	1.62	1.64	1.66	
28.	1.53	1.55	1.57	1.59	1.61	1.63	1.65	1.67	1.69	
27.	1.56	1.58	1.60	1.62	1.64	1.66	1.68	1.70	1.73	
26.	1.59	1.61	1.63	1.65	1.68	1.70	1.72	1.74	1.76	
25.	1.62	1.65	1.67	1.69	1.71	1.73	1.75	1.77	1.79	
24.	1.66	1.68	1.70	1.72	1.74	1.76	1.78	1.80	1.83	
23.	1.69	1.71	1.73	1.75	1.78	1.80	1.82	1.84	1.86	
22.	1.72	1.75	1.77	1.79	1.81	1.83	1.85	1.87	1.89	
21.	1.76	1.78	1.80	1.82	1.84	1.86	1.88	1.91	1.93	
20.	1.79	1.81	1.83	1.86	1.88	1.90	1.92	1.94	1.96	
19.	1.83	1.85	1.87	1.89	1.91	1.93	1.95	1.97	1.99	
18.	1.86	1.88	1.90	1.92	1.94	1.97	1.99	2.01	2.03	
17.	1.89	1.92	1.94	1.96	1.98	2.00	2.02	2.04	2.06	
16.	1.93	1.95	1.97	1.99	2.01	2.03	2.05	2.08	2.10	
15.	1.96	1.98	2.00	2.03	2.05	2.07	2.09	2.11	2.13	
14.	2.00	2.02	2.04	2.06	2.08	2.10	2.12	2.15	2.17	
13.	2.03	2.05	2.07	2.09	2.12	2.14	2.16	2.18	2.20	
12.	2.07	2.09	2.11	2.13	2.15	2.17	2.19	2.21	2.24	
11.	2.10	2.12	2.14	2.16	2.19	2.21	2.23	2.25	2.27	
10.	2.13	2.16	2.18	2.20	2.22	2.24	2.26	2.28	2.31	
9.	2.17	2.19	2.21	2.23	2.26	2.28	2.30	2.32	2.34	
8.	2.20	2.23	2.25	2.27	2.29	2.31	2.33	2.35	2.38	
7.	2.24	2.26	2.28	2.30	2.33	2.35	2.37	2.39	2.41	
6.	2.27	2.30	2.32	2.34	2.36	2.38	2.40	2.43	2.45	
5.	2.31	2.33	2.35	2.37	2.40	2.42	2.44	2.46	2.48	
4.	2.35	2.37	2.39	2.41	2.43	2.45	2.47	2.50	2.52	
3.	2.38	2.40	2.42	2.45	2.47	2.49	2.51	2.53	2.55	
2.	2.42	2.44	2.46	2.48	2.50	2.52	2.55	2.57	2.59	
1.	2.45	2.47	2.50	2.52	2.54	2.56	2.58	2.60	2.63	
0.	2.49	2.51	2.53	2.55	2.57	2.60	2.62	2.64	2.66	
-1.	2.52	2.55	2.57	2.59	2.61	2.63	2.65	2.68	2.70	
-2.	2.56	2.58	2.60	2.62	2.65	2.67	2.69	2.71	2.73	
-3.	2.60	2.62	2.64	2.66	2.68	2.70	2.73	2.75	2.77	
-4.	2.63	2.65	2.68	2.70	2.72	2.74	2.76	2.78	2.81	
-5.	2.67	2.69	2.71	2.73	2.76	2.78	2.80	2.82	2.84	
-6.	2.70	2.73	2.75	2.77	2.79	2.81	2.84	2.86	2.88	
-7.	2.74	2.76	2.79	2.81	2.83	2.85	2.87	2.89	2.92	
-8.	2.78	2.80	2.82	2.84	2.87	2.89	2.91	2.93	2.95	
-9.	2.81	2.84	2.86	2.88	2.90	2.92	2.95	2.97	2.99	
-10.	2.85	2.87	2.90	2.92	2.94	2.96	2.98	3.01	3.03	
-11.	2.89	2.91	2.93	2.95	2.98	3.00	3.02	3.04	3.07	
-12.	2.93	2.95	2.97	2.99	3.01	3.04	3.06	3.08	3.10	
-13.	2.96	2.99	3.01	3.03	3.05	3.07	3.10	3.12	3.14	
-14.	3.00	3.02	3.04	3.07	3.09	3.11	3.13	3.16	3.18	
-15.	3.04	3.06	3.08	3.10	3.13	3.15	3.17	3.19	3.22	
-16.	3.08	3.10	3.12	3.14	3.16	3.19	3.21	3.23	3.25	
-17.	3.11	3.14	3.16	3.18	3.20	3.22	3.25	3.27	3.29	
-18.	3.15	3.17	3.20	3.22	3.24	3.26	3.29	3.31	3.33	
-19.	3.19	3.21	3.23	3.26	3.28	3.30	3.32	3.35	3.37	
-20.	3.23	3.25	3.27	3.29	3.32	3.34	3.36	3.38	3.41	
	10.30	10.31	10.32	10.33	10.34	10.35	10.36	10.37	10.38	
	Heater Resistance (Ohm) ----->									

GO TO NEXT PAGE

12.56. BLADE DE-ICE CONTROLLER ADJUSTMENT - continued

TABLE II. TAIL ROTOR BLADE ADJUSTMENT CHARTS (cont)

Blade Temp. (°C)	Tail Rotor Adjustment Resistance (Kiloohm)									
	1.00	1.03	1.05	1.07	1.09	1.11	1.13	1.15	1.17	
50.	1.00	1.03	1.05	1.07	1.09	1.11	1.13	1.15	1.17	
49.	1.04	1.06	1.08	1.10	1.12	1.14	1.16	1.18	1.20	
48.	1.07	1.09	1.11	1.13	1.15	1.17	1.19	1.21	1.23	
47.	1.10	1.12	1.14	1.16	1.18	1.20	1.22	1.24	1.26	
46.	1.13	1.15	1.17	1.19	1.21	1.23	1.25	1.27	1.29	
45.	1.16	1.18	1.20	1.22	1.24	1.26	1.28	1.30	1.32	
44.	1.19	1.21	1.23	1.25	1.27	1.30	1.32	1.34	1.36	
43.	1.23	1.25	1.27	1.29	1.31	1.33	1.35	1.37	1.39	
42.	1.26	1.28	1.30	1.32	1.34	1.36	1.38	1.40	1.42	
41.	1.29	1.31	1.33	1.35	1.37	1.39	1.41	1.43	1.45	
40.	1.32	1.34	1.36	1.38	1.40	1.42	1.44	1.46	1.48	
39.	1.35	1.37	1.39	1.41	1.44	1.46	1.48	1.50	1.52	
38.	1.39	1.41	1.43	1.45	1.47	1.49	1.51	1.53	1.55	
37.	1.42	1.44	1.46	1.48	1.50	1.52	1.54	1.56	1.58	
36.	1.45	1.47	1.49	1.51	1.53	1.55	1.57	1.59	1.61	
35.	1.48	1.50	1.52	1.54	1.56	1.59	1.61	1.63	1.65	
34.	1.52	1.54	1.56	1.58	1.60	1.62	1.64	1.66	1.68	
33.	1.55	1.57	1.59	1.61	1.63	1.65	1.67	1.69	1.71	
32.	1.58	1.60	1.62	1.64	1.66	1.68	1.70	1.73	1.75	
31.	1.61	1.63	1.65	1.68	1.70	1.72	1.74	1.76	1.78	
30.	1.65	1.67	1.69	1.71	1.73	1.75	1.77	1.79	1.81	
29.	1.68	1.70	1.72	1.74	1.76	1.78	1.80	1.82	1.85	
28.	1.71	1.73	1.75	1.78	1.80	1.82	1.84	1.86	1.88	
27.	1.75	1.77	1.79	1.81	1.83	1.85	1.87	1.89	1.91	
26.	1.78	1.80	1.82	1.84	1.86	1.88	1.90	1.93	1.95	
25.	1.81	1.83	1.85	1.88	1.90	1.92	1.94	1.96	1.98	
24.	1.85	1.87	1.89	1.91	1.93	1.95	1.97	1.99	2.01	
23.	1.88	1.90	1.92	1.94	1.96	1.98	2.01	2.03	2.05	
22.	1.91	1.93	1.96	1.98	2.00	2.02	2.04	2.06	2.08	
21.	1.95	1.97	1.99	2.01	2.03	2.05	2.07	2.09	2.12	
20.	1.98	2.00	2.02	2.04	2.07	2.09	2.11	2.13	2.15	
19.	2.02	2.04	2.06	2.08	2.10	2.12	2.14	2.16	2.18	
18.	2.05	2.07	2.09	2.11	2.13	2.16	2.18	2.20	2.22	
17.	2.08	2.11	2.13	2.15	2.17	2.19	2.21	2.23	2.25	
16.	2.12	2.14	2.16	2.18	2.20	2.22	2.25	2.27	2.29	
15.	2.15	2.17	2.20	2.22	2.24	2.26	2.28	2.30	2.32	
14.	2.19	2.21	2.23	2.25	2.27	2.29	2.31	2.34	2.36	
13.	2.22	2.24	2.26	2.29	2.31	2.33	2.35	2.37	2.39	
12.	2.26	2.28	2.30	2.32	2.34	2.36	2.38	2.41	2.43	
11.	2.29	2.31	2.33	2.36	2.38	2.40	2.42	2.44	2.46	
10.	2.33	2.35	2.37	2.39	2.41	2.43	2.46	2.48	2.50	
9.	2.36	2.38	2.40	2.43	2.45	2.47	2.49	2.51	2.53	
8.	2.40	2.42	2.44	2.46	2.48	2.50	2.53	2.55	2.57	
7.	2.43	2.45	2.48	2.50	2.52	2.54	2.56	2.58	2.60	
6.	2.47	2.49	2.51	2.53	2.55	2.58	2.60	2.62	2.64	
5.	2.50	2.53	2.55	2.57	2.59	2.61	2.63	2.65	2.68	
4.	2.54	2.56	2.58	2.60	2.63	2.65	2.67	2.69	2.71	
3.	2.57	2.60	2.62	2.64	2.66	2.68	2.70	2.73	2.75	
2.	2.61	2.63	2.65	2.68	2.70	2.72	2.74	2.76	2.78	
1.	2.65	2.67	2.69	2.71	2.73	2.76	2.78	2.80	2.82	
0.	2.68	2.70	2.73	2.75	2.77	2.79	2.81	2.83	2.86	
-1.	2.72	2.74	2.76	2.78	2.81	2.83	2.85	2.87	2.89	
-2.	2.76	2.78	2.80	2.82	2.84	2.86	2.89	2.91	2.93	
-3.	2.79	2.81	2.84	2.86	2.88	2.90	2.92	2.94	2.97	
-4.	2.83	2.85	2.87	2.89	2.92	2.94	2.96	2.98	3.00	
-5.	2.87	2.89	2.91	2.93	2.95	2.97	3.00	3.02	3.04	
-6.	2.90	2.92	2.95	2.97	2.99	3.01	3.03	3.06	3.08	
-7.	2.94	2.96	2.98	3.00	3.03	3.05	3.07	3.09	3.11	
-8.	2.98	3.00	3.02	3.04	3.06	3.09	3.11	3.13	3.15	
-9.	3.01	3.03	3.06	3.08	3.10	3.12	3.14	3.17	3.19	
-10.	3.05	3.07	3.09	3.12	3.14	3.16	3.18	3.20	3.23	
-11.	3.09	3.11	3.13	3.15	3.18	3.20	3.22	3.24	3.26	
-12.	3.12	3.15	3.17	3.19	3.21	3.24	3.26	3.28	3.30	
-13.	3.16	3.18	3.21	3.23	3.25	3.27	3.30	3.32	3.34	
-14.	3.20	3.22	3.24	3.27	3.29	3.31	3.33	3.36	3.38	
-15.	3.24	3.26	3.28	3.30	3.33	3.35	3.37	3.39	3.42	
-16.	3.28	3.30	3.32	3.34	3.36	3.39	3.41	3.43	3.45	
-17.	3.31	3.34	3.36	3.38	3.40	3.43	3.45	3.47	3.49	
-18.	3.35	3.37	3.40	3.42	3.44	3.46	3.49	3.51	3.53	
-19.	3.39	3.41	3.44	3.46	3.48	3.50	3.52	3.55	3.57	
-20.	3.43	3.45	3.47	3.50	3.52	3.54	3.56	3.59	3.61	
	10.39	10.40	10.41	10.42	10.43	10.44	10.45	10.46	10.47	
	Heater Resistance (Ohm) ----->									

GO TO NEXT PAGE



12.56. BLADE DE-ICE CONTROLLER ADJUSTMENT - continued

TABLE II. TAIL ROTOR BLADE ADJUSTMENT CHARTS (cont)

Blade Temp. (°C)	Tail Rotor Adjustment Resistance (Kiloohm)									
	10.57	10.58	10.59	10.60	10.61	10.62	10.63	10.64	10.65	
50.	1.37	1.39	1.41	1.43	1.45	1.47	1.49	1.51	1.53	
49.	1.40	1.42	1.44	1.46	1.48	1.50	1.52	1.54	1.56	
48.	1.43	1.45	1.47	1.49	1.51	1.53	1.55	1.57	1.59	
47.	1.46	1.48	1.50	1.52	1.54	1.56	1.58	1.60	1.62	
46.	1.49	1.52	1.54	1.56	1.58	1.60	1.62	1.64	1.66	
45.	1.53	1.55	1.57	1.59	1.61	1.63	1.65	1.67	1.69	
44.	1.56	1.58	1.60	1.62	1.64	1.66	1.68	1.70	1.72	
43.	1.59	1.61	1.63	1.65	1.67	1.69	1.71	1.73	1.75	
42.	1.62	1.64	1.66	1.68	1.71	1.73	1.75	1.77	1.79	
41.	1.66	1.68	1.70	1.72	1.74	1.76	1.78	1.80	1.82	
40.	1.69	1.71	1.73	1.75	1.77	1.79	1.81	1.83	1.85	
39.	1.72	1.74	1.76	1.78	1.80	1.82	1.84	1.86	1.89	
38.	1.75	1.77	1.80	1.82	1.84	1.86	1.88	1.90	1.92	
37.	1.79	1.81	1.83	1.85	1.87	1.89	1.91	1.93	1.95	
36.	1.82	1.84	1.86	1.88	1.90	1.92	1.94	1.96	1.98	
35.	1.85	1.87	1.89	1.91	1.94	1.96	1.98	2.00	2.02	
34.	1.89	1.91	1.93	1.95	1.97	1.99	2.01	2.03	2.05	
33.	1.92	1.94	1.96	1.98	2.00	2.02	2.04	2.06	2.08	
32.	1.95	1.97	1.99	2.01	2.04	2.06	2.08	2.10	2.12	
31.	1.99	2.01	2.03	2.05	2.07	2.09	2.11	2.13	2.15	
30.	2.02	2.04	2.06	2.08	2.10	2.12	2.14	2.16	2.19	
29.	2.05	2.07	2.09	2.12	2.14	2.16	2.18	2.20	2.22	
28.	2.09	2.11	2.13	2.15	2.17	2.19	2.21	2.23	2.25	
27.	2.12	2.14	2.16	2.18	2.20	2.23	2.25	2.27	2.29	
26.	2.15	2.18	2.20	2.22	2.24	2.26	2.28	2.30	2.32	
25.	2.19	2.21	2.23	2.25	2.27	2.29	2.31	2.34	2.36	
24.	2.22	2.24	2.26	2.29	2.31	2.33	2.35	2.37	2.39	
23.	2.26	2.28	2.30	2.32	2.34	2.36	2.38	2.40	2.42	
22.	2.29	2.31	2.33	2.35	2.38	2.40	2.42	2.44	2.46	
21.	2.33	2.35	2.37	2.39	2.41	2.43	2.45	2.47	2.49	
20.	2.36	2.38	2.40	2.42	2.44	2.47	2.49	2.51	2.53	
19.	2.40	2.42	2.44	2.46	2.48	2.50	2.52	2.54	2.56	
18.	2.43	2.45	2.47	2.49	2.51	2.54	2.56	2.58	2.60	
17.	2.46	2.49	2.51	2.53	2.55	2.57	2.59	2.61	2.63	
16.	2.50	2.52	2.54	2.56	2.58	2.61	2.63	2.65	2.67	
15.	2.53	2.56	2.58	2.60	2.62	2.64	2.66	2.68	2.70	
14.	2.57	2.59	2.61	2.63	2.65	2.68	2.70	2.72	2.74	
13.	2.61	2.63	2.65	2.67	2.69	2.71	2.73	2.75	2.78	
12.	2.64	2.66	2.68	2.70	2.73	2.75	2.77	2.79	2.81	
11.	2.68	2.70	2.72	2.74	2.76	2.78	2.80	2.83	2.85	
10.	2.71	2.73	2.75	2.78	2.80	2.82	2.84	2.86	2.88	
9.	2.75	2.77	2.79	2.81	2.83	2.85	2.88	2.90	2.92	
8.	2.78	2.80	2.83	2.85	2.87	2.89	2.91	2.93	2.95	
7.	2.82	2.84	2.86	2.88	2.90	2.93	2.95	2.97	2.99	
6.	2.85	2.88	2.90	2.92	2.94	2.96	2.98	3.01	3.03	
5.	2.89	2.91	2.93	2.96	2.98	3.00	3.02	3.04	3.06	
4.	2.93	2.95	2.97	2.99	3.01	3.04	3.06	3.08	3.10	
3.	2.96	2.99	3.01	3.03	3.05	3.07	3.09	3.11	3.14	
2.	3.00	3.02	3.04	3.06	3.09	3.11	3.13	3.15	3.17	
1.	3.04	3.06	3.08	3.10	3.12	3.14	3.17	3.19	3.21	
0.	3.07	3.10	3.12	3.14	3.16	3.18	3.20	3.23	3.25	
-1.	3.11	3.13	3.15	3.18	3.20	3.22	3.24	3.26	3.28	
-2.	3.15	3.17	3.19	3.21	3.23	3.26	3.28	3.30	3.32	
-3.	3.18	3.21	3.23	3.25	3.27	3.29	3.31	3.34	3.36	
-4.	3.22	3.24	3.26	3.29	3.31	3.33	3.35	3.37	3.40	
-5.	3.26	3.28	3.30	3.32	3.35	3.37	3.39	3.41	3.43	
-6.	3.30	3.32	3.34	3.36	3.38	3.41	3.43	3.45	3.47	
-7.	3.33	3.36	3.38	3.40	3.42	3.44	3.46	3.49	3.51	
-8.	3.37	3.39	3.41	3.44	3.46	3.48	3.50	3.52	3.55	
-9.	3.41	3.43	3.45	3.47	3.50	3.52	3.54	3.56	3.58	
-10.	3.45	3.47	3.49	3.51	3.53	3.56	3.58	3.60	3.62	
-11.	3.48	3.51	3.53	3.55	3.57	3.59	3.62	3.64	3.66	
-12.	3.52	3.54	3.57	3.59	3.61	3.63	3.66	3.68	3.70	
-13.	3.56	3.58	3.61	3.63	3.65	3.67	3.69	3.72	3.74	
-14.	3.60	3.62	3.64	3.67	3.69	3.71	3.73	3.75	3.78	
-15.	3.64	3.66	3.68	3.70	3.73	3.75	3.77	3.79	3.82	
-16.	3.68	3.70	3.72	3.74	3.77	3.79	3.81	3.83	3.85	
-17.	3.71	3.74	3.76	3.78	3.80	3.83	3.85	3.87	3.89	
-18.	3.75	3.78	3.80	3.82	3.84	3.87	3.89	3.91	3.93	
-19.	3.79	3.81	3.84	3.86	3.88	3.90	3.93	3.95	3.97	
-20.	3.83	3.85	3.88	3.90	3.92	3.94	3.97	3.99	4.01	
	10.57	10.58	10.59	10.60	10.61	10.62	10.63	10.64	10.65	
	Heater Resistance (Ohm) ----->									

GO TO NEXT PAGE

12.56. BLADE DE-ICE CONTROLLER ADJUSTMENT - continued

TABLE II. TAIL ROTOR BLADE ADJUSTMENT CHARTS (cont)

Blade Temp. (°C)	Tail Rotor Adjustment Resistance (Kiloohm)									
50.	1.55	1.57	1.59	1.61	1.63	1.65	1.67	1.69	1.71	
49.	1.58	1.60	1.62	1.64	1.66	1.68	1.70	1.72	1.74	
48.	1.61	1.63	1.65	1.67	1.69	1.71	1.73	1.75	1.77	
47.	1.65	1.67	1.69	1.71	1.73	1.75	1.77	1.79	1.81	
46.	1.68	1.70	1.72	1.74	1.76	1.78	1.80	1.82	1.84	
45.	1.71	1.73	1.75	1.77	1.79	1.81	1.83	1.85	1.87	
44.	1.74	1.76	1.78	1.80	1.82	1.84	1.86	1.88	1.90	
43.	1.77	1.79	1.82	1.84	1.86	1.88	1.90	1.92	1.94	
42.	1.81	1.83	1.85	1.87	1.89	1.91	1.93	1.95	1.97	
41.	1.84	1.86	1.88	1.90	1.92	1.94	1.96	1.98	2.00	
40.	1.87	1.89	1.91	1.93	1.95	1.97	2.00	2.02	2.04	
39.	1.91	1.93	1.95	1.97	1.99	2.01	2.03	2.05	2.07	
38.	1.94	1.96	1.98	2.00	2.02	2.04	2.06	2.08	2.10	
37.	1.97	1.99	2.01	2.03	2.05	2.07	2.09	2.12	2.14	
36.	2.01	2.03	2.05	2.07	2.09	2.11	2.13	2.15	2.17	
35.	2.04	2.06	2.08	2.10	2.12	2.14	2.16	2.18	2.20	
34.	2.07	2.09	2.11	2.13	2.15	2.17	2.20	2.22	2.24	
33.	2.11	2.13	2.15	2.17	2.19	2.21	2.23	2.25	2.27	
32.	2.14	2.16	2.18	2.20	2.22	2.24	2.26	2.28	2.30	
31.	2.17	2.19	2.21	2.23	2.26	2.28	2.30	2.32	2.34	
30.	2.21	2.23	2.25	2.27	2.29	2.31	2.33	2.35	2.37	
29.	2.24	2.26	2.28	2.30	2.32	2.34	2.36	2.39	2.41	
28.	2.27	2.30	2.32	2.34	2.36	2.38	2.40	2.42	2.44	
27.	2.31	2.33	2.35	2.37	2.39	2.41	2.43	2.45	2.47	
26.	2.34	2.36	2.38	2.41	2.43	2.45	2.47	2.49	2.51	
25.	2.38	2.40	2.42	2.44	2.46	2.48	2.50	2.52	2.54	
24.	2.41	2.43	2.45	2.47	2.49	2.52	2.54	2.56	2.59	
23.	2.45	2.47	2.49	2.51	2.53	2.55	2.57	2.59	2.61	
22.	2.48	2.50	2.52	2.54	2.56	2.59	2.61	2.63	2.65	
21.	2.52	2.54	2.56	2.58	2.60	2.62	2.64	2.66	2.68	
20.	2.55	2.57	2.59	2.61	2.63	2.66	2.68	2.70	2.72	
19.	2.58	2.61	2.63	2.65	2.67	2.69	2.71	2.73	2.75	
18.	2.62	2.64	2.66	2.68	2.70	2.73	2.75	2.77	2.79	
17.	2.65	2.68	2.70	2.72	2.74	2.76	2.78	2.80	2.82	
16.	2.69	2.71	2.73	2.75	2.77	2.80	2.82	2.84	2.86	
15.	2.73	2.75	2.77	2.79	2.81	2.83	2.85	2.87	2.90	
14.	2.76	2.78	2.80	2.82	2.85	2.87	2.89	2.91	2.93	
13.	2.80	2.82	2.84	2.86	2.88	2.90	2.92	2.95	2.97	
12.	2.83	2.85	2.87	2.90	2.92	2.94	2.96	2.98	3.00	
11.	2.87	2.89	2.91	2.93	2.95	2.97	3.00	3.02	3.04	
10.	2.90	2.93	2.95	2.97	2.99	3.01	3.03	3.05	3.07	
9.	2.94	2.96	2.98	3.00	3.03	3.05	3.07	3.09	3.11	
8.	2.98	3.00	3.02	3.04	3.06	3.08	3.10	3.13	3.15	
7.	3.01	3.03	3.05	3.08	3.10	3.12	3.14	3.16	3.18	
6.	3.05	3.07	3.09	3.11	3.13	3.16	3.18	3.20	3.22	
5.	3.08	3.11	3.13	3.15	3.17	3.19	3.21	3.24	3.26	
4.	3.12	3.14	3.16	3.19	3.21	3.23	3.25	3.27	3.29	
3.	3.16	3.18	3.20	3.22	3.24	3.27	3.29	3.31	3.33	
2.	3.19	3.22	3.24	3.26	3.28	3.30	3.32	3.35	3.37	
1.	3.23	3.25	3.27	3.30	3.32	3.34	3.36	3.38	3.40	
0.	3.27	3.29	3.31	3.33	3.36	3.38	3.40	3.42	3.44	
-1.	3.31	3.33	3.35	3.37	3.39	3.41	3.44	3.46	3.48	
-2.	3.34	3.36	3.39	3.41	3.43	3.45	3.47	3.50	3.52	
-3.	3.38	3.40	3.42	3.45	3.47	3.49	3.51	3.53	3.55	
-4.	3.42	3.44	3.46	3.48	3.51	3.53	3.55	3.57	3.59	
-5.	3.46	3.48	3.50	3.52	3.54	3.56	3.59	3.61	3.63	
-6.	3.49	3.51	3.54	3.56	3.58	3.60	3.62	3.65	3.67	
-7.	3.53	3.55	3.57	3.60	3.62	3.64	3.66	3.68	3.71	
-8.	3.57	3.59	3.61	3.63	3.66	3.68	3.70	3.72	3.74	
-9.	3.61	3.63	3.65	3.67	3.69	3.72	3.74	3.76	3.78	
-10.	3.64	3.67	3.69	3.71	3.73	3.76	3.78	3.80	3.82	
-11.	3.68	3.71	3.73	3.75	3.77	3.79	3.82	3.84	3.86	
-12.	3.72	3.74	3.77	3.79	3.81	3.83	3.85	3.88	3.90	
-13.	3.76	3.78	3.80	3.83	3.85	3.87	3.89	3.91	3.94	
-14.	3.80	3.82	3.84	3.87	3.89	3.91	3.93	3.95	3.98	
-15.	3.84	3.86	3.88	3.90	3.93	3.95	3.97	3.99	4.02	
-16.	3.88	3.90	3.92	3.94	3.97	3.99	4.01	4.03	4.05	
-17.	3.92	3.94	3.96	3.98	4.00	4.03	4.05	4.07	4.09	
-18.	3.95	3.98	4.00	4.02	4.04	4.07	4.09	4.11	4.13	
-19.	3.99	4.02	4.04	4.06	4.08	4.11	4.13	4.15	4.17	
-20.	4.03	4.06	4.08	4.10	4.12	4.14	4.17	4.19	4.21	
	10.66	10.67	10.68	10.69	10.70	10.71	10.72	10.73	10.74	
	Heater Resistance (Ohm) ----->									

GO TO NEXT PAGE

12.56. BLADE DE-ICE CONTROLLER ADJUSTMENT - continued

TABLE II. TAIL ROTOR BLADE ADJUSTMENT CHARTS (cont)

Blade Temp. (°C)	Tail Rotor Adjustment Resistance (Kiloohm)									
	10.75	10.76	10.77	10.78	10.79	10.80	10.81	10.82	10.83	10.84
50.	1.73	1.75	1.77	1.79	1.81	1.83	1.85	1.87	1.89	
49.	1.76	1.78	1.80	1.82	1.84	1.86	1.88	1.90	1.92	
48.	1.79	1.81	1.84	1.86	1.88	1.90	1.92	1.94	1.96	
47.	1.83	1.85	1.87	1.89	1.91	1.93	1.95	1.97	1.99	
46.	1.86	1.88	1.90	1.92	1.94	1.96	1.98	2.00	2.02	
45.	1.89	1.91	1.93	1.95	1.97	1.99	2.01	2.03	2.05	
44.	1.92	1.95	1.97	1.99	2.01	2.03	2.05	2.07	2.09	
43.	1.96	1.98	2.00	2.02	2.04	2.06	2.08	2.10	2.12	
42.	1.99	2.01	2.03	2.05	2.07	2.09	2.11	2.13	2.15	
41.	2.02	2.04	2.06	2.08	2.11	2.13	2.15	2.17	2.19	
40.	2.06	2.08	2.10	2.12	2.14	2.16	2.18	2.20	2.22	
39.	2.09	2.11	2.13	2.15	2.17	2.19	2.21	2.23	2.25	
38.	2.12	2.14	2.16	2.18	2.21	2.23	2.25	2.27	2.29	
37.	2.16	2.18	2.20	2.22	2.24	2.26	2.28	2.30	2.32	
36.	2.19	2.21	2.23	2.25	2.27	2.29	2.31	2.33	2.35	
35.	2.22	2.24	2.26	2.29	2.31	2.33	2.35	2.37	2.39	
34.	2.26	2.28	2.30	2.32	2.34	2.36	2.38	2.40	2.42	
33.	2.29	2.31	2.33	2.35	2.37	2.39	2.41	2.44	2.46	
32.	2.32	2.35	2.37	2.39	2.41	2.43	2.45	2.47	2.49	
31.	2.36	2.38	2.40	2.42	2.44	2.46	2.48	2.50	2.52	
30.	2.39	2.41	2.43	2.46	2.48	2.50	2.52	2.54	2.56	
29.	2.43	2.45	2.47	2.49	2.51	2.53	2.55	2.57	2.59	
28.	2.46	2.48	2.50	2.52	2.54	2.57	2.59	2.61	2.63	
27.	2.50	2.52	2.54	2.56	2.58	2.60	2.62	2.64	2.66	
26.	2.53	2.55	2.57	2.59	2.61	2.63	2.66	2.68	2.70	
25.	2.56	2.59	2.61	2.63	2.65	2.67	2.69	2.71	2.73	
24.	2.60	2.62	2.64	2.66	2.68	2.70	2.73	2.75	2.77	
23.	2.63	2.66	2.68	2.70	2.72	2.74	2.76	2.78	2.80	
22.	2.67	2.69	2.71	2.73	2.75	2.77	2.80	2.82	2.84	
21.	2.70	2.73	2.75	2.77	2.79	2.81	2.83	2.85	2.87	
20.	2.74	2.76	2.78	2.80	2.82	2.84	2.87	2.89	2.91	
19.	2.77	2.80	2.82	2.84	2.86	2.88	2.90	2.92	2.94	
18.	2.81	2.83	2.85	2.87	2.89	2.92	2.94	2.96	2.98	
17.	2.85	2.87	2.89	2.91	2.93	2.95	2.97	2.99	3.01	
16.	2.88	2.90	2.92	2.94	2.97	2.99	3.01	3.03	3.05	
15.	2.92	2.94	2.96	2.98	3.00	3.02	3.04	3.06	3.09	
14.	2.95	2.97	2.99	3.02	3.04	3.06	3.08	3.10	3.12	
13.	2.99	3.01	3.03	3.05	3.07	3.09	3.12	3.14	3.16	
12.	3.02	3.05	3.07	3.09	3.11	3.13	3.15	3.17	3.19	
11.	3.06	3.08	3.10	3.12	3.15	3.17	3.19	3.21	3.23	
10.	3.10	3.12	3.14	3.16	3.18	3.20	3.22	3.25	3.27	
9.	3.13	3.15	3.18	3.20	3.22	3.24	3.26	3.28	3.30	
8.	3.17	3.19	3.21	3.23	3.25	3.28	3.30	3.32	3.34	
7.	3.21	3.23	3.25	3.27	3.29	3.31	3.33	3.36	3.38	
6.	3.24	3.26	3.28	3.31	3.33	3.35	3.37	3.39	3.41	
5.	3.28	3.30	3.32	3.34	3.36	3.39	3.41	3.43	3.45	
4.	3.32	3.34	3.36	3.38	3.40	3.42	3.44	3.47	3.49	
3.	3.35	3.37	3.40	3.42	3.44	3.46	3.48	3.50	3.53	
2.	3.39	3.41	3.43	3.45	3.48	3.50	3.52	3.54	3.56	
1.	3.43	3.45	3.47	3.49	3.51	3.53	3.56	3.58	3.60	
0.	3.46	3.49	3.51	3.53	3.55	3.57	3.59	3.62	3.64	
-1.	3.50	3.52	3.54	3.57	3.59	3.61	3.63	3.65	3.68	
-2.	3.54	3.56	3.58	3.60	3.63	3.65	3.67	3.69	3.71	
-3.	3.58	3.60	3.62	3.64	3.66	3.69	3.71	3.73	3.75	
-4.	3.61	3.64	3.66	3.68	3.70	3.72	3.75	3.77	3.79	
-5.	3.65	3.67	3.70	3.72	3.74	3.76	3.78	3.81	3.83	
-6.	3.69	3.71	3.73	3.76	3.78	3.80	3.82	3.84	3.87	
-7.	3.73	3.75	3.77	3.79	3.82	3.84	3.86	3.88	3.90	
-8.	3.77	3.79	3.81	3.83	3.85	3.88	3.90	3.92	3.94	
-9.	3.80	3.83	3.85	3.87	3.89	3.91	3.94	3.96	3.98	
-10.	3.84	3.87	3.89	3.91	3.93	3.95	3.98	4.00	4.02	
-11.	3.88	3.90	3.93	3.95	3.97	3.99	4.01	4.04	4.06	
-12.	3.92	3.94	3.96	3.99	4.01	4.03	4.05	4.08	4.10	
-13.	3.96	3.98	4.00	4.03	4.05	4.07	4.09	4.11	4.14	
-14.	4.00	4.02	4.04	4.06	4.09	4.11	4.13	4.15	4.18	
-15.	4.04	4.06	4.08	4.10	4.13	4.15	4.17	4.19	4.21	
-16.	4.08	4.10	4.12	4.14	4.17	4.19	4.21	4.23	4.25	
-17.	4.12	4.14	4.16	4.18	4.20	4.23	4.25	4.27	4.29	
-18.	4.16	4.18	4.20	4.22	4.24	4.27	4.29	4.31	4.33	
-19.	4.19	4.22	4.24	4.26	4.28	4.31	4.33	4.35	4.37	
-20.	4.23	4.26	4.28	4.30	4.32	4.35	4.37	4.39	4.41	

Heater Resistance (Ohm) ----->

GO TO NEXT PAGE



12.56. BLADE DE-ICE CONTROLLER ADJUSTMENT - continued

TABLE II. TAIL ROTOR BLADE ADJUSTMENT CHARTS (cont)

Blade Temp. (°C)	Tail Rotor Adjustment Resistance (Kiloohm)									
	1.91	1.93	1.95	1.97	1.99	2.01	2.03	2.05	2.07	
50.	1.91	1.93	1.95	1.97	1.99	2.01	2.03	2.05	2.07	
49.	1.94	1.96	1.98	2.00	2.02	2.04	2.06	2.09	2.11	
48.	1.98	2.00	2.02	2.04	2.06	2.08	2.10	2.12	2.14	
47.	2.01	2.03	2.05	2.07	2.09	2.11	2.13	2.15	2.17	
46.	2.04	2.06	2.08	2.10	2.12	2.14	2.16	2.18	2.20	
45.	2.07	2.10	2.12	2.14	2.16	2.18	2.20	2.22	2.24	
44.	2.11	2.13	2.15	2.17	2.19	2.21	2.23	2.25	2.27	
43.	2.14	2.16	2.18	2.20	2.22	2.24	2.26	2.28	2.30	
42.	2.17	2.19	2.21	2.24	2.26	2.28	2.30	2.32	2.34	
41.	2.21	2.23	2.25	2.27	2.29	2.31	2.33	2.35	2.37	
40.	2.24	2.26	2.28	2.30	2.32	2.34	2.36	2.38	2.40	
39.	2.27	2.29	2.31	2.34	2.36	2.38	2.40	2.42	2.44	
38.	2.31	2.33	2.35	2.37	2.39	2.41	2.43	2.45	2.47	
37.	2.34	2.36	2.38	2.40	2.42	2.44	2.46	2.48	2.51	
36.	2.38	2.40	2.42	2.44	2.46	2.48	2.50	2.52	2.54	
35.	2.41	2.43	2.45	2.47	2.49	2.51	2.53	2.55	2.57	
34.	2.44	2.46	2.48	2.50	2.53	2.55	2.57	2.59	2.61	
33.	2.48	2.50	2.52	2.54	2.56	2.58	2.60	2.62	2.64	
32.	2.51	2.53	2.55	2.57	2.59	2.61	2.64	2.66	2.68	
31.	2.55	2.57	2.59	2.61	2.63	2.65	2.67	2.69	2.71	
30.	2.58	2.60	2.62	2.64	2.66	2.68	2.70	2.72	2.75	
29.	2.61	2.63	2.66	2.68	2.70	2.72	2.74	2.76	2.78	
28.	2.65	2.67	2.69	2.71	2.73	2.75	2.77	2.79	2.81	
27.	2.68	2.70	2.72	2.75	2.77	2.79	2.81	2.83	2.85	
26.	2.72	2.74	2.76	2.78	2.80	2.82	2.84	2.86	2.88	
25.	2.75	2.77	2.79	2.82	2.84	2.86	2.88	2.90	2.92	
24.	2.79	2.81	2.83	2.85	2.87	2.89	2.91	2.93	2.96	
23.	2.82	2.84	2.86	2.89	2.91	2.93	2.95	2.97	2.99	
22.	2.86	2.88	2.90	2.92	2.94	2.96	2.98	3.00	3.03	
21.	2.89	2.91	2.94	2.96	2.98	3.00	3.02	3.04	3.06	
20.	2.93	2.95	2.97	2.99	3.01	3.03	3.05	3.08	3.10	
19.	2.96	2.99	3.01	3.03	3.05	3.07	3.09	3.11	3.13	
18.	3.00	3.02	3.04	3.06	3.08	3.11	3.13	3.15	3.17	
17.	3.04	3.06	3.08	3.10	3.12	3.14	3.16	3.18	3.20	
16.	3.07	3.09	3.11	3.13	3.16	3.18	3.20	3.22	3.24	
15.	3.11	3.13	3.15	3.17	3.19	3.21	3.23	3.26	3.28	
14.	3.14	3.16	3.19	3.21	3.23	3.25	3.27	3.29	3.31	
13.	3.18	3.20	3.22	3.24	3.26	3.29	3.31	3.33	3.35	
12.	3.22	3.24	3.26	3.28	3.30	3.32	3.34	3.36	3.39	
11.	3.25	3.27	3.29	3.32	3.34	3.36	3.38	3.40	3.42	
10.	3.29	3.31	3.33	3.35	3.37	3.40	3.42	3.44	3.46	
9.	3.32	3.35	3.37	3.39	3.41	3.43	3.45	3.47	3.50	
8.	3.36	3.38	3.40	3.43	3.45	3.47	3.49	3.51	3.53	
7.	3.40	3.42	3.44	3.46	3.48	3.51	3.53	3.55	3.57	
6.	3.44	3.46	3.48	3.50	3.52	3.54	3.56	3.59	3.61	
5.	3.47	3.49	3.52	3.54	3.56	3.58	3.60	3.62	3.64	
4.	3.51	3.53	3.55	3.57	3.60	3.62	3.64	3.66	3.68	
3.	3.55	3.57	3.59	3.61	3.63	3.65	3.68	3.70	3.72	
2.	3.58	3.61	3.63	3.65	3.67	3.69	3.71	3.74	3.76	
1.	3.62	3.64	3.66	3.69	3.71	3.73	3.75	3.77	3.79	
0.	3.66	3.68	3.70	3.72	3.75	3.77	3.79	3.81	3.83	
-1.	3.70	3.72	3.74	3.76	3.78	3.81	3.83	3.85	3.87	
-2.	3.73	3.76	3.78	3.80	3.82	3.84	3.87	3.89	3.91	
-3.	3.77	3.79	3.82	3.84	3.86	3.88	3.90	3.93	3.95	
-4.	3.81	3.83	3.85	3.88	3.90	3.92	3.94	3.96	3.99	
-5.	3.85	3.87	3.89	3.91	3.94	3.96	3.98	4.00	4.02	
-6.	3.89	3.91	3.93	3.95	3.97	4.00	4.02	4.04	4.06	
-7.	3.93	3.95	3.97	3.99	4.01	4.04	4.06	4.08	4.10	
-8.	3.96	3.99	4.01	4.03	4.05	4.07	4.10	4.12	4.14	
-9.	4.00	4.02	4.05	4.07	4.09	4.11	4.13	4.16	4.18	
-10.	4.04	4.06	4.09	4.11	4.13	4.15	4.17	4.20	4.22	
-11.	4.08	4.10	4.12	4.15	4.17	4.19	4.21	4.23	4.26	
-12.	4.12	4.14	4.16	4.19	4.21	4.23	4.25	4.27	4.30	
-13.	4.16	4.18	4.20	4.22	4.25	4.27	4.29	4.31	4.34	
-14.	4.20	4.22	4.24	4.26	4.29	4.31	4.33	4.35	4.38	
-15.	4.24	4.26	4.28	4.30	4.33	4.35	4.37	4.39	4.41	
-16.	4.28	4.30	4.32	4.34	4.37	4.39	4.41	4.43	4.45	
-17.	4.32	4.34	4.36	4.38	4.41	4.43	4.45	4.47	4.49	
-18.	4.36	4.38	4.40	4.42	4.45	4.47	4.49	4.51	4.53	
-19.	4.40	4.42	4.44	4.46	4.49	4.51	4.53	4.55	4.57	
-20.	4.44	4.46	4.48	4.50	4.53	4.55	4.57	4.59	4.62	
	10.84	10.85	10.86	10.87	10.88	10.89	10.90	10.91	10.92	
	Heater Resistance (Ohm) ----->									

GO TO NEXT PAGE

12.56. BLADE DE-ICE CONTROLLER ADJUSTMENT - continued

TABLE II. TAIL ROTOR BLADE ADJUSTMENT CHARTS (cont)

Blade Temp. (°C)	Tail Rotor Adjustment Resistance (Kiloohm)								
	2.09	2.11	2.13	2.15	2.17	2.19	2.21	2.23	2.25
50.	2.09	2.11	2.13	2.15	2.17	2.19	2.21	2.23	2.25
49.	2.13	2.15	2.17	2.19	2.21	2.23	2.25	2.27	2.29
48.	2.16	2.18	2.20	2.22	2.24	2.26	2.28	2.30	2.32
47.	2.19	2.21	2.23	2.25	2.27	2.29	2.31	2.33	2.35
46.	2.22	2.24	2.26	2.29	2.31	2.33	2.35	2.37	2.39
45.	2.26	2.28	2.30	2.32	2.34	2.36	2.38	2.40	2.42
44.	2.29	2.31	2.33	2.35	2.37	2.39	2.41	2.43	2.45
43.	2.32	2.34	2.36	2.38	2.41	2.43	2.45	2.47	2.49
42.	2.36	2.38	2.40	2.42	2.44	2.46	2.48	2.50	2.52
41.	2.39	2.41	2.43	2.45	2.47	2.49	2.51	2.53	2.55
40.	2.42	2.44	2.47	2.49	2.51	2.53	2.55	2.57	2.59
39.	2.46	2.48	2.50	2.52	2.54	2.56	2.58	2.60	2.62
38.	2.49	2.51	2.53	2.55	2.57	2.59	2.62	2.64	2.66
37.	2.53	2.55	2.57	2.59	2.61	2.63	2.65	2.67	2.69
36.	2.56	2.58	2.60	2.62	2.64	2.66	2.68	2.70	2.72
35.	2.59	2.61	2.64	2.66	2.68	2.70	2.72	2.74	2.76
34.	2.63	2.65	2.67	2.69	2.71	2.73	2.75	2.77	2.79
33.	2.66	2.68	2.70	2.72	2.75	2.77	2.79	2.81	2.83
32.	2.70	2.72	2.74	2.76	2.78	2.80	2.82	2.84	2.86
31.	2.73	2.75	2.77	2.79	2.81	2.84	2.86	2.88	2.90
30.	2.77	2.79	2.81	2.83	2.85	2.87	2.89	2.91	2.93
29.	2.80	2.82	2.84	2.86	2.88	2.90	2.93	2.95	2.97
28.	2.84	2.86	2.88	2.90	2.92	2.94	2.96	2.98	3.00
27.	2.87	2.89	2.91	2.93	2.95	2.97	3.00	3.02	3.04
26.	2.91	2.93	2.95	2.97	2.99	3.01	3.03	3.05	3.07
25.	2.94	2.96	2.98	3.00	3.02	3.05	3.07	3.09	3.11
24.	2.98	3.00	3.02	3.04	3.06	3.08	3.10	3.12	3.14
23.	3.01	3.03	3.05	3.07	3.10	3.12	3.14	3.16	3.18
22.	3.05	3.07	3.09	3.11	3.13	3.15	3.17	3.19	3.21
21.	3.08	3.10	3.12	3.15	3.17	3.19	3.21	3.23	3.25
20.	3.12	3.14	3.16	3.18	3.20	3.22	3.24	3.27	3.29
19.	3.15	3.17	3.20	3.22	3.24	3.26	3.28	3.30	3.32
18.	3.19	3.21	3.23	3.25	3.27	3.30	3.32	3.34	3.36
17.	3.23	3.25	3.27	3.29	3.31	3.33	3.35	3.37	3.39
16.	3.26	3.28	3.30	3.33	3.35	3.37	3.39	3.41	3.43
15.	3.30	3.32	3.34	3.36	3.38	3.40	3.43	3.45	3.47
14.	3.33	3.36	3.38	3.40	3.42	3.44	3.46	3.48	3.50
13.	3.37	3.39	3.41	3.43	3.46	3.48	3.50	3.52	3.54
12.	3.41	3.43	3.45	3.47	3.49	3.51	3.54	3.56	3.58
11.	3.44	3.47	3.49	3.51	3.53	3.55	3.57	3.59	3.61
10.	3.48	3.50	3.52	3.54	3.57	3.59	3.61	3.63	3.65
9.	3.52	3.54	3.56	3.58	3.60	3.62	3.65	3.67	3.69
8.	3.55	3.58	3.60	3.62	3.64	3.66	3.68	3.70	3.73
7.	3.59	3.61	3.63	3.66	3.68	3.70	3.72	3.74	3.76
6.	3.63	3.65	3.67	3.69	3.71	3.74	3.76	3.78	3.80
5.	3.67	3.69	3.71	3.73	3.75	3.77	3.80	3.82	3.84
4.	3.70	3.73	3.75	3.77	3.79	3.81	3.83	3.85	3.88
3.	3.74	3.76	3.78	3.81	3.83	3.85	3.87	3.89	3.91
2.	3.78	3.80	3.82	3.84	3.87	3.89	3.91	3.93	3.95
1.	3.82	3.84	3.86	3.88	3.90	3.92	3.95	3.97	3.99
0.	3.85	3.88	3.90	3.92	3.94	3.96	3.98	4.01	4.03
-1.	3.89	3.91	3.94	3.96	3.98	4.00	4.02	4.04	4.07
-2.	3.93	3.95	3.97	4.00	4.02	4.04	4.06	4.08	4.10
-3.	3.97	3.99	4.01	4.03	4.06	4.08	4.10	4.12	4.14
-4.	4.01	4.03	4.05	4.07	4.09	4.12	4.14	4.16	4.18
-5.	4.05	4.07	4.09	4.11	4.13	4.15	4.18	4.20	4.22
-6.	4.08	4.11	4.13	4.15	4.17	4.19	4.22	4.24	4.26
-7.	4.12	4.14	4.17	4.19	4.21	4.23	4.25	4.28	4.30
-8.	4.16	4.18	4.21	4.23	4.25	4.27	4.29	4.32	4.34
-9.	4.20	4.22	4.24	4.27	4.29	4.31	4.33	4.35	4.38
-10.	4.24	4.26	4.28	4.31	4.33	4.35	4.37	4.39	4.42
-11.	4.28	4.30	4.32	4.35	4.37	4.39	4.41	4.43	4.46
-12.	4.32	4.34	4.36	4.38	4.41	4.43	4.45	4.47	4.50
-13.	4.36	4.38	4.40	4.42	4.45	4.47	4.49	4.51	4.53
-14.	4.40	4.42	4.44	4.46	4.49	4.51	4.53	4.55	4.57
-15.	4.44	4.46	4.48	4.50	4.53	4.55	4.57	4.59	4.61
-16.	4.48	4.50	4.52	4.54	4.57	4.59	4.61	4.63	4.65
-17.	4.52	4.54	4.56	4.58	4.61	4.63	4.65	4.67	4.69
-18.	4.56	4.58	4.60	4.62	4.65	4.67	4.69	4.71	4.74
-19.	4.60	4.62	4.64	4.66	4.69	4.71	4.73	4.75	4.78
-20.	4.64	4.66	4.68	4.70	4.73	4.75	4.77	4.79	4.82
	10.93	10.94	10.95	10.96	10.97	10.98	10.99	11.00	11.01
	Heater Resistance (Ohm) ----->								

GO TO NEXT PAGE

12.56. BLADE DE-ICE CONTROLLER ADJUSTMENT - continued

TABLE II. TAIL ROTOR BLADE ADJUSTMENT CHARTS (cont)

Blade Temp. (°C)	Tail Rotor Adjustment Resistance (Kiloohm)								
	11.02	11.03	11.04	11.05	11.06	11.07	11.08	11.09	11.10
50.	2.27	2.29	2.31	2.33	2.35	2.37	2.39	2.41	2.44
49.	2.31	2.33	2.35	2.37	2.39	2.41	2.43	2.45	2.47
48.	2.34	2.36	2.38	2.40	2.42	2.44	2.46	2.48	2.50
47.	2.37	2.39	2.41	2.43	2.45	2.47	2.49	2.51	2.54
46.	2.41	2.43	2.45	2.47	2.49	2.51	2.53	2.55	2.57
45.	2.44	2.46	2.48	2.50	2.52	2.54	2.56	2.58	2.60
44.	2.47	2.49	2.51	2.53	2.55	2.58	2.60	2.62	2.64
43.	2.51	2.53	2.55	2.57	2.59	2.61	2.63	2.65	2.67
42.	2.54	2.56	2.58	2.60	2.62	2.64	2.66	2.68	2.70
41.	2.57	2.59	2.62	2.64	2.66	2.68	2.70	2.72	2.74
40.	2.61	2.63	2.65	2.67	2.69	2.71	2.73	2.75	2.77
39.	2.64	2.66	2.68	2.70	2.72	2.74	2.77	2.79	2.81
38.	2.68	2.70	2.72	2.74	2.76	2.78	2.80	2.82	2.84
37.	2.71	2.73	2.75	2.77	2.79	2.81	2.83	2.85	2.87
36.	2.74	2.77	2.79	2.81	2.83	2.85	2.87	2.89	2.91
35.	2.78	2.80	2.82	2.84	2.86	2.88	2.90	2.92	2.94
34.	2.81	2.83	2.86	2.88	2.90	2.92	2.94	2.96	2.98
33.	2.85	2.87	2.89	2.91	2.93	2.95	2.97	2.99	3.01
32.	2.88	2.90	2.92	2.95	2.97	2.99	3.01	3.03	3.05
31.	2.92	2.94	2.96	2.98	3.00	3.02	3.04	3.06	3.08
30.	2.95	2.97	2.99	3.02	3.04	3.06	3.08	3.10	3.12
29.	2.99	3.01	3.03	3.05	3.07	3.09	3.11	3.13	3.15
28.	3.02	3.04	3.06	3.09	3.11	3.13	3.15	3.17	3.19
27.	3.06	3.08	3.10	3.12	3.14	3.16	3.18	3.20	3.22
26.	3.09	3.11	3.14	3.16	3.18	3.20	3.22	3.24	3.26
25.	3.13	3.15	3.17	3.19	3.21	3.23	3.25	3.28	3.30
24.	3.16	3.19	3.21	3.23	3.25	3.27	3.29	3.31	3.33
23.	3.20	3.22	3.24	3.26	3.28	3.30	3.33	3.35	3.37
22.	3.24	3.26	3.28	3.30	3.32	3.34	3.36	3.38	3.40
21.	3.27	3.29	3.31	3.33	3.36	3.38	3.40	3.42	3.44
20.	3.31	3.33	3.35	3.37	3.39	3.41	3.43	3.45	3.48
19.	3.34	3.36	3.39	3.41	3.43	3.45	3.47	3.49	3.51
18.	3.38	3.40	3.42	3.44	3.46	3.49	3.51	3.53	3.55
17.	3.42	3.44	3.46	3.48	3.50	3.52	3.54	3.56	3.59
16.	3.45	3.47	3.49	3.52	3.54	3.56	3.58	3.60	3.62
15.	3.49	3.51	3.53	3.55	3.57	3.59	3.62	3.64	3.66
14.	3.53	3.55	3.57	3.59	3.61	3.63	3.65	3.67	3.70
13.	3.56	3.58	3.60	3.63	3.65	3.67	3.69	3.71	3.73
12.	3.60	3.62	3.64	3.66	3.68	3.71	3.73	3.75	3.77
11.	3.64	3.66	3.68	3.70	3.72	3.74	3.76	3.79	3.81
10.	3.67	3.69	3.72	3.74	3.76	3.78	3.80	3.82	3.84
9.	3.71	3.73	3.75	3.77	3.80	3.82	3.84	3.86	3.88
8.	3.75	3.77	3.79	3.81	3.83	3.85	3.88	3.90	3.92
7.	3.78	3.81	3.83	3.85	3.87	3.89	3.91	3.93	3.96
6.	3.82	3.84	3.87	3.89	3.91	3.93	3.95	3.97	3.99
5.	3.86	3.88	3.90	3.92	3.95	3.97	3.99	4.01	4.03
4.	3.90	3.92	3.94	3.96	3.98	4.01	4.03	4.05	4.07
3.	3.94	3.96	3.98	4.00	4.02	4.04	4.06	4.09	4.11
2.	3.97	3.99	4.02	4.04	4.06	4.08	4.10	4.12	4.15
1.	4.01	4.03	4.05	4.08	4.10	4.12	4.14	4.16	4.18
0.	4.05	4.07	4.09	4.11	4.14	4.16	4.18	4.20	4.22
-1.	4.09	4.11	4.13	4.15	4.17	4.20	4.22	4.24	4.26
-2.	4.13	4.15	4.17	4.19	4.21	4.24	4.26	4.28	4.30
-3.	4.16	4.19	4.21	4.23	4.25	4.27	4.30	4.32	4.34
-4.	4.20	4.23	4.25	4.27	4.29	4.31	4.33	4.36	4.38
-5.	4.24	4.26	4.29	4.31	4.33	4.35	4.37	4.40	4.42
-6.	4.28	4.30	4.32	4.35	4.37	4.39	4.41	4.43	4.46
-7.	4.32	4.34	4.36	4.39	4.41	4.43	4.45	4.47	4.50
-8.	4.36	4.38	4.40	4.43	4.45	4.47	4.49	4.51	4.54
-9.	4.40	4.42	4.44	4.46	4.49	4.51	4.53	4.55	4.57
-10.	4.44	4.46	4.48	4.50	4.53	4.55	4.57	4.59	4.61
-11.	4.48	4.50	4.52	4.54	4.57	4.59	4.61	4.63	4.65
-12.	4.52	4.54	4.56	4.58	4.61	4.63	4.65	4.67	4.69
-13.	4.56	4.58	4.60	4.62	4.65	4.67	4.69	4.71	4.73
-14.	4.60	4.62	4.64	4.66	4.69	4.71	4.73	4.75	4.77
-15.	4.64	4.66	4.68	4.70	4.73	4.75	4.77	4.79	4.81
-16.	4.68	4.70	4.72	4.74	4.77	4.79	4.81	4.83	4.85
-17.	4.72	4.74	4.76	4.78	4.81	4.83	4.85	4.87	4.90
-18.	4.76	4.78	4.80	4.82	4.85	4.87	4.89	4.91	4.94
-19.	4.80	4.82	4.84	4.87	4.89	4.91	4.93	4.95	4.98
-20.	4.84	4.86	4.88	4.91	4.93	4.95	4.97	5.00	
	11.02	11.03	11.04	11.05	11.06	11.07	11.08	11.09	11.10
	Heater Resistance (Ohm) ----->								

GO TO NEXT PAGE

12.56. BLADE DE-ICE CONTROLLER ADJUSTMENT - continued

TABLE II. TAIL ROTOR BLADE ADJUSTMENT CHARTS (cont)

Blade Temp. (°C)	Tail Rotor Adjustment Resistance (Kiloohm)								
	2.46	2.48	2.50	2.52	2.54	2.56	2.58	2.60	2.62
50.	2.46	2.48	2.50	2.52	2.54	2.56	2.58	2.60	2.62
49.	2.49	2.51	2.53	2.55	2.57	2.59	2.61	2.63	2.65
48.	2.52	2.54	2.56	2.58	2.60	2.62	2.64	2.66	2.68
47.	2.56	2.58	2.60	2.62	2.64	2.66	2.68	2.70	2.72
46.	2.59	2.61	2.63	2.65	2.67	2.69	2.71	2.73	2.75
45.	2.62	2.64	2.66	2.68	2.70	2.72	2.74	2.76	2.78
44.	2.66	2.68	2.70	2.72	2.74	2.76	2.78	2.80	2.82
43.	2.69	2.71	2.73	2.75	2.77	2.79	2.81	2.83	2.85
42.	2.72	2.74	2.76	2.79	2.81	2.83	2.85	2.87	2.89
41.	2.76	2.78	2.80	2.82	2.84	2.86	2.88	2.90	2.92
40.	2.79	2.81	2.83	2.85	2.87	2.89	2.91	2.94	2.96
39.	2.83	2.85	2.87	2.89	2.91	2.93	2.95	2.97	2.99
38.	2.86	2.88	2.90	2.92	2.94	2.96	2.98	3.00	3.02
37.	2.90	2.92	2.94	2.96	2.98	3.00	3.02	3.04	3.06
36.	2.93	2.95	2.97	2.99	3.01	3.03	3.05	3.07	3.09
35.	2.96	2.99	3.01	3.03	3.05	3.07	3.09	3.11	3.13
34.	3.00	3.02	3.04	3.06	3.08	3.10	3.12	3.14	3.16
33.	3.03	3.05	3.08	3.10	3.12	3.14	3.16	3.18	3.20
32.	3.07	3.09	3.11	3.13	3.15	3.17	3.19	3.21	3.23
31.	3.10	3.12	3.15	3.17	3.19	3.21	3.23	3.25	3.27
30.	3.14	3.16	3.18	3.20	3.22	3.24	3.26	3.28	3.31
29.	3.17	3.20	3.22	3.24	3.26	3.28	3.30	3.32	3.34
28.	3.21	3.23	3.25	3.27	3.29	3.31	3.33	3.36	3.38
27.	3.25	3.27	3.29	3.31	3.33	3.35	3.37	3.39	3.41
26.	3.28	3.30	3.32	3.34	3.36	3.39	3.41	3.43	3.45
25.	3.32	3.34	3.36	3.38	3.40	3.42	3.44	3.46	3.48
24.	3.35	3.37	3.39	3.42	3.44	3.46	3.48	3.50	3.52
23.	3.39	3.41	3.43	3.45	3.47	3.49	3.51	3.54	3.56
22.	3.42	3.45	3.47	3.49	3.51	3.53	3.55	3.57	3.59
21.	3.46	3.48	3.50	3.52	3.54	3.57	3.59	3.61	3.63
20.	3.50	3.52	3.54	3.56	3.58	3.60	3.62	3.64	3.67
19.	3.53	3.55	3.58	3.60	3.62	3.64	3.66	3.68	3.70
18.	3.57	3.59	3.61	3.63	3.65	3.68	3.70	3.72	3.74
17.	3.61	3.63	3.65	3.67	3.69	3.71	3.73	3.75	3.78
16.	3.64	3.66	3.69	3.71	3.73	3.75	3.77	3.79	3.81
15.	3.68	3.70	3.72	3.74	3.76	3.79	3.81	3.83	3.85
14.	3.72	3.74	3.76	3.78	3.80	3.82	3.84	3.87	3.89
13.	3.75	3.77	3.80	3.82	3.84	3.86	3.88	3.90	3.92
12.	3.79	3.81	3.83	3.85	3.88	3.90	3.92	3.94	3.96
11.	3.83	3.85	3.87	3.89	3.91	3.93	3.96	3.98	4.00
10.	3.87	3.89	3.91	3.93	3.95	3.97	3.99	4.01	4.04
9.	3.90	3.92	3.95	3.97	3.99	4.01	4.03	4.05	4.07
8.	3.94	3.96	3.98	4.00	4.03	4.05	4.07	4.09	4.11
7.	3.98	4.00	4.02	4.04	4.06	4.09	4.11	4.13	4.15
6.	4.02	4.04	4.06	4.08	4.10	4.12	4.14	4.17	4.19
5.	4.05	4.08	4.10	4.12	4.14	4.16	4.18	4.20	4.23
4.	4.09	4.11	4.13	4.16	4.18	4.20	4.22	4.24	4.26
3.	4.13	4.15	4.17	4.19	4.22	4.24	4.26	4.28	4.30
2.	4.17	4.19	4.21	4.23	4.25	4.28	4.30	4.32	4.34
1.	4.21	4.23	4.25	4.27	4.29	4.31	4.34	4.36	4.38
0.	4.24	4.27	4.29	4.31	4.33	4.35	4.37	4.40	4.42
-1.	4.28	4.31	4.33	4.35	4.37	4.39	4.41	4.44	4.46
-2.	4.32	4.34	4.37	4.39	4.41	4.43	4.45	4.47	4.50
-3.	4.36	4.38	4.40	4.43	4.45	4.47	4.49	4.51	4.54
-4.	4.40	4.42	4.44	4.47	4.49	4.51	4.53	4.55	4.57
-5.	4.44	4.46	4.48	4.50	4.53	4.55	4.57	4.59	4.61
-6.	4.48	4.50	4.52	4.54	4.57	4.59	4.61	4.63	4.65
-7.	4.52	4.54	4.56	4.58	4.61	4.63	4.65	4.67	4.69
-8.	4.56	4.58	4.60	4.62	4.64	4.67	4.69	4.71	4.73
-9.	4.60	4.62	4.64	4.66	4.68	4.71	4.73	4.75	4.77
-10.	4.64	4.66	4.68	4.70	4.72	4.75	4.77	4.79	4.81
-11.	4.68	4.70	4.72	4.74	4.76	4.79	4.81	4.83	4.85
-12.	4.72	4.74	4.76	4.78	4.80	4.83	4.85	4.87	4.89
-13.	4.76	4.78	4.80	4.82	4.84	4.87	4.89	4.91	4.93
-14.	4.80	4.82	4.84	4.86	4.89	4.91	4.93	4.95	4.97
-15.	4.84	4.86	4.88	4.90	4.93	4.95	4.97	4.99	
-16.	4.88	4.90	4.92	4.94	4.97				
-17.	4.92	4.94	4.96	4.98					
-18.	4.96	4.98							
-19.	5.00								
-20.									
	11.11	11.12	11.13	11.14	11.15	11.16	11.17	11.18	11.19
	Heater Resistance (Ohm) ----->								

GO TO NEXT PAGE

12.56. BLADE DE-ICE CONTROLLER ADJUSTMENT - continued

TABLE II. TAIL ROTOR BLADE ADJUSTMENT CHARTS (cont)

Blade Temp. (°C)	Tail Rotor Adjustment Resistance (Kiloohm)								
50.	2.64	2.66	2.68	2.70	2.72	2.74	2.76	2.78	2.80
49.	2.67	2.69	2.71	2.73	2.75	2.77	2.79	2.81	2.83
48.	2.70	2.72	2.74	2.76	2.78	2.80	2.82	2.85	2.87
47.	2.74	2.76	2.78	2.80	2.82	2.84	2.86	2.88	2.90
46.	2.77	2.79	2.81	2.83	2.85	2.87	2.89	2.91	2.93
45.	2.81	2.83	2.85	2.87	2.89	2.91	2.93	2.95	2.97
44.	2.84	2.86	2.88	2.90	2.92	2.94	2.96	2.98	3.00
43.	2.87	2.89	2.91	2.93	2.95	2.98	3.00	3.02	3.04
42.	2.91	2.93	2.95	2.97	2.99	3.01	3.03	3.05	3.07
41.	2.94	2.96	2.98	3.00	3.02	3.04	3.06	3.08	3.11
40.	2.98	3.00	3.02	3.04	3.06	3.08	3.10	3.12	3.14
39.	3.01	3.03	3.05	3.07	3.09	3.11	3.13	3.15	3.17
38.	3.05	3.07	3.09	3.11	3.13	3.15	3.17	3.19	3.21
37.	3.08	3.10	3.12	3.14	3.16	3.18	3.20	3.22	3.24
36.	3.11	3.14	3.16	3.18	3.20	3.22	3.24	3.26	3.28
35.	3.15	3.17	3.19	3.21	3.23	3.25	3.27	3.29	3.31
34.	3.18	3.21	3.23	3.25	3.27	3.29	3.31	3.33	3.35
33.	3.22	3.24	3.26	3.28	3.30	3.32	3.34	3.36	3.39
32.	3.26	3.28	3.30	3.32	3.34	3.36	3.38	3.40	3.42
31.	3.29	3.31	3.33	3.35	3.37	3.39	3.41	3.44	3.46
30.	3.33	3.35	3.37	3.39	3.41	3.43	3.45	3.47	3.49
29.	3.36	3.38	3.40	3.42	3.44	3.47	3.49	3.51	3.53
28.	3.40	3.42	3.44	3.46	3.48	3.50	3.52	3.54	3.56
27.	3.43	3.45	3.47	3.50	3.52	3.54	3.56	3.58	3.60
26.	3.47	3.49	3.51	3.53	3.55	3.57	3.59	3.61	3.64
25.	3.50	3.53	3.55	3.57	3.59	3.61	3.63	3.65	3.67
24.	3.54	3.56	3.58	3.60	3.62	3.65	3.67	3.69	3.71
23.	3.58	3.60	3.62	3.64	3.66	3.68	3.70	3.72	3.74
22.	3.61	3.63	3.66	3.68	3.70	3.72	3.74	3.76	3.78
21.	3.65	3.67	3.69	3.71	3.73	3.75	3.78	3.80	3.82
20.	3.69	3.71	3.73	3.75	3.77	3.79	3.81	3.83	3.85
19.	3.72	3.74	3.77	3.79	3.81	3.83	3.85	3.87	3.89
18.	3.76	3.78	3.80	3.82	3.84	3.87	3.89	3.91	3.93
17.	3.80	3.82	3.84	3.86	3.88	3.90	3.92	3.94	3.97
16.	3.83	3.85	3.88	3.90	3.92	3.94	3.96	3.98	4.00
15.	3.87	3.89	3.91	3.93	3.96	3.98	4.00	4.02	4.04
14.	3.91	3.93	3.95	3.97	3.99	4.01	4.04	4.06	4.08
13.	3.94	3.97	3.99	4.01	4.03	4.05	4.07	4.09	4.12
12.	3.98	4.00	4.02	4.05	4.07	4.09	4.11	4.13	4.15
11.	4.02	4.04	4.06	4.08	4.11	4.13	4.15	4.17	4.19
10.	4.06	4.08	4.10	4.12	4.14	4.16	4.19	4.21	4.23
9.	4.10	4.12	4.14	4.16	4.18	4.20	4.22	4.24	4.27
8.	4.13	4.15	4.18	4.20	4.22	4.24	4.26	4.28	4.30
7.	4.17	4.19	4.21	4.24	4.26	4.28	4.30	4.32	4.34
6.	4.21	4.23	4.25	4.27	4.30	4.32	4.34	4.36	4.38
5.	4.25	4.27	4.29	4.31	4.33	4.35	4.38	4.40	4.42
4.	4.29	4.31	4.33	4.35	4.37	4.39	4.41	4.44	4.46
3.	4.32	4.35	4.37	4.39	4.41	4.43	4.45	4.48	4.50
2.	4.36	4.38	4.41	4.43	4.45	4.47	4.49	4.51	4.54
1.	4.40	4.42	4.44	4.47	4.49	4.51	4.53	4.55	4.57
0.	4.44	4.46	4.48	4.51	4.53	4.55	4.57	4.59	4.61
-1.	4.48	4.50	4.52	4.54	4.57	4.59	4.61	4.63	4.65
-2.	4.52	4.54	4.56	4.58	4.61	4.63	4.65	4.67	4.69
-3.	4.56	4.58	4.60	4.62	4.64	4.67	4.69	4.71	4.73
-4.	4.60	4.62	4.64	4.66	4.68	4.71	4.73	4.75	4.77
-5.	4.64	4.66	4.68	4.70	4.72	4.75	4.77	4.79	4.81
-6.	4.68	4.70	4.72	4.74	4.76	4.78	4.81	4.83	4.85
-7.	4.71	4.74	4.76	4.78	4.80	4.82	4.85	4.87	4.89
-8.	4.75	4.78	4.80	4.82	4.84	4.86	4.89	4.91	4.93
-9.	4.79	4.82	4.84	4.86	4.88	4.90	4.93	4.95	4.97
-10.	4.83	4.86	4.88	4.90	4.92	4.94	4.97	4.99	
-11.	4.87	4.90	4.92	4.94	4.96				
-12.	4.92	4.94	4.96	4.98					
-13.	4.96	4.98	5.00						
-14.	5.00								
-15.									
-16.									
-17.									
-18.									
-19.									
-20.									
	11.20	11.21	11.22	11.23	11.24	11.25	11.26	11.27	11.28
	Heater Resistance (Ohm) ----->								

GO TO NEXT PAGE

12.56. BLADE DE-ICE CONTROLLER ADJUSTMENT - continued

TABLE II. TAIL ROTOR BLADE ADJUSTMENT CHARTS (cont)

Blade Temp. (°C)	Tail Rotor Adjustment Resistance (Kiloohm)								
	2.82	2.84	2.86	2.88	2.90	2.92	2.94	2.96	2.98
50.	2.82	2.84	2.86	2.88	2.90	2.92	2.94	2.96	2.98
49.	2.85	2.87	2.89	2.91	2.93	2.95	2.97	2.99	3.01
48.	2.89	2.91	2.93	2.95	2.97	2.99	3.01	3.03	3.05
47.	2.92	2.94	2.96	2.98	3.00	3.02	3.04	3.06	3.08
46.	2.95	2.97	2.99	3.01	3.03	3.05	3.08	3.10	3.12
45.	2.99	3.01	3.03	3.05	3.07	3.09	3.11	3.13	3.15
44.	3.02	3.04	3.06	3.08	3.10	3.12	3.14	3.16	3.18
43.	3.06	3.08	3.10	3.12	3.14	3.16	3.18	3.20	3.22
42.	3.09	3.11	3.13	3.15	3.17	3.19	3.21	3.23	3.25
41.	3.13	3.15	3.17	3.19	3.21	3.23	3.25	3.27	3.29
40.	3.16	3.18	3.20	3.22	3.24	3.26	3.28	3.30	3.32
39.	3.19	3.22	3.24	3.26	3.28	3.30	3.32	3.34	3.36
38.	3.23	3.25	3.27	3.29	3.31	3.33	3.35	3.37	3.39
37.	3.26	3.29	3.31	3.33	3.35	3.37	3.39	3.41	3.43
36.	3.30	3.32	3.34	3.36	3.38	3.40	3.42	3.44	3.46
35.	3.34	3.36	3.38	3.40	3.42	3.44	3.46	3.48	3.50
34.	3.37	3.39	3.41	3.43	3.45	3.47	3.49	3.51	3.54
33.	3.41	3.43	3.45	3.47	3.49	3.51	3.53	3.55	3.57
32.	3.44	3.46	3.48	3.50	3.52	3.54	3.57	3.59	3.61
31.	3.48	3.50	3.52	3.54	3.56	3.58	3.60	3.62	3.64
30.	3.51	3.53	3.55	3.57	3.60	3.62	3.64	3.66	3.68
29.	3.55	3.57	3.59	3.61	3.63	3.65	3.67	3.69	3.71
28.	3.58	3.61	3.63	3.65	3.67	3.69	3.71	3.73	3.75
27.	3.62	3.64	3.66	3.68	3.70	3.72	3.75	3.77	3.79
26.	3.66	3.68	3.70	3.72	3.74	3.76	3.78	3.80	3.82
25.	3.69	3.71	3.73	3.76	3.78	3.80	3.82	3.84	3.86
24.	3.73	3.75	3.77	3.79	3.81	3.83	3.85	3.88	3.90
23.	3.77	3.79	3.81	3.83	3.85	3.87	3.89	3.91	3.93
22.	3.80	3.82	3.84	3.87	3.89	3.91	3.93	3.95	3.97
21.	3.84	3.86	3.88	3.90	3.92	3.94	3.96	3.99	4.01
20.	3.88	3.90	3.92	3.94	3.96	3.98	4.00	4.02	4.04
19.	3.91	3.93	3.95	3.98	4.00	4.02	4.04	4.06	4.08
18.	3.95	3.97	3.99	4.01	4.03	4.06	4.08	4.10	4.12
17.	3.99	4.01	4.03	4.05	4.07	4.09	4.11	4.13	4.16
16.	4.02	4.05	4.07	4.09	4.11	4.13	4.15	4.17	4.19
15.	4.06	4.08	4.10	4.12	4.15	4.17	4.19	4.21	4.23
14.	4.10	4.12	4.14	4.16	4.18	4.20	4.23	4.25	4.27
13.	4.14	4.16	4.18	4.20	4.22	4.24	4.26	4.29	4.31
12.	4.17	4.20	4.22	4.24	4.26	4.28	4.30	4.32	4.34
11.	4.21	4.23	4.25	4.28	4.30	4.32	4.34	4.36	4.38
10.	4.25	4.27	4.29	4.31	4.34	4.36	4.38	4.40	4.42
9.	4.29	4.31	4.33	4.35	4.37	4.39	4.42	4.44	4.46
8.	4.33	4.35	4.37	4.39	4.41	4.43	4.45	4.48	4.50
7.	4.36	4.39	4.41	4.43	4.45	4.47	4.49	4.51	4.54
6.	4.40	4.42	4.45	4.47	4.49	4.51	4.53	4.55	4.57
5.	4.44	4.46	4.48	4.51	4.53	4.55	4.57	4.59	4.61
4.	4.48	4.50	4.52	4.54	4.57	4.59	4.61	4.63	4.65
3.	4.52	4.54	4.56	4.58	4.60	4.63	4.65	4.67	4.69
2.	4.56	4.58	4.60	4.62	4.64	4.67	4.69	4.71	4.73
1.	4.60	4.62	4.64	4.66	4.68	4.70	4.73	4.75	4.77
0.	4.64	4.66	4.68	4.70	4.72	4.74	4.77	4.79	4.81
-1.	4.67	4.70	4.72	4.74	4.76	4.78	4.80	4.83	4.85
-2.	4.71	4.74	4.76	4.78	4.80	4.82	4.84	4.87	4.89
-3.	4.75	4.78	4.80	4.82	4.84	4.86	4.88	4.91	4.93
-4.	4.79	4.81	4.84	4.86	4.88	4.90	4.92	4.95	4.97
-5.	4.83	4.85	4.88	4.90	4.92	4.94	4.96		
-6.	4.87	4.89	4.92	4.94	4.96				
-7.	4.91	4.93	4.96	4.98					
-8.	4.95	4.97	5.00						
-9.	4.99								
-10.									
-11.									
-12.									
-13.									
-14.									
-15.									
-16.									
-17.									
-18.									
-19.									
-20.									
	11.29	11.30	11.31	11.32	11.33	11.34	11.35	11.36	11.37
	Heater Resistance (Ohm) ----->								

GO TO NEXT PAGE

12.56. BLADE DE-ICE CONTROLLER ADJUSTMENT - continued

TABLE II. TAIL ROTOR BLADE ADJUSTMENT CHARTS (cont)

Blade Temp. (°C)	Tail Rotor Adjustment Resistance (Kiloohm)								
	3.00	3.02	3.04	3.06	3.08	3.10	3.12	3.14	3.16
50.	3.00	3.02	3.04	3.06	3.08	3.10	3.12	3.14	3.16
49.	3.03	3.05	3.07	3.09	3.11	3.13	3.15	3.17	3.19
48.	3.07	3.09	3.11	3.13	3.15	3.17	3.19	3.21	3.23
47.	3.10	3.12	3.14	3.16	3.18	3.20	3.22	3.24	3.26
46.	3.14	3.16	3.18	3.20	3.22	3.24	3.26	3.28	3.30
45.	3.17	3.19	3.21	3.23	3.25	3.27	3.29	3.31	3.33
44.	3.20	3.23	3.25	3.27	3.29	3.31	3.33	3.35	3.37
43.	3.24	3.26	3.28	3.30	3.32	3.34	3.36	3.38	3.40
42.	3.27	3.29	3.32	3.34	3.36	3.38	3.40	3.42	3.44
41.	3.31	3.33	3.35	3.37	3.39	3.41	3.43	3.45	3.47
40.	3.34	3.36	3.38	3.41	3.43	3.45	3.47	3.49	3.51
39.	3.38	3.40	3.42	3.44	3.46	3.48	3.50	3.52	3.54
38.	3.41	3.43	3.46	3.48	3.50	3.52	3.54	3.56	3.58
37.	3.45	3.47	3.49	3.51	3.53	3.55	3.57	3.59	3.61
36.	3.48	3.51	3.53	3.55	3.57	3.59	3.61	3.63	3.65
35.	3.52	3.54	3.56	3.58	3.60	3.62	3.64	3.66	3.69
34.	3.56	3.58	3.60	3.62	3.64	3.66	3.68	3.70	3.72
33.	3.59	3.61	3.63	3.65	3.67	3.69	3.72	3.74	3.76
32.	3.63	3.65	3.67	3.69	3.71	3.73	3.75	3.77	3.79
31.	3.66	3.68	3.70	3.73	3.75	3.77	3.79	3.81	3.83
30.	3.70	3.72	3.74	3.76	3.78	3.80	3.82	3.84	3.87
29.	3.74	3.76	3.78	3.80	3.82	3.84	3.86	3.88	3.90
28.	3.77	3.79	3.81	3.83	3.85	3.88	3.90	3.92	3.94
27.	3.81	3.83	3.85	3.87	3.89	3.91	3.93	3.95	3.97
26.	3.84	3.87	3.89	3.91	3.93	3.95	3.97	3.99	4.01
25.	3.88	3.90	3.92	3.94	3.96	3.99	4.01	4.03	4.05
24.	3.92	3.94	3.96	3.98	4.00	4.02	4.04	4.06	4.08
23.	3.95	3.98	4.00	4.02	4.04	4.06	4.08	4.10	4.12
22.	3.99	4.01	4.03	4.05	4.07	4.10	4.12	4.14	4.16
21.	4.03	4.05	4.07	4.09	4.11	4.13	4.15	4.18	4.20
20.	4.07	4.09	4.11	4.13	4.15	4.17	4.19	4.21	4.23
19.	4.10	4.12	4.14	4.17	4.19	4.21	4.23	4.25	4.27
18.	4.14	4.16	4.18	4.20	4.22	4.25	4.27	4.29	4.31
17.	4.18	4.20	4.22	4.24	4.26	4.28	4.30	4.32	4.35
16.	4.21	4.24	4.26	4.28	4.30	4.32	4.34	4.36	4.38
15.	4.25	4.27	4.29	4.32	4.34	4.36	4.38	4.40	4.42
14.	4.29	4.31	4.33	4.35	4.37	4.40	4.42	4.44	4.46
13.	4.33	4.35	4.37	4.39	4.41	4.43	4.46	4.48	4.50
12.	4.37	4.39	4.41	4.43	4.45	4.47	4.49	4.51	4.54
11.	4.40	4.43	4.45	4.47	4.49	4.51	4.53	4.55	4.57
10.	4.44	4.46	4.48	4.51	4.53	4.55	4.57	4.59	4.61
9.	4.48	4.50	4.52	4.54	4.57	4.59	4.61	4.63	4.65
8.	4.52	4.54	4.56	4.58	4.60	4.63	4.65	4.67	4.69
7.	4.56	4.58	4.60	4.62	4.64	4.66	4.69	4.71	4.73
6.	4.60	4.62	4.64	4.66	4.68	4.70	4.72	4.75	4.77
5.	4.63	4.66	4.68	4.70	4.72	4.74	4.76	4.79	4.81
4.	4.67	4.70	4.72	4.74	4.76	4.78	4.80	4.82	4.85
3.	4.71	4.73	4.76	4.78	4.80	4.82	4.84	4.86	4.89
2.	4.75	4.77	4.80	4.82	4.84	4.86	4.88	4.90	4.92
1.	4.79	4.81	4.83	4.86	4.88	4.90	4.92	4.94	4.96
0.	4.83	4.85	4.87	4.90	4.92	4.94	4.96	4.98	
-1.	4.87	4.89	4.91	4.94	4.96	4.98			
-2.	4.91	4.93	4.95	4.97	5.00				
-3.	4.95	4.97							
-4.	4.99								
-5.									
-6.									
-7.									
-8.									
-9.									
-10.									
-11.									
-12.									
-13.									
-14.									
-15.									
-16.									
-17.									
-18.									
-19.									
-20.									
	11.38	11.39	11.40	11.41	11.42	11.43	11.44	11.45	11.46
	Heater Resistance (Ohm) ----->								

GO TO NEXT PAGE

12.56. BLADE DE-ICE CONTROLLER ADJUSTMENT - continued

TABLE II. TAIL ROTOR BLADE ADJUSTMENT CHARTS (cont)

Blade Temp. (°C)	Tail Rotor Adjustment Resistance (Kiloohm)								
50.	3.18	3.20	3.22	3.24	3.26	3.28	3.30	3.32	3.34
49.	3.21	3.23	3.25	3.28	3.30	3.32	3.34	3.36	3.38
48.	3.25	3.27	3.29	3.31	3.33	3.35	3.37	3.39	3.41
47.	3.28	3.30	3.32	3.34	3.36	3.38	3.40	3.43	3.45
46.	3.32	3.34	3.36	3.38	3.40	3.42	3.44	3.46	3.48
45.	3.35	3.37	3.39	3.41	3.43	3.45	3.47	3.49	3.52
44.	3.39	3.41	3.43	3.45	3.47	3.49	3.51	3.53	3.55
43.	3.42	3.44	3.46	3.48	3.50	3.52	3.54	3.57	3.59
42.	3.46	3.48	3.50	3.52	3.54	3.56	3.58	3.60	3.62
41.	3.49	3.51	3.53	3.55	3.57	3.59	3.62	3.64	3.66
40.	3.53	3.55	3.57	3.59	3.61	3.63	3.65	3.67	3.69
39.	3.56	3.58	3.60	3.62	3.65	3.67	3.69	3.71	3.73
38.	3.60	3.62	3.64	3.66	3.68	3.70	3.72	3.74	3.76
37.	3.63	3.65	3.68	3.70	3.72	3.74	3.76	3.78	3.80
36.	3.67	3.69	3.71	3.73	3.75	3.77	3.79	3.81	3.83
35.	3.71	3.73	3.75	3.77	3.79	3.81	3.83	3.85	3.87
34.	3.74	3.76	3.78	3.80	3.82	3.84	3.87	3.89	3.91
33.	3.78	3.80	3.82	3.84	3.86	3.88	3.90	3.92	3.94
32.	3.81	3.83	3.85	3.88	3.90	3.92	3.94	3.96	3.98
31.	3.85	3.87	3.89	3.91	3.93	3.95	3.97	3.99	4.02
30.	3.89	3.91	3.93	3.95	3.97	3.99	4.01	4.03	4.05
29.	3.92	3.94	3.96	3.98	4.01	4.03	4.05	4.07	4.09
28.	3.96	3.98	4.00	4.02	4.04	4.06	4.08	4.10	4.13
27.	4.00	4.02	4.04	4.06	4.08	4.10	4.12	4.14	4.16
26.	4.03	4.05	4.07	4.09	4.12	4.14	4.16	4.18	4.20
25.	4.07	4.09	4.11	4.13	4.15	4.17	4.19	4.22	4.24
24.	4.11	4.13	4.15	4.17	4.19	4.21	4.23	4.25	4.27
23.	4.14	4.16	4.18	4.21	4.23	4.25	4.27	4.29	4.31
22.	4.18	4.20	4.22	4.24	4.26	4.28	4.31	4.33	4.35
21.	4.22	4.24	4.26	4.28	4.30	4.32	4.34	4.36	4.39
20.	4.25	4.28	4.30	4.32	4.34	4.36	4.38	4.40	4.42
19.	4.29	4.31	4.33	4.36	4.38	4.40	4.42	4.44	4.46
18.	4.33	4.35	4.37	4.39	4.41	4.44	4.46	4.48	4.50
17.	4.37	4.39	4.41	4.43	4.45	4.47	4.49	4.52	4.54
16.	4.41	4.43	4.45	4.47	4.49	4.51	4.53	4.55	4.57
15.	4.44	4.46	4.49	4.51	4.53	4.55	4.57	4.59	4.61
14.	4.48	4.50	4.52	4.54	4.57	4.59	4.61	4.63	4.65
13.	4.52	4.54	4.56	4.58	4.60	4.63	4.65	4.67	4.69
12.	4.56	4.58	4.60	4.62	4.64	4.66	4.69	4.71	4.73
11.	4.60	4.62	4.64	4.66	4.68	4.70	4.72	4.75	4.77
10.	4.63	4.66	4.68	4.70	4.72	4.74	4.76	4.78	4.81
9.	4.67	4.69	4.72	4.74	4.76	4.78	4.80	4.82	4.84
8.	4.71	4.73	4.75	4.78	4.80	4.82	4.84	4.86	4.88
7.	4.75	4.77	4.79	4.81	4.84	4.86	4.88	4.90	4.92
6.	4.79	4.81	4.83	4.85	4.88	4.90	4.92	4.94	4.96
5.	4.83	4.85	4.87	4.89	4.91	4.94	4.96	4.98	
4.	4.87	4.89	4.91	4.93	4.95	4.98	5.00		
3.	4.91	4.93	4.95	4.97	4.99				
2.	4.95	4.97	4.99						
1.	4.99								
0.									
-1.									
-2.									
-3.									
-4.									
-5.									
-6.									
-7.									
-8.									
-9.									
-10.									
-11.									
-12.									
-13.									
-14.									
-15.									
-16.									
-17.									
-18.									
-19.									
-20.									
	11.47	11.48	11.49	11.50	11.51	11.52	11.53	11.54	11.55

Heater Resistance (Ohm) ----->

GO TO NEXT PAGE



12.56. BLADE DE-ICE CONTROLLER ADJUSTMENT - continued

TABLE II. TAIL ROTOR BLADE ADJUSTMENT CHARTS (cont)

Blade Temp. (°C)	Tail Rotor Adjustment Resistance (Kiloohm)								
50.	3.36	3.38	3.40	3.42	3.44	3.46	3.48	3.50	3.52
49.	3.40	3.42	3.44	3.46	3.48	3.50	3.52	3.54	3.56
48.	3.43	3.45	3.47	3.49	3.51	3.53	3.55	3.57	3.59
47.	3.47	3.49	3.51	3.53	3.55	3.57	3.59	3.61	3.63
46.	3.50	3.52	3.54	3.56	3.58	3.60	3.62	3.64	3.66
45.	3.54	3.56	3.58	3.60	3.62	3.64	3.66	3.68	3.70
44.	3.57	3.59	3.61	3.63	3.65	3.67	3.69	3.71	3.73
43.	3.61	3.63	3.65	3.67	3.69	3.71	3.73	3.75	3.77
42.	3.64	3.66	3.68	3.70	3.72	3.74	3.76	3.78	3.80
41.	3.68	3.70	3.72	3.74	3.76	3.78	3.80	3.82	3.84
40.	3.71	3.73	3.75	3.77	3.79	3.81	3.83	3.85	3.88
39.	3.75	3.77	3.79	3.81	3.83	3.85	3.87	3.89	3.91
38.	3.78	3.80	3.82	3.84	3.87	3.89	3.91	3.93	3.95
37.	3.82	3.84	3.86	3.88	3.90	3.92	3.94	3.96	3.98
36.	3.85	3.88	3.90	3.92	3.94	3.96	3.98	4.00	4.02
35.	3.89	3.91	3.93	3.95	3.97	3.99	4.01	4.03	4.06
34.	3.93	3.95	3.97	3.99	4.01	4.03	4.05	4.07	4.09
33.	3.96	3.98	4.00	4.03	4.05	4.07	4.09	4.11	4.13
32.	4.00	4.02	4.04	4.06	4.08	4.10	4.12	4.14	4.16
31.	4.04	4.06	4.08	4.10	4.12	4.14	4.16	4.18	4.20
30.	4.07	4.09	4.11	4.13	4.16	4.18	4.20	4.22	4.24
29.	4.11	4.13	4.15	4.17	4.19	4.21	4.23	4.25	4.28
28.	4.15	4.17	4.19	4.21	4.23	4.25	4.27	4.29	4.31
27.	4.18	4.20	4.22	4.25	4.27	4.29	4.31	4.33	4.35
26.	4.22	4.24	4.26	4.28	4.30	4.32	4.34	4.37	4.39
25.	4.26	4.28	4.30	4.32	4.34	4.36	4.38	4.40	4.42
24.	4.29	4.31	4.34	4.36	4.38	4.40	4.42	4.44	4.46
23.	4.33	4.35	4.37	4.39	4.42	4.44	4.46	4.48	4.50
22.	4.37	4.39	4.41	4.43	4.45	4.47	4.49	4.52	4.54
21.	4.41	4.43	4.45	4.47	4.49	4.51	4.53	4.55	4.57
20.	4.44	4.46	4.49	4.51	4.53	4.55	4.57	4.59	4.61
19.	4.48	4.50	4.52	4.54	4.57	4.59	4.61	4.63	4.65
18.	4.52	4.54	4.56	4.58	4.60	4.63	4.65	4.67	4.69
17.	4.56	4.58	4.60	4.62	4.64	4.66	4.68	4.71	4.73
16.	4.60	4.62	4.64	4.66	4.68	4.70	4.72	4.74	4.76
15.	4.63	4.65	4.68	4.70	4.72	4.74	4.76	4.78	4.80
14.	4.67	4.69	4.71	4.74	4.76	4.78	4.80	4.82	4.84
13.	4.71	4.73	4.75	4.77	4.80	4.82	4.84	4.86	4.88
12.	4.75	4.77	4.79	4.81	4.83	4.86	4.88	4.90	4.92
11.	4.79	4.81	4.83	4.85	4.87	4.89	4.92	4.94	4.96
10.	4.83	4.85	4.87	4.89	4.91	4.93	4.95	4.98	5.00
9.	4.87	4.89	4.91	4.93	4.95	4.97	4.99		
8.	4.90	4.93	4.95	4.97					
7.	4.94	4.97	4.99						
6.	4.98								
5.									
4.									
3.									
2.									
1.									
0.									
-1.									
-2.									
-3.									
-4.									
-5.									
-6.									
-7.									
-8.									
-9.									
-10.									
-11.									
-12.									
-13.									
-14.									
-15.									
-16.									
-17.									
-18.									
-19.									
-20.									
	11.56	11.57	11.58	11.59	11.60	11.61	11.62	11.63	11.64
	Heater Resistance (Ohm) ----->								

GO TO NEXT PAGE

12.56. BLADE DE-ICE CONTROLLER ADJUSTMENT - continued

TABLE II. TAIL ROTOR BLADE ADJUSTMENT CHARTS (cont)

Blade Temp. (°C)	Tail Rotor Adjustment Resistance (Kiloohm)								
50.	3.54	3.56	3.58	3.60	3.62	3.64	3.66	3.68	3.70
49.	3.58	3.60	3.62	3.64	3.66	3.68	3.70	3.72	3.74
48.	3.61	3.63	3.65	3.67	3.69	3.71	3.73	3.75	3.77
47.	3.65	3.67	3.69	3.71	3.73	3.75	3.77	3.79	3.81
46.	3.68	3.70	3.72	3.74	3.76	3.78	3.80	3.82	3.84
45.	3.72	3.74	3.76	3.78	3.80	3.82	3.84	3.86	3.88
44.	3.75	3.77	3.79	3.81	3.83	3.85	3.88	3.90	3.92
43.	3.79	3.81	3.83	3.85	3.87	3.89	3.91	3.93	3.95
42.	3.82	3.84	3.87	3.89	3.91	3.93	3.95	3.97	3.99
41.	3.86	3.88	3.90	3.92	3.94	3.96	3.98	4.00	4.02
40.	3.90	3.92	3.94	3.96	3.98	4.00	4.02	4.04	4.06
39.	3.93	3.95	3.97	3.99	4.01	4.03	4.05	4.07	4.10
38.	3.97	3.99	4.01	4.03	4.05	4.07	4.09	4.11	4.13
37.	4.00	4.02	4.04	4.07	4.09	4.11	4.13	4.15	4.17
36.	4.04	4.06	4.08	4.10	4.12	4.14	4.16	4.18	4.20
35.	4.08	4.10	4.12	4.14	4.16	4.18	4.20	4.22	4.24
34.	4.11	4.13	4.15	4.17	4.19	4.22	4.24	4.26	4.28
33.	4.15	4.17	4.19	4.21	4.23	4.25	4.27	4.29	4.31
32.	4.19	4.21	4.23	4.25	4.27	4.29	4.31	4.33	4.35
31.	4.22	4.24	4.26	4.28	4.31	4.33	4.35	4.37	4.39
30.	4.26	4.28	4.30	4.32	4.34	4.36	4.38	4.40	4.43
29.	4.30	4.32	4.34	4.36	4.38	4.40	4.42	4.44	4.46
28.	4.33	4.35	4.37	4.40	4.42	4.44	4.46	4.48	4.50
27.	4.37	4.39	4.41	4.43	4.45	4.47	4.50	4.52	4.54
26.	4.41	4.43	4.45	4.47	4.49	4.51	4.53	4.55	4.57
25.	4.44	4.47	4.49	4.51	4.53	4.55	4.57	4.59	4.61
24.	4.48	4.50	4.52	4.55	4.57	4.59	4.61	4.63	4.65
23.	4.52	4.54	4.56	4.58	4.60	4.62	4.65	4.67	4.69
22.	4.56	4.58	4.60	4.62	4.64	4.66	4.68	4.70	4.73
21.	4.60	4.62	4.64	4.66	4.68	4.70	4.72	4.74	4.76
20.	4.63	4.65	4.68	4.70	4.72	4.74	4.76	4.78	4.80
19.	4.67	4.69	4.71	4.73	4.76	4.78	4.80	4.82	4.84
18.	4.71	4.73	4.75	4.77	4.79	4.82	4.84	4.86	4.88
17.	4.75	4.77	4.79	4.81	4.83	4.85	4.87	4.90	4.92
16.	4.79	4.81	4.83	4.85	4.87	4.89	4.91	4.93	4.96
15.	4.82	4.85	4.87	4.89	4.91	4.93	4.95	4.97	4.99
14.	4.86	4.88	4.91	4.93	4.95	4.97	4.99		
13.	4.90	4.92	4.94	4.97	4.99				
12.	4.94	4.96	4.98						
11.	4.98								
10.									
9.									
8.									
7.									
6.									
5.									
4.									
3.									
2.									
1.									
0.									
-1.									
-2.									
-3.									
-4.									
-5.									
-6.									
-7.									
-8.									
-9.									
-10.									
-11.									
-12.									
-13.									
-14.									
-15.									
-16.									
-17.									
-18.									
-19.									
-20.									
	11.65	11.66	11.67	11.68	11.69	11.70	11.71	11.72	11.73
	Heater Resistance (Ohm) ----->								

GO TO NEXT PAGE

12.56. BLADE DE-ICE CONTROLLER ADJUSTMENT - continued

TABLE II. TAIL ROTOR BLADE ADJUSTMENT CHARTS (cont)

Blade Temp. (°C)	Tail Rotor Adjustment Resistance (Kiloohm)								
50.	3.72	3.74	3.76	3.78	3.80	3.82	3.84	3.87	3.89
49.	3.76	3.78	3.80	3.82	3.84	3.86	3.88	3.90	3.92
48.	3.79	3.81	3.83	3.86	3.88	3.90	3.92	3.94	3.96
47.	3.83	3.85	3.87	3.89	3.91	3.93	3.95	3.97	3.99
46.	3.87	3.89	3.91	3.93	3.95	3.97	3.99	4.01	4.03
45.	3.90	3.92	3.94	3.96	3.98	4.00	4.02	4.04	4.06
44.	3.94	3.96	3.98	4.00	4.02	4.04	4.06	4.08	4.10
43.	3.97	3.99	4.01	4.03	4.05	4.07	4.09	4.11	4.13
42.	4.01	4.03	4.05	4.07	4.09	4.11	4.13	4.15	4.17
41.	4.04	4.06	4.08	4.10	4.13	4.15	4.17	4.19	4.21
40.	4.08	4.10	4.12	4.14	4.16	4.18	4.20	4.22	4.24
39.	4.12	4.14	4.16	4.18	4.20	4.22	4.24	4.26	4.28
38.	4.15	4.17	4.19	4.21	4.23	4.25	4.28	4.30	4.32
37.	4.19	4.21	4.23	4.25	4.27	4.29	4.31	4.33	4.35
36.	4.22	4.25	4.27	4.29	4.31	4.33	4.35	4.37	4.39
35.	4.26	4.28	4.30	4.32	4.34	4.36	4.38	4.41	4.43
34.	4.30	4.32	4.34	4.36	4.38	4.40	4.42	4.44	4.46
33.	4.33	4.36	4.38	4.40	4.42	4.44	4.46	4.48	4.50
32.	4.37	4.39	4.41	4.43	4.45	4.48	4.50	4.52	4.54
31.	4.41	4.43	4.45	4.47	4.49	4.51	4.53	4.55	4.57
30.	4.45	4.47	4.49	4.51	4.53	4.55	4.57	4.59	4.61
29.	4.48	4.50	4.52	4.55	4.57	4.59	4.61	4.63	4.65
28.	4.52	4.54	4.56	4.58	4.60	4.62	4.65	4.67	4.69
27.	4.56	4.58	4.60	4.62	4.64	4.66	4.68	4.70	4.72
26.	4.60	4.62	4.64	4.66	4.68	4.70	4.72	4.74	4.76
25.	4.63	4.65	4.67	4.70	4.72	4.74	4.76	4.78	4.80
24.	4.67	4.69	4.71	4.73	4.75	4.78	4.80	4.82	4.84
23.	4.71	4.73	4.75	4.77	4.79	4.81	4.83	4.86	4.88
22.	4.75	4.77	4.79	4.81	4.83	4.85	4.87	4.89	4.91
21.	4.78	4.81	4.83	4.85	4.87	4.89	4.91	4.93	4.95
20.	4.82	4.84	4.86	4.89	4.91	4.93	4.95	4.97	4.99
19.	4.86	4.88	4.90	4.92	4.95	4.97			
18.	4.90	4.92	4.94	4.96	4.98				
17.	4.94	4.96	4.98						
16.	4.98	5.00							
15.									
14.									
13.									
12.									
11.									
10.									
9.									
8.									
7.									
6.									
5.									
4.									
3.									
2.									
1.									
0.									
-1.									
-2.									
-3.									
-4.									
-5.									
-6.									
-7.									
-8.									
-9.									
-10.									
-11.									
-12.									
-13.									
-14.									
-15.									
-16.									
-17.									
-18.									
-19.									
-20.									
	11.74	11.75	11.76	11.77	11.78	11.79	11.80	11.81	11.82
	Heater Resistance (Ohm) ----->								

GO TO NEXT PAGE

12.56. BLADE DE-ICE CONTROLLER ADJUSTMENT - continued

TABLE II. TAIL ROTOR BLADE ADJUSTMENT CHARTS (cont)

Blade Temp. (°C)	Tail Rotor Adjustment Resistance (Kiloohm)									
	3.91	3.93	3.95	3.97	3.99	4.01	4.03	4.05	4.07	
50.	3.91	3.93	3.95	3.97	3.99	4.01	4.03	4.05	4.07	
49.	3.94	3.96	3.98	4.00	4.02	4.04	4.06	4.08	4.10	
48.	3.98	4.00	4.02	4.04	4.06	4.08	4.10	4.12	4.14	
47.	4.01	4.03	4.05	4.07	4.09	4.11	4.13	4.15	4.17	
46.	4.05	4.07	4.09	4.11	4.13	4.15	4.17	4.19	4.21	
45.	4.08	4.10	4.12	4.14	4.16	4.18	4.20	4.23	4.25	
44.	4.12	4.14	4.16	4.18	4.20	4.22	4.24	4.26	4.28	
43.	4.16	4.18	4.20	4.22	4.24	4.26	4.28	4.30	4.32	
42.	4.19	4.21	4.23	4.25	4.27	4.29	4.31	4.33	4.35	
41.	4.23	4.25	4.27	4.29	4.31	4.33	4.35	4.37	4.39	
40.	4.26	4.28	4.30	4.32	4.35	4.37	4.39	4.41	4.43	
39.	4.30	4.32	4.34	4.36	4.38	4.40	4.42	4.44	4.46	
38.	4.34	4.36	4.38	4.40	4.42	4.44	4.46	4.48	4.50	
37.	4.37	4.39	4.41	4.43	4.46	4.48	4.50	4.52	4.54	
36.	4.41	4.43	4.45	4.47	4.49	4.51	4.53	4.55	4.57	
35.	4.45	4.47	4.49	4.51	4.53	4.55	4.57	4.59	4.61	
34.	4.48	4.50	4.52	4.55	4.57	4.59	4.61	4.63	4.65	
33.	4.52	4.54	4.56	4.58	4.60	4.62	4.64	4.67	4.69	
32.	4.56	4.58	4.60	4.62	4.64	4.66	4.68	4.70	4.72	
31.	4.59	4.62	4.64	4.66	4.68	4.70	4.72	4.74	4.76	
30.	4.63	4.65	4.67	4.69	4.72	4.74	4.76	4.78	4.80	
29.	4.67	4.69	4.71	4.73	4.75	4.77	4.79	4.82	4.84	
28.	4.71	4.73	4.75	4.77	4.79	4.81	4.83	4.85	4.87	
27.	4.75	4.77	4.79	4.81	4.83	4.85	4.87	4.89	4.91	
26.	4.78	4.80	4.82	4.85	4.87	4.89	4.91	4.93	4.95	
25.	4.82	4.84	4.86	4.89	4.90	4.93	4.95	4.97	4.99	
24.	4.86	4.88	4.90	4.92	4.94	4.96	4.98			
23.	4.90	4.92	4.94	4.96	4.98					
22.	4.94	4.96	4.98	5.00						
21.	4.97	4.99								
20.										
19.										
18.										
17.										
16.										
15.										
14.										
13.										
12.										
11.										
10.										
9.										
8.										
7.										
6.										
5.										
4.										
3.										
2.										
1.										
0.										
-1.										
-2.										
-3.										
-4.										
-5.										
-6.										
-7.										
-8.										
-9.										
-10.										
-11.										
-12.										
-13.										
-14.										
-15.										
-16.										
-17.										
-18.										
-19.										
-20.										
	11.83	11.84	11.85	11.86	11.87	11.88	11.89	11.90	11.91	
	Heater Resistance (Ohm) ----->									

GO TO NEXT PAGE

12.56. BLADE DE-ICE CONTROLLER ADJUSTMENT - continued

TABLE II. TAIL ROTOR BLADE ADJUSTMENT CHARTS (cont)

Blade Temp. (°C)	Tail Rotor Adjustment Resistance (Kiloohm)								
50.	4.09	4.11	4.13	4.15	4.17	4.19	4.21	4.23	4.25
49.	4.12	4.14	4.16	4.18	4.20	4.22	4.24	4.26	4.28
48.	4.16	4.18	4.20	4.22	4.24	4.26	4.28	4.30	4.32
47.	4.19	4.21	4.23	4.25	4.27	4.30	4.32	4.34	4.36
46.	4.23	4.25	4.27	4.29	4.31	4.33	4.35	4.37	4.39
45.	4.27	4.29	4.31	4.33	4.35	4.37	4.39	4.41	4.43
44.	4.30	4.32	4.34	4.36	4.38	4.40	4.42	4.44	4.46
43.	4.34	4.36	4.38	4.40	4.42	4.44	4.46	4.48	4.50
42.	4.37	4.39	4.42	4.44	4.46	4.48	4.50	4.52	4.54
41.	4.41	4.43	4.45	4.47	4.49	4.51	4.53	4.55	4.57
40.	4.45	4.47	4.49	4.51	4.53	4.55	4.57	4.59	4.61
39.	4.48	4.50	4.53	4.55	4.57	4.59	4.61	4.63	4.65
38.	4.52	4.54	4.56	4.58	4.60	4.62	4.64	4.66	4.68
37.	4.56	4.58	4.60	4.62	4.64	4.66	4.68	4.70	4.72
36.	4.59	4.62	4.64	4.66	4.68	4.70	4.72	4.74	4.76
35.	4.63	4.65	4.67	4.69	4.71	4.73	4.76	4.78	4.80
34.	4.67	4.69	4.71	4.73	4.75	4.77	4.79	4.81	4.83
33.	4.71	4.73	4.75	4.77	4.79	4.81	4.83	4.85	4.87
32.	4.74	4.76	4.79	4.81	4.83	4.85	4.87	4.89	4.91
31.	4.78	4.80	4.82	4.84	4.86	4.88	4.91	4.93	4.95
30.	4.82	4.84	4.86	4.88	4.90	4.92	4.94	4.96	4.98
29.	4.86	4.88	4.90	4.92	4.94	4.96	4.98		
28.	4.89	4.92	4.94	4.96	4.98	5.00			
27.	4.93	4.95	4.97	5.00					
26.	4.97	4.99							
25.									
24.									
23.									
22.									
21.									
20.									
19.									
18.									
17.									
16.									
15.									
14.									
13.									
12.									
11.									
10.									
9.									
8.									
7.									
6.									
5.									
4.									
3.									
2.									
1.									
0.									
-1.									
-2.									
-3.									
-4.									
-5.									
-6.									
-7.									
-8.									
-9.									
-10.									
-11.									
-12.									
-13.									
-14.									
-15.									
-16.									
-17.									
-18.									
-19.									
-20.									
	11.92	11.93	11.94	11.95	11.96	11.97	11.98	11.99	12.00
	Heater Resistance (Ohm) ----->								

GO TO NEXT PAGE

12.56. BLADE DE-ICE CONTROLLER ADJUSTMENT - continued

TABLE II. TAIL ROTOR BLADE ADJUSTMENT CHARTS (cont)

Blade Temp. (°C)	Tail Rotor Adjustment Resistance (Kiloohm)								
	12.01	12.02	12.03	12.04	12.05	12.06	12.07	12.08	12.09
50.	4.27	4.29	4.31	4.33	4.35	4.37	4.39	4.41	4.43
49.	4.30	4.32	4.34	4.36	4.38	4.40	4.42	4.45	4.47
48.	4.34	4.36	4.38	4.40	4.42	4.44	4.46	4.48	4.50
47.	4.38	4.40	4.42	4.44	4.46	4.48	4.50	4.52	4.54
46.	4.41	4.43	4.45	4.47	4.49	4.51	4.53	4.55	4.57
45.	4.45	4.47	4.49	4.51	4.53	4.55	4.57	4.59	4.61
44.	4.48	4.51	4.53	4.55	4.57	4.59	4.61	4.63	4.65
43.	4.52	4.54	4.56	4.58	4.60	4.62	4.64	4.66	4.68
42.	4.56	4.58	4.60	4.62	4.64	4.66	4.68	4.70	4.72
41.	4.59	4.62	4.64	4.66	4.68	4.70	4.72	4.74	4.76
40.	4.63	4.65	4.67	4.69	4.71	4.73	4.75	4.77	4.79
39.	4.67	4.69	4.71	4.73	4.75	4.77	4.79	4.81	4.83
38.	4.71	4.73	4.75	4.77	4.79	4.81	5.83	4.85	4.87
37.	4.74	4.76	4.78	4.80	4.82	4.85	4.87	4.89	4.91
36.	4.78	4.80	4.82	4.84	4.86	4.88	4.90	4.92	4.94
35.	4.82	4.84	4.86	4.88	4.90	4.92	4.94	4.96	4.98
34.	4.85	4.88	4.90	4.92	4.94	4.96	4.98	5.00	
33.	4.89	4.91	4.93	4.95	4.97	5.00			
32.	4.93	4.95	4.97						
31.	4.97	4.99							
30.									
29.									
28.									
27.									
26.									
25.									
24.									
23.									
22.									
21.									
20.									
19.									
18.									
17.									
16.									
15.									
14.									
13.									
12.									
11.									
10.									
9.									
8.									
7.									
6.									
5.									
4.									
3.									
2.									
1.									
0.									
-1.									
-2.									
-3.									
-4.									
-5.									
-6.									
-7.									
-8.									
-9.									
-10.									
-11.									
-12.									
-13.									
-14.									
-15.									
-16.									
-17.									
-18.									
-19.									
-20.									

12.01 12.02 12.03 12.04 12.05 12.06 12.07 12.08 12.09  
 Heater Resistance (Ohm) ----->

GO TO NEXT PAGE

12.56. BLADE DE-ICE CONTROLLER ADJUSTMENT - continued

TABLE II. TAIL ROTOR BLADE ADJUSTMENT CHARTS (cont)

Blade Temp. (°C)	Tail Rotor Adjustment Resistance (Kiloohm)								
	12.10	12.11	12.12	12.13	12.14	12.15	12.16	12.17	12.18
50.	4.45	4.47	4.49	4.51	4.53	4.55	4.57	4.59	4.61
49.	4.49	4.51	4.53	4.55	4.57	4.59	4.61	4.63	4.65
48.	4.52	4.54	4.56	4.58	4.60	4.62	4.64	4.66	4.68
47.	4.56	4.58	4.60	4.62	4.64	4.66	4.68	4.70	4.72
46.	4.59	4.61	4.63	4.66	4.68	4.70	4.72	4.74	4.76
45.	4.63	4.65	4.67	4.69	4.71	4.73	4.75	4.77	4.79
44.	4.67	4.69	4.71	4.73	4.75	4.77	4.79	4.81	4.83
43.	4.70	4.72	4.75	4.77	4.79	4.81	4.83	4.85	4.87
42.	4.74	4.76	4.78	4.80	4.82	4.84	4.86	4.88	4.90
41.	4.78	4.80	4.82	4.84	4.86	4.88	4.90	4.92	4.94
40.	4.82	4.84	4.86	4.88	4.90	4.92	4.94	4.96	4.98
39.	4.85	4.87	4.89	4.91	4.93	4.95	4.98	5.00	
38.	4.89	4.91	4.93	4.95	4.97	4.99			
37.	4.93	4.95	4.97	4.99					
36.	4.96	4.99							
35.									
34.									
33.									
32.									
31.									
30.									
29.									
28.									
27.									
26.									
25.									
24.									
23.									
22.									
21.									
20.									
19.									
18.									
17.									
16.									
15.									
14.									
13.									
12.									
11.									
10.									
9.									
8.									
7.									
6.									
5.									
4.									
3.									
2.									
1.									
0.									
-1.									
-2.									
-3.									
-4.									
-5.									
-6.									
-7.									
-8.									
-9.									
-10.									
-11.									
-12.									
-13.									
-14.									
-15.									
-16.									
-17.									
-18.									
-19.									
-20.									

GO TO NEXT PAGE

12.56. BLADE DE-ICE CONTROLLER ADJUSTMENT - continued

TABLE II. TAIL ROTOR BLADE ADJUSTMENT CHARTS (cont)

Blade Temp. (°C)	Tail Rotor Adjustment Resistance (Kiloohm)									
	12.19	12.20	12.21	12.22	12.23	12.24	12.25	12.26	12.27	
50.	4.63	4.65	4.67	4.69	4.71	4.73	4.75	4.77	4.79	4.79
49.	4.67	4.69	4.71	4.73	4.75	4.77	4.79	4.81	4.83	
48.	4.70	4.72	4.74	4.76	4.78	4.80	4.82	4.84	4.87	
47.	4.74	4.76	4.78	4.80	4.82	4.84	4.86	4.88	4.90	
46.	4.78	4.80	4.82	4.84	4.86	4.88	4.90	4.92	4.94	
45.	4.81	4.83	4.85	4.87	4.89	4.92	4.94	4.96	4.98	
44.	4.85	4.87	4.89	4.91	4.93	4.95	4.97	4.99		
43.	4.89	4.91	4.93	4.95	4.97					
42.	4.92	4.95	4.97	4.99						
41.	4.96	4.98								
40.	5.00									
39.										
38.										
37.										
36.										
35.										
34.										
33.										
32.										
31.										
30.										
29.										
28.										
27.										
26.										
25.										
24.										
23.										
22.										
21.										
20.										
19.										
18.										
17.										
16.										
15.										
14.										
13.										
12.										
11.										
10.										
9.										
8.										
7.										
6.										
5.										
4.										
3.										
2.										
1.										
0.										
-1.										
-2.										
-3.										
-4.										
-5.										
-6.										
-7.										
-8.										
-9.										
-10.										
-11.										
-12.										
-13.										
-14.										
-15.										
-16.										
-17.										
-18.										
-19.										
-20.										

GO TO NEXT PAGE



12.56. BLADE DE-ICE CONTROLLER ADJUSTMENT - continued

TABLE II. TAIL ROTOR BLADE ADJUSTMENT CHARTS (cont)

Blade Temp. (°C)	Tail Rotor Adjustment Resistance (Kiloohm)								
	4.81	4.83	4.85	4.87	4.89	4.91	4.93	4.95	4.97
50.	4.81	4.83	4.85	4.87	4.89	4.91	4.93	4.95	4.97
49.	4.85	4.87	4.89	4.91	4.93	4.95	4.97	4.99	
48.	4.89	4.91	4.93	4.95	4.97	4.99			
47.	4.92	4.94	4.96	4.98					
46.	4.96	4.98	5.00						
45.	5.00								
44.									
43.									
42.									
41.									
40.									
39.									
38.									
37.									
36.									
35.									
34.									
33.									
32.									
31.									
30.									
29.									
28.									
27.									
26.									
25.									
24.									
23.									
22.									
21.									
20.									
19.									
18.									
17.									
16.									
15.									
14.									
13.									
12.									
11.									
10.									
9.									
8.									
7.									
6.									
5.									
4.									
3.									
2.									
1.									
0.									
-1.									
-2.									
-3.									
-4.									
-5.									
-6.									
-7.									
-8.									
-9.									
-10.									
-11.									
-12.									
-13.									
-14.									
-15.									
-16.									
-17.									
-18.									
-19.									
-20.									
	12.28	12.29	12.30	12.31	12.32	12.33	12.34	12.35	12.36
	Heater Resistance (Ohm) ----->								

END OF TASK

**12.57. ENGINE ANTI-ICE RELAY BOX REMOVAL/INSTALLATION**

12.57.1. Description

This task covers: Removal. Cleaning. Inspection. Installation.

12.57.2. Initial Setup

**Tools:**

- Electrical tool kit (item 378, App H)
- Light duty laboratory apron (item 27, App H)
- Chemical protective gloves (item 154, App H)
- Adjustable air filtering respirator (item 262, App H)

**References:**

TM 1-1520-238-T

**Materials/Parts:**

- Brush (item 34, App F)
- Sealing compound (item 175, App F)

**Equipment Conditions:**

**Personnel Required:**

- 68X Armament/Electrical System Repairer
- 68X3F Armament/Electrical System Repairer/  
Technical Inspector

<u>Ref</u>	<u>Condition</u>
1.57	Helicopter safed
2.2	Access doors T250L, T250R, T290L, T290R, and L325 opened

12.57.3. Removal

a. **Remove engine anti-ice relay box (1) from supports (2).**

- (1) Detach connector P1087 (3) from receptacle (A337)J1 (4).
- (2) Remove sealing compound from edges of box (1) mating surfaces and bolts.
- (3) Remove four bolts (5) and washers (6).
- (4) Remove box (1).

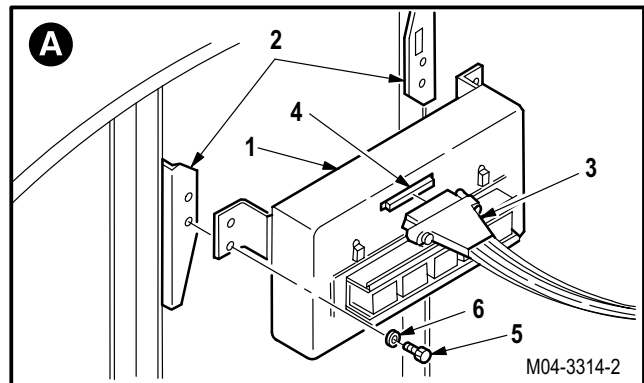
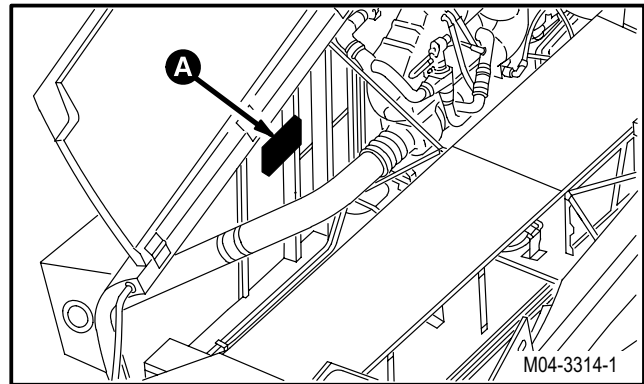

GO TO NEXT PAGE

---

**12.57. ENGINE ANTI-ICE RELAY BOX REMOVAL/INSTALLATION - continued**

---

12.57.4. Cleaning

- a. **Clean relay box mounting lugs and supports** (para 1.47).

12.57.5. Inspection

- a. **Check relay box supports and mounting lugs for cracks or deformation** (para 12.46).
- b. **Check removed and attaching parts for corrosion** (para 1.49).

12.57.6. Installation

- a. **Install box (1) on supports (2).**

- (1) Position box (1) on supports (2) with connector (A337)J1 (4) up and inboard.
- (2) Install four bolts (5) and washers (6).
- (3) Attach connector P1087 (3) to receptacle (A337)J1 (4).



- b. **Apply sealing compound to edges of relay box mating surfaces and bolts.** Use sealing compound (item 175, App F) and brush (item 34, App F).
- c. **Inspect (QA).**
- d. **Perform engine anti-ice maintenance operational check** (TM 1-1520-238-T).
- e. **Secure access doors T250L, T250R, T290L, T290R, and L325** (para 2.2).

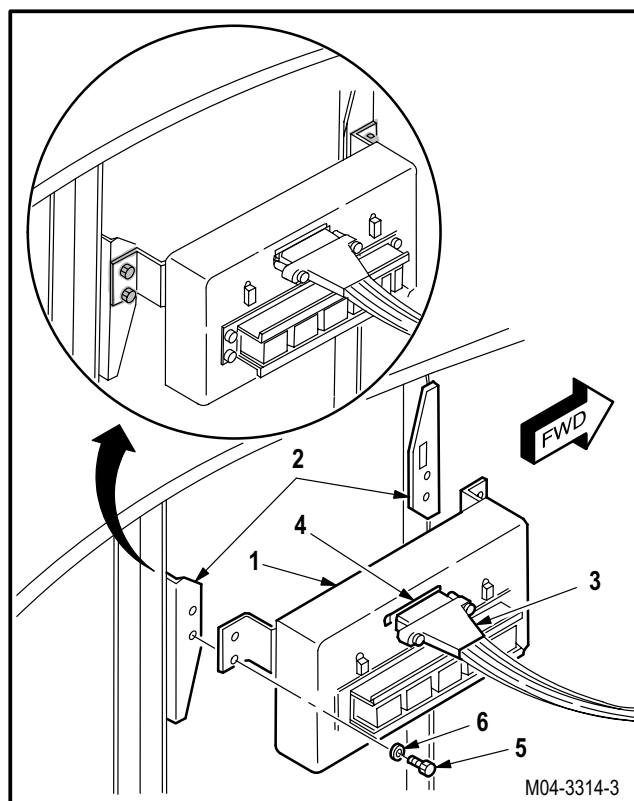

END OF TASK

**12.58. ENGINE ANTI-ICE RELAY BOX DISASSEMBLY/ASSEMBLY**

12.58.1. Description

This task covers: Disassembly. Cleaning. Inspection. Repair. Assembly.

12.58.2. Initial Setup

**Tools:**

Electrical tool kit (item 378, App H)  
 Captive installing tool (item 181, App H)

**References:**

TM 1-1500-204-23  
 TM 55-1500-323-24

**Personnel Required:**

68X Armament/Electrical System Repairer  
 68X3F Armament/Electrical System Repairer/  
 Technical Inspector

**Equipment Conditions:**

<u>Ref</u>	<u>Condition</u>
12.57	Engine anti-ice relay box removed

12.58.3. Disassembly

a. **Remove cover (1) from housing (2).**

- (1) Loosen four captive screws (3).
- (2) Remove cover (1).

b. **Remove lead (4) and chassis ground (5) from housing (2) and cover (1).**

- (1) Hold two screws (6).
- (2) Remove two nuts (7) from screws (6).
- (3) Remove screw (6), washer (8), and lead (4) from housing (2).
- (4) Remove screw (6), washer (8), lead (4), and chassis ground (5) from cover (1).

c. **Remove relays K1-1 (9), K1-2 (10), and K1-5/6 (11) from track (12) (para 9.139).**

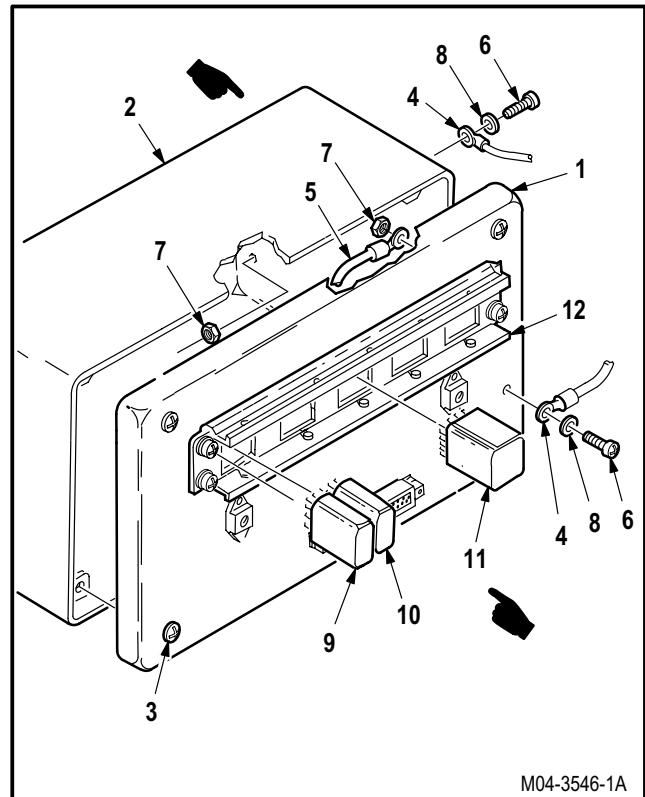

GO TO NEXT PAGE

■ 12.58. ENGINE ANTI-ICE RELAY BOX DISASSEMBLY/ASSEMBLY - continued

d. Remove TB1-3 terminal (13) from track (14).

- (1) Identify and depin wires (15) from terminal TB1-3 (13) (TM 55-1500-323-24).
- (2) Remove terminal TB1-3 (13) from track (14) (para 9.139).

e. Remove track (14) from cover (1).

- (1) Remove two screws (16) and washers (17).
- (2) Remove track (14).

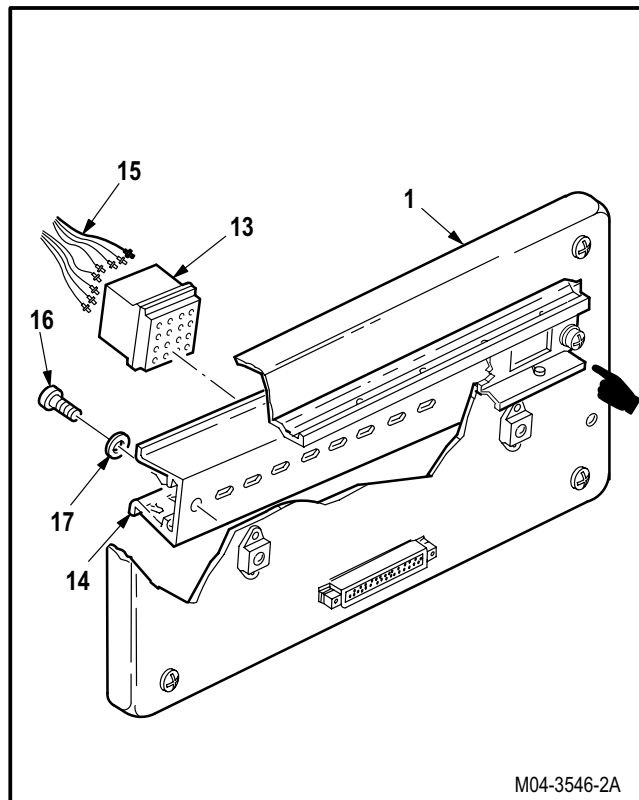

f. Remove XK1-1 and XK1-2 sockets (18) from track (12).

- (1) Identify and depin wires (19) from sockets (18) (TM 55-1500-323-24).
- (2) Remove sockets (18) from track (12) (para 9.139).

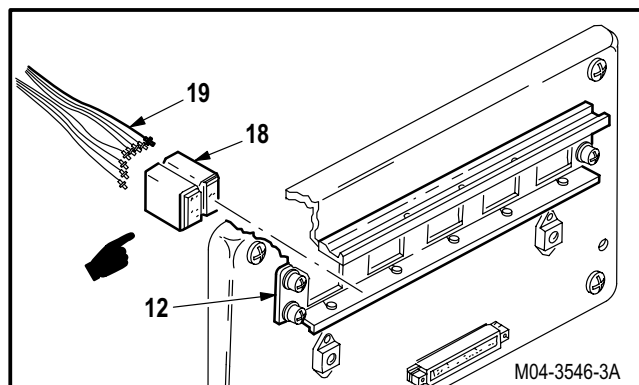

g. Remove XK1-5/6 socket (20) from track (12).

- (1) Identify and depin wires (21) from socket (20) (TM 55-1500-323-24).
- (2) Remove socket (20) from track (12) (para 9.139).

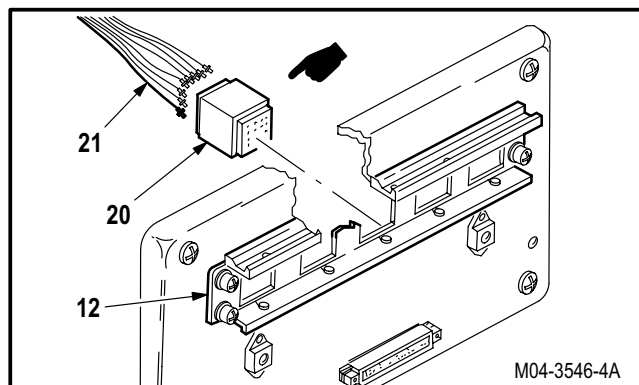

GO TO NEXT PAGE

■ 12.58. ENGINE ANTI-ICE RELAY BOX DISASSEMBLY/ASSEMBLY - continued

h. Remove track (12) from cover (1).

- (1) Hold four screws (22). Remove nuts (23).
- (2) Remove four screws (22), washers (24), and track (12) from cover (1).

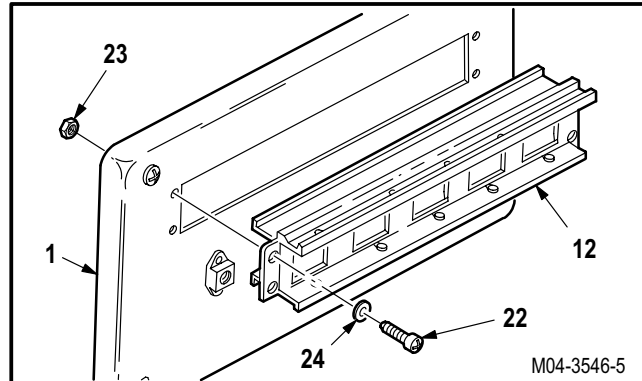

i. Detach connector (A337)J1 (25) from cover (1).

- (1) Hold adapter nut (26). Remove adapter screw (27).
- (2) Remove adapter nut (26), four panel washers (28), and connector (25) from cover (1).

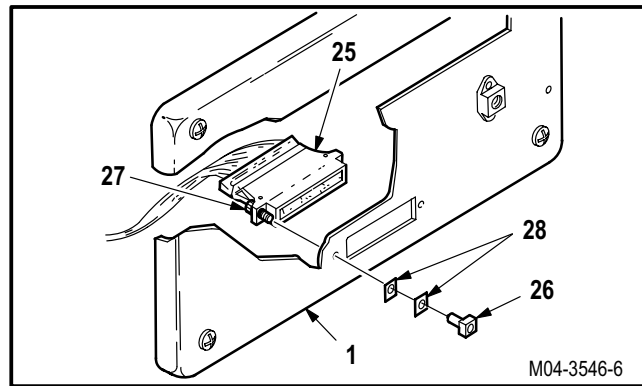

12.58.4. Cleaning

- a. **Wipe removed and attaching parts with a clean rag.**

12.58.5. Inspection

- a. **Check wires for cuts, nicks, fraying, or chafing** (para 12.46).
- b. **Check housing and cover for cracks** (para 12.46).
- c. **Check nutplates for stripped or damaged threads** (para 12.46).
- d. **Check removed and attaching parts for corrosion** (para 1.49).

GO TO NEXT PAGE

12.58. ENGINE ANTI-ICE RELAY BOX DISASSEMBLY/ASSEMBLY - continued

12.58.6. Repair

- a. Repair cover (1) by replacing nutplate (29) (TM 1-1500-204-23).

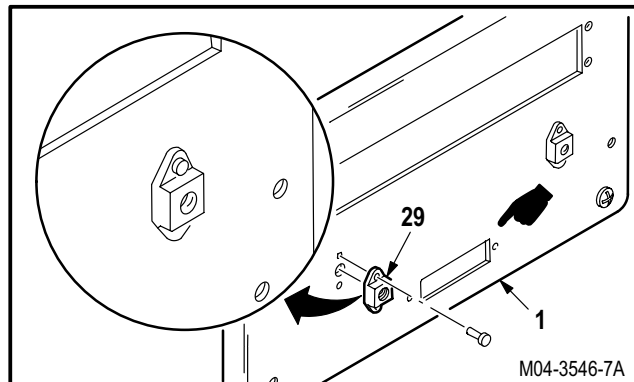

- b. Repair cover (1) by replacing captive screw (3).

- (1) Install removal nose (30) on captive installing tool (31). Use captive installing tool.
- (2) Place handle (32) of captive installing tool (31) in open position.
- (3) Position head of screw (3) in slot of removal nose (30).
- (4) Squeeze handle (32) of captive installing tool (31).
- (5) Remove and discard sleeve (33) and screw (3) from cover (1).
- (6) Remove removal nose (30) from captive installing tool (31).
- (7) Install new sleeve (33) and screw (3) through hole on cover (1).

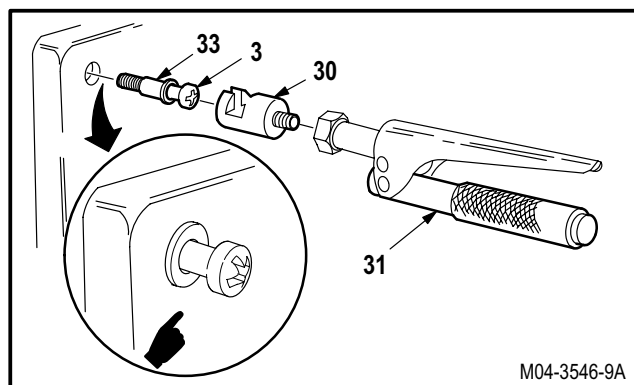
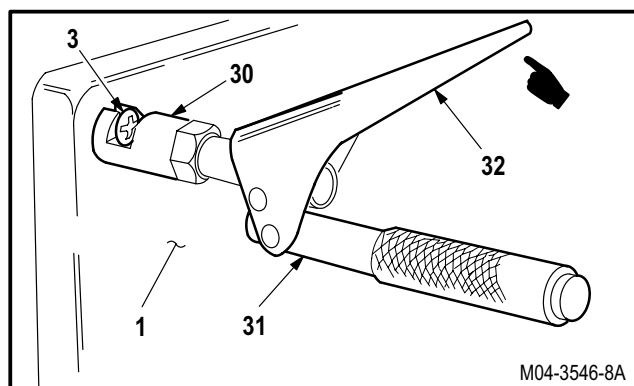

GO TO NEXT PAGE

12.58. ENGINE ANTI-ICE RELAY BOX DISASSEMBLY/ASSEMBLY - continued

(8) Turn screw (3) into captive installing tool (31) orifice.

(9) Place handle (32) of captive installing tool (31) in open position.

(10) Squeeze handle (32) of captive installing tool (31).

(11) Remove captive installing tool (31) from screw (3).

(a) Check sleeve (33) for radial or axial play. None allowed.

(b) Check sleeve (33) for smooth and even flare. No cracks allowed.

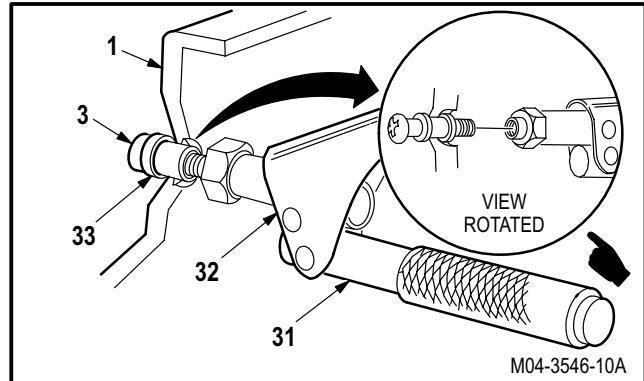

c. Repair housing (2) by replacing anchor nut (34) (TM 1-1500-204-23).

d. Repair housing (2) by replacing bracket mount (35) (TM 1-1500-204-23).

e. Repair damaged connector (A337)J1 (25) (para 9.138).

f. Repair damaged wire harness by replacing wire (TM 55-1500-323-24).

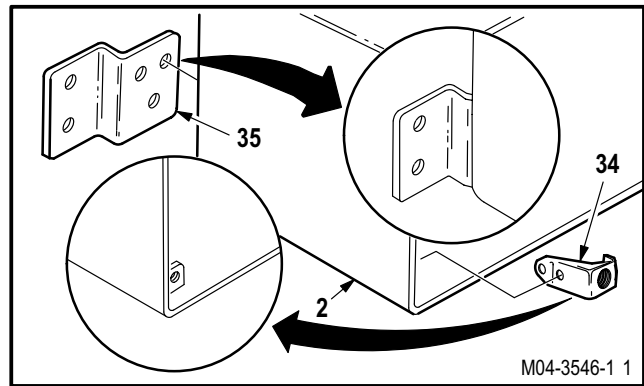

12.58.7. Assembly

a. Install connector (A337)J1 (25) on cover (1).

(1) Position connector (25) on backside of cover (1).

(2) Install four panel washers (28) and two adapter nuts (26) on two adapter screws (27).

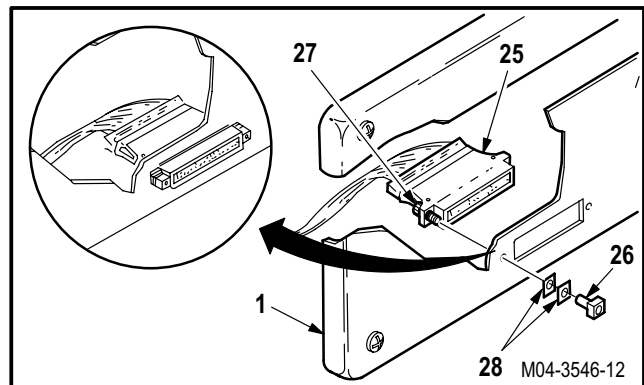

GO TO NEXT PAGE



■ **12.58. ENGINE ANTI-ICE RELAY BOX DISASSEMBLY/ASSEMBLY - continued**

**b. Install track (12) on cover (1).**

- (1) Install track (12) through front of cover (1).
- (2) Install four screws (22) through washers (24), track (12), and cover (1).
- (3) Install four nuts (23) on screws (22).

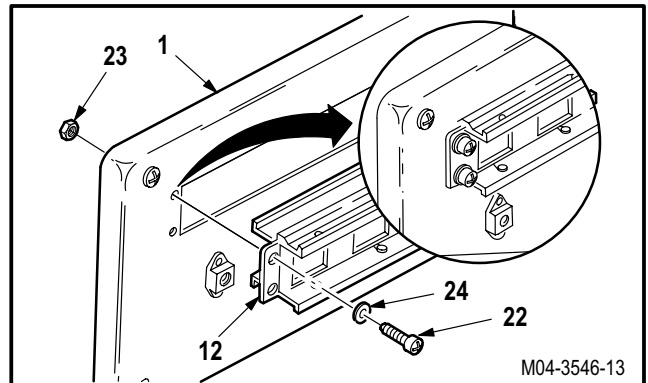

**c. Install XK1-5/6 socket (20) on track (12).**

- (1) Install socket XK1-5/6 (20) on track (12) (para 9.139).
- (2) Pin identified wires (21) in socket (20) (TM 55-1500-323-24).

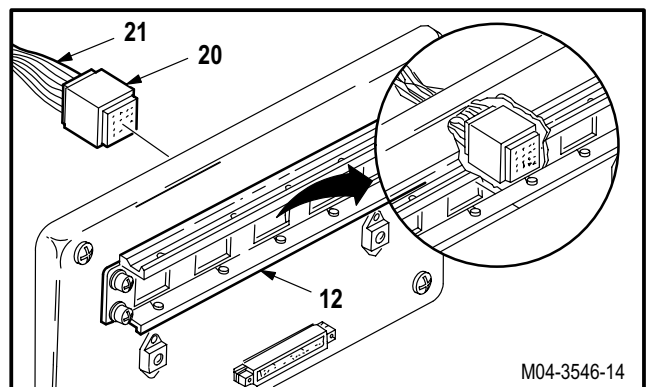

**d. Install XK1-1 and XK1-2 sockets (18) on track (12).**

- (1) Install sockets (18) on track (12) (para 9.139).
- (2) Pin identified wires (19) in sockets (18) (TM 55-1500-323-24).

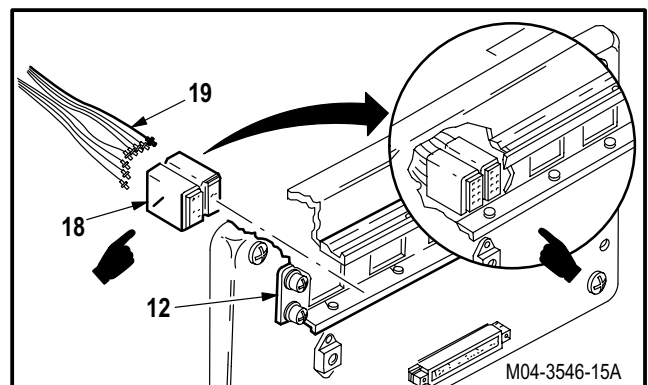

GO TO NEXT PAGE

■ 12.58. ENGINE ANTI-ICE RELAY BOX DISASSEMBLY/ASSEMBLY - continued

e. Install track (14) on cover (1).

- (1) Position track (14) on cover (1).
- (2) Install two screws (16) and washers (17).

f. Install TB1-3 terminal (13) on track (14).

- (1) Install terminal (13) on track (14) (para 9.139).
- (2) Pin identified wires (15) in terminal (13) (TM 55-1500-323-24).

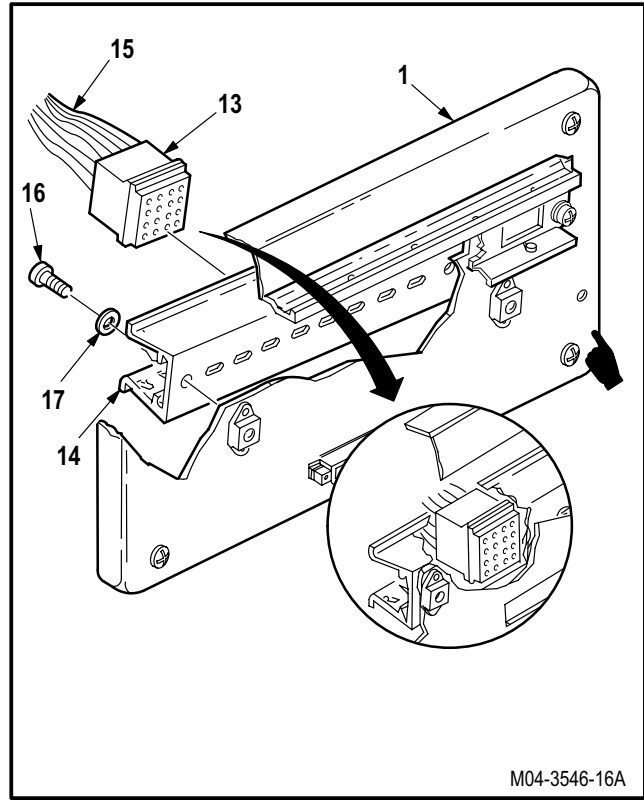

M04-3546-16A

g. Install lead (4) and chassis ground (5) on housing (2) and cover (1).

- (1) Install screw (6) through washer (8), lead (4), cover (1), and chassis ground (5).
- (2) Install screw (6) through washer (8), lead (4), and housing (2).
- (3) Hold two screws (6). Install two nuts (7).

h. Install relays K1-1 (9), K1-2 (10), K1-5/6 (11) in track (12) (para 9.139).

i. Install cover (1) on housing (2).

- (1) Position cover (1) on housing (2).
- (2) Tighten four captive screws (3).

j. Inspect (QA).

■ e. Install engine anti-ice relay box (para 12.57).

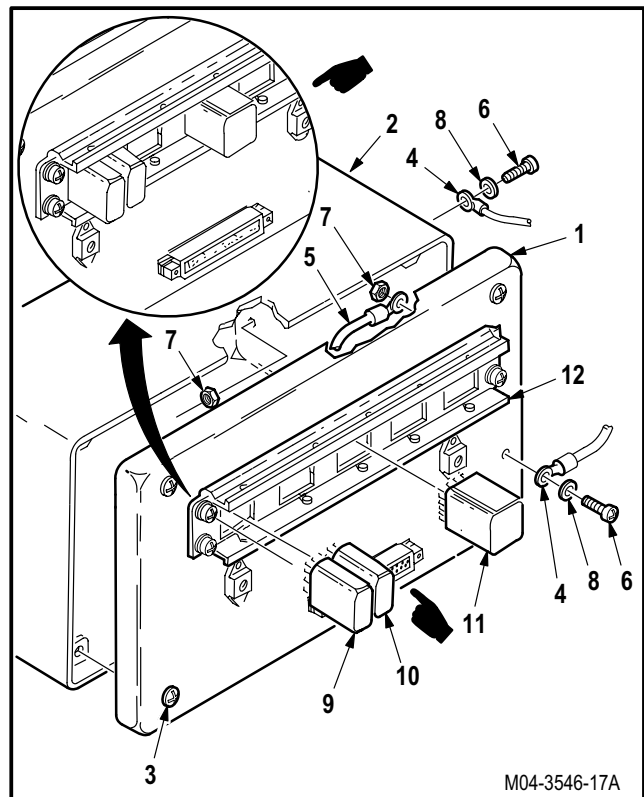

M04-3546-17A

END OF TASK

**12.59. ICE DETECTOR SIGNAL PROCESSOR REMOVAL/INSTALLATION**

12.59.1. Description

This task covers: Removal. Cleaning. Inspection. Installation.

12.59.2. Initial Setup

**Tools:**

Aircraft mechanic's tool kit (item 376, App H)

**References:**

TM 1-1520-238-T

**Equipment Conditions:**

<u>Ref</u>	<u>Condition</u>
1.57	Helicopter safed
2.2	Access doors T250L, T250R, T290L, T290R, and L325 opened

**Personnel Required:**

67R	Attack Helicopter Repairer
67R3F	Attack Helicopter Repairer/Technical Inspector

12.59.3. Removal

a. **Remove ice detector signal processor (1) from brackets (2).**

- (1) Detach connector P261 (3) from receptacle (A32)J1 (4).
- (2) Detach connector P262 (5) from receptacle (A32)J2 (6).
- (3) Remove four screws (7) and washers (8) from processor (1).
- (4) Remove processor (1).

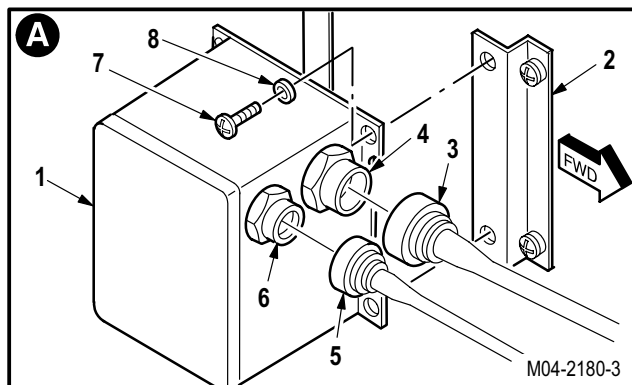
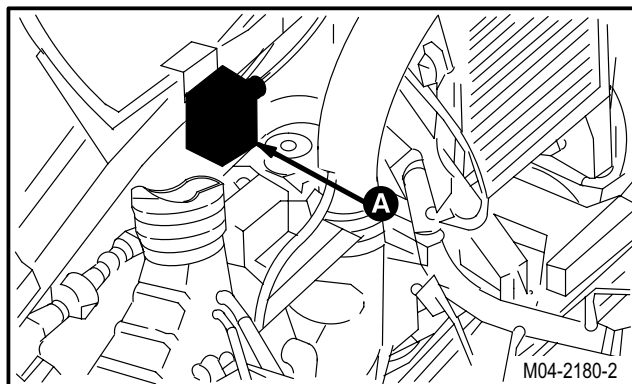

GO TO NEXT PAGE

---

**12.59. ICE DETECTOR SIGNAL PROCESSOR REMOVAL/INSTALLATION - continued**

---

12.59.4. Cleaning

- a. **Wipe removed and attaching parts with a clean rag.**

12.59.5. Inspection

- a. **Check processor for nicks, dents, or cracks** (para 12.46).
- b. **Check connectors for broken pins and stripped or damaged threads** (para 12.46).
- c. **Check removed and attaching parts for corrosion** (para 1.49).

12.59.6. Installation

- a. **Install processor (1) on brackets (2).**

- (1) Position processor (1) on brackets (2).
- (2) Install four screws (7) and washers (8) on processor (1).
- (3) Attach connector P261 (3) to receptacle (A32)J1 (4).
- (4) Attach connector P262 (5) to receptacle (A32)J2 (6).

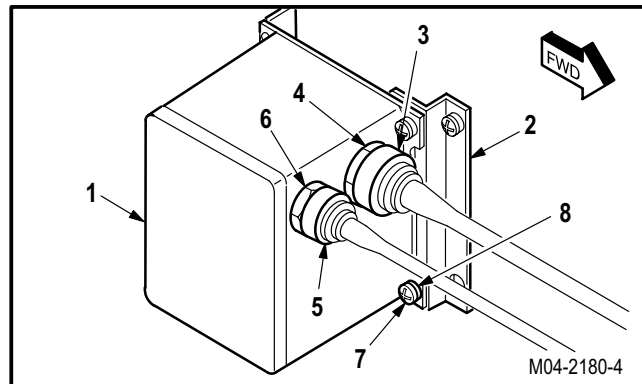

- b. **Inspect (QA).**
- c. **Secure access doors T250L, T250R, T290L, T290R, and L325** (para 2.2).
- d. **Perform rotor blades de-ice maintenance operational check** (TM 1-1520-238-T).

END OF TASK

**12.60. ICE DETECTOR SIGNAL PROCESSOR CIRCUIT CARD ASSEMBLY (CCA) STACK  
REMOVAL/INSTALLATION (AVIM)**

12.60.1. Description

This task covers: Removal. Cleaning. Inspection. Installation.

12.60.2. Initial Setup

**Tools:**

Electrical tool kit (item 378, App H)

**References:**

TM 11-6625-3085-30

**Personnel Required:**

68X Armament/Electrical System Repairer  
68X3F Armament/Electrical System Repairer/  
Technical Inspector

**NOTE**

- The EMI filters, connectors, and CCAs must be removed as a unit to prevent unnecessary disassembly and damage to unit.
- The purpose of this task is to facilitate other maintenance on the CCA stack.

12.60.3. Removal

a. **Remove cover (1) from processor housing (2).**

- (1) Remove four screws (3) and washers (4).
- (2) Remove cover (1).

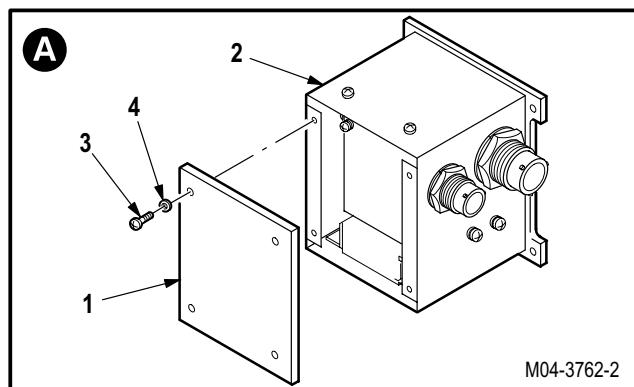
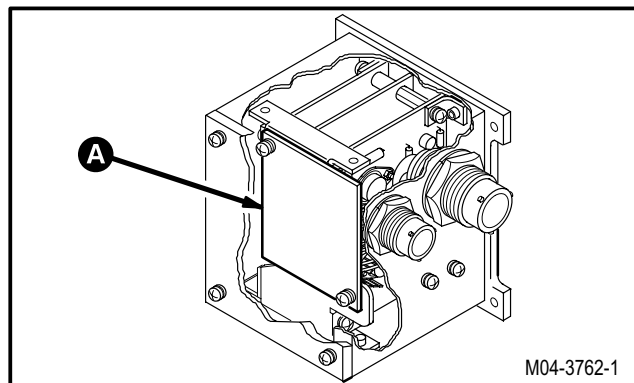

GO TO NEXT PAGE

**12.60. ICE DETECTOR SIGNAL PROCESSOR CIRCUIT CARD ASSEMBLY (CCA) STACK  
REMOVAL/INSTALLATION (AVIM) - continued**

**b. Remove circuit card assembly (CCA) stack (5) from housing (2).**

- (1) Remove nut (6) and retaining ring (7) from connector (A311)J1 (8).
- (2) Remove nut (9) and retaining ring (10) from connector (A311)J2 (11).
- (3) Remove two screws (12) and washers (13) from housing (2) and EMI filter bracket (14).
- (4) Remove four screws (15) from bottom of housing (2).
- (5) Remove four screws (16) and washers (17) from right and left side of housing (2).
- (6) Carefully remove CCA stack (5) from housing (2).
- (7) Remove and retain packings (18) and (19) from connectors (8) and (11).

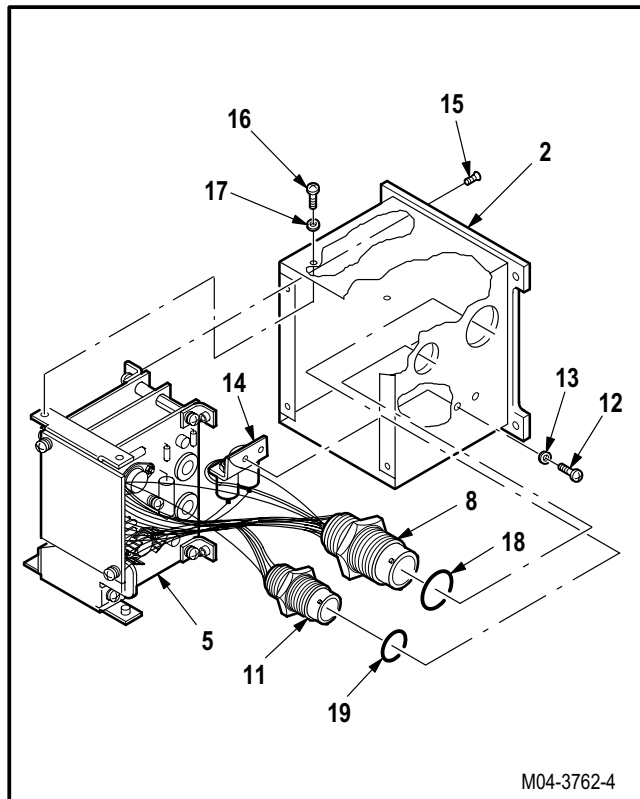
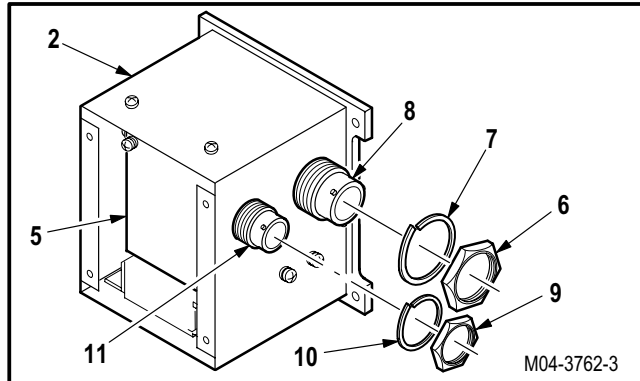

12.60.4. Cleaning

- a. **Clean removed and attaching parts** (para 1.47).

12.60.5. Inspection

- a. **Check housing for deformation or cracks** (para 12.46).
- b. **Check CCA stack components for damage** (para 12.46).
- c. **Check removed and attaching parts for corrosion** (para 1.49).

12.60.6. Installation

- a. **Install CCA stack (5) in housing (2).**

- (1) Install packings (18) and (19) on connectors (8) and (11).

GO TO NEXT PAGE

**12.60. ICE DETECTOR SIGNAL PROCESSOR CIRCUIT CARD ASSEMBLY (CCA) STACK  
REMOVAL/INSTALLATION (AVIM) - continued**

- (2) Carefully insert CCA stack (5) in housing (2).
- (3) Position EMI filter bracket (14) in housing (2).
- (4) Install two screws (12) and washers (13).
- (5) Position connectors (A311)J1 (8) and (A311)J2 (11) on housing (2).
- (6) Install retaining ring (7) and nut (6) on connector (A311)J1 (8).

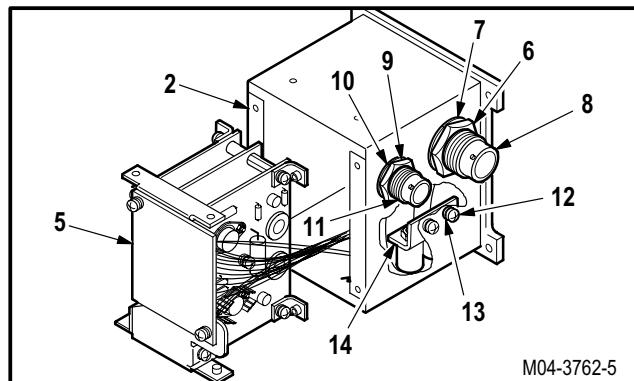

- (7) Install retaining ring (10) and nut (9) on connector (A311)J2 (11).
- (8) Position CCA stack (5) in housing (2).
- (9) Install four screws (15) on bottom of housing (2).
- (10) Install four screws (16) and washers (17) on right and left sides of housing (2).

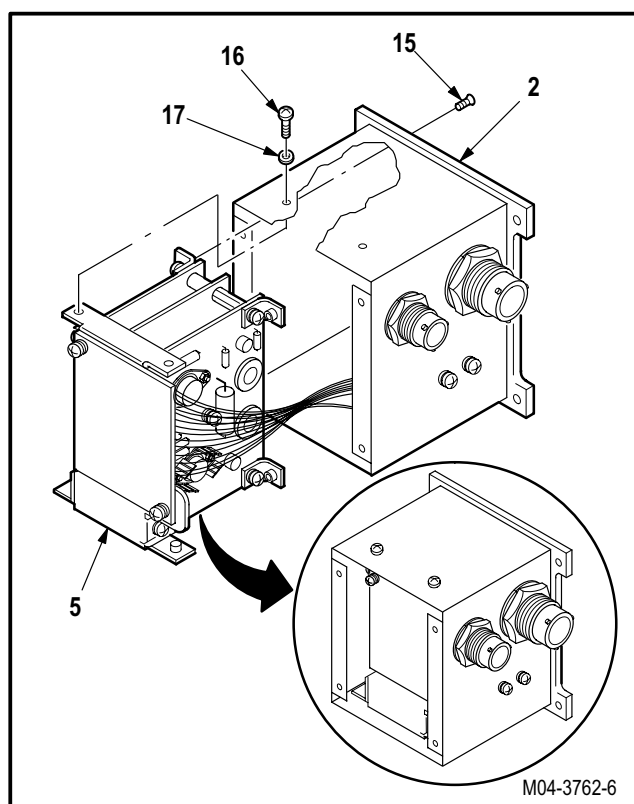

b. **Inspect (QA).**

c. **Install cover (1) on housing (2).**

- (1) Position cover (1) on housing (2).
- (2) Install four screws (3) and washers (4).

d. **Perform appropriate test.** Use Electronic Equipment Test Facility (EETF) (TM 11-6625-3085-30).

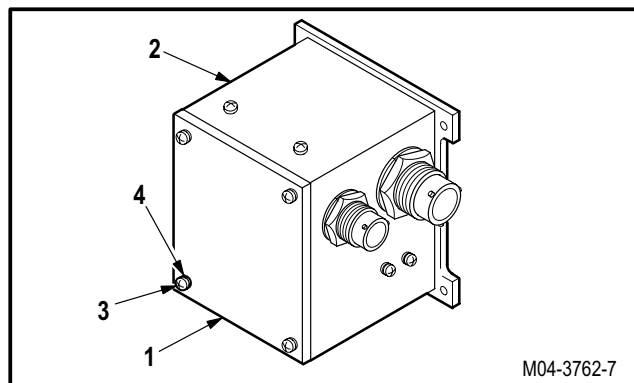

END OF TASK

---

**12.61. ICE DETECTOR SIGNAL PROCESSOR INTERCONNECTION CCA REPLACEMENT  
(AVIM)**

---

12.61.1. Description

This task covers: Removal. Cleaning. Inspection. Installation.

---

12.61.2. Initial Setup

**Tools:**

Electrical tool kit (item 378, App H)

**Personnel Required:**

68X Armament/Electrical System Repairer  
68X3F Armament/Electrical System Repairer/  
Technical Inspector

**Equipment Conditions:**

<u>Ref</u>	<u>Condition</u>
12.60	Ice detector signal processor CCA stack re- moved

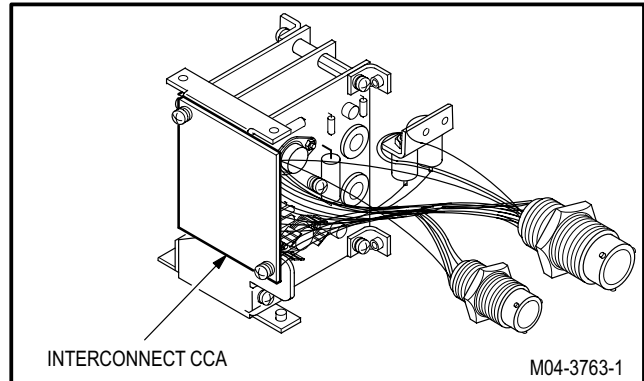

GO TO NEXT PAGE



## 12.61. ICE DETECTOR SIGNAL PROCESSOR INTERCONNECTION CCA REPLACEMENT (AVIM) - continued

### 12.61.3. Removal

#### a. Remove interconnection CCA (1) from CCA stack (2).

- (1) Remove two screws (3), washers (4), and nylon washers (5) from interconnection CCA (1).
- (2) Remove screw (8), lockwasher (9), and ground lead (6) from mounting bracket (7).
- (3) Carefully remove interconnection CCA (1) from CCA stack (2). Discard interconnection CCA (1).

### 12.61.4. Cleaning

#### a. Clean removed and attaching parts (para 1.47).

### 12.61.5. Inspection

#### a. Check CCA stack components for damage (para 12.46).

### 12.61.6. Installation

#### a. Install interconnection CCA (1) on CCA stack (2).

- (1) Carefully install interconnection CCA (1) with CCA stack (2).
- (2) Install screw (8) through lockwasher (9) and ground lead (6) on mounting bracket (7).
- (3) Install two screws (3) through washers (4), interconnection CCA (1), and nylon washers (5).

#### b. Inspect (QA).

#### c. Install ice detector signal processor CCA stack (para 12.60).

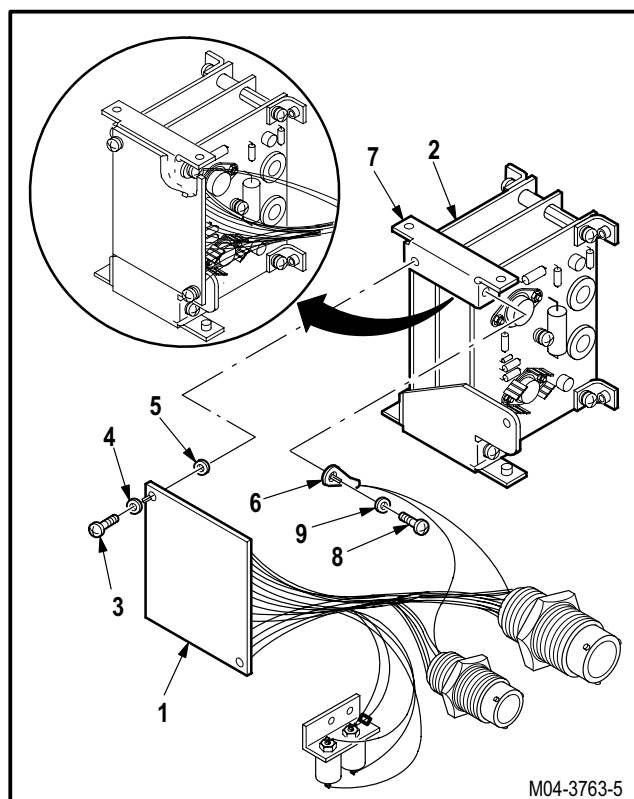
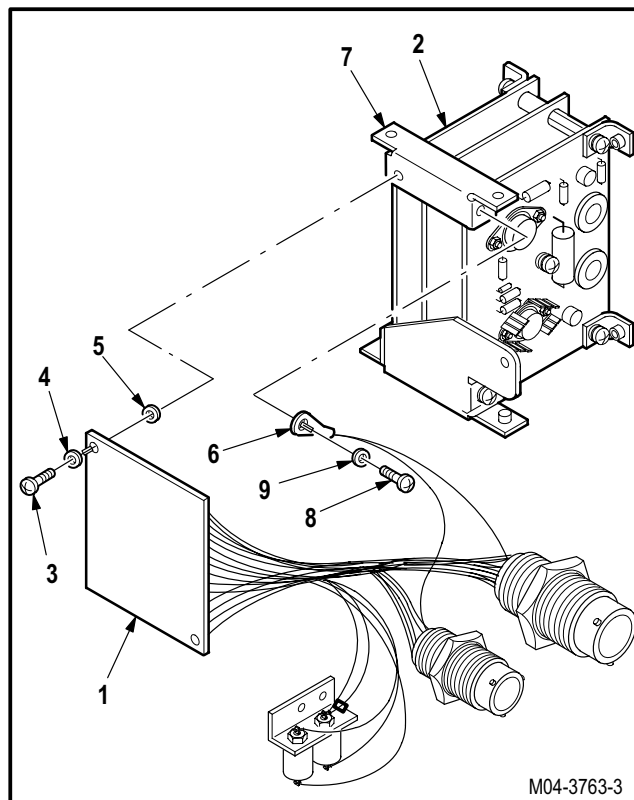

END OF TASK

---

**12.62. ICE DETECTOR SIGNAL PROCESSOR PROBE OSCILLATOR REFERENCE OR RATE OUTPUT CCA REPLACEMENT (AVIM)**

---

12.62.1. Description

This task covers: Removal. Cleaning. Inspection. Installation.

---

12.62.2. Initial Setup

**Tools:**

Electrical tool kit (item 378, App H)

**Personnel Required:**

68X Armament/Electrical System Repairer  
68X3F Armament/Electrical System Repairer/  
Technical Inspector

**Equipment Conditions:**

<u>Ref</u>	<u>Condition</u>
12.60	Ice detector signal processor CCA stack removed

---

**NOTE**

This task is typical for replacement of probe oscillator reference or rate output CCA.

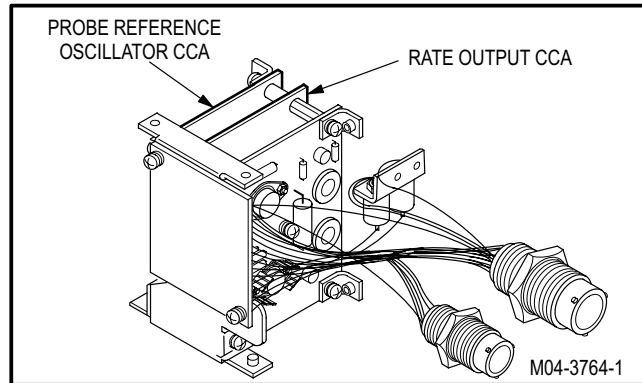

GO TO NEXT PAGE

**12.62. ICE DETECTOR SIGNAL PROCESSOR PROBE OSCILLATOR REFERENCE OR RATE OUTPUT CCA REPLACEMENT (AVIM) - continued**

12.62.3. Removal

a. **Remove two brackets (1) from probe oscillator reference CCA (2).**

- (1) Remove two screws (3), lockwashers (4), and spacers (5) from reference CCA (2).
- (2) Remove two brackets (1).

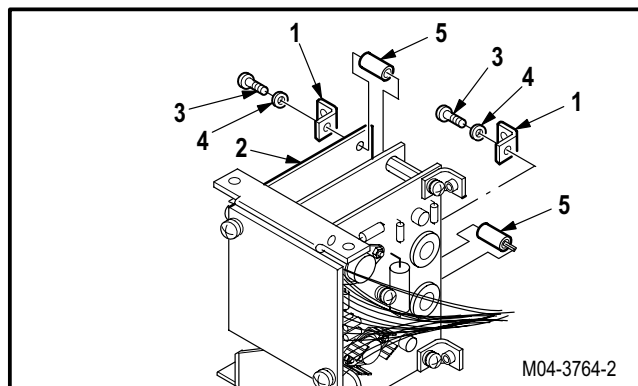

b. **Remove reference CCA (2) or rate output CCA (6).**

- (1) Remove two screws (7), lockwashers (8), and spacers (5) from mounting brackets (9).
- (2) Remove screw (10), lockwasher (11), washer (12), and spacer (5) from reference CCA (2).
- (3) Remove reference CCA (2) or rate output CCA (6) by carefully pulling CCA from interconnection CCA (13). Discard CCA (2) or (6).

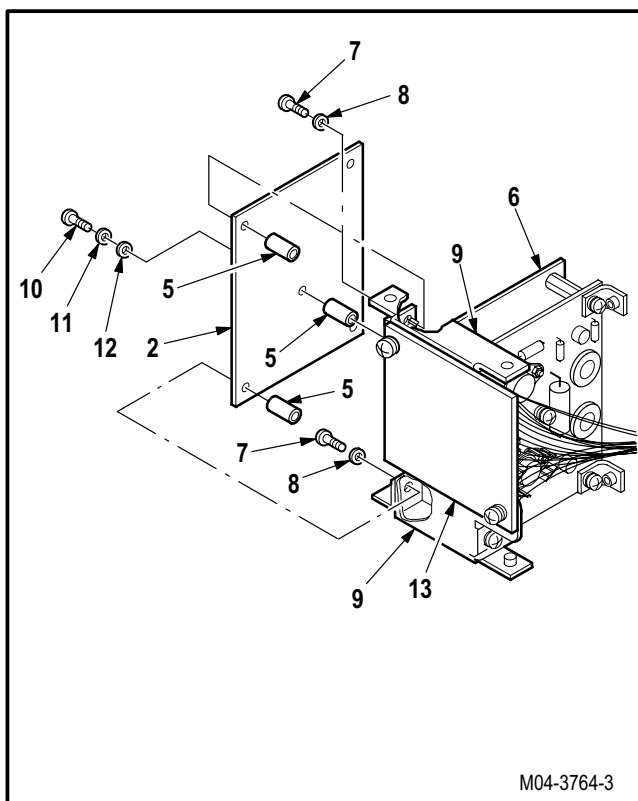

12.62.4. Cleaning

a. **Clean removed and attaching parts** (para 1.47).

12.62.5. Inspection

- a. **Check posts, spacers, brackets, and screws for damage, cracks, and stripped or damaged threads** (para 12.46).
- b. **Check CCA stack components for damage** (para 12.46).

GO TO NEXT PAGE

**12.62. ICE DETECTOR SIGNAL PROCESSOR PROBE OSCILLATOR REFERENCE OR RATE OUTPUT CCA REPLACEMENT (AVIM) - continued**

12.62.6. Installation

**a. Install new reference CCA (2) or rate output CCA (6).**

- (1) Install reference CCA (2) or rate output CCA (6) by carefully mating CCA with interconnection CCA (13).
- (2) Install screw (10) through lockwasher (11), washer (12), reference CCA (2), spacer (5), and rate output CCA (6).
- (3) Install two screws (7) through lockwashers (8), mounting brackets (9), reference CCA (2), spacers (5), and rate output CCA (6).

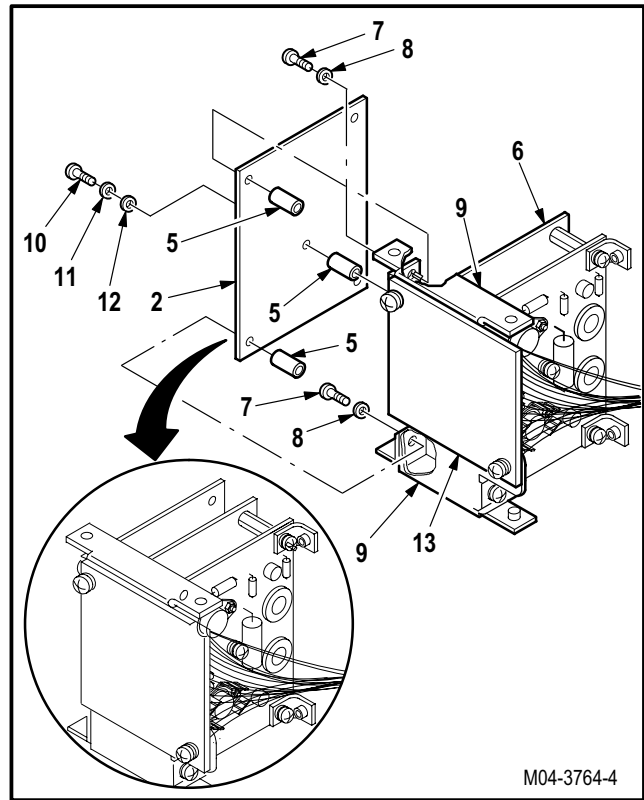

**b. Install two brackets (1) on probe oscillator reference CCA (2).**

- (1) Position brackets (1) on reference CCA (2) as removed.
- (2) Install two screws (3) through lockwashers (4), brackets (1), reference CCA (2), spacers (5), and rate output CCA (6).

**NOTE**

Ensure that brackets are properly aligned to facilitate installation of CCA stack.

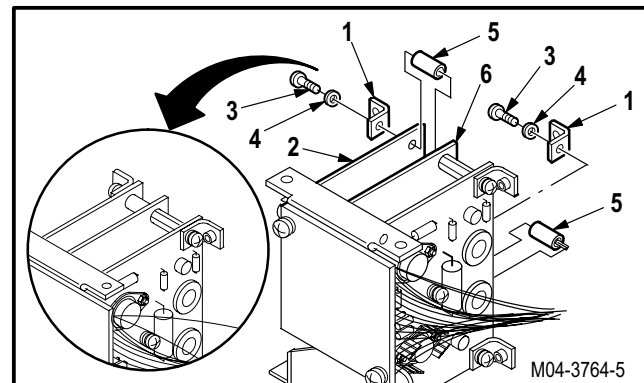

**c. Inspect (QA).**

**d. Install ice detector signal processor CCA stack (para 12.60).**

END OF TASK

**12.63. ICE DETECTOR SIGNAL PROCESSOR POWER SUPPLY CCA REPLACEMENT (AVIM)**

12.63.1. Description

This task covers: Removal. Cleaning. Inspection. Installation.

12.63.2. Initial Setup

**Tools:**

Electrical tool kit (item 378, App H)

**Personnel Required:**

68X Armament/Electrical System Repairer  
 68X3F Armament/Electrical System Repairer/  
 Technical Inspector

**Equipment Conditions:**

<u>Ref</u>	<u>Condition</u>
12.60	Ice detector signal processor CCA stack removed

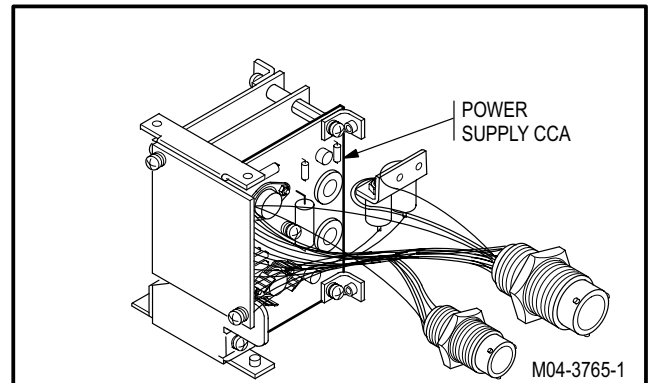

GO TO NEXT PAGE

**12.63. ICE DETECTOR SIGNAL PROCESSOR POWER SUPPLY CCA REPLACEMENT (AVIM) - continued**

12.63.3. Removal

a. **Remove two brackets (1) from power supply CCA (2).**

- (1) Remove two screws (3) and lockwashers (4) from power supply CCA (2).
- (2) Remove two brackets (1).

b. **Remove power supply CCA (2).**

- (1) Remove screw (5) and lockwasher (6) from mounting bracket (7).
- (2) Remove screw (5), lockwasher (6), and ground lead (8) from bracket (9).
- (3) Remove screw (10), lockwasher (11) and washer (12) from power supply CCA (2).
- (4) Remove power supply CCA (2) by carefully pulling CCA from interconnection CCA (13). Discard CCA (2).

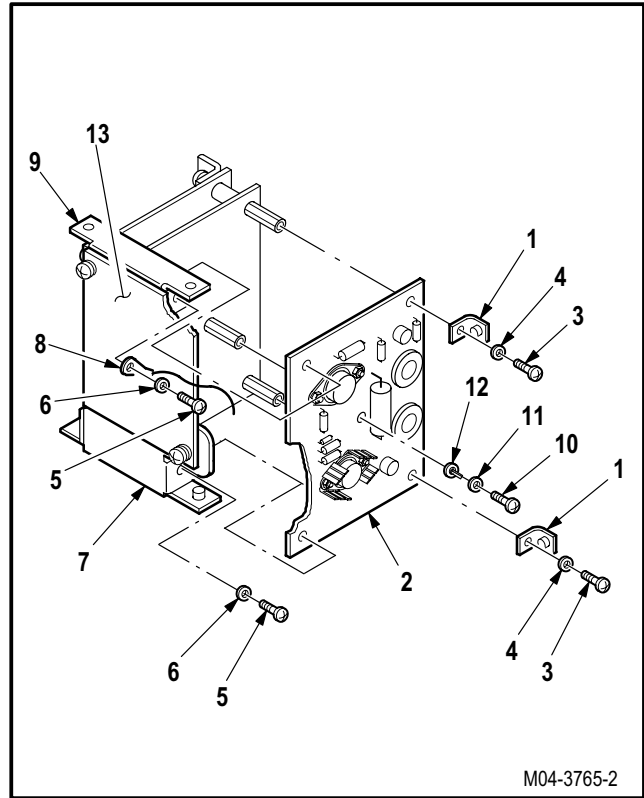

M04-3765-2

12.63.4. Cleaning

a. **Clean removed and attaching parts** (para 1.47).

12.63.5. Inspection

a. **Check posts, spacers, brackets, and screws for damage, cracks, and stripped or damaged threads** (para 12.46).

b. **Check CCA stack components for damage** (para 12.46).

GO TO NEXT PAGE

**12.63. ICE DETECTOR SIGNAL PROCESSOR POWER SUPPLY CCA REPLACEMENT (AVIM) - continued**12.63.6. Installation**a. Install new power supply CCA (2).**

- (1) Install power supply CCA (2) by carefully mating CCA (2) with interconnection CCA (13).
- (2) Install screw (10) through lockwasher (11), washer (12), and power supply CCA (2).
- (3) Install screw (5) through lockwasher (6), ground lead (8), mounting bracket (9), and power supply CCA (2).
- (4) Install screw (5) through lockwasher (6), mounting bracket (7), and power supply CCA (2).

**b. Install two brackets (1) on power supply CCA (2).**

- (1) Position brackets (1) on power supply CCA (2) as removed.
- (2) Install two screws (3) through lockwashers (4), brackets (1), and power supply CCA (2).

**NOTE**

Ensure that brackets are properly aligned to facilitate installation of CCA stack.

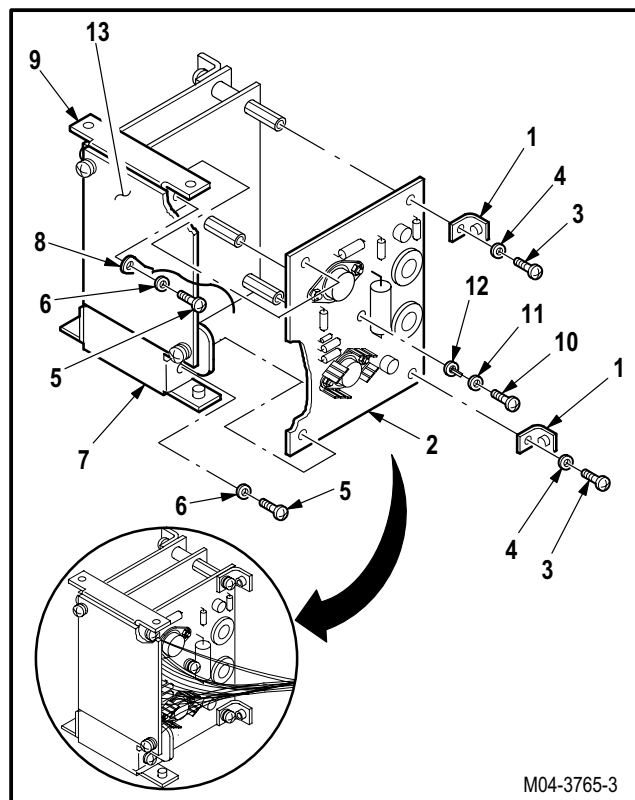
**c. Inspect (QA).****d. Install ice detector signal processor CCA stack (para 12.60).**

END OF TASK

---

## 12.64. ICE DETECTOR SIGNAL PROCESSOR EMI FILTER REPLACEMENT (AVIM)

---

### 12.64.1. Description

This task covers: Removal. Cleaning. Inspection. Installation.

---

### 12.64.2. Initial Setup

#### **Tools:**

Electrical tool kit (item 378, App H)  
Light duty laboratory apron (item 27, App H)  
Chemical protective gloves (item 154, App H)  
Adjustable air filtering respirator (item 262, App H)  
Soldering gun (item 334, App H)

#### **Materials/Parts:**

Solder (item 189, App F)

#### **Personnel Required:**

68X Armament/Electrical System Repairer  
68X3F Armament/Electrical System Repairer/  
Technical Inspector

#### **References:**

TM 55-1500-323-24

#### **Equipment Conditions:**

<u>Ref</u>	<u>Condition</u>
12.60	Ice detector signal processor CCA stack removed

---

### **NOTE**

This task is typical for replacement of EMI filters FL1 or FL2.

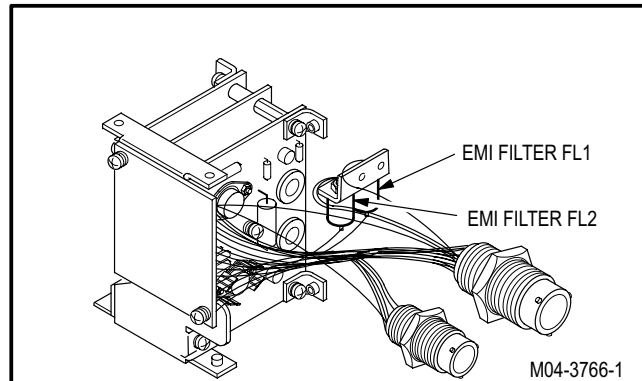

GO TO NEXT PAGE



---

**12.64. ICE DETECTOR SIGNAL PROCESSOR EMI FILTER REPLACEMENT (AVIM) - continued**

---

**12.64.3. Removal**

**WARNING**

**Soldering gun can cause severe burns to personnel and start fires. Observe all safety precautions when using soldering gun. If injury occurs, seek medical aid.**

- a. **Identify and desolder wires (1) from EMI filter (2).** Use soldering gun (TM 55-1500-323-24).
- b. **Remove EMI filter (2) from mounting bracket (3).**

- (1) Hold EMI filter (2). Remove nut (4) and lock-washer (5).

- (2) Remove and discard filter (2).

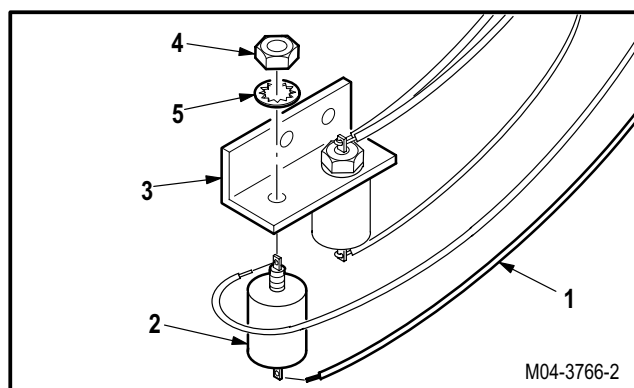
**12.64.4. Cleaning**

- a. **Clean removed and attaching parts** (para 1.47).

**12.64.5. Inspection**

- a. **Check EMI filters and bracket for damage.**  
None allowed.

GO TO NEXT PAGE

---

**12.64. ICE DETECTOR SIGNAL PROCESSOR EMI FILTER REPLACEMENT (AVIM) - continued**

---

12.64.6. Installation

a. **Install new EMI filter (2) on mounting bracket (3).**

- (1) Hold EMI filter (2).
- (2) Install lockwasher (5) and nut (4).



**WARNING**

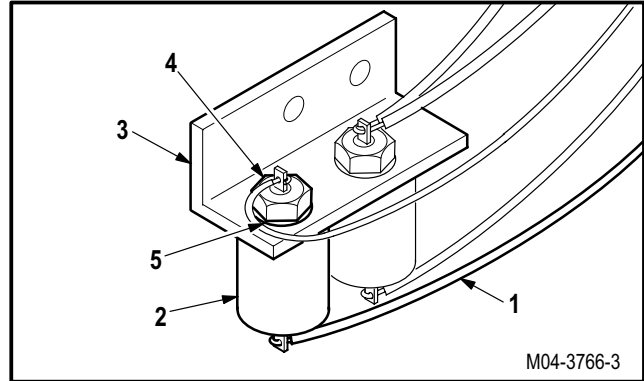

**Soldering gun can cause severe burns to personnel and start fires. Observe all safety precautions when using soldering gun. If injury occurs, seek medical aid.**

- b. **Solder identified wires (1) to EMI filter (2).** Use soldering gun and solder (item 189, App F) (TM 55-1500-323-24).
- c. **Inspect (QA).**
- d. **Install ice detector signal processor CCA stack** (para 12.60).

END OF TASK

**12.65. ICE DETECTOR SENSOR REMOVAL/INSTALLATION**

12.65.1. Description

This task covers: Removal. Cleaning. Inspection. Installation.

12.65.2. Initial Setup

**Tools:**

Aircraft mechanic's tool kit (item 376, App H)

**References:**

TM 1-1520-238-T

**Materials/Parts:**

Damping fluid (item 69, App F)

**Personnel Required:**

67R Attack Helicopter Repairer  
 67R3F Attack Helicopter Repairer/Technical Inspector

**Equipment Conditions:**

Ref	Condition
1.57	Helicopter safed

12.65.3. Removal

- a. Remove warm air supply tube (1) from reducer (2).

(1) Hold reducer (2). Remove nut (3).

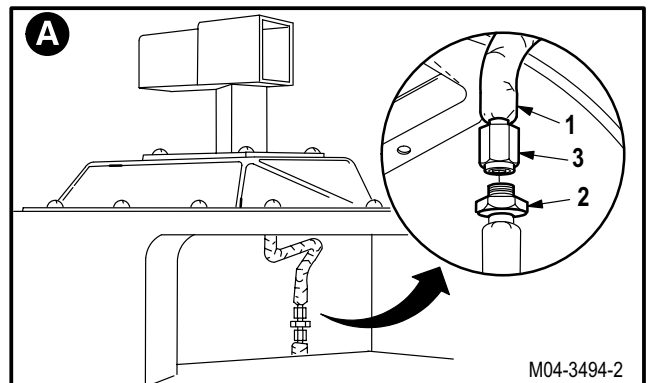
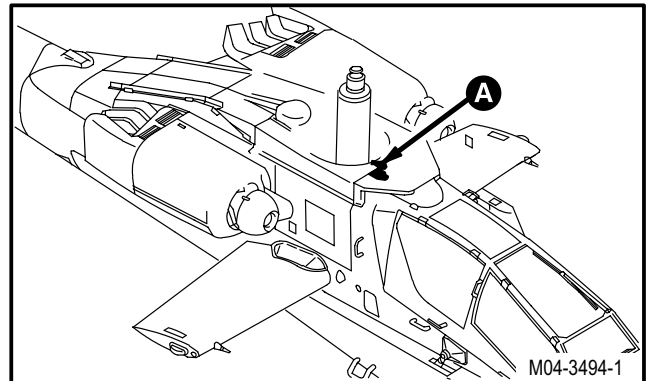

GO TO NEXT PAGE

**12.65. ICE DETECTOR SENSOR REMOVAL/INSTALLATION - continued**

**b. Remove fairing support (4).**

- (1) Remove nine screws (5) and washers (6).
- (2) Remove fairing support (4).

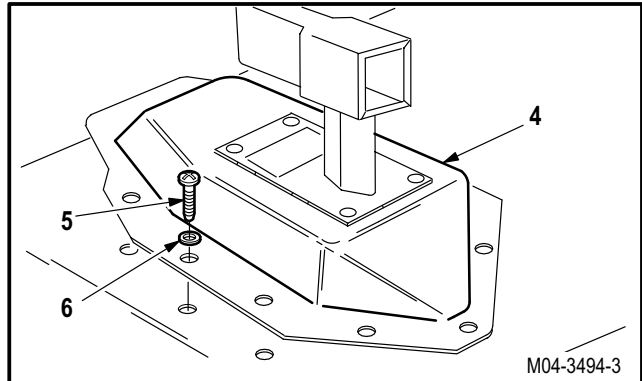

**c. Detach connector P690 (7) from receptacle (A695)J1 (8).**

**d. Remove tube (1) from union (9).**

- (1) Hold union (9). Remove nut (10).

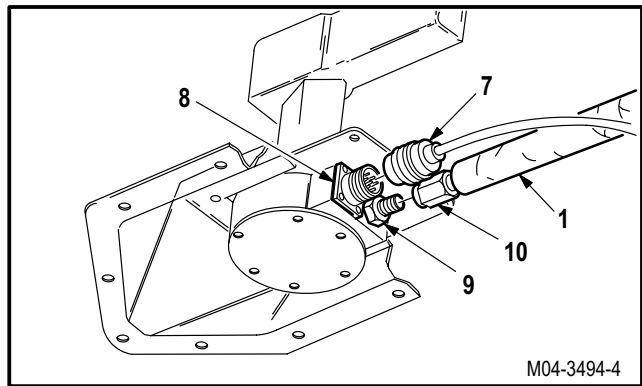

**e. Remove sensor (11) from fairing support (4).**

- (1) Remove four screws (12) and washers (13).
- (2) Remove sensor (11).

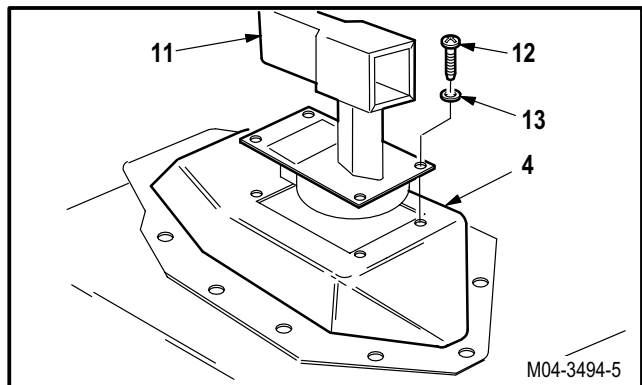

**12.65.4. Cleaning**

**a. Wipe removed and attaching parts with a clean rag.**

**12.65.5. Inspection**

- a. **Check connectors and fittings for stripped or damaged threads** (para 12.46).
- b. **Check ice detector sensor for dents or cracks** (para 12.46).
- c. **Check fairing supports for cracks** (para 12.46).
- d. **Check removed and attaching parts for corrosion** (para 1.49).

GO TO NEXT PAGE

**12.65. ICE DETECTOR SENSOR REMOVAL/INSTALLATION - continued**

12.65.6. Installation

**a. Install sensor (11) on fairing support (4).**

- (1) Position sensor (11) on fairing support (4) and align four screw holes.
- (2) Install four screws (12) and washers (13).

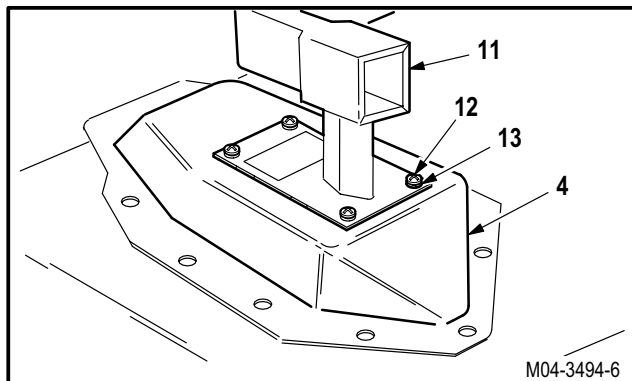

**b. Install tube (1) on union (9).**

- (1) Lubricate threads of union (9). Use damping fluid (item 69, App F).
- (2) Hold union (9). Install nut (10).

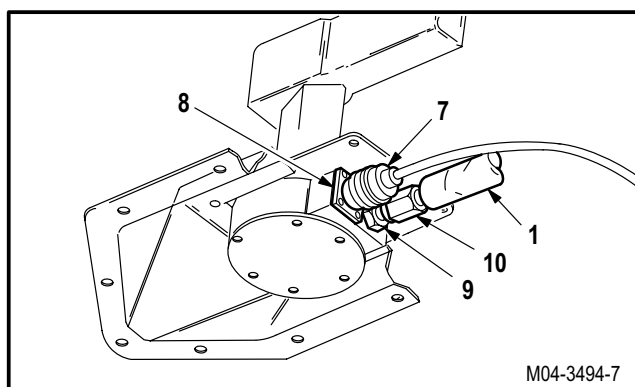

**c. Attach connector P690 (7) to receptacle (A695)J1 (8).**

**d. Install fairing support (4).**

- (1) Position fairing support (4) on fairing (14) and align nine screw holes.
- (2) Install nine screws (5) and washers (6).

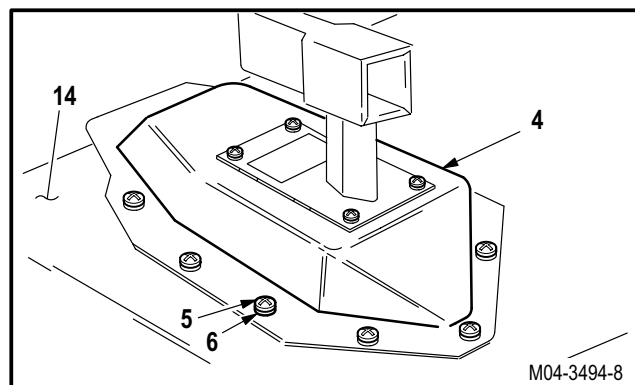

**e. Install tube (1) on reducer (2).**

- (1) Lubricate threads of reducer (2). Use damping fluid (item 69, App F).
- (2) Hold reducer (2). Install nut (3).

**f. Inspect (QA).**

**g. Perform rotor blades de-ice maintenance operational check (TM 1-1520-238-T).**

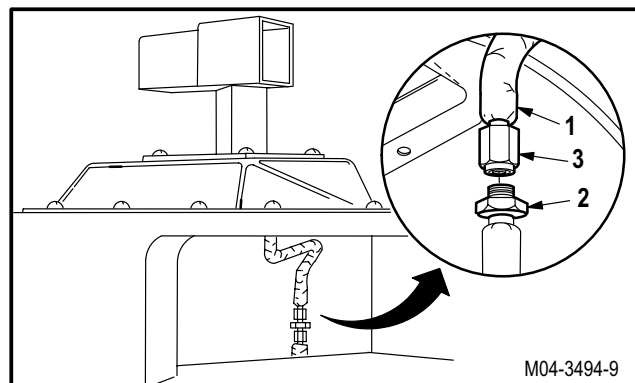

END OF TASK

**12.66. WINDSHIELD ANTI-ICE TEMPERATURE CONTROL BOX REMOVAL/INSTALLATION**

12.66.1. Description

This task covers: Removal. Cleaning. Inspection. Installation.

12.66.2. Initial Setup

**Tools:**

Aircraft mechanic's tool kit (item 376, App H)

**References:**

TM 1-1520-238-T  
 TM 11-1520-238-23-1

**Equipment Conditions:**

<u>Ref</u>	<u>Condition</u>
1.57	Helicopter safed
2.2	CPG access panels CL5 and CL7 removed
TM 11-1520-238-23-1	CPG foot switch removed

**Personnel Required:**

67R Attack Helicopter Repairer  
 67R3F Attack Helicopter Repairer/Technical Inspector

12.66.3. Removal

- a. **Enter CPG station** (para 1.56). **Observe all safety precautions.**
- b. **On pilot aft circuit breaker panel, open ECS CANOPY ANTI-ICE circuit breaker.**

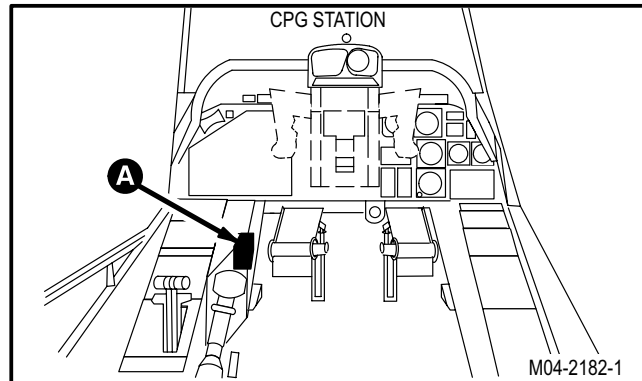

- c. **Remove temperature control box (1) from support (2).**

- (1) Remove four screws (3) and washers (4).
- (2) Detach connector P292 (5) from receptacle (A48)J1 (6).
- (3) Detach connector P291 (7) from receptacle (A48)J2 (8).
- (4) Remove control box (1).

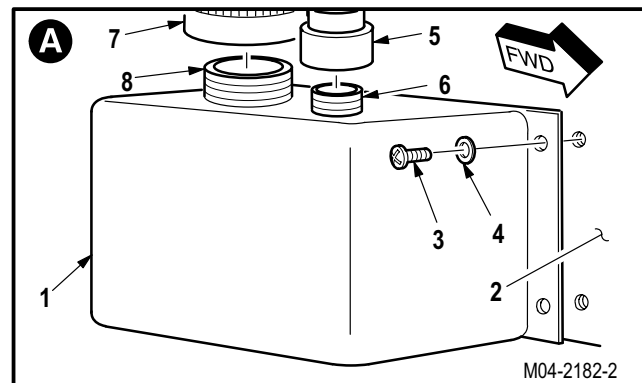

GO TO NEXT PAGE

---

**12.66. WINDSHIELD ANTI-ICE TEMPERATURE CONTROL BOX REMOVAL/INSTALLATION - continued**

---

12.66.4. Cleaning

- a. **Wipe removed and attaching parts with a clean rag.**

12.66.5. Inspection

- a. **Check connectors for loose or bent pins** (para 12.46).
- b. **Check removed and attaching parts for corrosion** (para 1.49).

12.66.6. Installation

- a. **Install control box (1) on support (2).**

- (1) Install four screws (3) and washers (4).

- (2) Attach connector P292 (5) to receptacle (A48)J1 (6).

- (3) Attach connector P291 (7) to receptacle (A48)J2 (8).

- b. **Inspect (QA).**

- c. **Perform canopy defog and anti-ice maintenance operational check** (TM 1-1520-238-T).

- d. **Install CPG access panels CL5 and CL7** (para 2.2).

- e. **Install CPG foot switch** (TM 11-1520-238-23-1).

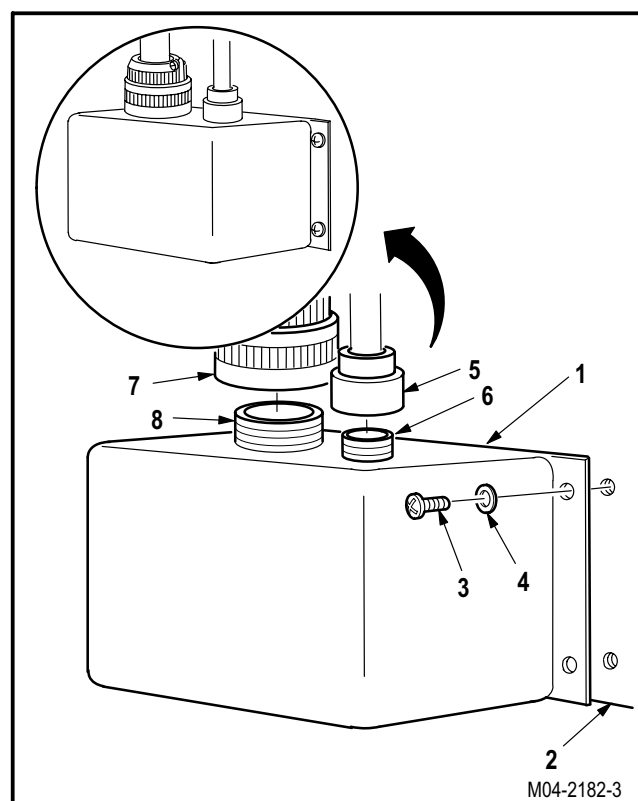

END OF TASK

---

**12.67. WINDSHIELD ANTI-ICE TEMPERATURE CONTROL BOX ACCESS COVER  
REMOVAL/INSTALLATION (AVIM)**

---

12.67.1. Description

This task covers: Removal. Cleaning. Inspection. Installation.

---

12.67.2. Initial Setup

**Tools:**

Electrical tool kit (item 378, App H)

**References:**

TM 11-6625-3085-30

**Personnel Required:**

68X Armament/Electrical System Repairer  
68X3F Armament/Electrical System Repairer/  
Technical Inspector

---

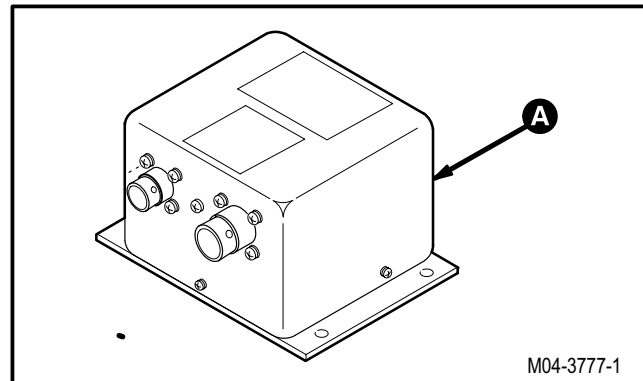

GO TO NEXT PAGE



**12.67. WINDSHIELD ANTI-ICE TEMPERATURE CONTROL BOX ACCESS COVER  
REMOVAL/INSTALLATION (AVIM) - continued**

12.67.3. Removal

**NOTE**

If it is necessary to remove cover to facilitate other maintenance and replacement of cover is not required, perform step a only.

**a. Remove access cover (1) from mounting base (2).**

- (1) Remove three screws (3) and washers (4).
- (2) Remove cover (1).

**b. Remove receptacles (A48)J1 (5) and (A48)J2 (6) from cover (1).**

- (1) Remove eight nuts (7), washers (8), washers (9), and screws (10).
- (2) Remove receptacles (5) and (6).

**c. Remove current transformer (11) from cover (1).**

- (1) Remove nut (12), washer (13), plastic washer (14), slotted washer (15), washer (16), and screw (17).
- (2) Remove transformer (11) and slotted washer (18).

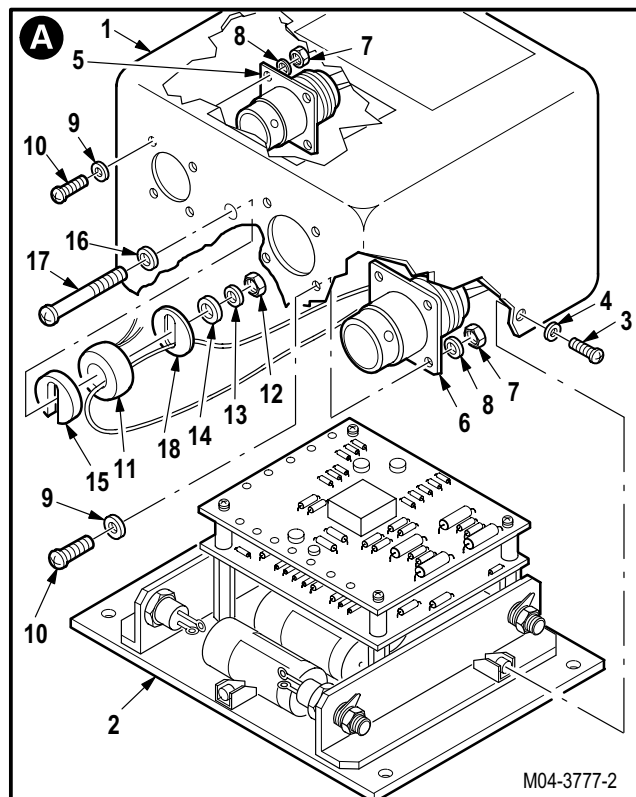

**NOTE**

Transformer and slotted washer will still be attached to a wire running through the center of them.

**d. Remove and discard cover (1).**

GO TO NEXT PAGE

**12.67. WINDSHIELD ANTI-ICE TEMPERATURE CONTROL BOX ACCESS COVER  
REMOVAL/INSTALLATION (AVIM) - continued**

12.67.4. Cleaning

- a. **Clean removed and attaching parts** (para 1.47).

12.67.5. Inspection

- a. **Check removed and attaching parts for damage** (para 12.46).
- b. **Check removed and attaching parts for corrosion** (para 1.49).

12.67.6. Installation

**NOTE**

If cover was removed to facilitate other maintenance, go to step c.

- a. **Install current transformer (11) on new access cover (1).**

- (1) Position transformer (11) on cover (1).
- (2) Run wire (19) through slotted washer (15).
- (3) Install screw (17) through washer (16), cover (1), slotted washer (15), transformer (11), slotted washer (18), plastic washer (14), washer (13), and nut (12).

**CAUTION**

Ensure that wire (19) running through center of slotted washer (18) and transformer (11) is not pinched after tightening assembly.

- b. **Install receptacles (A48)J1 (5) and (A48)J2 (6) on cover (1).**

- (1) Position receptacles (A48)J1 (5) and (A48)J2 (6) on cover (1).
- (2) Install eight screws (10) through washers (9), cover (1), receptacles (5) and (6), washers (8), and nuts (7).

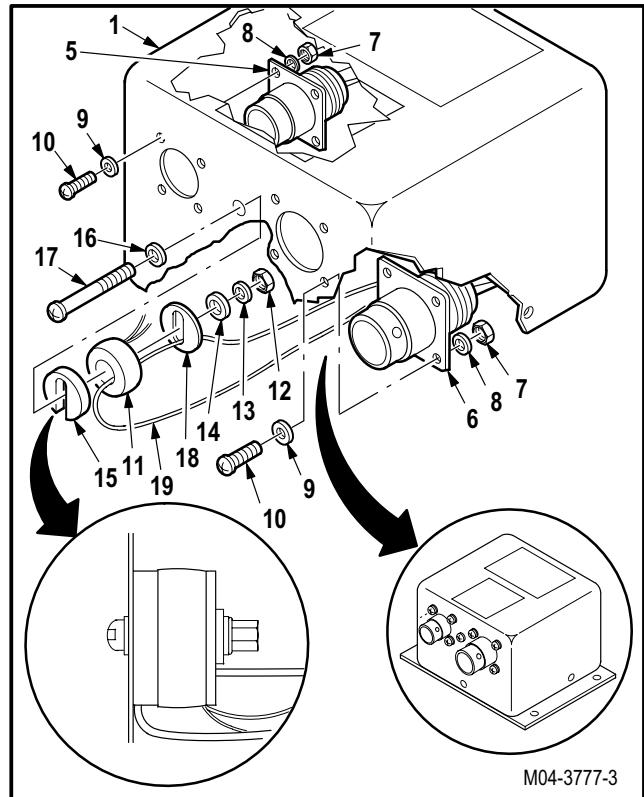

M04-3777-3

GO TO NEXT PAGE

---

**12.67. WINDSHIELD ANTI-ICE TEMPERATURE CONTROL BOX ACCESS COVER  
REMOVAL/INSTALLATION (AVIM) - continued**

---

**c. Install cover (1) on mounting base (2).**

(1) Position cover (1) on base (2).

(2) Install three screws (3) and washers (4).

**d. Inspect (QA).**

e. **Perform appropriate test.** Use Electronic Equipment Test Facility (EETF) (TM 11-6625-3085-30).

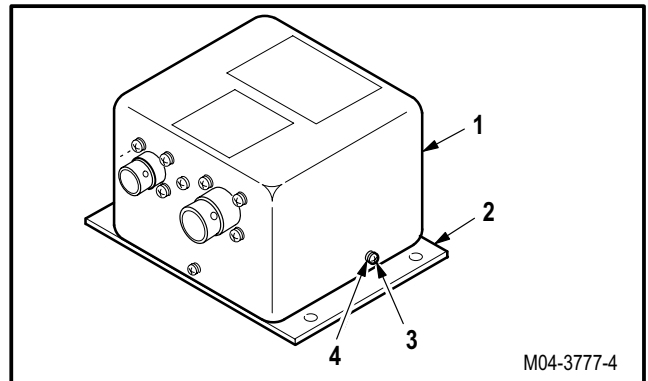

END OF TASK

**12.68. WINDSHIELD ANTI-ICE TEMPERATURE CONTROL BOX CIRCUIT CARD ASSEMBLY (CCA) REMOVAL/INSTALLATION (AVIM)**

12.68.1. Description

This task covers: Removal. Cleaning. Inspection. Installation.

12.68.2. Initial Setup

**Tools:**

- Electrical tool kit (item 378, App H)
- Light duty laboratory apron (item 27, App H)
- Chemical protective gloves (item 154, App H)
- Adjustable air filtering respirator (item 262, App H)
- Soldering gun (item 334, App H)

**Personnel Required:**

- 68X Armament/Electrical System Repairer
- 68X3F Armament/Electrical System Repairer/  
Technical Inspector

**References:**

TM 55-1500-323-24

**Equipment Conditions:**

<u>Ref</u>	<u>Condition</u>
12.67	Windshield anti-ice temperature control box access cover removed

**Materials/Parts:**

Solder (item 189, App F)

**NOTE**

- This task is typical for replacement of CCA A1 or A2.
- If it is necessary to remove CCA(s) to facilitate other maintenance and replacement of CCA(s) is not required, perform step a only.

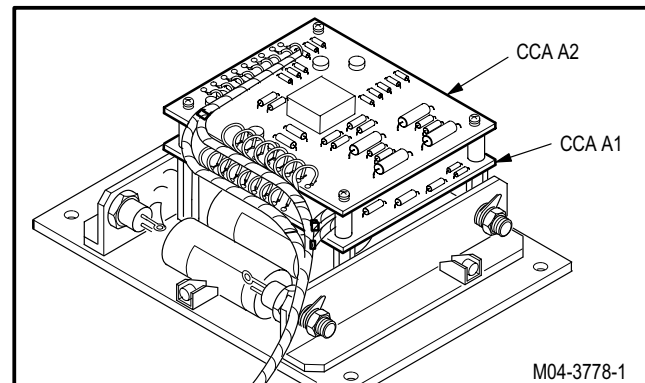

12.68.3. Removal

a. **Remove CCA A1 (1) and A2 (2) from four spacers (3).**

- (1) Remove four screws (4), washers (5), and sleeve spacers (6) from spacers (3).
- (2) Remove CCA A1 (1) and A2 (2).

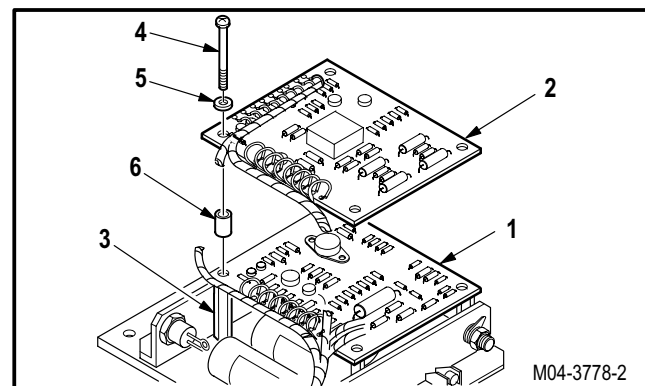

GO TO NEXT PAGE

---

**12.68. WINDSHIELD ANTI-ICE TEMPERATURE CONTROL BOX CIRCUIT CARD ASSEMBLY (CCA)  
REMOVAL/INSTALLATION (AVIM) - continued**

---



**WARNING**

**Soldering gun can cause severe burns to personnel and start fires. Observe all safety precautions when using soldering gun. If injury occurs, seek medical aid.**

- b. **Identify and desolder wires (7) from CCA A1 (1) or A2 (2).** Use soldering gun (TM 55-1500-323-24).
- c. **Remove and discard CCA A1 (1) or A2 (2).**

**12.68.4. Cleaning**

- a. **Clean removed and attaching parts** (para 1.47).

**12.68.5. Inspection**

- a. **Check removed and attaching parts for damage** (para 12.46).

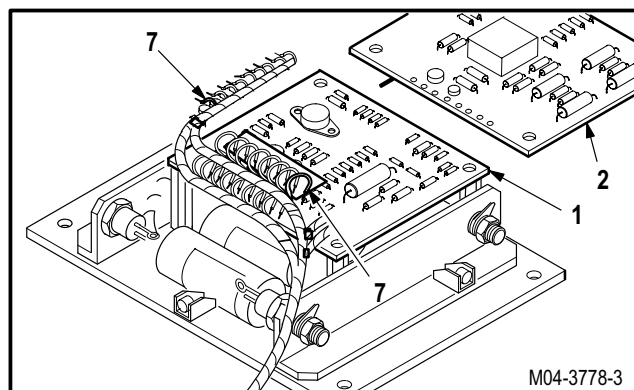

GO TO NEXT PAGE

**12.68. WINDSHIELD ANTI-ICE TEMPERATURE CONTROL BOX CIRCUIT CARD ASSEMBLY (CCA) REMOVAL/INSTALLATION (AVIM) - continued**

12.68.6. Installation



**WARNING**

**Soldering gun can cause severe burns to personnel and start fires. Observe all safety precautions when using soldering gun. If injury occurs, seek medical aid.**

**NOTE**

If CCA(s) were removed to facilitate other maintenance, go to step b.

- a. **Solder identified wires (7) to new CCA A1 (1) or A2 (2).** Use soldering gun and solder (item 189, App F) (TM 55-1500-323-24).

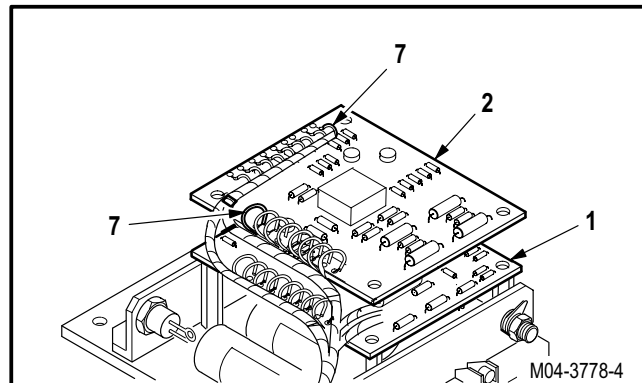

- b. **Install CCA A1 (1) and A2 (2) on four spacers (3).**

- (1) Aline CCA A1 (1) and A2 (2) with four spacers (3).
- (2) Install four screws (4) through washers (5), CCA A2 (2), sleeve spacers (6), and CCA A1 (1) into spacers (3).

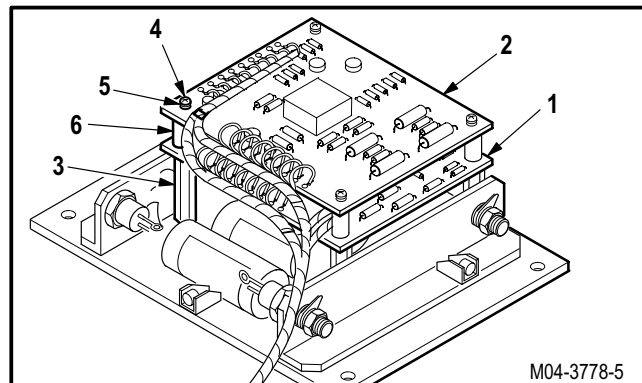

- c. **Inspect (QA).**
- d. **Install windshield anti-ice temperature control box access cover** (para 12.67).

END OF TASK

---

**12.69. WINDSHIELD ANTI-ICE TEMPERATURE CONTROL BOX CAPACITOR REPLACEMENT (AVIM)**

---

12.69.1. Description

This task covers: Removal. Cleaning. Inspection. Installation.

---

12.69.2. Initial Setup

**Tools:**

- Electrical tool kit (item 378, App H)
- Light duty laboratory apron (item 27, App H)
- Chemical protective gloves (item 154, App H)
- Adjustable air filtering respirator (item 262, App H)
- Soldering gun (item 334, App H)

**Personnel Required:**

- 68X Armament/Electrical System Repairer
- 68X3F Armament/Electrical System Repairer/  
Technical Inspector

**References:**

TM 55-1500-323-24

**Equipment Conditions:**

<u>Ref</u>	<u>Condition</u>
12.68	Windshield anti-ice temperature control box CCAs removed

**Materials/Parts:**

- Solder (item 189, App F)
- 

**NOTE**

This task is typical for replacement of capacitor C1, C2, or C3.

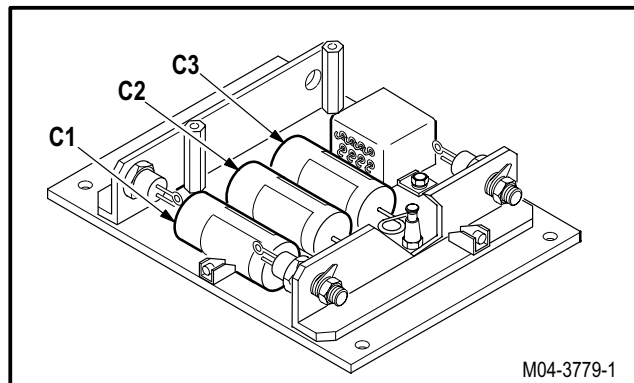

GO TO NEXT PAGE

---

**12.69. WINDSHIELD ANTI-ICE TEMPERATURE CONTROL BOX CAPACITOR REPLACEMENT (AVIM) - continued**

---

12.69.3. Removal



**WARNING**

**Soldering gun can cause severe burns to personnel and start fires. Observe all safety precautions when using soldering gun. If injury occurs, seek medical aid.**

- a. **Desolder capacitor wire (1) from terminal stud (2).** Use soldering gun (TM 55-1500-323-24).
- b. **Remove and discard capacitor (3) from spring clip (4).**

12.69.4. Cleaning

- a. **Clean removed and attaching parts** (para 1.47).

12.69.5. Inspection

- a. **Check removed and attaching parts for damage** (para 12.46).

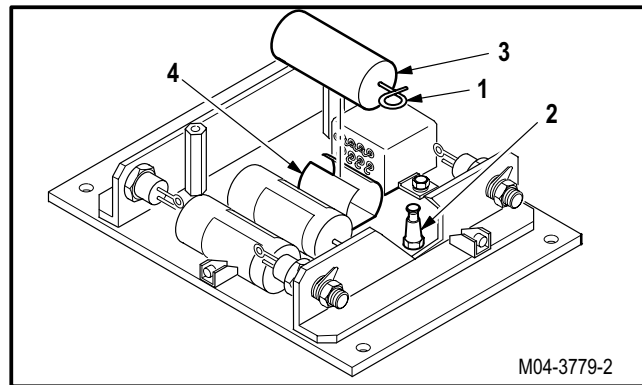

GO TO NEXT PAGE



---

**12.69. WINDSHIELD ANTI-ICE TEMPERATURE CONTROL BOX CAPACITOR REPLACEMENT (AVIM) - continued**



---

12.69.6. Installation

- a. Install new capacitor (3) on spring clip (4).

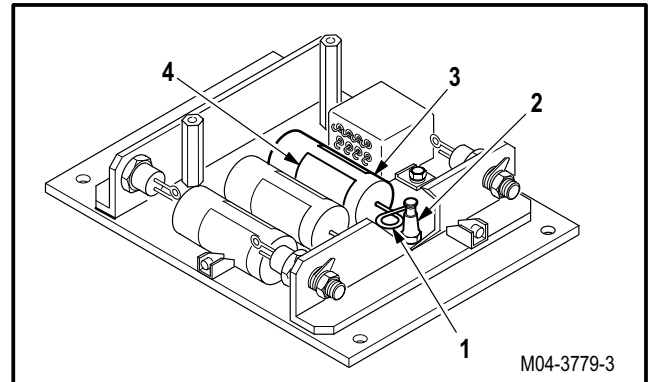

**Soldering gun can cause severe burns to personnel and start fires. Observe all safety precautions when using soldering gun. If injury occurs, seek medical aid.**



- b. **Solder capacitor wire (1) to terminal stud (2).** Use soldering gun and solder (item 189, App F) (TM 55-1500-323-24).
- c. **Inspect (QA).**
- d. **Install windshield anti-ice temperature control box CCAs** (para 12.68).

END OF TASK

---

**12.70. WINDSHIELD ANTI-ICE TEMPERATURE CONTROL BOX RELAY REPLACEMENT (AVIM)**

---

12.70.1. Description

This task covers: Removal. Cleaning. Inspection. Installation.

---

12.70.2. Initial Setup

**Tools:**

- Electrical tool kit (item 378, App H)
- Light duty laboratory apron (item 27, App H)
- Chemical protective gloves (item 154, App H)
- Adjustable air filtering respirator (item 262, App H)
- Soldering gun (item 334, App H)

**Personnel Required:**

- 68X Armament/Electrical System Repairer
- 68X3F Armament/Electrical System Repairer/  
Technical Inspector

**References:**

TM 55-1500-323-24

**Equipment Conditions:**

<u>Ref</u>	<u>Condition</u>
12.68	Windshield anti-ice temperature control box CCAs removed

**Materials/Parts:**

- Solder (item 189, App F)
- 

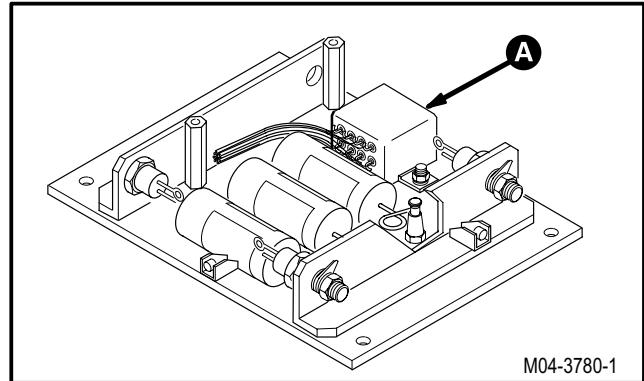

12.70.3. Removal

- a. **Remove relay (1) from mounting base studs (2).**

- (1) Remove two nuts (3) and washers (4).
- (2) Remove relay (1).

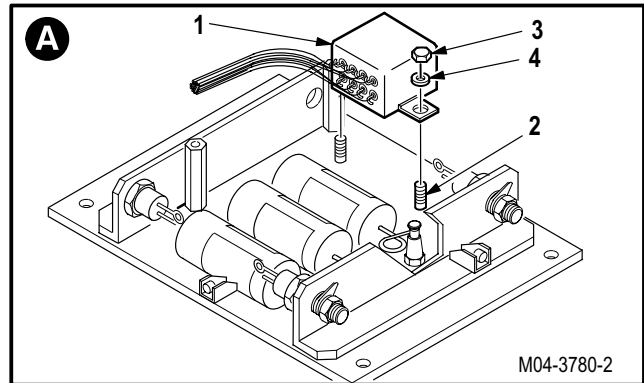

GO TO NEXT PAGE

---

**12.70. WINDSHIELD ANTI-ICE TEMPERATURE CONTROL BOX RELAY REPLACEMENT (AVIM) - continued**

---

**WARNING**

Soldering gun can cause severe burns to personnel and start fires. Observe all safety precautions when using soldering gun. If injury occurs, seek medical aid.

- b. **Identify and desolder wires (5) from relay terminals (6).** Use soldering gun (TM 55-1500-323-24).
- c. **Remove and discard relay (1).**

**12.70.4. Cleaning**

- a. **Clean removed and attaching parts** (para 1.47).

**12.70.5. Inspection**

- a. **Check removed and attaching parts for damage** (para 12.46).

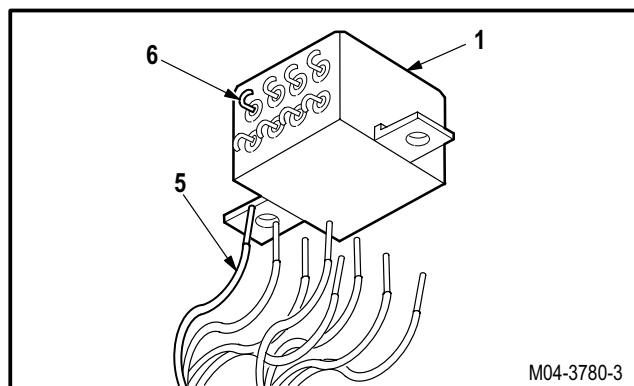

GO TO NEXT PAGE

**12.70. WINDSHIELD ANTI-ICE TEMPERATURE CONTROL BOX RELAY REPLACEMENT (AVIM) - continued**

12.70.6. Installation



**WARNING**

**Soldering gun can cause severe burns to personnel and start fires. Observe all safety precautions when using soldering gun. If injury occurs, seek medical aid.**

- a. **Solder identified wires (5) to new relay terminals (6).** Use soldering gun and solder (item 189, App F) (TM 55-1500-323-24).

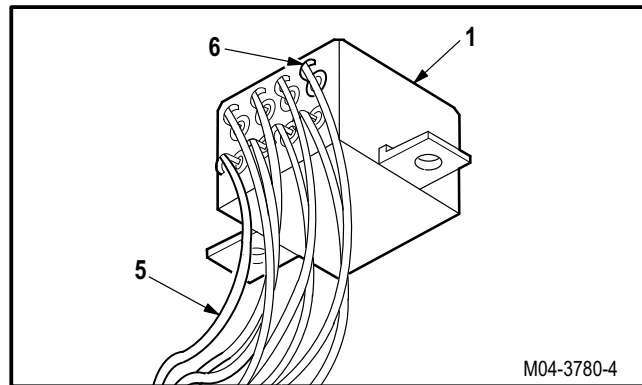

- b. **Install relay (1) on mounting base studs (2).**

- (1) Position relay (1) on studs (2).
- (2) Install two washers (4) and nuts (3).

- c. **Inspect (QA).**

- d. **Install windshield anti-ice temperature control box CCAs** (para 12.68).

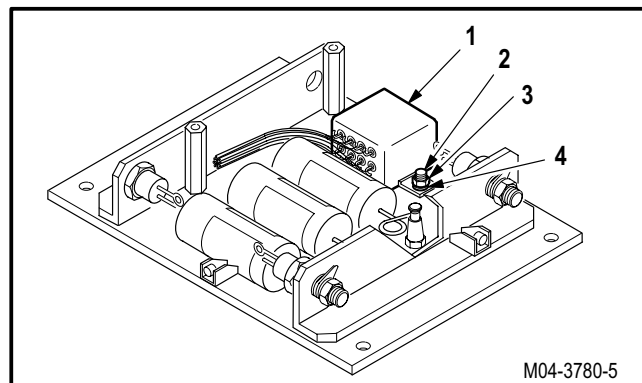

END OF TASK

---

**12.71. WINDSHIELD ANTI-ICE TEMPERATURE CONTROL BOX SEMICONDUCTOR REPLACEMENT (AVIM)**

---

12.71.1. Description

This task covers: Removal. Cleaning. Inspection. Installation.

---

12.71.2. Initial Setup

**Tools:**

- Electrical tool kit (item 378, App H)
- Light duty laboratory apron (item 27, App H)
- Chemical protective gloves (item 154, App H)
- Adjustable air filtering respirator (item 262, App H)
- Soldering gun (item 334, App H)

**Personnel Required:**

- 68X Armament/Electrical System Repairer
- 68X3F Armament/Electrical System Repairer/  
Technical Inspector

**References:**

TM 55-1500-323-24

**Equipment Conditions:**

<u>Ref</u>	<u>Condition</u>
12.68	Windshield anti-ice temperature control box CCAs removed

**Materials/Parts:**

- Solder (item 189, App F)
- 

**NOTE**

This task is typical for replacement of semiconductor's Q1, Q2, Q3, and Q4.

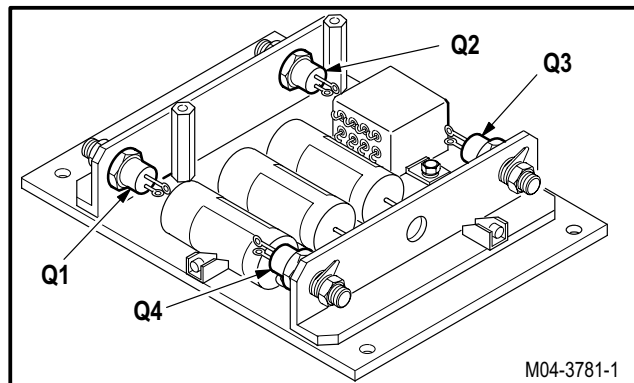

GO TO NEXT PAGE

**12.71. WINDSHIELD ANTI-ICE TEMPERATURE CONTROL BOX SEMICONDUCTOR REPLACEMENT (AVIM) - continued**

12.71.3. Removal

a. **Remove semiconductor (1) from mounting bracket (2).**

(1) Hold semiconductor (1). Remove nut (3), lockwasher (4), two washers (5), terminal lug (6), insulator washer (7), and tubing (8) from semiconductor (1).

(2) Remove semiconductor (1) and insulator washer (7).

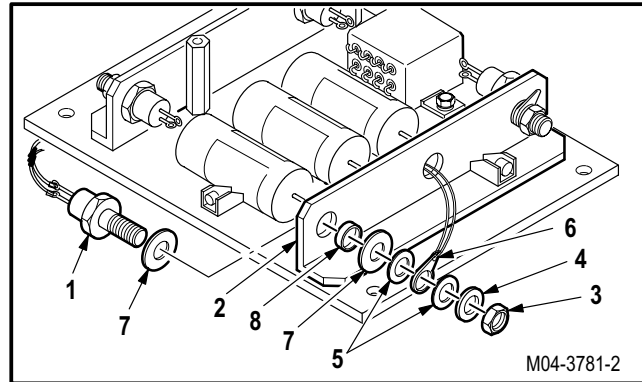

**WARNING**

**Soldering gun can cause severe burns to personnel and start fires. Observe all safety precautions when using soldering gun. If injury occurs, seek medical aid.**

b. **Identify and desolder wires (9) from semiconductor terminals (10).** Use soldering gun (TM 55-1500-323-24).

c. **Remove and discard semiconductor (1).**

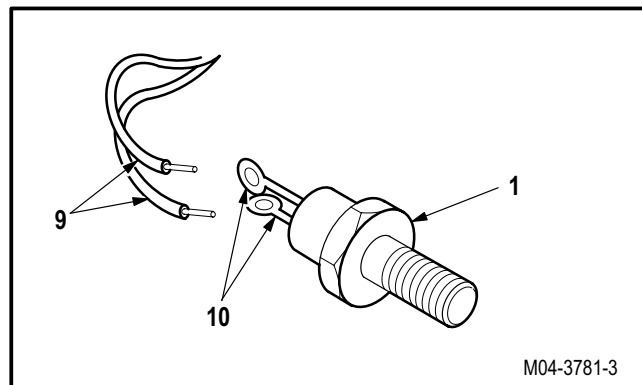

12.71.4. Cleaning

a. **Clean removed and attaching parts** (para 1.47).

12.71.5. Inspection

a. **Check removed and attaching parts for damage** (para 12.46).

GO TO NEXT PAGE

**12.71. WINDSHIELD ANTI-ICE TEMPERATURE CONTROL BOX SEMICONDUCTOR REPLACEMENT (AVIM) - continued**

12.71.6. Installation



**WARNING**

**Soldering gun can cause severe burns to personnel and start fires. Observe all safety precautions when using soldering gun. If injury occurs, seek medical aid.**

a. **Solder identified wires (9) to new semiconductor terminals (10).** Use soldering gun and solder (item 189, App F) (TM 55-1500-323-24).

b. **Install semiconductor (1) on mounting bracket (2).**

(1) Install insulator washer (7) on semiconductor (1).

(2) Install semiconductor (1) on mounting bracket (2).

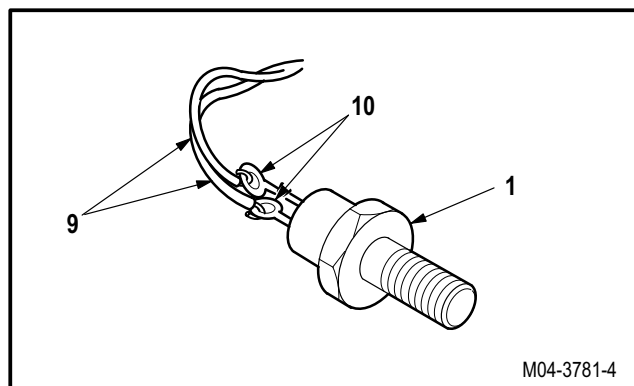

**NOTE**

Ensure that after installation, terminal lug does not interfere with other components in control box.

(3) Install tubing (8), insulator washer (7), washer (5), terminal lug (6), washer (5), and lock-washer (4) on semiconductor (1).

(4) Hold semiconductor (1). Install nut (3).

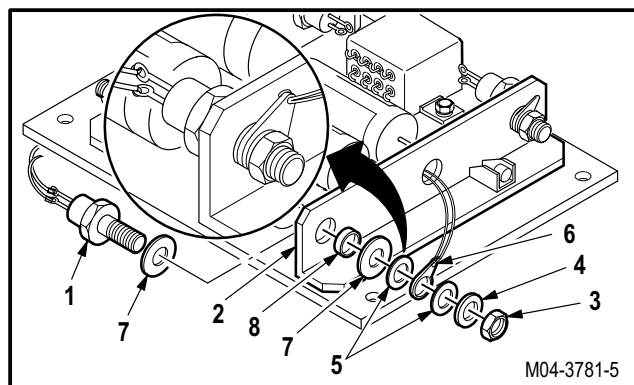

c. **Inspect (QA).**

d. **Install windshield anti-ice temperature control box CCAs** (para 12.68).

END OF TASK

---

**12.72. WINDSHIELD ANTI-ICE TEMPERATURE CONTROL BOX CURRENT TRANSFORMER REPLACEMENT (AVIM)**

---

12.72.1. Description

This task covers: Removal. Cleaning. Inspection. Installation.

---

12.72.2. Initial Setup

**Tools:**

Electrical tool kit (item 378, App H)  
Light duty laboratory apron (item 27, App H)  
Chemical protective gloves (item 154, App H)  
Adjustable air filtering respirator (item 262, App H)  
Soldering gun (item 334, App H)

**Personnel Required:**

68X Armament/Electrical System Repairer  
68X3F Armament/Electrical System Repairer/  
Technical Inspector

**References:**

TM 55-1500-323-24

**Equipment Conditions:**

<u>Ref</u>	<u>Condition</u>
12.67	Windshield anti-ice temperature control box access cover removed

**Materials/Parts:**

Solder (item 189, App F)

---

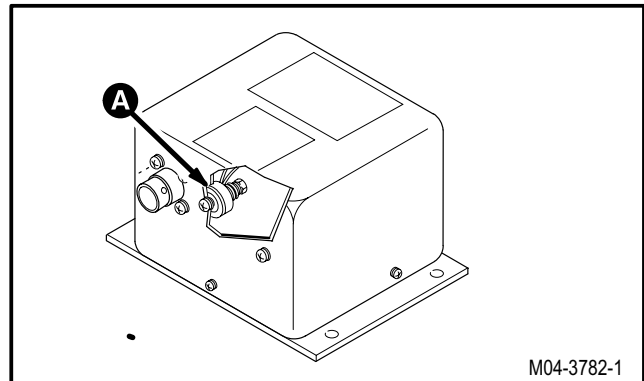

GO TO NEXT PAGE



**12.72. WINDSHIELD ANTI-ICE TEMPERATURE CONTROL BOX CURRENT TRANSFORMER REPLACEMENT (AVIM) - continued**

12.72.3. Removal

a. **Remove current transformer (1) from access cover (2).**

- (1) Remove nut (3), washer (4), plastic washer (5), slotted washer (6), washer (7), and screw (8).

**NOTE**

Transformer and slotted washer will still be attached to the wire running through the center of them.

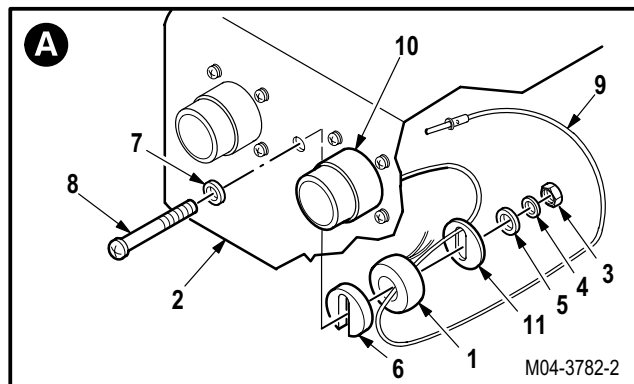

- (2) Identify and depin one end of wire (9) from receptacle (A48)J2 (10) (TM 55-1500-323-24).

- (3) Remove transformer (1) and slotted washer (11) from wire (9).



**WARNING**

**Soldering gun can cause severe burns to personnel and start fires. Observe all safety precautions when using soldering gun. If injury occurs, seek medical aid.**

- b. **Identify and desolder transformer wires (12) from CCA A2 terminals (13).** Use soldering gun (TM 55-1500-323-24).

- c. **Remove and discard transformer (1).**

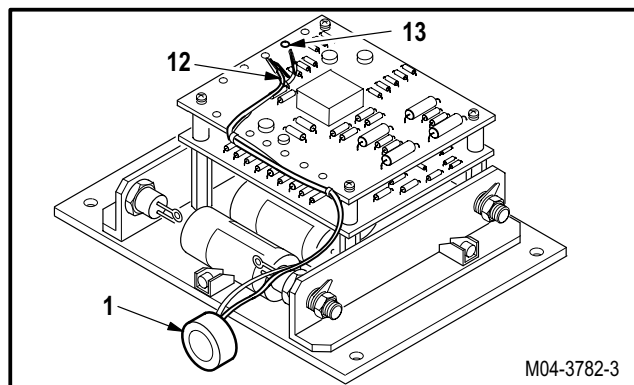

GO TO NEXT PAGE

---

**12.72. WINDSHIELD ANTI-ICE TEMPERATURE CONTROL BOX CURRENT TRANSFORMER REPLACEMENT (AVIM) - continued**

---

12.72.4. Cleaning

- a. **Clean removed and attaching parts** (para 1.47).

12.72.5. Inspection

- a. **Check removed and attaching parts for damage** (para 12.46).

12.72.6. Installation



**WARNING**

**Soldering gun can cause severe burns to personnel and start fires. Observe all safety precautions when using soldering gun. If injury occurs, seek medical aid.**

- a. **Solder identified transformer wires (12) to CCA A2 terminals (13).** Use soldering gun and solder (item 189, App F) (TM 55-1500-323-24).

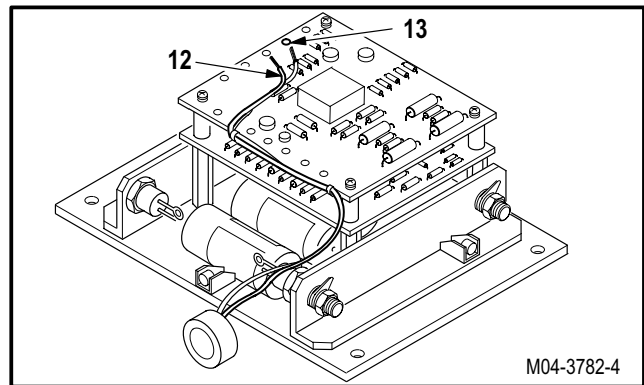

GO TO NEXT PAGE

---

**12.72. WINDSHIELD ANTI-ICE TEMPERATURE CONTROL BOX CURRENT TRANSFORMER REPLACEMENT (AVIM) - continued**

---

**NOTE**

Ensure that transformer wires are installed on the inboard side of control box.

**b. Install new current transformer (1) on access cover (2).**

- (1) Insert wire (9) through transformer (1) and slotted washer (11).
- (2) Pin identified wire (9) in receptacle (A48)J2 (10) (TM 55-1500-323-24).
- (3) Position transformer (1) on cover (2).
- (4) Run wire (9) through slotted washer (6).
- (5) Install screw (8) through washer (7), cover (2), slotted washer (6), transformer (1), slotted washer (11), plastic washer (5), washer (4), and nut (3).

**CAUTION**

Ensure wire (9) running through center of slotted washer (11) and transformer (1) is not pinched after tightening assembly.

**c. Inspect (QA).**

**d. Install windshield anti-ice temperature control box access cover (para 12.67).**

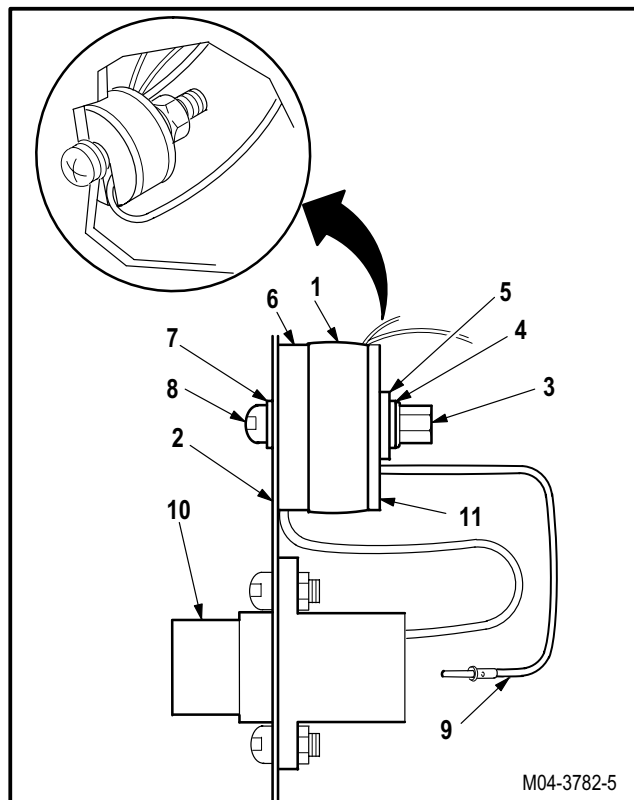

END OF TASK

---

**12.73. WINDSHIELD ANTI-ICE TEMPERATURE CONTROL BOX RECEPTACLE REPLACEMENT (AVIM)**

---

12.73.1. Description

This task covers: Removal. Cleaning. Inspection. Installation.

---

12.73.2. Initial Setup

**Tools:**

Electrical tool kit (item 378, App H)

**References:**

TM 55-1500-323-24

**Personnel Required:**

68X Armament/Electrical System Repairer  
 68X3F Armament/Electrical System Repairer/  
 Technical Inspector

**Equipment Conditions:**

<u>Ref</u>	<u>Condition</u>
12.67	Windshield anti-ice temperature control box access cover removed

**NOTE**

This task is typical for replacement of receptacles (A48)J1 or (A48)J2.

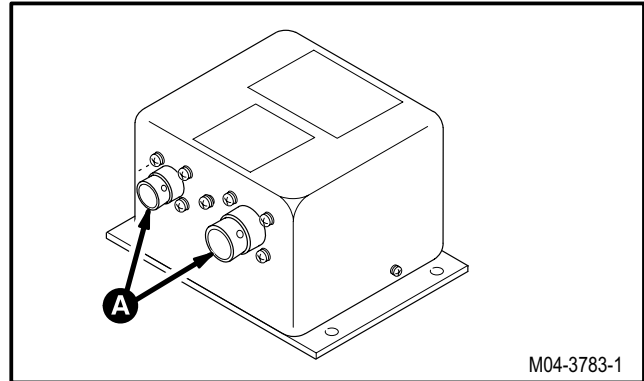

12.73.3. Removal

a. **Remove receptacle (1) from cover (2).**

(1) Remove four nuts (3), washers (4), washers (5), and screws (6).

(2) Remove receptacle (1).

b. **Identify and depin wires (7) from receptacle (1)** (TM 55-1500-323-24).

c. **Remove and discard receptacle (1).**

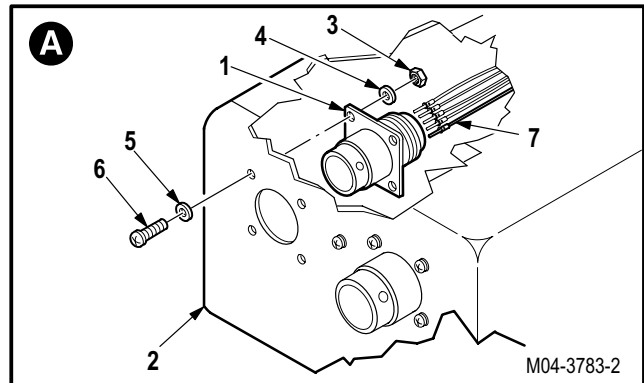

GO TO NEXT PAGE

---

**12.73. WINDSHIELD ANTI-ICE TEMPERATURE CONTROL BOX RECEPTACLE REPLACEMENT (AVIM) - continued**

---

**12.73.4. Cleaning**

- a. **Clean removed and attaching parts** (para 1.47).

**12.73.5. Inspection**

- a. **Check removed and attaching parts for damage** (para 12.46).

**12.73.6. Installation**

- a. **Pin identified wires (7) in new receptacle (1)** (TM 55-1500-323-24).
- b. **Install receptacle (1) on cover (2).**
  - (1) Position receptacle (1) on cover (2).
  - (2) Install four screws (6) through washers (5), cover (2), receptacle (1), washers (4), and nuts (3).
- c. **Inspect (QA).**
- d. **Install windshield anti-ice temperature control box access cover** (para 12.67).

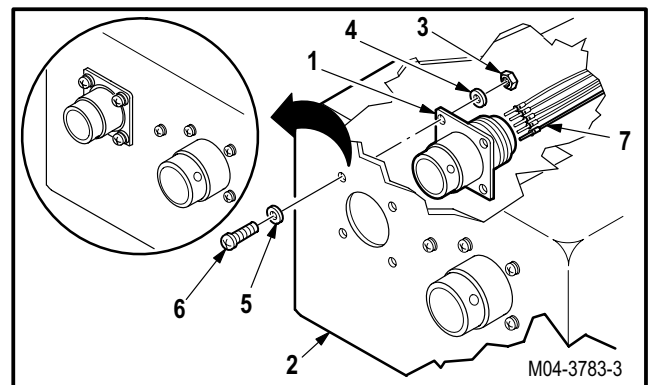

END OF TASK

---

**12.74. WINDSHIELD ANTI-ICE TEMPERATURE CONTROL BOX TERMINAL STUD REPLACEMENT (AVIM)**

---

12.74.1. Description

This task covers: Removal. Cleaning. Inspection. Installation.

---

12.74.2. Initial Setup

**Tools:**

Electrical tool kit (item 378, App H)  
Light duty laboratory apron (item 27, App H)  
Chemical protective gloves (item 154, App H)  
Adjustable air filtering respirator (item 262, App H)  
Soldering gun (item 334, App H)

**Personnel Required:**

68X Armament/Electrical System Repairer  
68X3F Armament/Electrical System Repairer/  
Technical Inspector

**References:**

TM 55-1500-323-24

**Equipment Conditions:**

<u>Ref</u>	<u>Condition</u>
12.68	Windshield anti-ice temperature control box CCAs removed

**Materials/Parts:**

Sealing compound (item 169, App F)  
Solder (item 189, App F)

---

**NOTE**

This task is typical for replacement of terminal studs E1, E2, and E3.

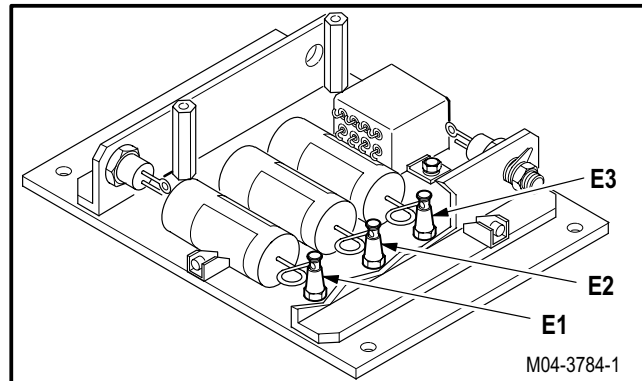

GO TO NEXT PAGE

---

**12.74. WINDSHIELD ANTI-ICE TEMPERATURE CONTROL BOX TERMINAL STUD REPLACEMENT (AVIM) - continued**

---

12.74.3. Removal

**WARNING**

**Soldering gun can cause severe burns to personnel and start fires. Observe all safety precautions when using soldering gun. If injury occurs, seek medical aid.**

- a. **Identify and desolder wires (1) from terminal stud (2). Use soldering gun (TM 55-1500-323-24).**
- b. **Remove and discard terminal stud (2) from mounting base stud (3).**

12.74.4. Cleaning

- a. **Clean removed and attaching parts (para 1.47).**

12.74.5. Inspection

- a. **Check removed and attaching parts for damage (para 12.46).**

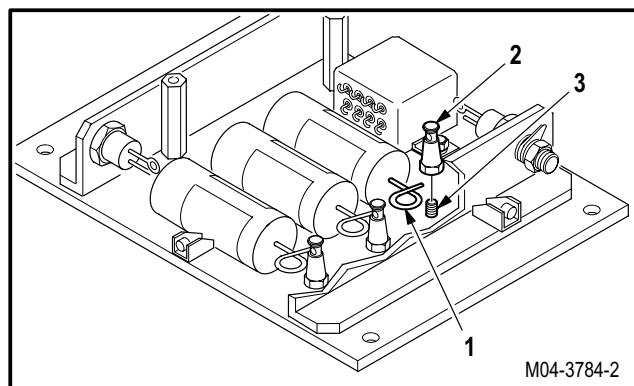

GO TO NEXT PAGE

**12.74. WINDSHIELD ANTI-ICE TEMPERATURE CONTROL BOX TERMINAL STUD REPLACEMENT (AVIM) - continued**

12.74.6. Installation



**a. Install new terminal stud (2) on mounting base stud (3).**

- (1) Apply sealing compound to threads of mounting base stud (2). Use sealing compound (item 169, App F).
- (2) Install terminal stud (2) on mounting base stud (3).

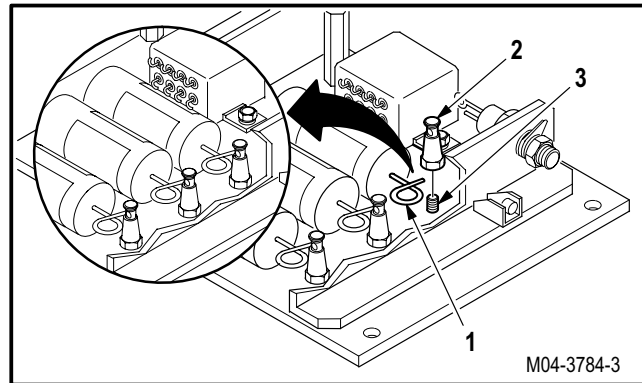

**WARNING**

**Soldering gun can cause severe burns to personnel and start fires. Observe all safety precautions when using soldering gun. If injury occurs, seek medical aid.**

- b. Solder identified wires (1) to terminal stud (2).**  
Use soldering gun and solder (item 189, App F) (TM 55-1500-323-24).
- c. Inspect (QA).**
- d. Install windshield anti-ice temperature control box CCAs** (para 12.68).

END OF TASK



## 12.75. OUTSIDE AIR TEMPERATURE SENSOR REMOVAL/INSTALLATION

### 12.75.1. Description

This task covers: Removal. Cleaning. Inspection. Installation.

### 12.75.2. Initial Setup

#### Tools:

Electrical tool kit (item 378, App H)

#### References:

TM 1-1520-238-T

#### Personnel Required:

68X Armament/Electrical System Repairer  
 68X3F Armament/Electrical System Repairer/  
 Technical Inspector

#### Equipment Conditions:

Ref	Condition
1.57	Helicopter safed
2.2	Access panel R200 removed

### 12.75.3. Removal

#### a. Remove outside air temperature sensor (1) from fairing (2).

- (1) Detach connector P1042 (3) from receptacle (A176)J1 (4).
- (2) Remove four screws (5) and washers (6).
- (3) Remove sensor (1) and gaskets (7).

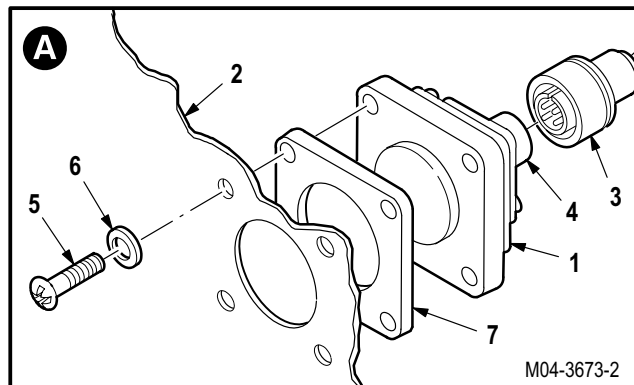
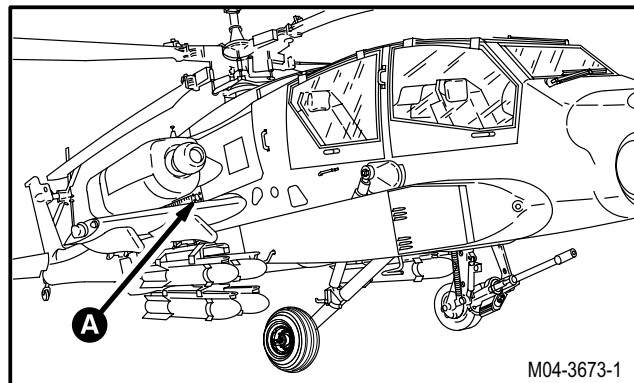

GO TO NEXT PAGE

---

**12.75. OUTSIDE AIR TEMPERATURE SENSOR REMOVAL/INSTALLATION - continued**

---

12.75.4. Cleaning

- a. **Wipe removed and attaching parts with a clean rag.**

12.75.5. Inspection

- a. **Check sensor mounting area for cracks or delaminations** (para 12.46).
- b. **Check removed and attaching parts for corrosion** (para 1.49).

12.75.6. Installation

- a. **Install sensor (1) on fairing (2).**

**NOTE**

Use gaskets as required to bring face of sensor flush with fairing.

- (1) Install gaskets (7) on sensor (1).
  - (2) Position sensor (1) and gaskets (7) on fairing (2).
  - (3) Install four screws (5) and washers (6).
  - (4) Attach connector P1042 (3) to receptacle (A176)J1 (4).
- b. **Inspect (QA).**
  - c. **Perform rotor blades de-ice maintenance operational check** (TM 1-1520-238-T).
  - d. **Install access panel R200** (para 2.2).

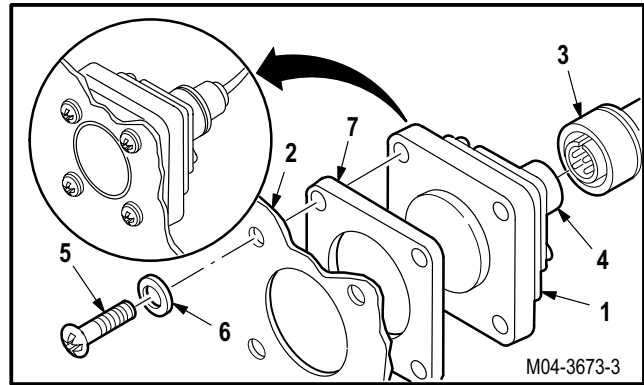

END OF TASK

## SECTION V. CANOPY JETTISON SYSTEM MAINTENANCE

### 12.76. CANOPY JETTISON SYSTEM INSPECTION

#### 12.76.1. Description

This task covers: Inspection.

#### 12.76.2. Initial Setup

**Tools:**

Aircraft mechanic's tool kit (item 376, App H)

**Equipment Conditions:**

<u>Ref</u>	<u>Condition</u>
1.57	Helicopter safed

**Personnel Required:**

67R     Attack Helicopter Repairer  
 67R3F   Attack Helicopter Repairer/Technical  
           Inspector

#### 12.76.3. Inspection

- a. **Check initiator handles for illegible placards.** Replace placard.
- b. **Check initiator handles for chafing, nicks, cuts, cracks, twists or loose attachment.** None allowed.
- c. **Check detonation cord for chafing, nicks, cuts, cracks, twists or loose attachment.** Replace detonation cord.
- d. **Check detonation cord for depressions.** If depression is greater than **20 PERCENT**. Replace detonation cord.
- e. **Check detonation cord retainer at screw holes for cracks.**
  - (1) If crack is **THROUGH ENTIRE RETAINER**. Replace severance assembly.
  - (2) If surface is cracked around screw hole, **25 PERCENT** of screw holes may be discrepant if scattered randomly. A maximum of **THREE CONSECUTIVE HOLES** are allowed.
- f. **Check all fittings for corrosion, dents, bulges, and loose attachment.** Replace fittings (para 1.49).
- g. **Check lockwire on fittings for breaks, looseness or improper installation.** None allowed.
- h. **Check general hardware for damage or looseness.** None allowed.

END OF TASK

**12.77. CANOPY SEVERANCE DEVICE REMOVAL/INSTALLATION**

12.77.1. Description

This task covers: Removal. Cleaning. Inspection. Installation.

12.77.2. Initial Setup

**Tools:**

Aircraft mechanic's tool kit (item 376, App H)  
 30 - 150 inch-pound 1/4-inch drive click type torque wrench (item 435, App H)

**References:**

TM 1-1270-476-20  
 TM 9-1230-476-20-1

**Materials/Parts:**

Packing (7)  
 Wire (item 224, App F)

**Equipment Conditions:**

<u>Ref</u>	<u>Condition</u>
1.57 TM 9-1230-476-20-1	Helicopter safed Pilot and/or CPG FIRE CONTROL panel removed (if required)
TM 1-1270-476-20	Optical relay tube removed (if required)

**Personnel Required:**

67R Attack Helicopter Repairer  
 67R3F Attack Helicopter Repairer/Technical Inspector



**Detonation cords are explosive. Do not move canopy initiator handles or remove safety pins. Detonation may cause injury to personnel. If injury occurs, seek medical aid.**



- Do not twist cord or damage booster cup at end of cord assembly.
- Do not damage canopy transparent panels or transparent barrier when performing maintenance in crew stations.
- Ensure that the detonating cord is not kinked. A kink in the cord may prevent the cord from firing. If a cord has been kinked it is no longer serviceable.

**NOTE**

- This task is typical for any detonation cord and its associated components, although differing in location and configuration.
- Cap or plug parts after disconnecting components. Remove plugs or caps before installing components.

GO TO NEXT PAGE

12.77. CANOPY SEVERANCE DEVICE REMOVAL/INSTALLATION - continued

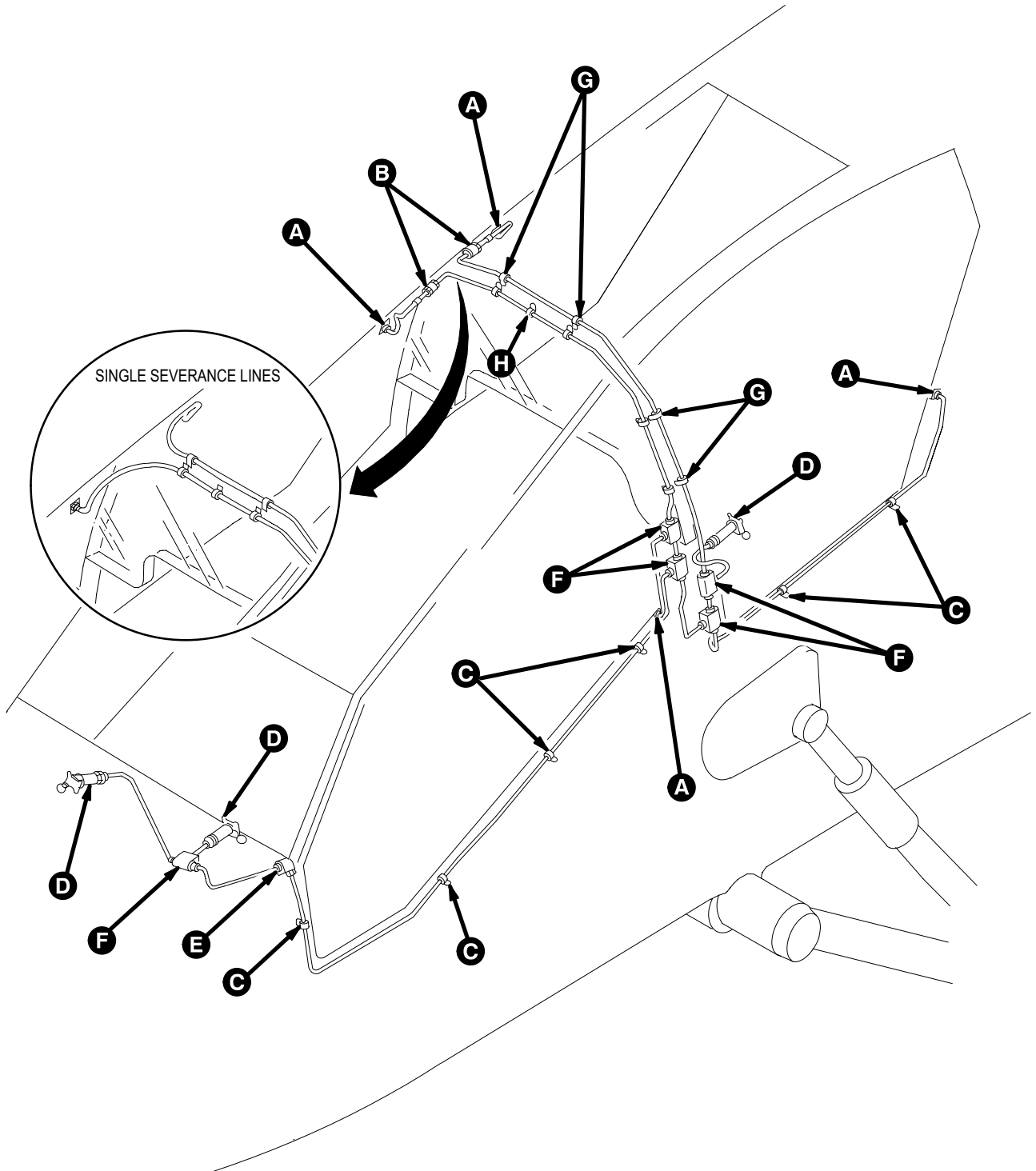

M04-3054-1

GO TO NEXT PAGE

**12.77. CANOPY SEVERANCE DEVICE REMOVAL/INSTALLATION - continued**

12.77.3. Removal

**a. Remove detonation cord (1) from initiation block (2).**

- (1) Remove lockwire.
- (2) Hold block (2). Remove nut (3).
- (3) Remove and discard packing (4).

**NOTE**

Step b will not be necessary for aircraft with one piece severance line.

**b. Remove cord (5) from union (6).**

- (1) Remove lockwire.
- (2) Hold union (6). Remove nut (7).
- (3) Remove and discard packing (8).

**c. Remove cord (9) from airframe (10).**

- (1) Remove screw (11) and washer (12) from airframe (10).
- (2) Remove clamp (13) from cord (9).

**d. Remove cord (14) from initiator handle (15).**

- (1) Remove lockwire.
- (2) Hold initiator (15). Remove nut (16).
- (3) Remove and discard packing (17).

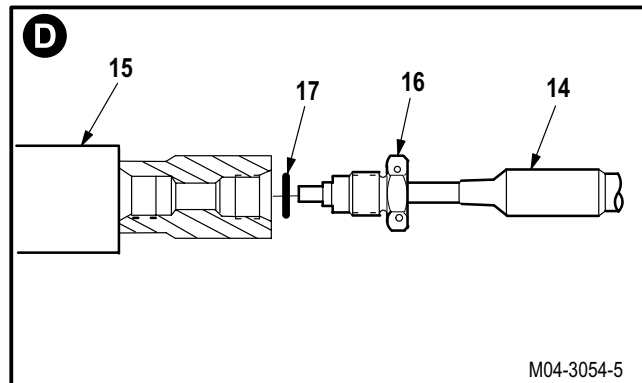
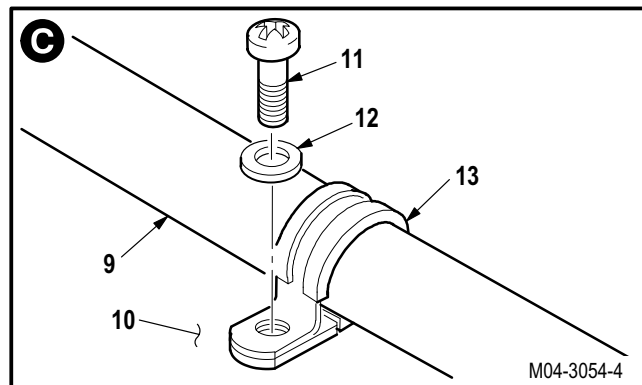
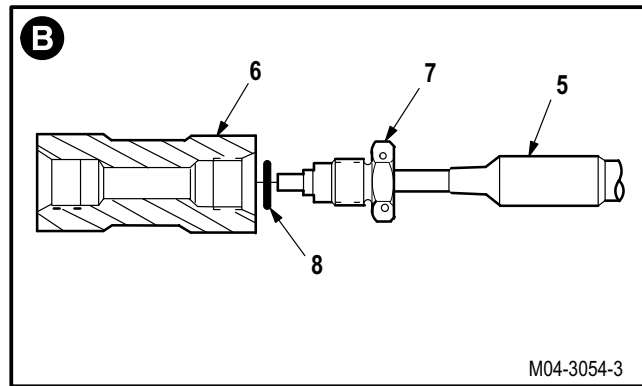
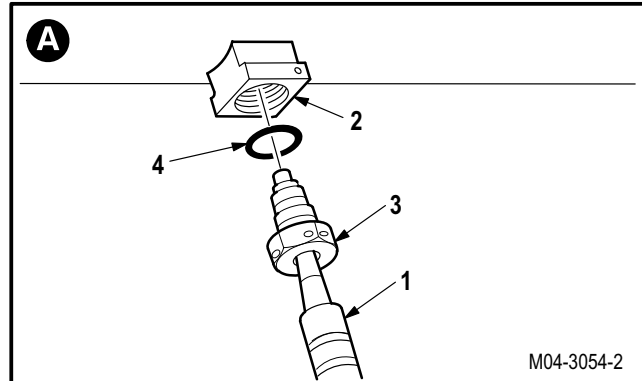

GO TO NEXT PAGE

**12.77. CANOPY SEVERANCE DEVICE REMOVAL/INSTALLATION - continued**

**e. Remove cord (18) from elbow (19).**

- (1) Remove lockwire.
- (2) Hold elbow (19). Remove nut (20).
- (3) Remove and discard packing (21).

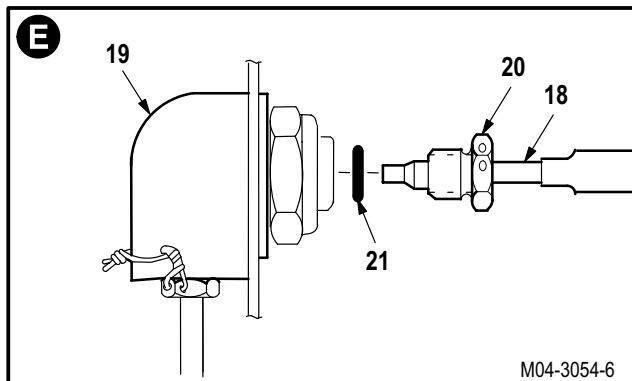

**f. Remove detonation tee (22) from airframe (10).**

- (1) Remove lockwire from cords (23), (24), and (25).
- (2) Hold tee (22). Remove nuts (26), (27), and (28).
- (3) Remove and discard packings (29).
- (4) Remove two bolts (30), washers (31), and tee (22) from airframe (10).

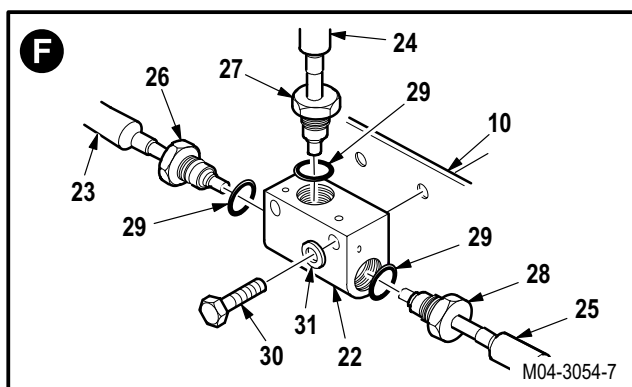

**g. Remove two cords (32) and (33) from roll-over structure (34).**

- (1) Hold screw (35). Remove nut (36) and washer (37).
- (2) Remove screw (35), two clamps (38), and cords (32) and (33) from structure (34).
- (3) Remove two clamps (38) from cords (32) and (33).

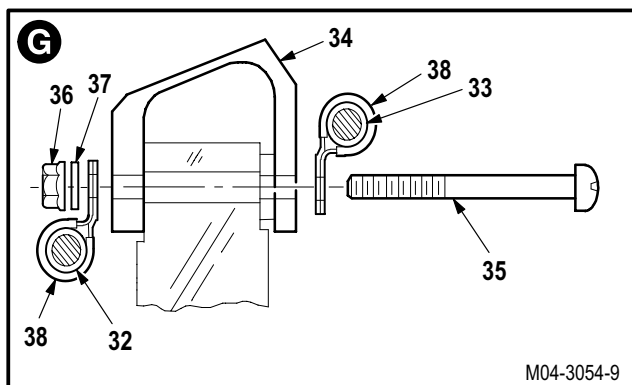

**h. Remove cord (32) from structure (34).**

- (1) Hold screw (39). Remove nut (40) and washer (41).
- (2) Remove screw (39), washer (41), clamp (42), and cord (32) from structure (34).
- (3) Remove clamp (42) from cord (32).

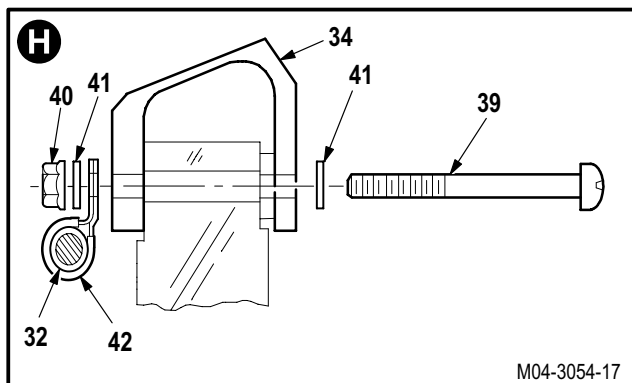

GO TO NEXT PAGE

**12.77. CANOPY SEVERANCE DEVICE REMOVAL/INSTALLATION - continued**

12.77.4. Cleaning

- a. **Wipe removed and attaching parts with a clean rag.**

12.77.5. Inspection

- a. **Check detonation cord, blocks, tees, couplings and elbows for cracks, dents, nicks, and stripped threads (para 12.76).**
- b. **Check removed and attaching parts for corrosion (para 1.49).**

12.77.6. Installation

a. **Install cord (32) on structure (34).**

- (1) Install clamp (42) on cord (32).
- (2) Install screw (39) through washer (41) and structure (34).
- (3) Hold screw (39). Install clamp (42), washer (41), and nut (40).

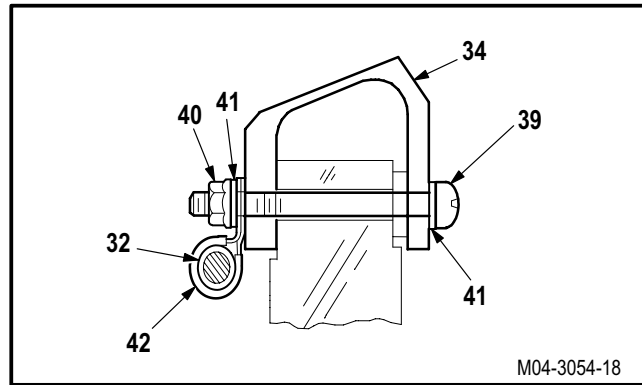

b. **Install two cords (32) and (33) on structure (34).**

- (1) Install two clamps (38) on cords (32) and (33).
- (2) Install screw (35) through clamp (38) and structure (34).
- (3) Hold screw (35). Install clamp (38), washer (37), and nut (36).

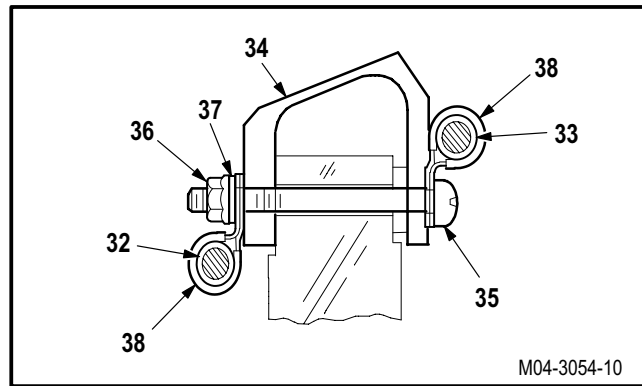

GO TO NEXT PAGE



**12.77. CANOPY SEVERANCE DEVICE REMOVAL/INSTALLATION - continued**

**c. Install tee (22) on airframe (10).**

- (1) Position tee (22) on airframe (10).
- (2) Install two bolts (30) through washers (31) and tee (22) on airframe (10).

**d. Install cords (23), (24), and (25) on tee (22). Torque nuts (26), (27), and (28) to 80 INCH-POUNDS.**

- (1) Install three new packings (29) on nuts (26), (27), and (28).
- (2) Install nuts (26), (27), and (28). Torque nuts (26), (27), and (28) to **80 INCH-POUNDS**. Use torque wrench.
- (3) Lockwire nuts (26), (27), and (28) to tee (22). Use wire (item 224, App F).

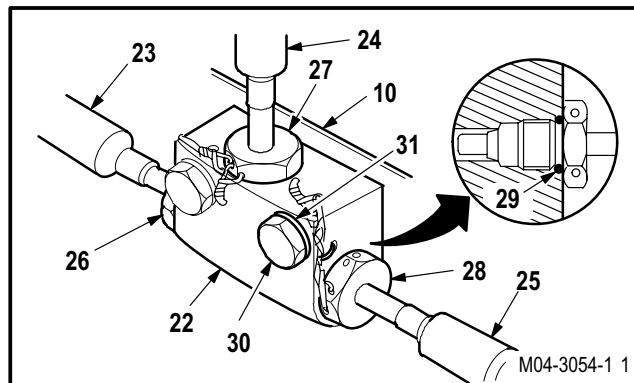

**e. Install cord (18) on elbow (19). Torque nut (20) to 80 INCH-POUNDS.**

- (1) Install new packing (21) on nut (20).
- (2) Install nut (20) on elbow (19).
- (3) Hold elbow (19). Torque nut (20) to **80 INCH-POUNDS**. Use torque wrench.
- (4) Lockwire nut (20) to elbow (19). Use wire (item 224, App F).

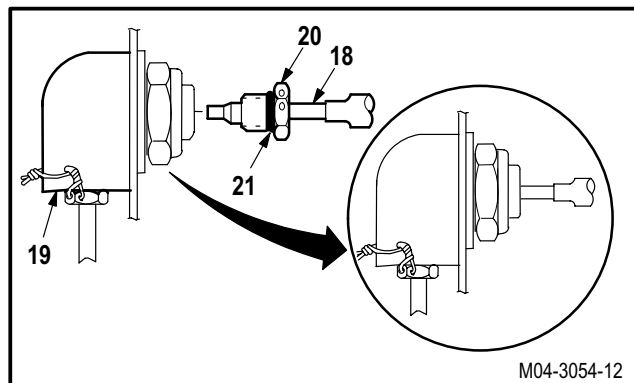

**f. Install cord (14) on initiator (15). Torque nut (16) to 80 INCH-POUNDS.**

- (1) Install new packing (17) on nut (16).
- (2) Install nut (16) on initiator (15).
- (3) Hold initiator (15). Torque nut (16) to **80 INCH-POUNDS**. Use torque wrench.
- (4) Lockwire nut (16) to initiator (15). Use wire (item 224, App F).

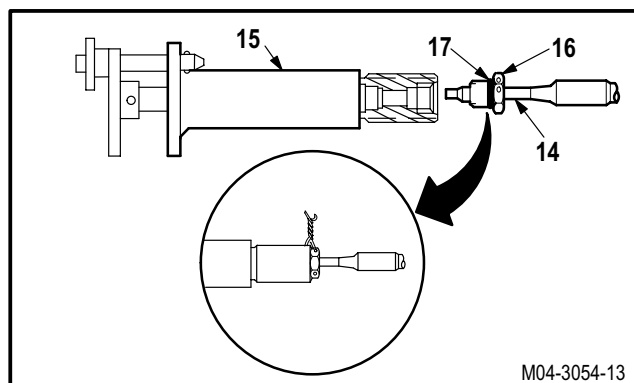

GO TO NEXT PAGE

**12.77. CANOPY SEVERANCE DEVICE REMOVAL/INSTALLATION - continued**

**g. Install cord (9) on airframe (10).**

- (1) Install clamp (13) on cord (9).
- (2) Install screw (11) through washer (12) and clamp (13) on airframe (10).

**NOTE**

Step h will not be necessary for aircraft equipped with one piece detonation cord.

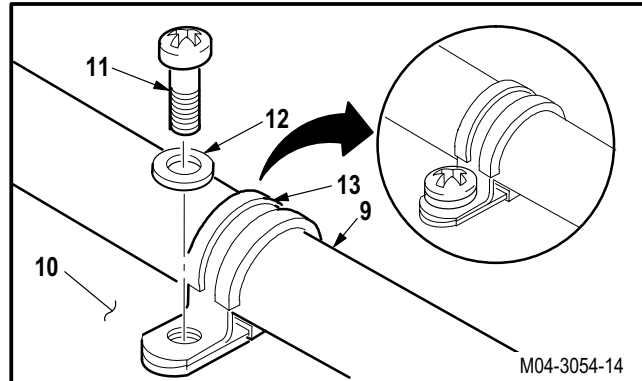

**h. Install cord (5) on union (6). Torque nut (7) to 80 INCH-POUNDS.**

- (1) Install new packing (8) on nut (7).
- (2) Install nut (7) on union (6).
- (3) Hold union (6). Torque nut (7) to **80 INCH-POUNDS**. Use torque wrench.
- (4) Lockwire nut (7) to union (6). Use wire (item 224, App F).

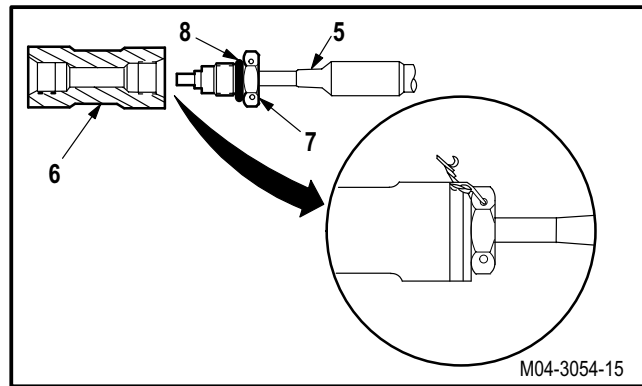

**i. Install cord (1) on block (2). Torque nut (3) to 80 INCH-POUNDS.**

- (1) Install new packing (4) on nut (3).
- (2) Install nut (3) on block (2).
- (3) Hold block (2). Torque nut (3) to **80 INCH-POUNDS**. Use torque wrench.
- (4) Lockwire nut (3) to block (2). Use wire (item 224, App F).

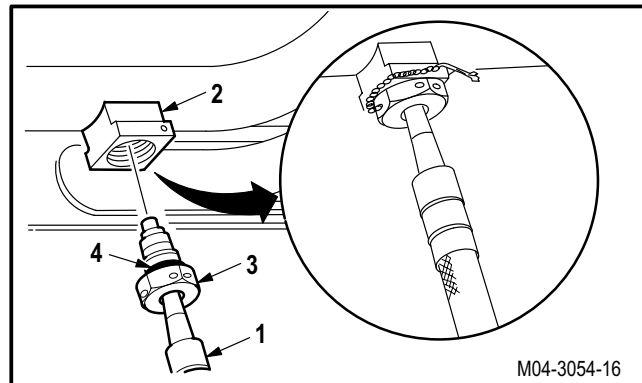

**j. Inspect (QA).**

**k. Install optical relay tube (if required) (TM 1-1270-476-20).**

**l. Install pilot and/or CPG FIRE CONTROL panel (if required) (TM 9-1230-476-20-1).**

END OF TASK

**12.78. CANOPY SEVERANCE INITIATOR HANDLE REMOVAL/INSTALLATION**

12.78.1. Description

This task covers: Removal. Cleaning. Inspection. Installation.

12.78.2. Initial Setup

**Tools:**

- Aircraft mechanic's tool kit (item 376, App H)
- Light duty laboratory apron (item 27, App H)
- 1 1/16 x 3/8-inch drive open end box socket wrench crowfoot attachment (item 71, App H)
- Chemical protective gloves (item 154, App H)
- Adjustable air filtering respirator (item 262, App H)
- 1 1/16 & 1 1/4-inch open end wrench (item 416, App H)
- 1 & 1 1/8-inch open end wrench (item 417, App H)
- 30 - 150 inch-pound 1/4-inch drive click type torque wrench (item 435, App H)

**Materials/Parts:**

- Packing with retainer
- Brush (item 34, App F)
- Sealing compound (item 179, App F)
- Wire (item 223, App F)

**Personnel Required:**

- 67R Attack Helicopter Repairer
- 67R3F Attack Helicopter Repairer/Technical Inspector

**References:**

- TM 1-1270-476-20
- TM 9-1230-476-20-1

**Equipment Conditions:**

<u>Ref</u>	<u>Condition</u>
1.57	Helicopter safed
12.77	Detonation cord removed from initiator handle
TM 9-1230-476-20-1	Pilot and/or CPG FIRE CONTROL panel removed (if required)
TM 1-1270-476-20	Optical relay tube removed (if required)



**WARNING**

**Detonation cords are explosive. Do not move canopy initiator handles or remove safety pins. Detonation may cause injury to personnel. If injury occurs, seek medical aid.**

**NOTE**

- This task is typical for replacement of pilot and/or CPG canopy initiator handles and maintenance station canopy initiator handle.
- Cap or plug parts after disconnecting components. Remove caps or plugs before installing components.

GO TO NEXT PAGE

12.78. CANOPY SEVERANCE INITIATOR HANDLE REMOVAL/INSTALLATION - continued

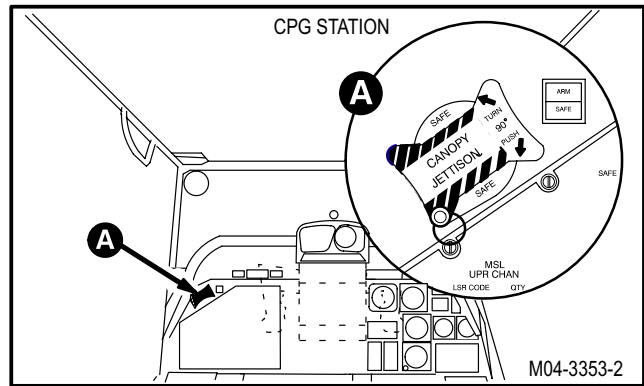
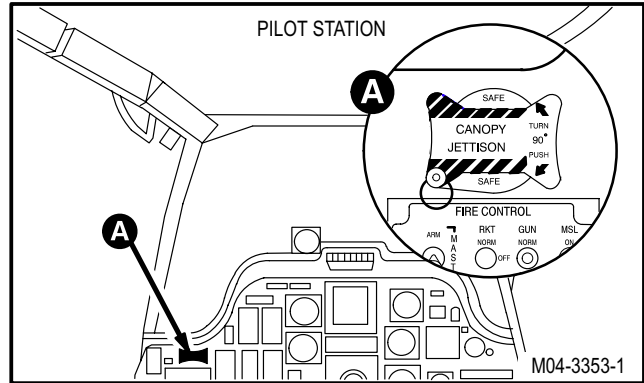

12.78.3. Removal

a. Enter pilot or CPG station (para 1.56). Observe all safety precautions.

b. Remove initiator handle (1) from pilot or CPG station.

- (1) Remove lockwire from nut (2).
- (2) Remove nut (3) and washer (4) from initiator handle (1). Use open end wrench.
- (3) Remove washer (5) and nut (2) from initiator handle (1). Use open end wrench.
- (4) Remove initiator handle (1) from bracket (6) and grommet (7).

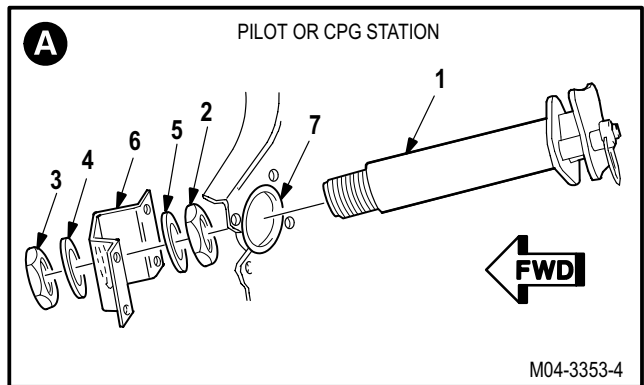

GO TO NEXT PAGE

---

**12.78. CANOPY SEVERANCE INITIATOR HANDLE REMOVAL/INSTALLATION - continued**

---

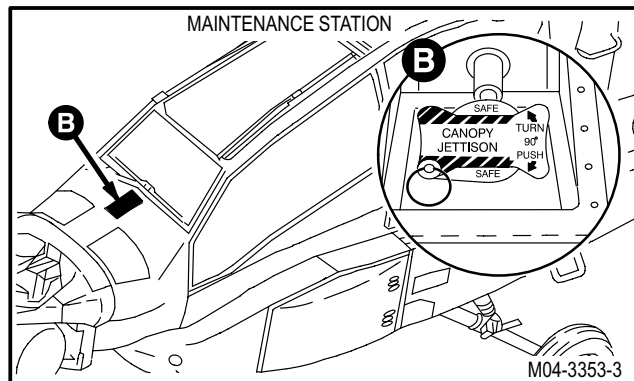
**c. Remove initiator handle (8) from maintenance station.**

- (1) Remove two screws (9) from bracket (10).
- (2) Remove clamp (11).
- (3) Remove sealing compound from nut (12), washer (13), and airframe (14) (para 1.47).
- (4) Remove lockwire from nut (12).
- (5) Remove nut (15) and washer (16) from initiator (8). Use open end wrench.
- (6) Remove and discard packing with retainer (17).
- (7) Remove initiator handle (8) from bracket (10) and airframe (14).
- (8) Remove washer (13) and nut (12) from initiator handle (8). Use open end wrench.

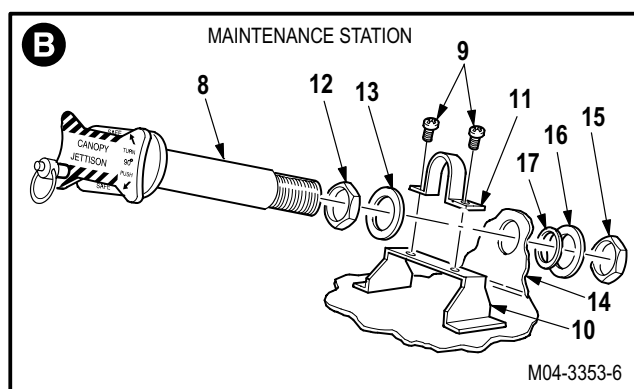
**12.78.4. Cleaning**

- a. **Wipe removed and attaching parts with a clean rag.**

**12.78.5. Inspection**

- a. **In pilot and CPG stations, check grommet for deterioration** (para 12.76).
- b. **Check initiator handle for damage** (para 12.76).

GO TO NEXT PAGE

12.78. CANOPY SEVERANCE INITIATOR HANDLE REMOVAL/INSTALLATION - continued

- c. Check removed and attaching parts for corrosion (para 1.49).



**WARNING**

Detonation cords are explosive. Do not move canopy initiator handles or remove safety pins. Detonation may cause injury to personnel. If injury occurs, seek medical aid.

12.78.6. Installation

- a. Install initiator handle (1) in pilot or CPG station. Torque nut (3) to 125 INCH-POUNDS.

- (1) Install initiator handle (1) through grommet (7).
- (2) Install nut (2) and washer (5) on initiator handle (1). Use open end wrench.
- (3) Install initiator handle (1) through bracket (6) until washer (5) contacts bracket (6).
- (4) Install washer (4) and nut (3) on initiator handle (1).
- (5) Position initiator handle (1) so that interference will not exist with pilot or CPG **FIRE CONTROL** panel.
- (6) Torque nut (3) to 125 INCH-POUNDS. Use crowfoot and torque wrench.
- (7) Lockwire nut (2) to bracket (6). Use wire (item 223, App F).

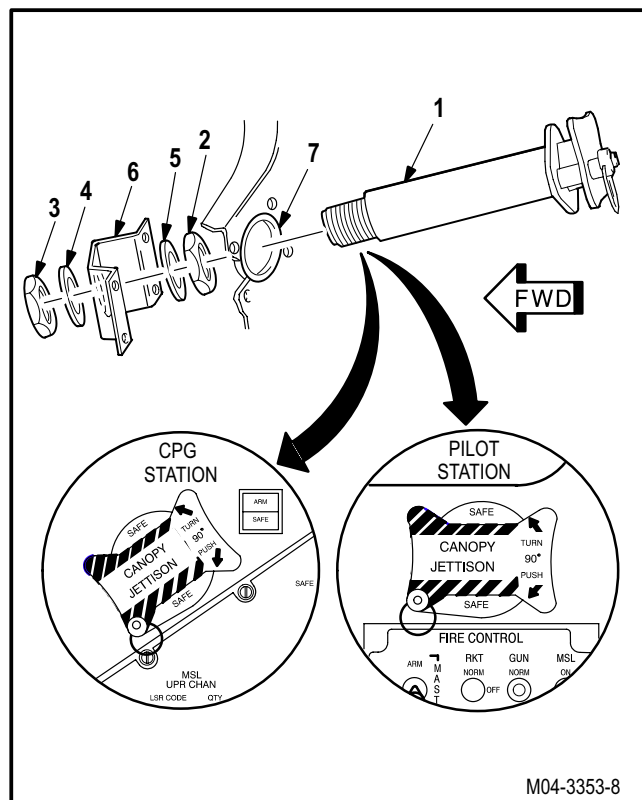

GO TO NEXT PAGE

**12.78. CANOPY SEVERANCE INITIATOR HANDLE REMOVAL/INSTALLATION - continued****b. Install initiator handle (8) in maintenance station. Torque nut (15) to 125 INCH-POUNDS.**

- (1) Install nut (12) and washer (13) on initiator handle (8). Use open end wrench.
- (2) Install initiator handle (8) through airframe (14).
- (3) Install new packing with retainer (17) on initiator handle (8).
- (4) Install washer (16) and nut (15) on initiator handle (8).
- (5) Position initiator handle (8) so that interference will not exist with access cover.
- (6) Torque nut (15) to **125 INCH-POUNDS**. Use crowfoot and torque wrench.
- (7) Lockwire nut (12) to bracket (10). Use wire (item 223, App F).
- (8) Position clamp (11) on initiator handle (8).
- (9) Install two screws (9) on bracket (10).

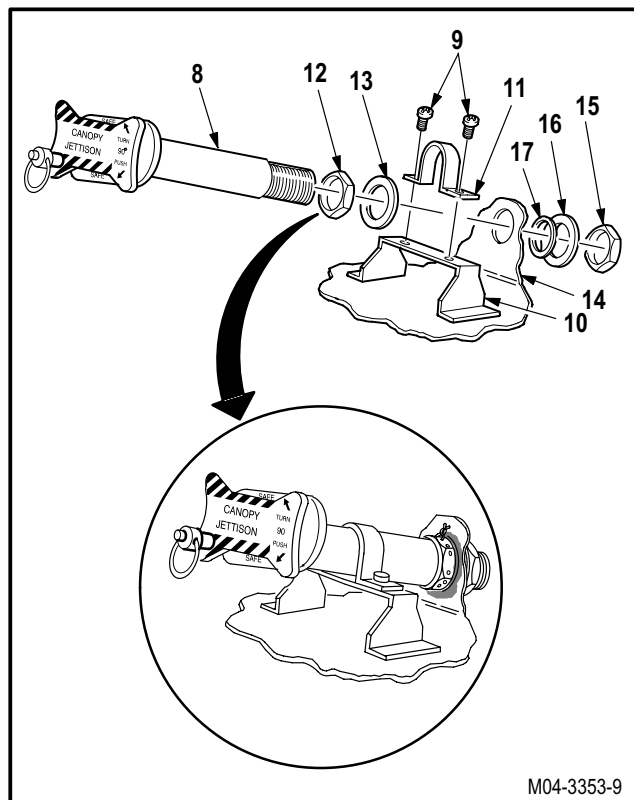

M04-3353-9



- c. **Apply sealing compound around edges of nut (12) and washer (13).** Use sealing compound (item 179, App F) and brush (item 34, App F).
- d. **Inspect (QA).**
- e. **Install detonation cord to initiator handle** (para 12.77).
- f. **Install optical relay tube (if removed)** (TM 1-1270-476-20).
- g. **Install pilot and/or CPG FIRE CONTROL panel (if removed)** (TM 9-1230-476-20-1).

END OF TASK





## CHAPTER 13 ENVIRONMENTAL CONTROL SYSTEM

### CHAPTER OVERVIEW

Chapter 13 contains the maintenance instructions for the environmental control and defog systems. Environmental control and defog systems description, operation, and troubleshooting information is contained in TM 1-1520-238-T.

### CHAPTER INDEX

<u>Para Title</u>	<u>Para No.</u>
<b>SECTION I. ENVIRONMENTAL CONTROL SYSTEM MAINTENANCE</b>	
Environmental Control System (ECS) Inspection .....	13.1
ECS Air Duct Identification .....	13.2
Environmental Control Unit (ENCU) Removal/Installation .....	13.3
ENCU Air Cooling Duct Assembly Removal/Installation .....	13.4
ENCU Air Outlet Duct Replacement .....	13.5
ENCU Temperature Control Shutoff Valve Removal/Installation .....	13.6
ENCU Electrical Control Valve Removal/Installation .....	13.7
ENCU Temperature Control Shutoff Valve/Electrical Control Valve Cleaning .....	13.8
ENCU Cooling Turbine Assembly Removal/Installation .....	13.9
ENCU Water Extractor Assembly Replacement .....	13.10
ENCU Temperature Control Sensor Removal/Installation .....	13.11
ENCU Filter Removal/Installation .....	13.12
ENCU Overboard Exhaust Duct Removal/Installation .....	13.13
ENCU Support Removal/Installation .....	13.14

CHAPTER INDEX - continued

<u>Para Title</u>	<u>Para No.</u>
ECS Shutoff Valve Removal/Installation .....	13.15
ECS Shutoff Valve Filter Element Removal/Installation .....	Deleted
Air Duct No. 1 Removal/Installation .....	13.17
Air Duct No. 2 Removal/Installation .....	13.18
Air Duct No. 3 Removal/Installation .....	13.19
Air Duct No. 4 Removal/Installation .....	13.20
Air Duct No. 5 Removal/Installation .....	13.21
Air Duct No. 6 Removal/Installation .....	13.22
Air Duct No. 7 Removal/Installation .....	13.23
Air Duct No. 8 Removal/Installation .....	13.24
Air Duct No. 9 Removal/Installation .....	13.25
Air Duct No. 10 Removal/Installation .....	13.26
Air Duct No. 11 Removal/Installation .....	13.27
ECS Crew Station Ducts Removal/Installation .....	13.28
ECS Duct Seal Replacement .....	13.29
Forward Avionics Bay Vaneaxial Fan Removal/Installation .....	13.30
Forward Avionics Bay Vaneaxial Fan Air Duct Removal/Installation .....	13.31
Forward Avionics Bay Air Cooling Duct Assembly Removal/Installation .....	13.32
Aft Vaneaxial Fan Removal/Installation .....	13.33
ECS Panel Removal/Installation .....	13.34
ECS Panel Light Indicating Panel Removal/Installation .....	13.35
ECS Panel Resistor Assembly Removal/Installation (AVIM) .....	13.36
ECS Panel Variable Resistor Replacement (AVIM) .....	13.37
ECS Panel Toggle Switch Replacement (AVIM) .....	13.38

## CHAPTER INDEX - continued

<u>Para Title</u>	<u>Para No.</u>
ECS Panel Receptacle Replacement (AVIM) .....	13.39
ECS Support Panel Removal/Installation (AVIM) .....	13.40
ECS Forward Avionics Bay Thermostatic Switch Replacement .....	13.41
ECS Aft Avionics Bay Thermostatic Switch Replacement .....	13.42
 <b>SECTION II. DEFOG SYSTEM MAINTENANCE</b>	
Defog System Inspection .....	13.43
Defog Shutoff Valve Removal/Installation .....	13.44
Defog System Air Mixer and Hose Removal/Installation .....	13.45

## SECTION I. ENVIRONMENTAL CONTROL SYSTEM MAINTENANCE

### 13.1. ENVIRONMENTAL CONTROL SYSTEM (ECS) INSPECTION

#### 13.1.1. Description

This task covers: Inspection.

#### 13.1.2. Initial Setup

**Tools:**

Aircraft mechanic's tool kit (item 376, App H)

**References:**

TM 1-1500-204-23  
 TM 55-1500-323-24

**Materials/Parts:**

Tape (item 200, App F)

**Personnel Required:**

67R     Attack Helicopter Repairer  
 67R3F   Attack Helicopter Repairer/Technical  
           Inspector

**Equipment Conditions:**

<u>Ref</u>	<u>Condition</u>
1.57	Helicopter safed

#### 13.1.3. Inspection

- a. **Check tubes for chafing, cracks, or nicks.** Replace damaged tubing.
- b. **Check ducts for chafing, cracks, dents, nicks, or scratches.** Replace damaged ducting. If duct is not damaged and is chafing on components, install tape to protect duct (para 13.28).
- c. **Check duct cuffs and insulation for chafing, cracks, or tears.** Replace damaged cuffs or insulation.
  - (1) Chafing between cuffs and insulation and other components is allowed if insulation compression does not exceed **0.25 INCHES**.
  - (2) Repair tears on insulation. Use tape (item 200, App F).
  - (3) Repair tears on cuffs less than **1 INCH**. Use tape (item 200, App F).
- d. **Check ECS ducts for air leaks.**
- e. **Check rubber seals for chafing, cuts, or fraying.** Replace damaged seals (para 13.29).
- f. **Check clamps for security, wear, and cracks which can chafe and damage ducts.** Replace damaged clamps.
- g. **Check nutplates for loose rivets and stripped or damaged threads** (TM 1-1500-204-23).

GO TO NEXT PAGE

---

**13.1. ENVIRONMENTAL CONTROL SYSTEM (ECS) INSPECTION - continued**

---

- h. **Check connectors for loose or bent pins, thread damage, and for frayed, cut, or loose wires** (TM 55-1500-323-24).
- i. **Check connector operation for smooth positive locking action** (TM 55-1500-323-24).
- j. **Check general mounting hardware for cracks, gouges, nicks, scratches, chafing, damage, rounded flats, and stripped or damaged threads.** Replace damaged hardware.
- k. **Check environmental control unit (ENCU) for fluid leaks, cracks, and loose or missing hardware.** None allowed.
- l. **Check ENCU for chafing on fire extinguisher tubing.** Minimum clearance between ENCU and tubing **0.25 INCH** (para 12.33).
- m. **Check pilot ECS control panel and CPG AUX panel for loose knobs and switches.** None allowed.
- n. **Inspect ENCU filter (if installed) for damage and cleanliness.** Replace or clean filter as necessary (para 13.12).
- o. **Check ECS shutoff valve body for dents or cracks.** None allowed.
- p. **Check ECS shutoff valve for scored, cracked, or distorted flanges.** None allowed.
- q. **Check identification plate for legibility, deformation, and security of attachment.**
- r. **Check cooling turbine for evidence of oil leakage, impeller contact in fan outlet, and metal debris in and around fan outlet.** None allowed.
- s. **Check cooling turbine for cracked or broken ports and flanges.** None allowed.

END OF TASK

13.2. ECS AIR DUCT IDENTIFICATION

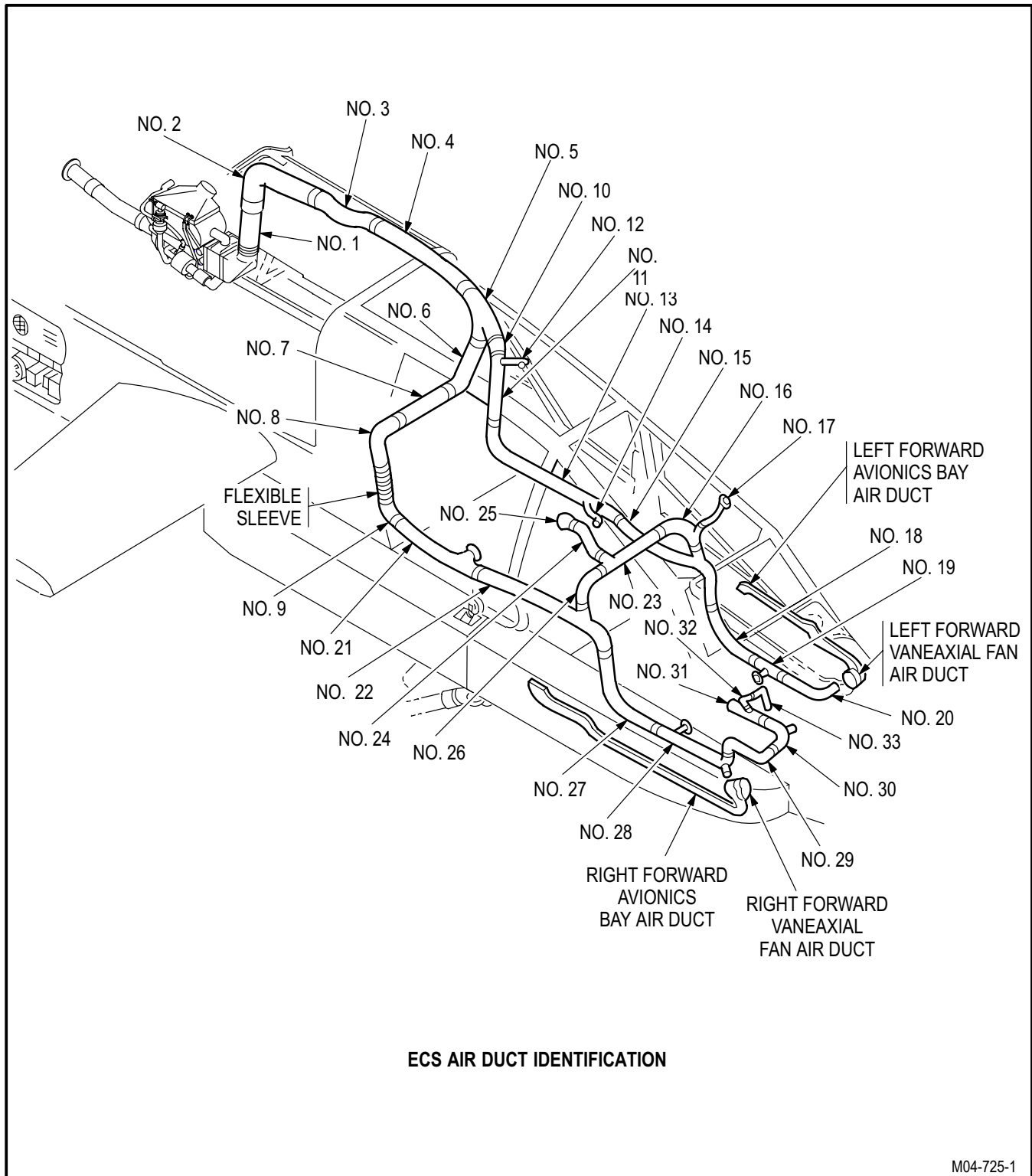

### 13.3. ENVIRONMENTAL CONTROL UNIT (ENCU) REMOVAL/INSTALLATION

#### 13.3.1. Description

This task covers: Removal. Cleaning. Inspection. Installation.

#### 13.3.2. Initial Setup

##### Tools:

- Aircraft mechanic's tool kit (item 376, App H)
- Light duty laboratory apron (item 27, App H)
- Chemical protective gloves (item 154, App H)
- Adjustable air filtering respirator (item 262, App H)
- 30 - 150 inch-pound 1/4-inch drive click type torque wrench (item 435, App H)

##### Materials/Parts:

- Packing
- Petrolatum (item 138, App F)
- Sealing compound (item 174, App F)
- Strap (item 192, App F)
- Tape (item 200, App F)

##### Personnel Required:

- 67R Attack Helicopter Repairer
- 67R3F Attack Helicopter Repairer/Technical Inspector

##### References:

TM 1-1520-238-T

##### Equipment Conditions:

Ref	Condition
1.57	Helicopter safed
2.2	Access doors T250L, T250R, T290L, T290R, and L325 opened

**CAUTION**

To prevent damage to fire bottle squibs, caution must be used during ENCU removal/installation.

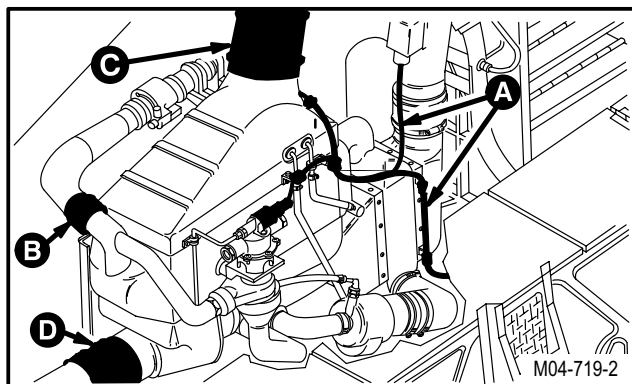

GO TO NEXT PAGE

**13.3. ENVIRONMENTAL CONTROL UNIT (ENCU) REMOVAL/INSTALLATION - continued**

**13.3.3. Removal**

**a. Remove wire harness W119 (1) from ENCU (2).**

- (1) Detach connector P287 (3) from temperature control valve receptacle (L39)J1 (4).
- (2) Detach connector P285 (5) from temperature control sensor receptacle (A43)J1 (6).
- (3) Remove four screws (7), washers (8), and nuts (9) from clamps (10) and brackets (11).
- (4) Remove tiedown strap (12) from harness (1).

**NOTE**

If ENCU is to be replaced, go to step b. If ENCU is to be reinstalled, go to step c.

**b. Remove four brackets (11) from ENCU (2).**

- (1) Remove four screws (13) and washers (14) from ENCU (2).
- (2) Remove and retain four brackets (11).
- (3) Install four screws (13) and washers (14) on ENCU (2).

**c. Remove coupling (15) from duct (16) and ENCU (2).**

- (1) Remove nut (17) and coupling (15).
- (2) Remove and discard packing (18).

**d. Remove sleeve (19) from duct (20) and ENCU (2).**

- (1) Loosen two clamps (21).
- (2) Remove sleeve (19) and clamps (21).

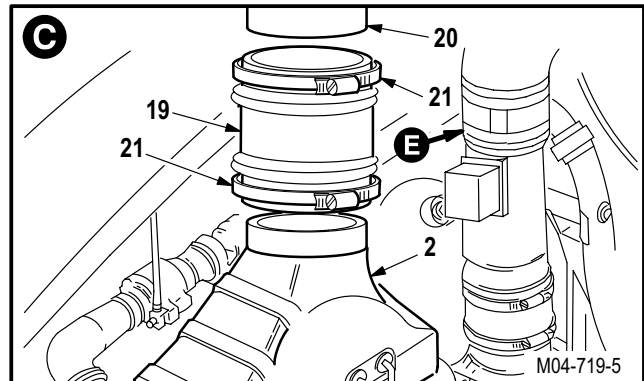
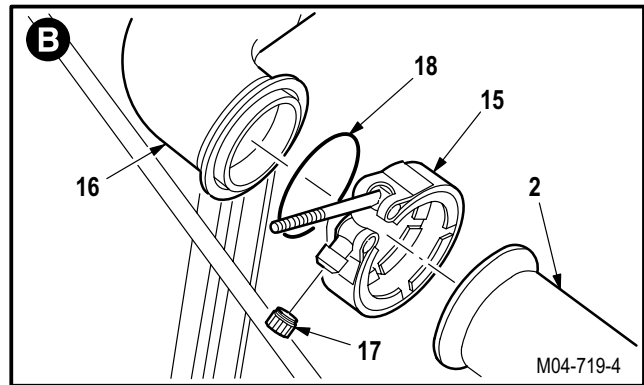
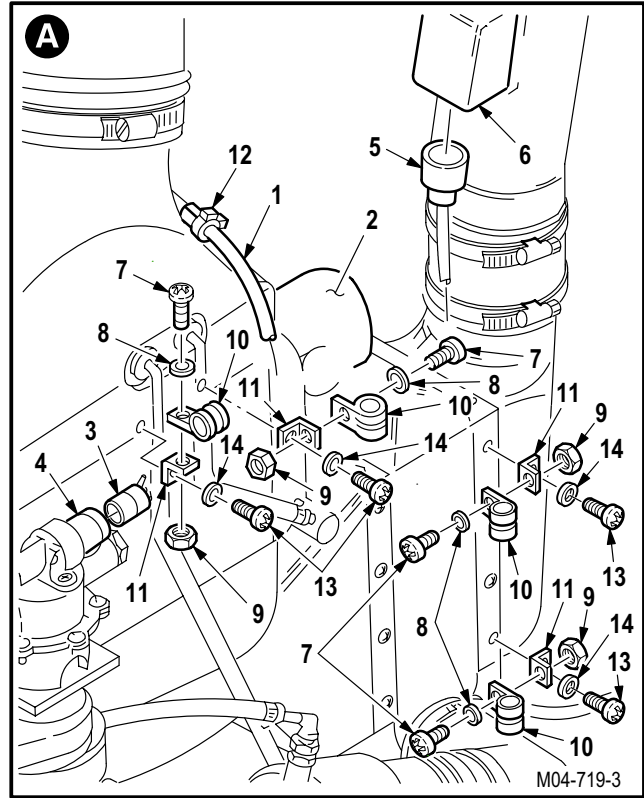

GO TO NEXT PAGE



### 13.3. ENVIRONMENTAL CONTROL UNIT (ENCU) REMOVAL/INSTALLATION - continued

e. **Remove sleeve (22) from duct (23) and ENCU (2).**

- (1) Loosen two clamps (24).
- (2) Remove sleeve (22) and clamps (24).

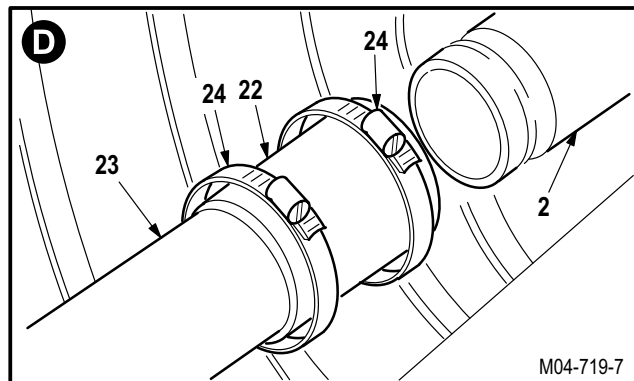

f. **Remove cuff (25) from duct (26) and ENCU (2).**

- (1) Remove tape (27) and separate cuff (25) velcro strips.
- (2) Remove cuff (25).

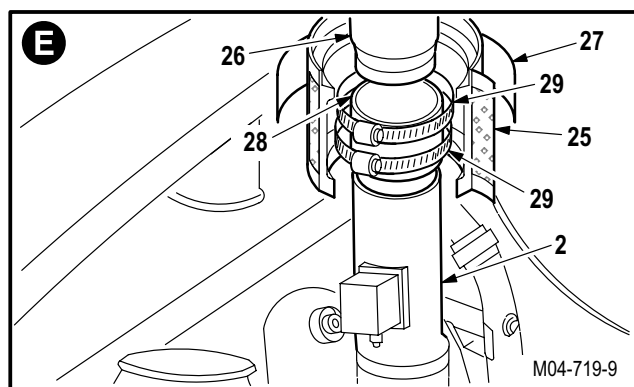

g. **Remove sleeve (28) from duct (26) and ENCU (2).**

- (1) Loosen two clamps (29).
- (2) Remove sleeve (28) and clamps (29).

h. **Remove ENCU (2) from support (30).**

- (1) Remove sealant from two forward bolts (31) and washers (32) (para 1.47).
- (2) Remove four bolts (31) and washers (32).
- (3) Remove ENCU (2).

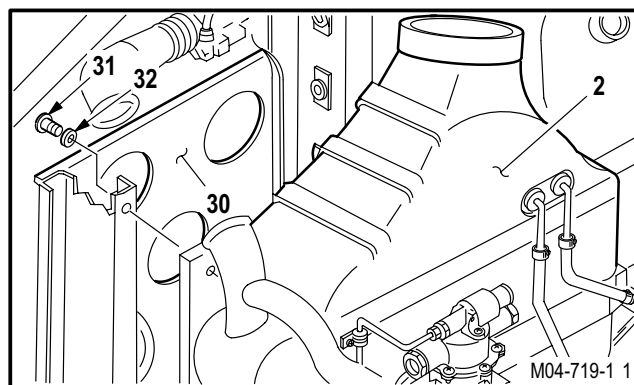

#### 13.3.4. Cleaning

a. **Wipe removed and attaching parts with a clean rag.**

#### 13.3.5. Inspection

- a. **Check support and aft deck mounting area for hole elongation, cracks, and stripped or damaged threads** (para 13.1).
- b. **Check ENCU inlet cooling air surfaces for dirt, debris, and oil film** (para 1.48).
- c. **Check sleeves and cuffs for rips or tears** (para 13.1).
- d. **Check removed and attaching parts for corrosion** (para 1.49).

GO TO NEXT PAGE

**13.3. ENVIRONMENTAL CONTROL UNIT (ENCU) REMOVAL/INSTALLATION - continued**

13.3.6. Installation



a. **Install ENCU (2) on support (30).** Torque four bolts (31) to **70 INCH-POUNDS**.

- (1) Position ENCU (2) on support (30).
- (2) Install four bolts (31) and washers (32). Torque bolts to **70 INCH-POUNDS**. Use torque wrench.
- (3) Apply sealing compound to forward two bolts (31) and washers (32). Use sealing compound (item 174, App F).

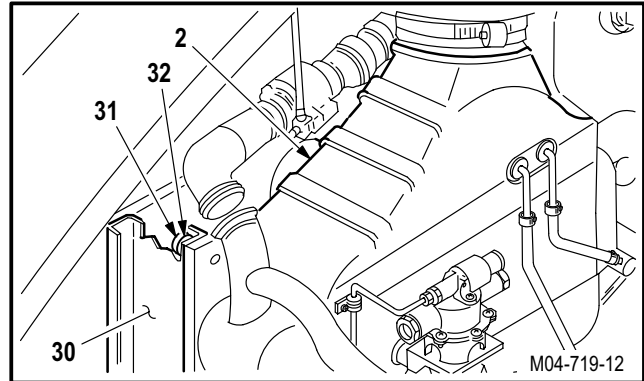

b. **Install sleeve (28) on duct (26) and ENCU (2).**

- (1) Install sleeve (28) and two clamps (29) on ENCU (2).
- (2) Center sleeve (28) over duct (26) and ENCU (2).
- (3) Tighten clamps (29).

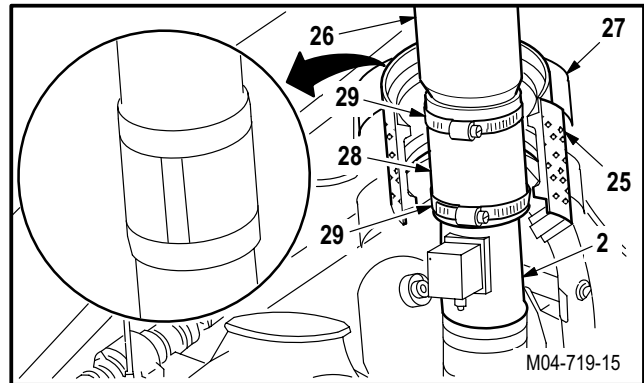

c. **Install cuff (25) on duct (26) and ENCU (2).**

- (1) Position cuff (25) over duct (26) and ENCU (2).
- (2) Secure cuff (25) velcro strips together.
- (3) Install tape (27) on cuff (25). Use tape (item 200, App F).

GO TO NEXT PAGE

**13.3. ENVIRONMENTAL CONTROL UNIT (ENCU) REMOVAL/INSTALLATION - continued**

**d. Install sleeve (22) on duct (23) and ENCU (2).**

- (1) Install sleeve (22) and two clamps (24) on ENCU (2).
- (2) Center sleeve (22) over duct (23) and ENCU (2).
- (3) Tighten clamps (24).

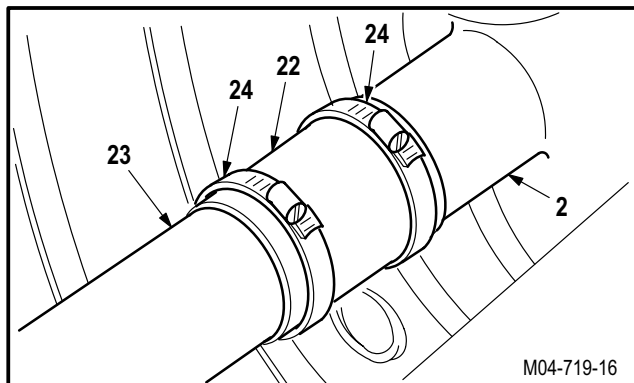

**e. Install coupling (15) on duct (16) and ENCU (2).**

- (1) Lubricate new packing (18). Use petrolatum (item 138, App F).
- (2) Install packing (18) on duct (16).
- (3) Install coupling (15) and nut (17).

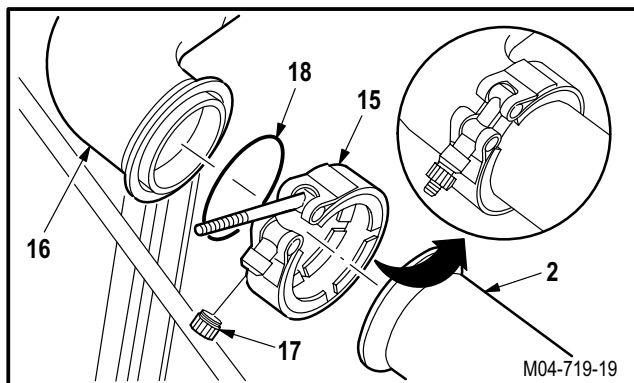

**f. Install sleeve (19) on duct (20) and ENCU (2).**

- (1) Center sleeve (19) over duct (20) and ENCU (2).
- (2) Install two clamps (21) on sleeve (19).

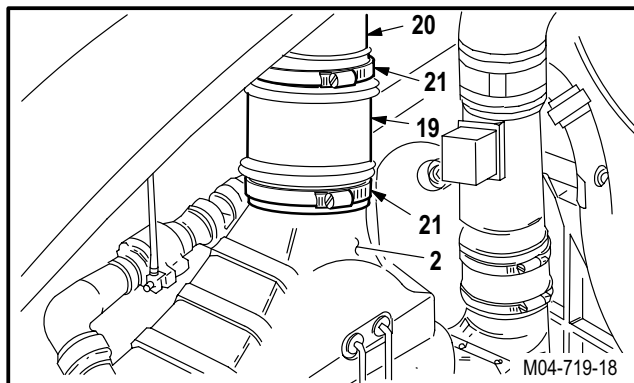

GO TO NEXT PAGE

**13.3. ENVIRONMENTAL CONTROL UNIT (ENCU) REMOVAL/INSTALLATION - continued**

**NOTE**

If ENCU was replaced, go to step g. If ENCU was reinstalled, go to step h.

**g. Install four brackets (11) on ENCU (2).**

- (1) Remove four screws (13) and washers (14) from ENCU (2).
- (2) Install four screws (13) through washers (14) and brackets (11) on ENCU (2).

**h. Install wire harness W119 (1) on ENCU (2).**

- (1) Install four screws (7) through washers (8), clamps (10), bracket (11), and nuts (9).
- (2) Install tiedown strap (12) on harness (1). Use strap (item 192, App F).
- (3) Attach connector P285 (5) to temperature control sensor receptacle (A43)J1 (6).
- (4) Attach connector P287 (3) to temperature control valve receptacle (L39)J1 (4).

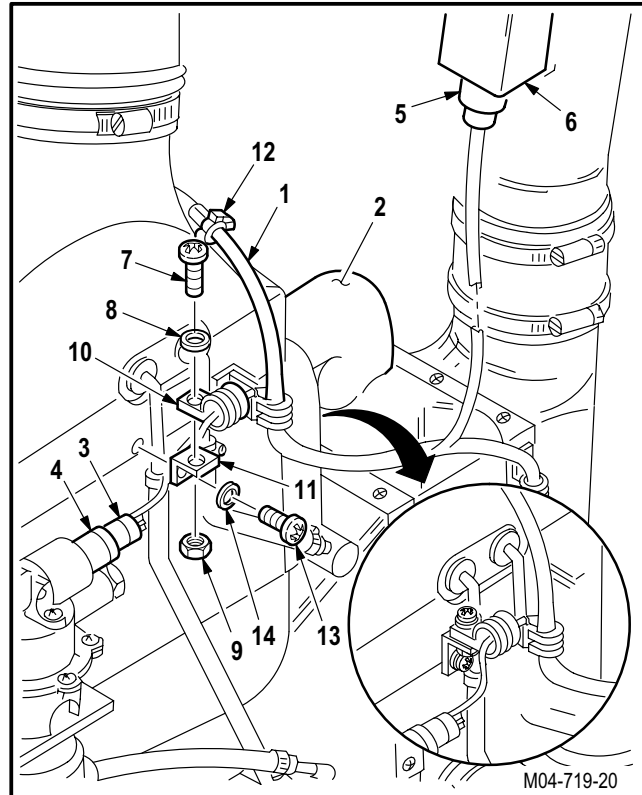

**CAUTION**

Ensure there is no chafing between the ENCU and the fire extinguisher tubing (para 13.1). Failure to do so could cause a malfunction of the ECS or fire extinguishing systems.

**i. Inspect (QA).**

**j. Perform ECS maintenance operational check (TM 1-1520-238-T).**

**k. Secure access doors T250L, T250R, T290L, T290R, and L325 (para 2.2).**

END OF TASK

**13.4. ENCUC AIR COOLING DUCT ASSEMBLY REMOVAL/INSTALLATION**

13.4.1. Description

This task covers: Removal. Cleaning. Inspection. Installation.

13.4.2. Initial Setup

**Tools:**

- Aircraft mechanic's tool kit (item 376, App H)
- Light duty laboratory apron (item 27, App H)
- Chemical protective gloves (item 154, App H)
- Adjustable air filtering respirator (item 262, App H)

**Materials/Parts:**

- Adhesive (item 16, App F)

**Personnel Required:**

- 67R Attack Helicopter Repairer
- 67R3F Attack Helicopter Repairer/Technical Inspector

**Equipment Conditions:**

<u>Ref</u>	<u>Condition</u>
1.57	Helicopter safed
13.9	ENCUC cooling turbine assembly removed

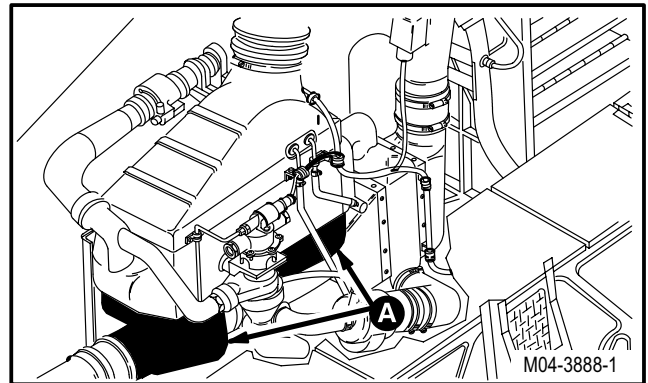

GO TO NEXT PAGE

---

**13.4. ENCU AIR COOLING DUCT ASSEMBLY REMOVAL/INSTALLATION - continued**

---

13.4.3. Removal

a. **Remove ENCU air cooling duct assembly (1) from ENCU (2).**

- (1) Remove nine screws (3) and washers (4) from duct (1).
- (2) Remove three screws (3) and washers (4) from clamps (5) and duct (1).
- (3) Remove duct (1).

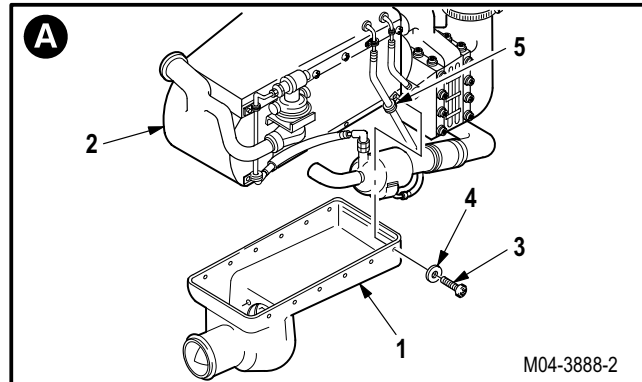

13.4.4. Cleaning

- a. **Clean adhesive from ENCU and duct (para 1.47).**
- b. **Wipe removed and attaching parts with a clean rag.**

13.4.5. Inspection

- a. **Check duct for chafing, cracks, or dents (para 13.1).**
- b. **Check duct nutplates for loose rivets and stripped or damaged threads (para 13.1).**
- c. **Check removed and attaching parts for corrosion (para 1.49).**

GO TO NEXT PAGE

---

**13.4. ENCU AIR COOLING DUCT ASSEMBLY REMOVAL/INSTALLATION - continued**



---

13.4.6. Installation**a. Install duct (1) on ENCU (2).**

- (1) Aline duct (1) on ENCU (2).
- (2) Install nine screws (3) and washers (4) on duct (1).
- (3) Install three screws (3) and washers (4) through clamps (5) and duct (1).

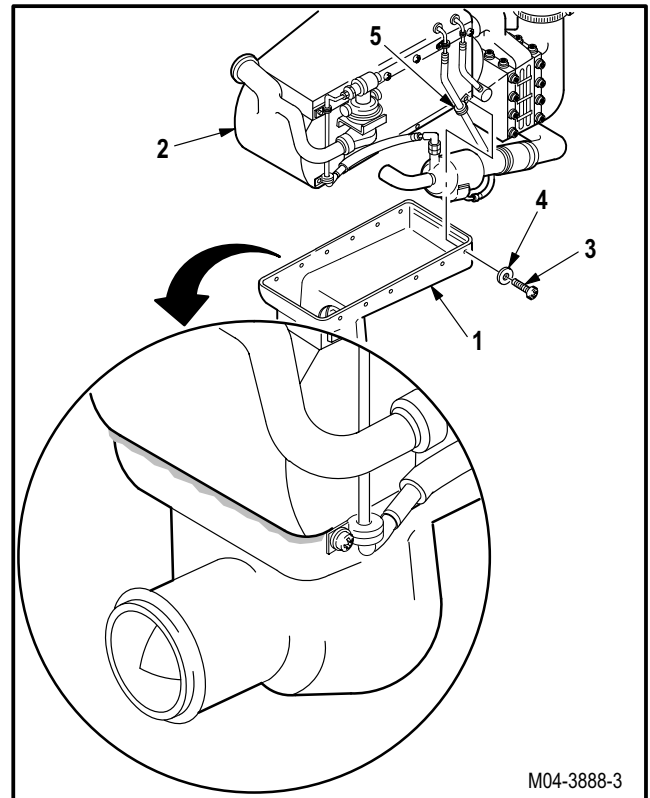

- b. Apply adhesive at mating areas of duct (1) and ENCU (2) and apply adhesive to completely fill gap at each end of duct (1). Use adhesive (item 16, App F).**
- c. Allow adhesive to dry 24 HOURS at 65 °F minimum.**
- d. Inspect (QA).**
- e. Install ENCU cooling turbine assembly (para 13.9).**



END OF TASK

---

## 13.5. ENCU AIR OUTLET DUCT REPLACEMENT

---

### 13.5.1. Description

This task covers: Removal. Cleaning. Inspection. Installation.

---

### 13.5.2. Initial Setup

#### **Tools:**

Aircraft mechanic's tool kit (item 376, App H)  
Light duty laboratory apron (item 27, App H)  
Chemical protective gloves (item 154, App H)  
Adjustable air filtering respirator (item 262, App H)

#### **Materials/Parts:**

Adhesive (item 16, App F)

#### **Personnel Required:**

67R Attack Helicopter Repairer  
67R3F Attack Helicopter Repairer/Technical  
Inspector

#### **Equipment Conditions:**

<u>Ref</u>	<u>Condition</u>
1.57	Helicopter safed
13.3	ENCU removed

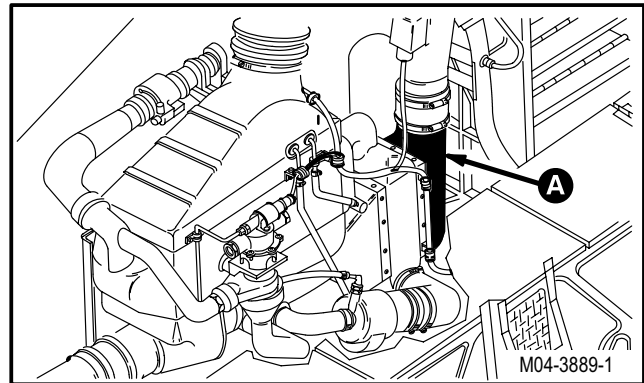

GO TO NEXT PAGE



---

**13.5. ENCUC AIR OUTLET DUCT REPLACEMENT - continued**

---

**13.5.3. Removal****a. Remove sleeve (1) from air outlet duct (2).**

(1) Loosen two clamps (3) from sleeve (1).

(2) Slide sleeve (1) on duct (4).

(3) Remove clamps (3).

**b. Remove duct (2) from ENCUC (5).**

(1) Remove 16 screws (6) and washers (7).

(2) Remove and discard duct (2).

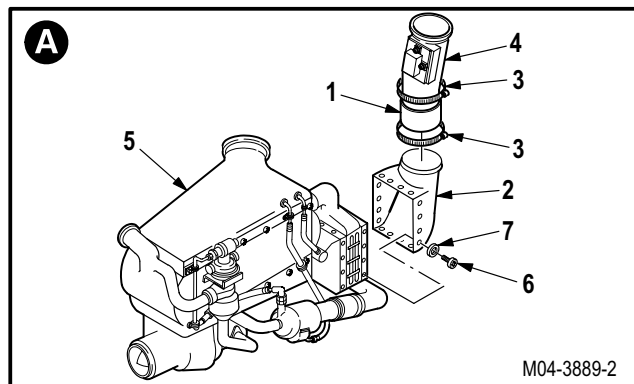
**13.5.4. Cleaning****a. Clean adhesive from ENCUC and duct (para 1.47).****b. Wipe removed and attaching parts with a clean rag.****13.5.5. Inspection****a. Check ENCUC ducts, hoses, and clamps for chafing, cracks, or wear (para 13.1).****b. Check removed and attaching parts for corrosion (para 1.49).****c. Check duct for loose or damaged nutplates (para 13.1).**

GO TO NEXT PAGE

---

**13.5. ENCU AIR OUTLET DUCT REPLACEMENT - continued**

---

13.5.6. Installation



- a. **Apply adhesive at mating areas and screw holes of ENCU (5) and new duct (2) to completely seal duct (2).** Use adhesive (item 16, App F).
- b. **Install duct (2) on ENCU (5).**
  - (1) Position duct (2) on ENCU (5).
  - (2) Install 16 screws (6) and washers (7).
- c. **Install sleeve (1) on duct (2).**
  - (1) Install two clamps (3) on duct (2).
  - (2) Center sleeve (1) over duct (2) and duct (4).
  - (3) Tighten clamps (3).
- d. **Allow adhesive to dry 24 HOURS at 65 °F minimum.**
- e. **Inspect (QA).**
- f. **Install ENCU (para 13.3).**

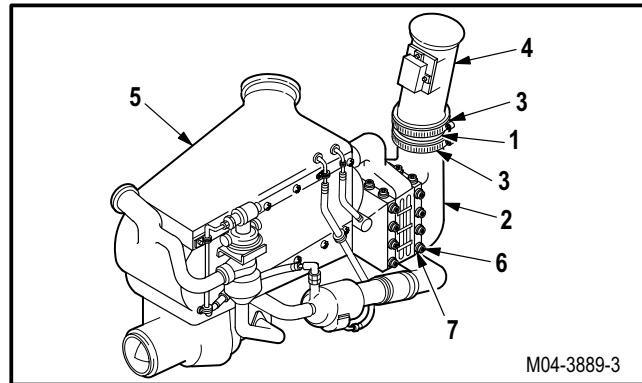

END OF TASK

**13.6. ENCUC TEMPERATURE CONTROL SHUTOFF VALVE REMOVAL/INSTALLATION**

13.6.1. Description

This task covers: Removal. Cleaning. Inspection. Installation.

13.6.2. Initial Setup

**Tools:**

- Aircraft mechanic's tool kit (item 376, App H)
- Light duty laboratory apron (item 27, App H)
- Industrial faceshield (item 129, App H)
- Chemical protective gloves (item 154, App H)
- 1 1/2 & 1 5/8-inch open end wrench (item 418, App H)

**Materials/Parts:**

- Packing (2)
- Petrolatum (item 138, App F)

**Personnel Required:**

- 67R Attack Helicopter Repairer
- 67R3F Attack Helicopter Repairer/Technical Inspector

**References:**

TM 1-1520-238-T

**Equipment Conditions:**

<u>Ref</u>	<u>Condition</u>
1.57	Helicopter safed
2.2	Access doors T250L, T250R, T290L, T290R, and L325 opened

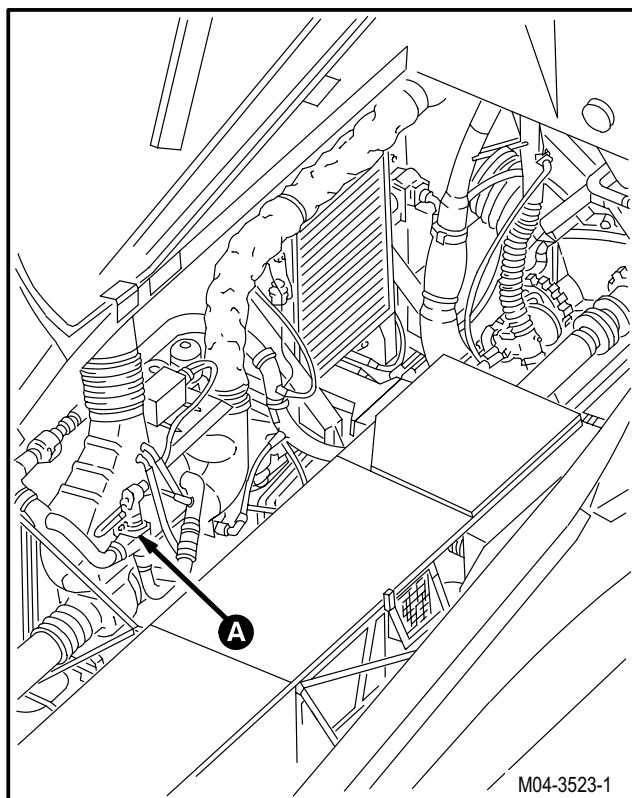

GO TO NEXT PAGE

**13.6. ENCUC TEMPERATURE CONTROL SHUTOFF VALVE REMOVAL/INSTALLATION - continued**

**13.6.3. Removal**

a. **Detach connector P287 (1) from receptacle (L39)J1 (2).**

b. **Remove temperature control tube (3) from nipple (4).**

(1) Hold nipple (4). Remove nut (5).

c. **Remove rigid tube (6) from ENCUC temperature control shutoff valve (7).**

(1) Remove nut (8). Use open end wrench.

(2) Remove compression sleeve (9).

d. **Remove shutoff valve (7) from ENCUC (10) and duct (11).**

(1) Remove two bolts (12) and washers (13).

(2) Remove shutoff valve (7).

(3) Remove and discard packing (14).

**NOTE**

If replacing shutoff valve, go to step e. If reinstalling valve, go to paragraph 13.6.4.

e. **Remove nipple (4) from ENCUC electrical control valve (15).**

(1) Hold electrical valve (15). Remove nipple (4).

(2) Remove and discard packing (16).

**13.6.4. Cleaning**

a. **Wipe removed and attaching parts with clean rag.**

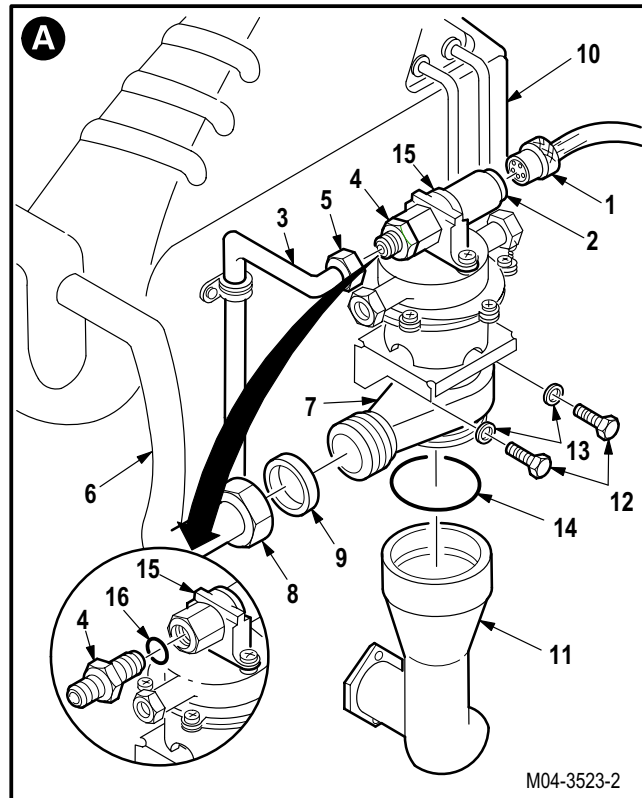

GO TO NEXT PAGE

---

**13.6. ENCU TEMPERATURE CONTROL SHUTOFF VALVE REMOVAL/INSTALLATION**

---

**13.6.5. Inspection**

- a. **Check compression sleeve and nipple for cracks, dents, or nicks** (para 13.1).
- b. **Check shutoff valve connections, mounts, and ducts for cracks, nicks, dents, and stripped or damaged threads** (para 13.1).
- c. **Check removed and attaching parts for corrosion** (para 1.49).
- d. **Check for loose or missing screws.** None allowed.
- e. **Check for cracked or dented bodies.** None allowed.
- f. **Check for scored or distorted flanges.** None allowed.
- g. **Check for damaged connector threads.** None allowed.
- h. **Check for bent, broken or missing connector pins.** None allowed.
- i. **Check for broken or missing lockwire.** None allowed.
- j. **Check identification plate for damage.** None allowed.
- k. **Check for worn or damaged coating and bare metal.** Touch-up as required.

GO TO NEXT PAGE

13.6. ENCUC TEMPERATURE CONTROL SHUTOFF VALVE REMOVAL/INSTALLATION - continued

13.6.6. Installation



**NOTE**

If shutoff valve was replaced, go to step a. If reinstalling valve, go to step b.

**a. Install nipple (4) on electrical valve (15).**

- (1) Lubricate new packing (16). Use petrolatum (item 138, App F).
- (2) Install packing (16) on nipple (4).
- (3) Hold electrical valve (15). Install nipple (4).

**b. Install new packing (14) on shutoff valve (7).**

- (1) Lubricate packing (14). Use petrolatum (item 138, App F).
- (2) Install packing (14) on shutoff valve (7).

**c. Install shutoff valve (7) on ENCUC (10) and duct (11).**

- (1) Install shutoff valve (7) on duct (11).
- (2) Position shutoff valve (7) on ENCUC (10).
- (3) Install two bolts (12) and washers (13).

**d. Install tube (6) on shutoff valve (7).**

- (1) Position compression sleeve (9) between tube (6) and shutoff valve (7).
- (2) Install nut (8). Use open end wrench.

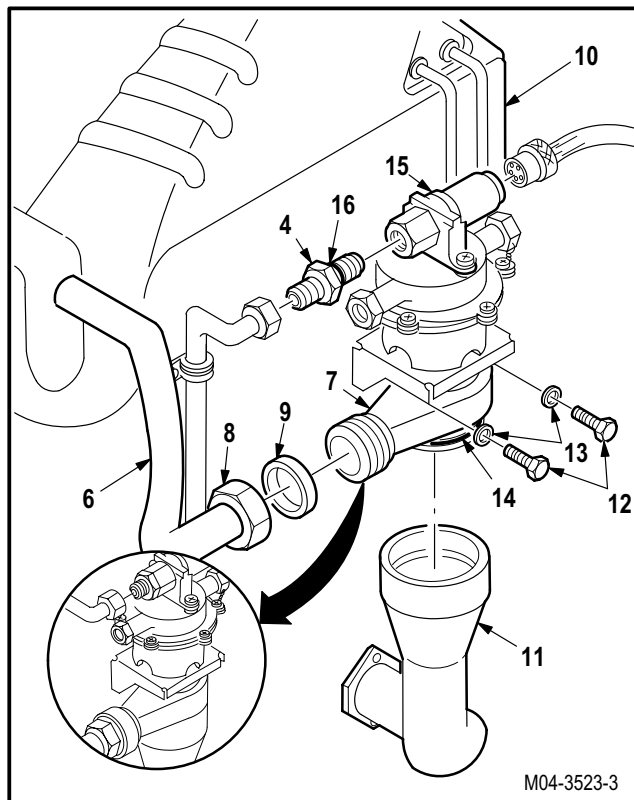

**e. Install tube (3) on nipple (4).**

- (1) Hold nipple (4). Install nut (5).

**f. Attach connector P287 (1) to receptacle (L39)J1 (2).**

**g. Inspect (QA).**

**h. Perform ECS maintenance operational check (TM 1-1520-238-T).**

**i. Secure access doors T250L, T250R, T290L, T290R, and L325 (para 2.2).**

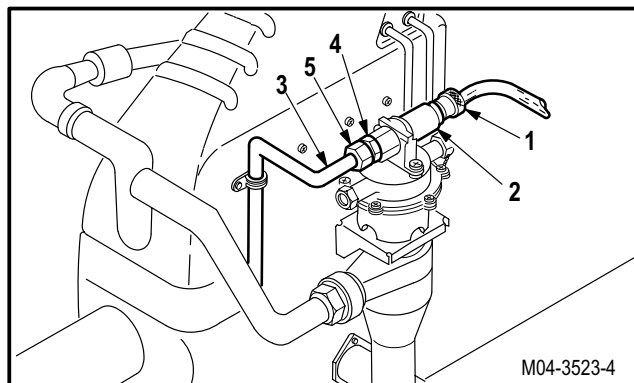

END OF TASK

**13.7. ENCUC ELECTRICAL CONTROL VALVE REMOVAL/INSTALLATION**

13.7.1. Description

This task covers: Removal. Cleaning. Inspection. Installation.

13.7.2. Initial Setup

**Tools:**

Aircraft mechanic's tool kit (item 376, App H)  
 Light duty laboratory apron (item 27, App H)  
 Industrial faceshield (item 129, App H)  
 Chemical protective gloves (item 154, App H)

**References:**

TM 1-1520-238-T  
 ■ TM 55-1500-323-24

**Materials/Parts:**

Packing (2)  
 Petrolatum (item 138, App F)

**Equipment Conditions:**

**Personnel Required:**

67R Attack Helicopter Repairer  
 67R3F Attack Helicopter Repairer/Technical Inspector

<u>Ref</u>	<u>Condition</u>
1.57	Helicopter safed
2.2	Access doors T250L, T250R, T290L, T290R, and L325 opened

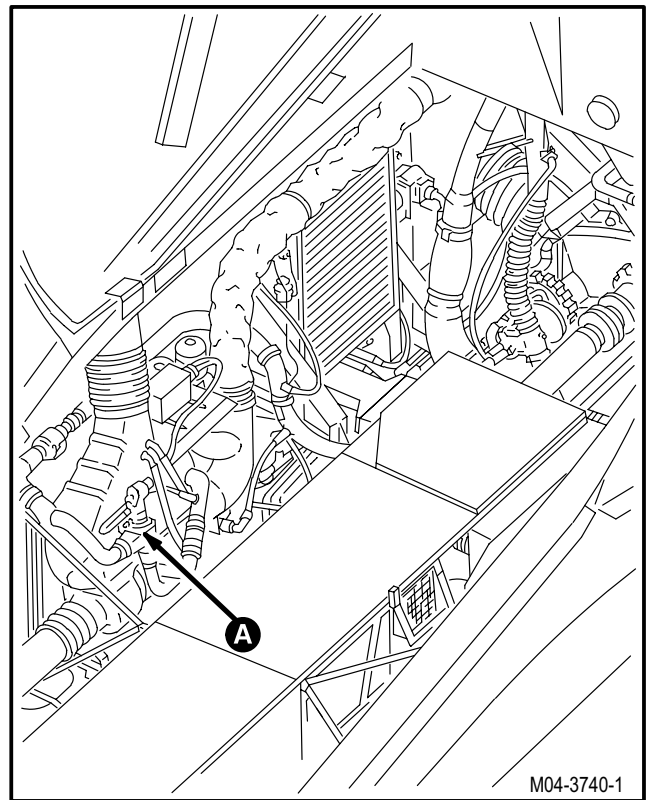

M04-3740-1

GO TO NEXT PAGE

**13.7. ENCUC ELECTRICAL CONTROL VALVE REMOVAL/INSTALLATION - continued**

**13.7.3. Removal**

- a. **Detach connector P287 (1) from receptacle (L39)J1 (2).**
- b. **Remove tube (3) from ENCUC electrical control valve (4).**
  - (1) Hold nipple (5). Remove nut (6).
- c. **Remove electrical valve (4) from ENCUC temperature control shutoff valve (7).**
  - (1) Remove two screws (8) and washers (9).
  - (2) Remove electrical valve (4).
  - (3) Remove and discard packing (10) from port (11) in shutoff valve (7).

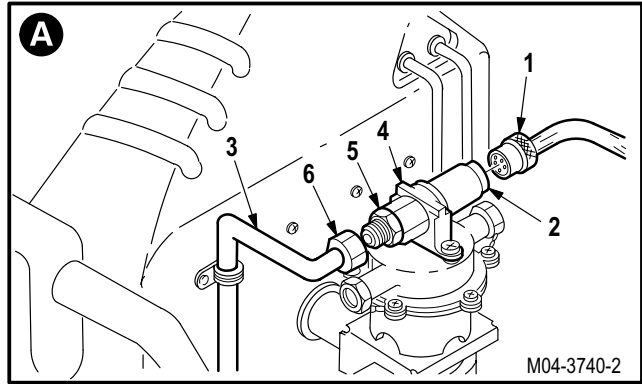

**NOTE**

If replacing electrical valve, go to step d.  
 If reinstalling valve, go to paragraph 13.7.4.

- d. **Remove nipple (5) from electrical valve (4).**
  - (1) Hold electrical valve (4). Remove nipple (5).
  - (2) Remove and discard packing (12).

**13.7.4. Cleaning**

- a. **Wipe removed and attaching parts with a clean rag.**

**13.7.5. Inspection**

- a. **Check nipple and screws for cracks, nicks, and stripped or damaged threads (para 13.1).**
- b. **Check removed and attaching parts for corrosion (para 1.49).**
- c. **Check for cracked or dented body. None allowed.**
- d. **Check for damaged connector threads. None allowed.**
- e. **Check for cracks, corrosion, and broken, bent, or damaged pins (TM 55-1500-323-24).**

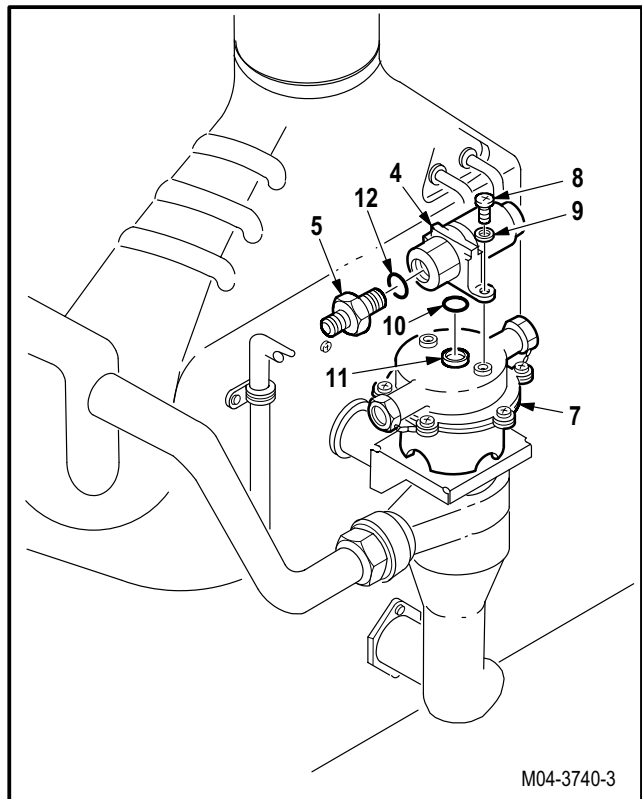

GO TO NEXT PAGE



**13.7. ENCU ELECTRICAL CONTROL VALVE REMOVAL/INSTALLATION - continued**

13.7.6. Installation



**NOTE**

If replacing electrical valve, go to step a.  
If installing valve, go to step b.

**a. Install nipple (5) on electrical valve (4).**

- (1) Lubricate new packing (12). Use petrolatum (item 138, App F).
- (2) Install packing (12) on nipple (5).
- (3) Hold electrical valve (4). Install nipple (5).

**b. Install electrical valve (4) on shutoff valve (7).**

- (1) Lubricate new packing (10). Use petrolatum (item 138, App F).
- (2) Install packing (10) in port (11) on shutoff valve (7).
- (3) Position electrical valve (4) on shutoff valve (7).
- (4) Install two screws (8) and washers (9).

**c. Install tube (3) on electrical valve (4).**

- (1) Hold nipple (5). Install nut (6).

**d. Attach connector P287 (1) to receptacle (L39)J1 (2).**

**e. Inspect (QA).**

**f. Perform ECS maintenance operational check (TM 1-1520-238-T).**

**g. Secure access doors T250L, T250R, T290L, T290R, and L325 (para 2.2).**

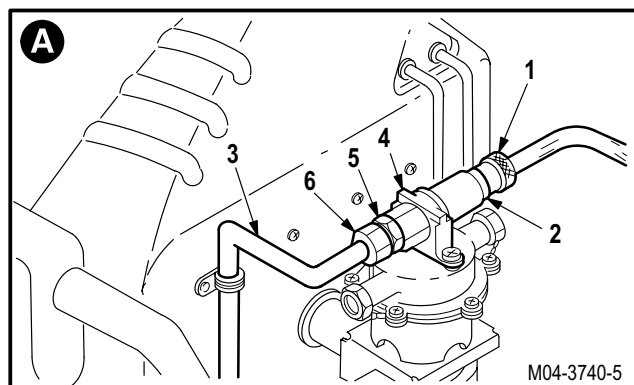
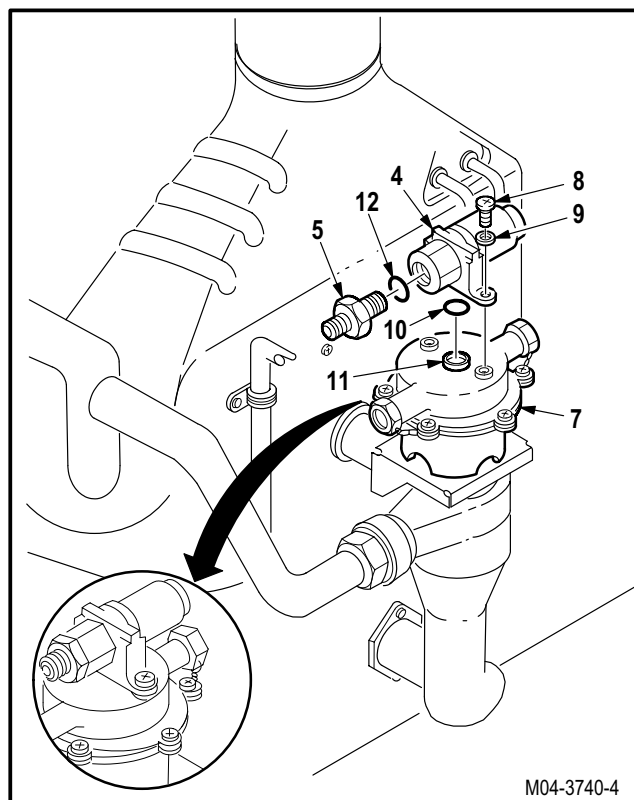

END OF TASK

---

**13.8. ENCU TEMPERATURE CONTROL SHUTOFF VALVE/ELECTRICAL CONTROL VALVE CLEANING**

---

13.8.1. Description

This task covers: Cleaning.

---

13.8.2. Initial Setup

**Tools:**

Aircraft mechanic's tool kit (item 376, App H)  
 Light duty laboratory apron (item 27, App H)  
 Industrial faceshield (item 129, App H)  
 Chemical protective gloves (item 154, App H)  
 Air blow gun (item 158, App H)

**Materials/Parts:**

Packing (2)  
 Cloth (item 52, App F)  
 Petrolatum (item 138, App F)  
 Wire (item 226, App F)

**Personnel Required:**

67R Attack Helicopter Repairer  
 67R3F Attack Helicopter Repairer/Technical Inspector

**Equipment Conditions:**

<u>Ref</u>	<u>Condition</u>
13.6	ENCU temperature control shutoff valve removed
13.7	ENCU electrical control valve removed

---

**WARNING**

**Compressed air used for cleaning can create airborne particles that may enter the eyes. Pressure shall not exceed 30 PSI. Personnel are required to wear safety goggles for eye protection.**

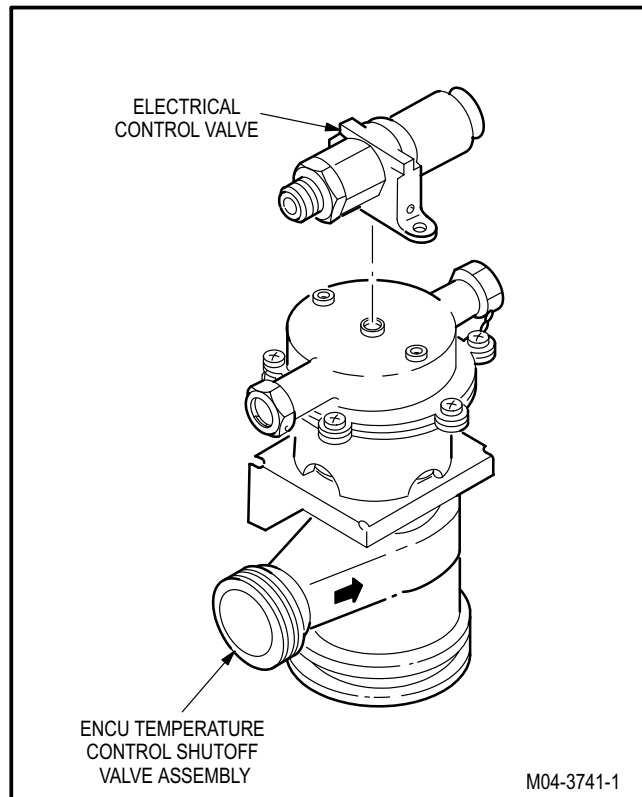

GO TO NEXT PAGE

**13.8. ENCU TEMPERATURE CONTROL SHUTOFF VALVE/ELECTRICAL CONTROL VALVE  
CLEANING - continued**

13.8.3. Cleaning

- a. **Wipe removed and attaching parts.** Use cloth (item 52, App F).
- b. **Remove two plugs (1) from ENCU temperature control shutoff valve actuator cover (2).**

- (1) Remove lockwire.
- (2) Remove two plugs (1).
- (3) Remove and discard two packings (3).

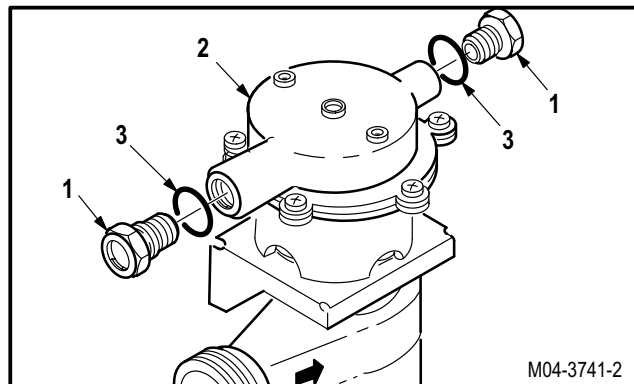

**CAUTION**

Use low pressure compressed air only. Pressure shall not exceed 30 PSI. Failure to do so could damage components.



- c. **Blow air inside of ENCU electrical control valve (4) at ports (5), (6), and (7) with dry compressed air.** Use air blow gun.

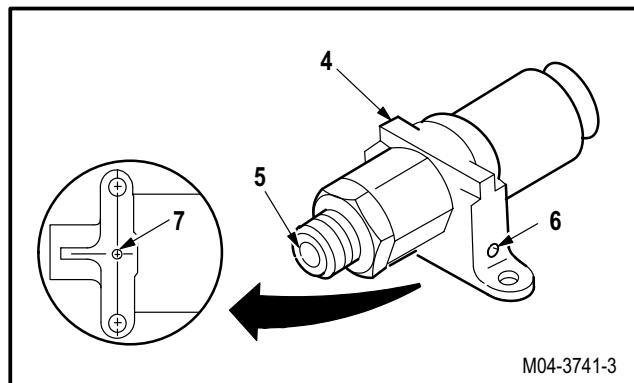

- d. **Blow air inside of actuator cover (2) at ports (8) and (9) with dry compressed air.** Use air blow gun.

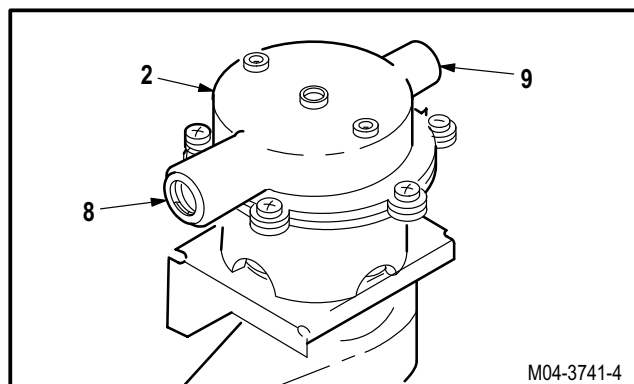

GO TO NEXT PAGE

**13.8. ENCU TEMPERATURE CONTROL SHUTOFF VALVE/ELECTRICAL CONTROL VALVE  
CLEANING - continued**



**e. Blow air inside of ENCU temperature control shutoff valve (10) with dry compressed air.**

- (1) Hold shutoff valve (10) horizontal with air inlet port (11) pointed up.
- (2) Blow air inside shutoff valve (10) at port (11) and air outlet port (12) with dry compressed air. Use air blow gun.
- (3) Actuate shutoff valve (10) several times by inserting a pin punch through port (13) on actuator cover (2).
- (4) Blow dry inside of shutoff valve (10) at ports (11) and (12) with dry compressed air. Use air blow gun.

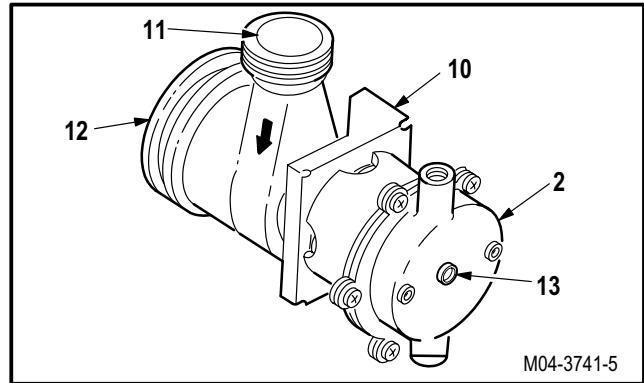

**f. Install two plugs (1) on actuator cover (2).**

- (1) Lubricate two new packings (3). Use petrolatum (item 138, App F).
- (2) Install two packings (3) on two plugs (1).
- (3) Install two plugs (1) on actuator cover (2).

**g. Lockwire two plugs (1) to actuator cover (2).  
Use wire (item 226, App F).**

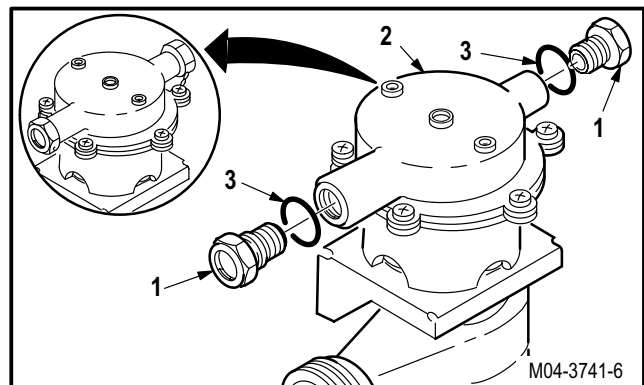

**h. Inspect (QA).**

**i. Install ENCU electrical control valve (para 13.7).**

**j. Install ENCU temperature control shutoff valve (para 13.6).**

END OF TASK

### 13.9. ENCUCOOLING TURBINE ASSEMBLY REMOVAL/INSTALLATION

#### 13.9.1. Description

This task covers: Removal. Cleaning. Inspection. Installation.

#### 13.9.2. Initial Setup

##### Tools:

Aircraft mechanic's tool kit (item 376, App H)  
 Light duty laboratory apron (item 27, App H)  
 Industrial faceshield (item 129, App H)  
 Chemical protective gloves (item 154, App H)  
 30 - 150 inch-pound 1/4-inch drive click type torque wrench (item 435, App H)

##### Personnel Required:

67R Attack Helicopter Repairer  
 67R3F Attack Helicopter Repairer/Technical Inspector

##### References:

TM 1-1520-238-T

##### Materials/Parts:

Packing (3)  
 Petrolatum (item 138, App F)

##### Equipment Conditions:

Ref	Condition
13.3	ENCUCOOLING TURBINE ASSEMBLY REMOVED

#### 13.9.3. Removal

a. Remove duct assembly (1) from ENCUCOOLING turbine assembly (2).

- (1) Remove two screws (3) and washers (4).
- (2) Rotate duct (1) clockwise to clear turbine (2).
- (3) Remove duct (1).
- (4) Remove and discard packings (5) and (6).

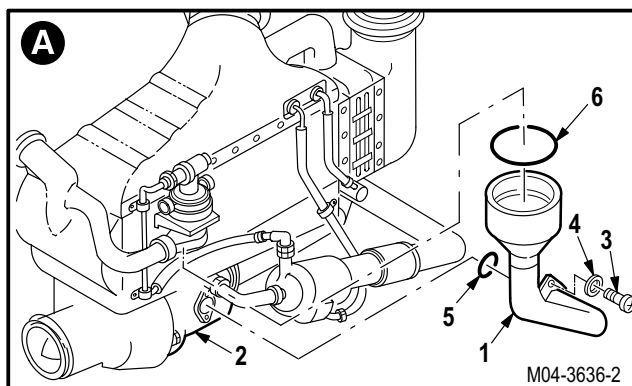
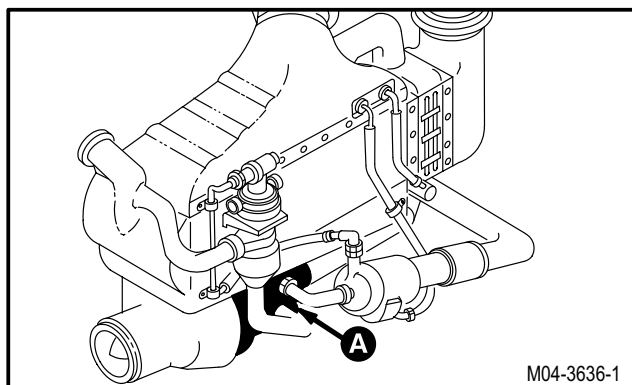

GO TO NEXT PAGE

**13.9. ENCUCOOLING TURBINE ASSEMBLY REMOVAL/INSTALLATION - continued**

**b. Remove hose (7) from turbine (2).**

- (1) Loosen two clamps (8) and (9) from hose (7).
- (2) Slide hose (7) and clamps (8) and (9) from turbine (2) on duct (10).
- (3) Remove and discard packing (11).

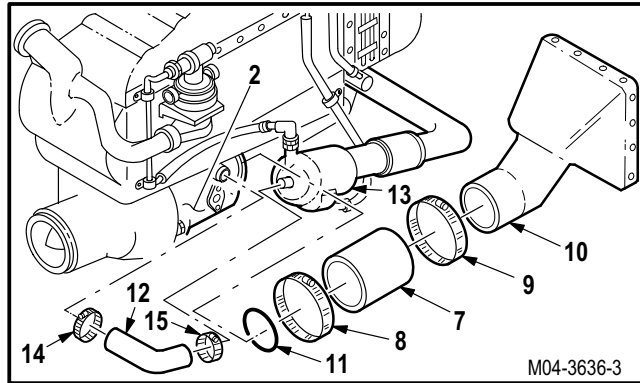

**c. Remove hose (12) from turbine (2) and water extractor assembly (13).**

- (1) Loosen two clamps (14) and (15) from hose (12).
- (2) Remove hose (12) and clamps (14) and (15).

**d. Remove turbine (2) from ENCUCOOLING (16).**

- (1) Remove four bolts (17) and washers (18).
- (2) Remove turbine (2).

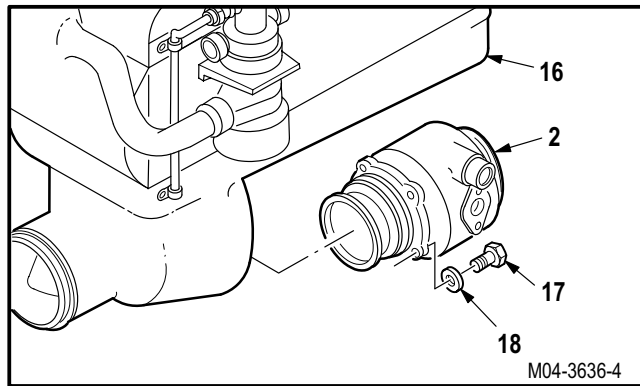

**13.9.4. Cleaning**

- a. **Wipe removed and attaching parts with a clean rag.**

**13.9.5. Inspection**

- a. **Check ducts for chafing, cracks, dents, nicks, or scratches** (para 13.1).
- b. **Check removed and attaching parts for corrosion** (para 1.49).
- c. **Check turbine for loose, missing or damaged hardware** (para 13.1).

**13.9.6. Installation**

- a. **Install turbine (2) on ENCUCOOLING (16). Torque four bolts (17) to 80 INCH-POUNDS.**

- (1) Aline turbine (2) with ENCUCOOLING (16).
- (2) Install four bolts (17) and washers (18).
- (3) Torque four bolts (17) to **80 INCH-POUNDS**. Use torque wrench.

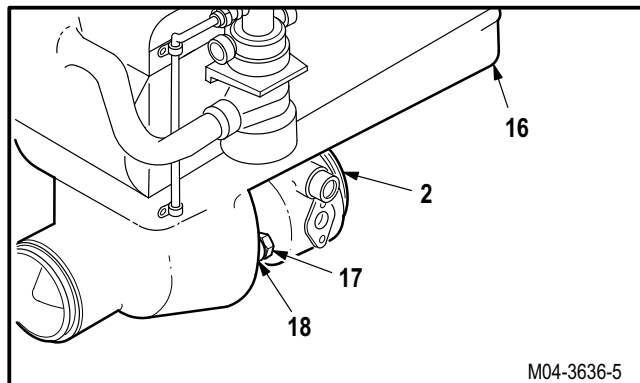

GO TO NEXT PAGE

**13.9. ENCU COOLING TURBINE ASSEMBLY REMOVAL/INSTALLATION - continued**

**b. Install hose (12) on turbine (2) and extractor assembly (13).**

- (1) Install hose (12) and clamps (14) and (15) on turbine (2) and extractor assembly (13).
- (2) Tighten clamps (14) and (15).

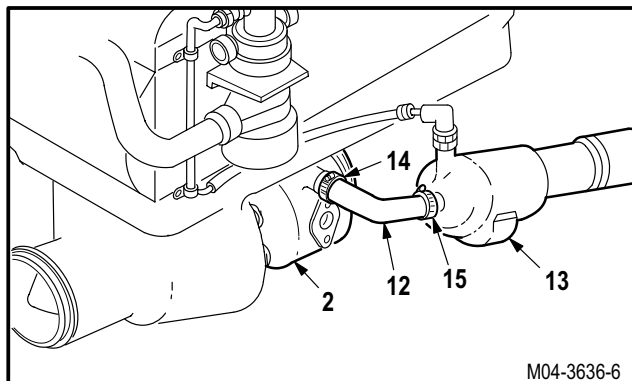

**c. Install hose (7) on turbine (2).**

- (1) Lubricate new packing (11). Use petrolatum (item 138, App F).
- (2) Install packing (11) on turbine (2).
- (3) Slide hose (7) and clamps (8) and (9) from duct (10) on turbine (2).
- (4) Tighten clamps (8) and (9).

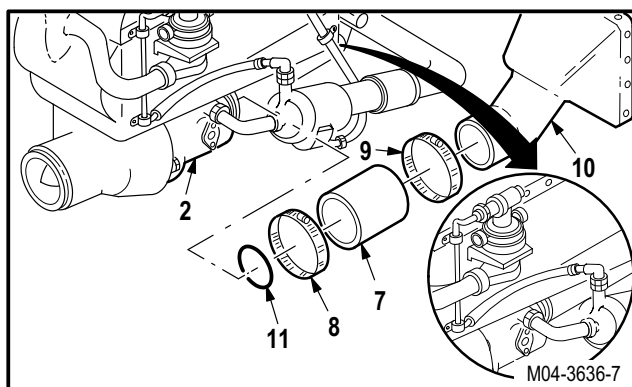

**d. Install duct (1) on turbine (2).**

- (1) Lubricate new packings (5) and (6). Use petrolatum (item 138, App F).
- (2) Install packings (5) and (6) on duct (1).
- (3) Install duct (1) on ENCU temperature control valve (19).
- (4) Rotate duct (1) counterclockwise until duct (1) mates with turbine (2).
- (5) Install two screws (3) and washers (4).

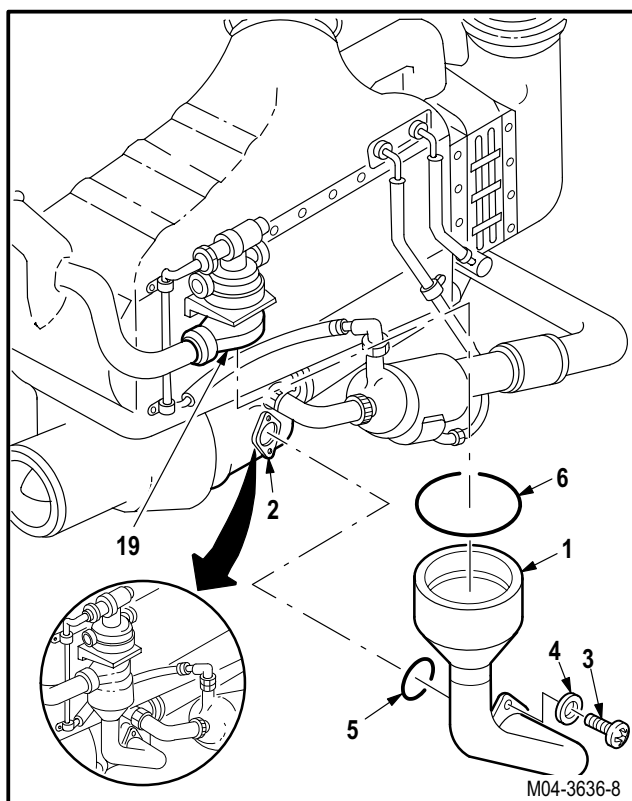

**e. Inspect (QA).**

**f. Service turbine assembly (para 1.52).**

**g. Install ENCU (para 13.3).**

**h. Perform ECS maintenance operational check (TM 1-1520-238-T).**

END OF TASK

---

## 13.10. ENCU WATER EXTRACTOR ASSEMBLY REPLACEMENT

---

### 13.10.1. Description

This task covers: Removal. Cleaning. Inspection. Installation.

---

### 13.10.2. Initial Setup

#### Tools:

Aircraft mechanic's tool kit (item 376, App H)  
Light duty laboratory apron (item 27, App H)  
Industrial faceshield (item 129, App H)  
Chemical protective gloves (item 154, App H)

#### References:

TM 1-1520-238-T  
■ TM 1-1500-204-23

#### Materials/Parts:

Packing  
Petrolatum (item 138, App F)

#### Personnel Required:

67R Attack Helicopter Repairer  
67R3F Attack Helicopter Repairer/Technical  
Inspector

#### Equipment Conditions:

<u>Ref</u>	<u>Condition</u>
1.57	Helicopter safed
2.84	Center aft catwalk panel removed

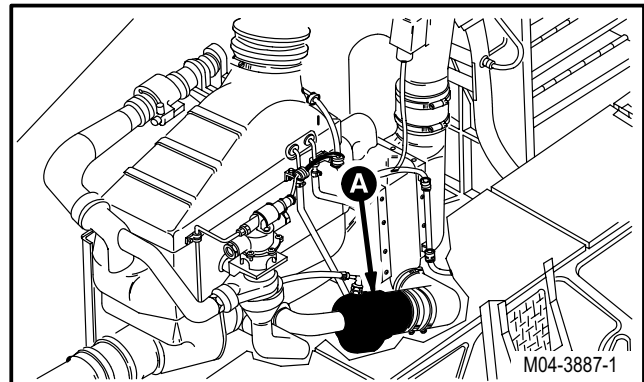

GO TO NEXT PAGE



### 13.10. ENCUC WATER EXTRACTOR ASSEMBLY REPLACEMENT - continued

#### 13.10.3. Removal

a. **Remove hose (1) from water extractor assembly (2).**

- (1) Loosen clamp (3) from hose (1).
- (2) Remove hose (1) and clamp (3).

b. **Remove hose (4) from elbow (5).**

- (1) Loosen clamp (6) from hose (4).
- (2) Remove hose (4) and clamp (6).

c. **Remove extractor (2) from hoses (7) and (8).**

- (1) Loosen two clamps (9) and (10) from hoses (7) and (8).
- (2) Remove extractor (2) and clamps (9) and (10).

d. **Remove elbow (5) from extractor (2).**

- (1) Loosen nut (11).
- (2) Remove and retain elbow (5).
- (3) Remove and discard packing (12).

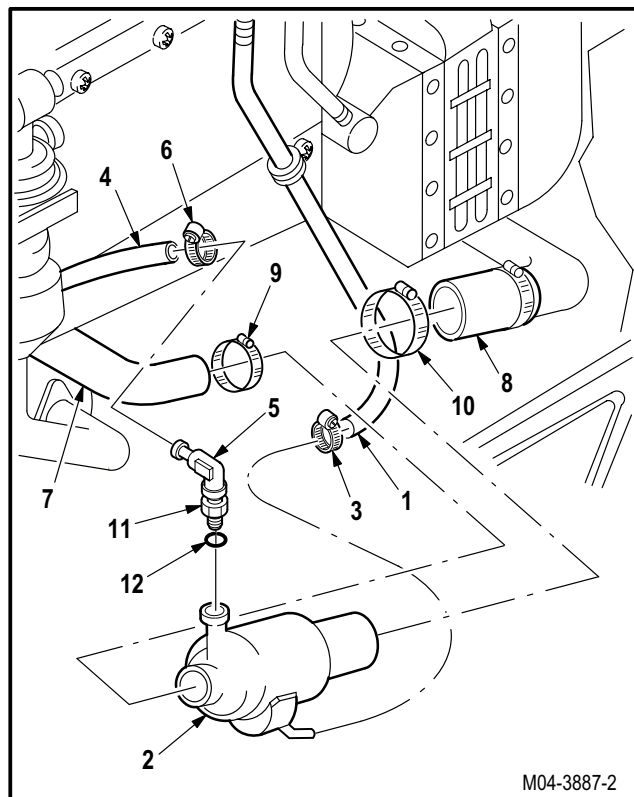

#### 13.10.4. Cleaning

a. **Wipe removed and attaching parts with a clean rag.**

#### 13.10.5. Inspection

- a. **Check ENCUC ducts, hoses, and clamps for chafing, cracks, or wear** (para 13.1).
- b. **Check removed and attaching parts for corrosion** (para 1.49).
- c. **Check extractor for cracks, punctures, and broken welds.** None allowed.
- d. **Check extractor swirl vanes for broken or cracked welds.** None allowed.
- e. **Check extractor for minor dents, nicks, scratches and bent ducts.** Repair minor surface damage (TM 1-1500-204-23).

GO TO NEXT PAGE

**13.10. ENCU WATER EXTRACTOR ASSEMBLY REPLACEMENT - continued**

13.10.6. Installation



**a. Install elbow (5) on new extractor (2).**

- (1) Lubricate new packing (12). Use petrolatum (item 138, App F).
- (2) Install packing (12) on elbow (5).
- (3) Install and align elbow (5) on extractor (2).
- (4) Tighten nut (11).

**b. Install extractor (2) on hoses (7) and (8).**

- (1) Install clamps (9) and (10) on hoses (7) and (8).
- (2) Install and position extractor (2) on hoses (7) and (8).
- (3) Tighten clamps (9) and (10) on hoses (7) and (8).

**c. Install hose (4) on elbow (5).**

- (1) Install hose (4) and clamp (6) on elbow (5).
- (2) Tighten clamp (6).

**d. Install hose (1) on extractor (2).**

- (1) Install hose (1) and clamp (3) on extractor (2).
- (2) Tighten clamp (3).

**e. Inspect (QA).**

**f. Perform ECS maintenance operational check (TM 1-1520-238-T).**

**g. Install center aft catwalk panel (para 2.84).**

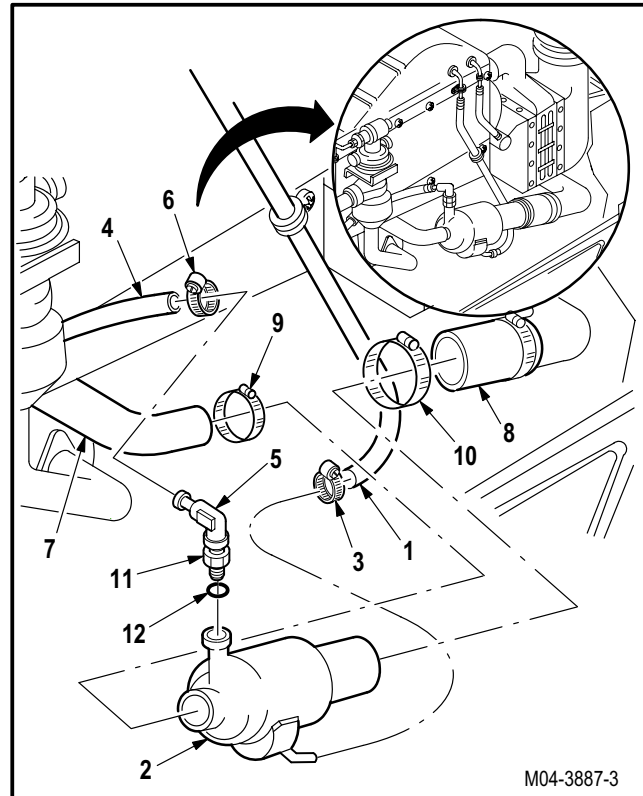

M04-3887-3

END OF TASK

**13.11. ENCU TEMPERATURE CONTROL SENSOR REMOVAL/INSTALLATION**

13.11.1. Description

This task covers: Removal. Cleaning. Inspection. Installation.

13.11.2. Initial Setup

**Tools:**

- Aircraft mechanic's tool kit (item 376, App H)
- Light duty laboratory apron (item 27, App H)
- Chemical protective gloves (item 154, App H)
- Adjustable air filtering respirator (item 262, App H)

**References:**

- TM 1-1520-238-T
- TM 55-1500-323-24

**Materials/Parts:**

- Gasket
- Sealing compound (item 176, App F)

**Personnel Required:**

- 67R Attack Helicopter Repairer
- 67R3F Attack Helicopter Repairer/Technical Inspector

**Equipment Conditions:**

<u>Ref</u>	<u>Condition</u>
1.57	Helicopter safed
2.2	Access doors T250L, T250R, T290L, T290R, and L325 opened

13.11.3. Removal

a. **Detach connector P285 (1) from receptacle (A43)J1 (2).**

- (1) Remove sealing compound from connector (1).
- (2) Detach connector P285 (1).

b. **Remove temperature control sensor (3) from air duct (4).**

- (1) Remove sealing compound from sensor (3), screws (5), and washers (6).
- (2) Remove three screws (5) and washers (6).
- (3) Remove sensor (3) and gasket (7).
- (4) Discard gasket (7).

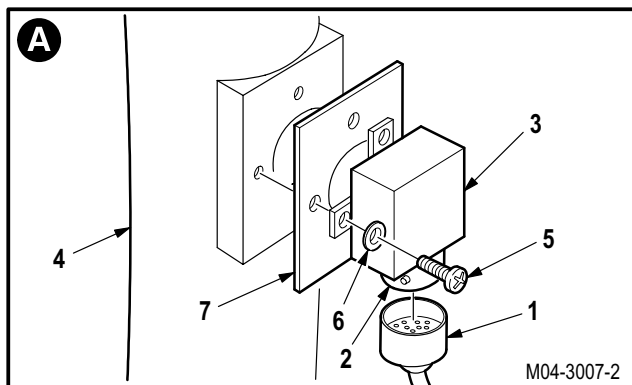
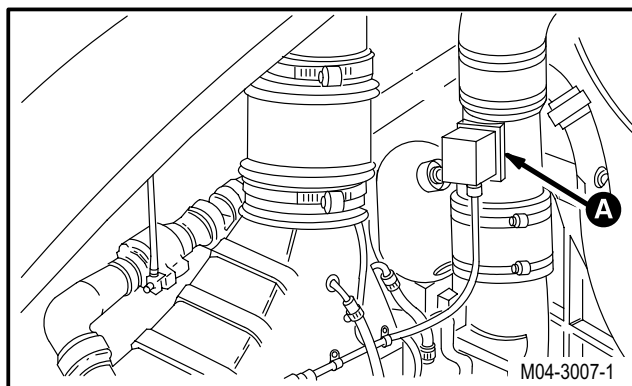

13.11.4. Cleaning

a. **Clean sealing compound from removed parts (para 1.47).**

GO TO NEXT PAGE

**13.11. ENCU TEMPERATURE CONTROL SENSOR REMOVAL/INSTALLATION - continued**

13.11.5. Inspection

- a. **Check air duct for cracks** (para 13.1).
- b. **Check duct nutplates for loose rivets and stripped or damaged threads** (para 13.1).
- c. **Check removed and attaching parts for corrosion** (para 1.49).
- d. **Check sensor for loose, missing or damaged hardware.** None allowed.
- e. **Check sensor for damage, overheating, and paint damage.** None allowed.
- f. **Check sensor identification plate** (para 13.1).
- g. **Check sensor receptacle for cracks corrosion, and broken, bent, or damaged pins** (TM 55-1500-323-24).

13.11.6. Installation

- a. **Install sensor (3) on air duct (4).**
  - (1) Position sensor (3) and new gasket (7) on duct (4).
  - (2) Install three screws (5) and washers (6).
- b. **Attach connector P285 (1) to receptacle (A43)J1 (2).**



- c. **Apply sealing compound to edges of sensor (3), screws (5), washers (6), and around edge of connector P285 (1).** Use sealing compound (item 176, App F).
- d. **Inspect (QA).**
- e. **Perform ECS maintenance operational check** (TM 1-1520-238-T).
- f. **Secure access doors T250L, T250R, T290L, T290R, and L325** (para 2.2).

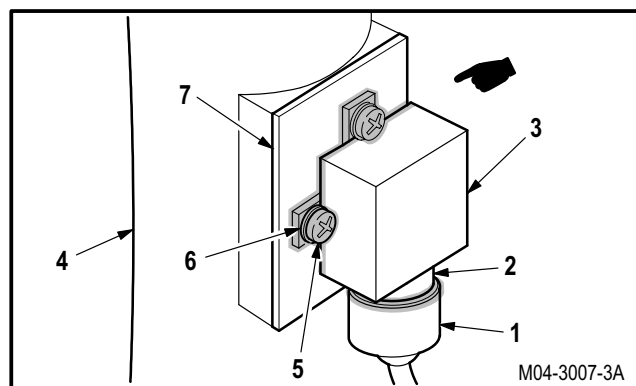

END OF TASK

**13.12. ENCU FILTER REMOVAL/INSTALLATION**

13.12.1. Description

This task covers: Removal. Cleaning. Inspection. Servicing. Installation.

13.12.2. Initial Setup

**Tools:**

- Aircraft mechanic's tool kit (item 376, App H)
- Light duty laboratory apron (item 27, App H)
- Chemical protective gloves (item 154, App H)
- Adjustable air filtering respirator (item 262, App H)

**Materials/Parts:**

- Brush (item 34, App F)
- Air filter oil (item 129A, App F)
- Dishwashing compound (item 72, App F)

**Personnel Required:**

- 67R Attack Helicopter Repairer

**Equipment Conditions:**

<u>Ref</u>	<u>Condition</u>
1.57	Helicopter safed
2.2	Access doors T250L, T250R, T290L, T290R, and L325 opened

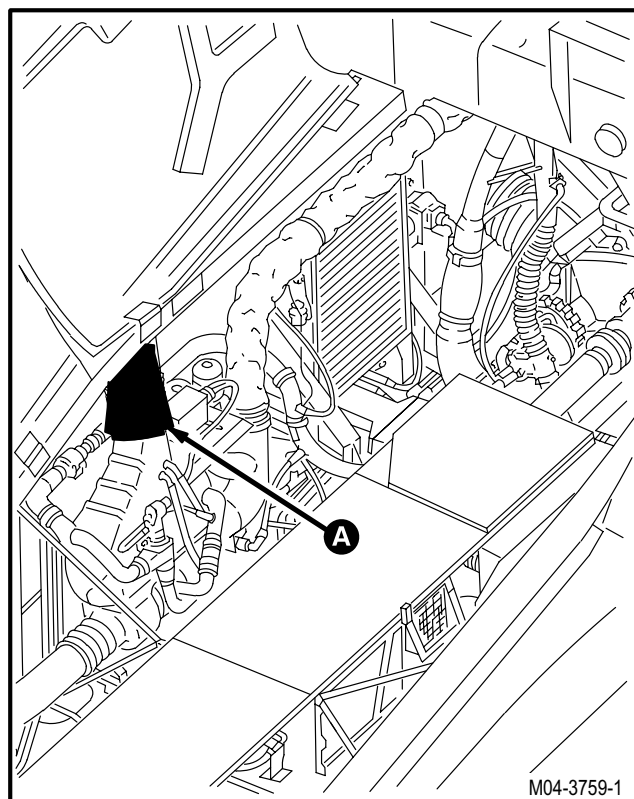

M04-3759-1

GO TO NEXT PAGE

---

**13.12. ENCUC FILTER REMOVAL/INSTALLATION - continued**

---

13.12.3. Removal

a. **Remove filter (1) from ENCUC air inlet (2).**

- (1) Loosen clamp (3).
- (2) Remove filter (1) and clamp (3).
- (3) Discard filter (1).

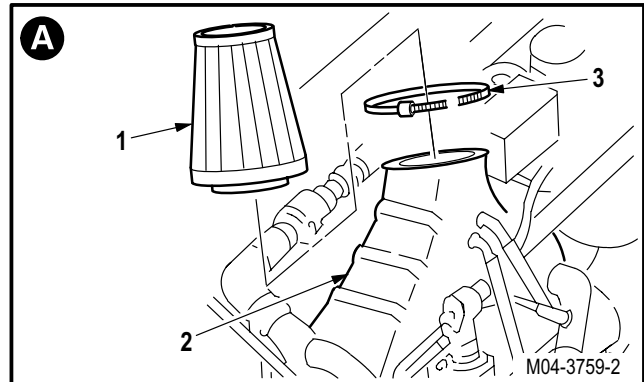

13.12.4. Cleaning

**NOTE**

Filter should be cleaned only if replacement filter is not available.

a. **Tap filter to dislodge embedded dirt, then gently brush.** Use brush (item 34, App F).

**CAUTION**

To prevent damage to filter, do not use gasoline, steam cleaning, caustic cleaning solutions, strong detergents, high pressure water, or cleaning solvents to clean filter.

b. **Soak filter in mild detergent solution for 10 MINUTES.** Use dishwashing compound (item 72, App F).

c. **Flush filter with low pressure water from clean side to dirty side.**

- (1) Shake off excess water.

**CAUTION**

To prevent damage to filter, do not use compressed air or other artificial sources to dry filter.

d. **Air dry filter.**

GO TO NEXT PAGE

---

**13.12. ENCUC FILTER REMOVAL/INSTALLATION - continued**

---

13.12.5. Inspection

- a. **Check filter for damage and cleanliness** (para 13.1).
- b. **Check ENCUC air inlet for obstructions.** None allowed.

13.12.6. Servicing

**CAUTION**

Do not use filter without air filter oil. Filter will not stop dirt without air filter oil.

a. **Apply air filter oil on filter (1).**

- (1) Squeeze air filter oil down into the bottom and along each pleat. Only one pass per pleat. Use air filter oil (item 129A, App F).
- (2) Wait **20 MINUTES** and re-apply air filter oil to any white spots.

13.12.7. Installationa. **Install filter (1) on ENCUC air inlet (2).**

- (1) Install filter (1) and clamp (3) on inlet (2).
- (2) Tighten clamp (3).

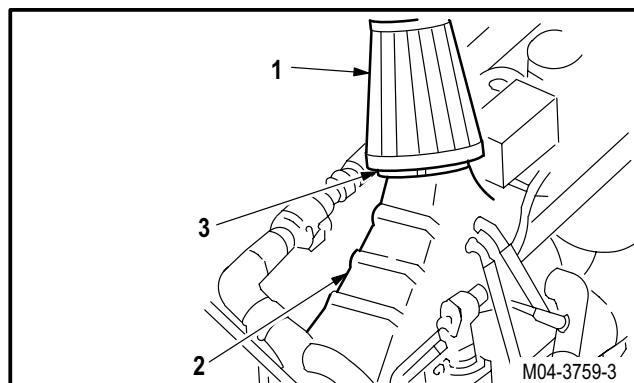
b. **Secure access doors T250L, T250R, T290L, T290R, and L325** (para 2.2).

END OF TASK

---

### 13.13. ENCU OVERBOARD EXHAUST DUCT REMOVAL/INSTALLATION

---

#### 13.13.1. Description

This task covers: Removal. Cleaning. Inspection. Installation.

---

#### 13.13.2. Initial Setup

##### **Tools:**

Aircraft mechanic's tool kit (item 376, App H)  
Light duty laboratory apron (item 27, App H)  
Chemical protective gloves (item 154, App H)  
Adjustable air filtering respirator (item 262, App H)

##### **Materials/Parts:**

Sealing compound (item 174, App F)

##### **Personnel Required:**

67R Attack Helicopter Repairer  
67R3F Attack Helicopter Repairer/Technical Inspector

##### **Equipment Conditions:**

<u>Ref</u>	<u>Condition</u>
1.57	Helicopter safed
2.2	Access doors T250L, T250R, T290L, T290R, and L325 opened

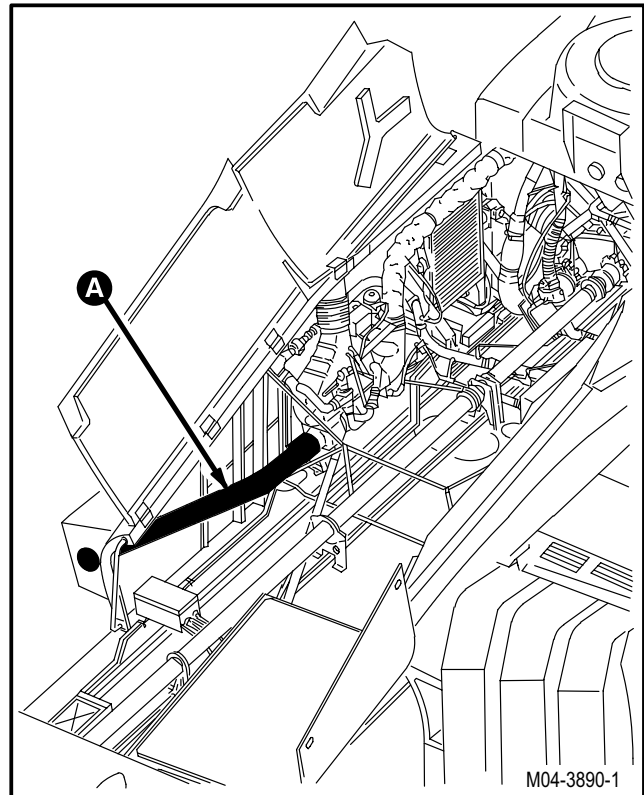

GO TO NEXT PAGE



---

**13.13. ENCU OVERBOARD EXHAUST DUCT REMOVAL/INSTALLATION - continued**

---

**13.13.3. Removal****a. Remove discharge duct (1) from ENCU (2) and overboard exhaust duct (3).**

- (1) Loosen two clamps (4) from hose (5).
- (2) Slide clamps (4) and hose (5) on duct (1).
- (3) Loosen two clamps (6) from hose (7).
- (4) Slide clamps (6) and hose (7) on duct (1).
- (5) Remove duct (1).

**b. Remove duct (3) from airframe (8).**

- (1) Remove six screws (9) and washers (10) from duct (3).
- (2) Remove duct (3).

**13.13.4. Cleaning****a. Clean sealing compound from ENCU and duct assembly (para 1.47).****b. Wipe removed and attaching parts with a clean rag.****13.13.5. Inspection**

- a. **Check ENCU ducts, hoses, and clamps for chafing, cracks, or wear (para 13.1).**
- b. **Check overboard exhaust duct nutplates for loose rivets and stripped or damaged threads (para 13.1).**
- c. **Check removed and attaching parts for corrosion (para 1.49).**

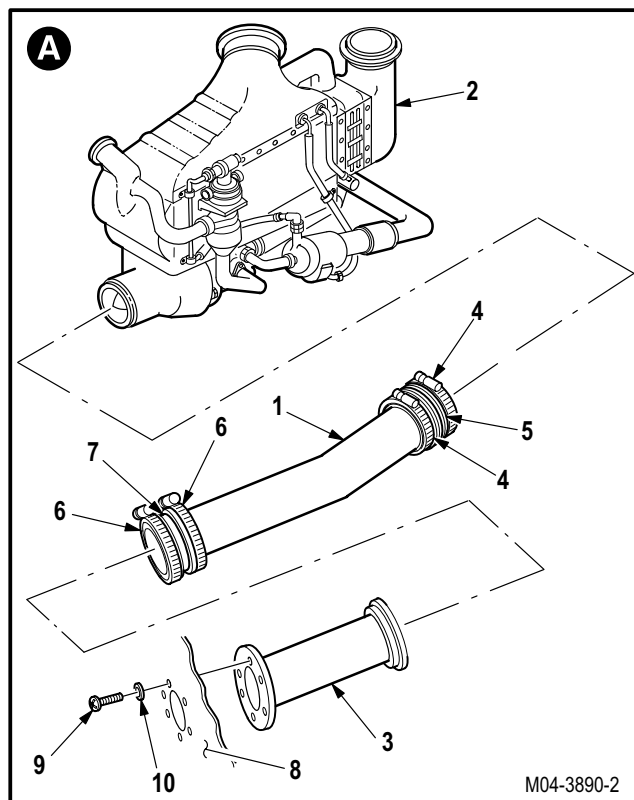

GO TO NEXT PAGE

**13.13. ENCU OVERBOARD EXHAUST DUCT REMOVAL/INSTALLATION - continued**

13.13.6. Installation



- a. **Apply sealing compound to mating areas of duct (3) and airframe (8).** Use sealing compound (item 174, App F).
- b. **Install duct (3) on airframe (8).**
  - (1) Position duct (3) on airframe (8).
  - (2) Install six screws (9) and washers (10) through airframe (8) into duct (3).
- c. **Install duct (1) on ENCU (2) and duct (3).**
  - (1) Position duct (1) between ENCU (2) and duct (3).
  - (2) Slide and center hose (5) over duct (1) and ENCU (2).
  - (3) Slide and center hose (7) over duct (1) and duct (3).
  - (4) Tighten two clamps (4) on hose (5).
  - (5) Tighten two clamps (6) on hose (7).
- d. **Allow sealing compound to dry 24 HOURS at 65 °F minimum.**
- e. **Inspect (QA).**
- f. **Secure access doors T250L, T250R, T290L, T290R, and L325 (para 2.2).**

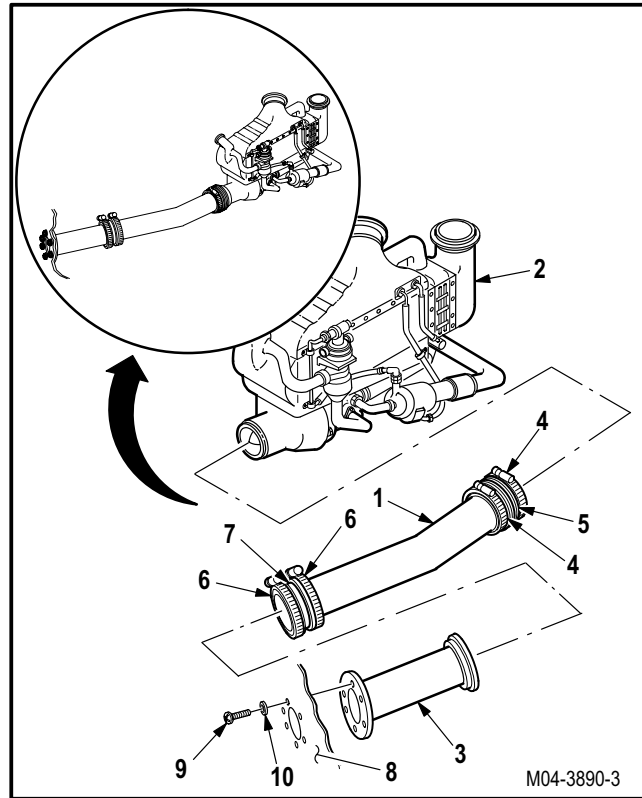

END OF TASK

**13.14. ENCUC SUPPORT REMOVAL/INSTALLATION**

13.14.1. Description

This task covers: Removal. Cleaning. Inspection. Installation.

13.14.2. Initial Setup

**Tools:**

- Aircraft mechanic's tool kit (item 376, App H)
- Electrical tool kit (item 378, App H)
- Light duty laboratory apron (item 27, App H)
- Chemical protective gloves (item 154, App H)
- Multimeter (item 215, App H)
- Adjustable air filtering respirator (item 262, App H)
- 30 - 150 inch-pound 1/4-inch drive click type torque wrench (item 435, App H)

**Materials/Parts:**

- Sealing compound (item 175, App F)

**Personnel Required:**

- 67R Attack Helicopter Repairer
- 68X Armament/Electrical System Repairer
- 67R3F Attack Helicopter Repairer/Technical Inspector

**References:**

- TM 55-1500-323-24

**Equipment Conditions:**

<u>Ref</u>	<u>Condition</u>
1.57	Helicopter safed
13.3	ENCUC removed
11.254	F.S. 275 directional bellcrank removed

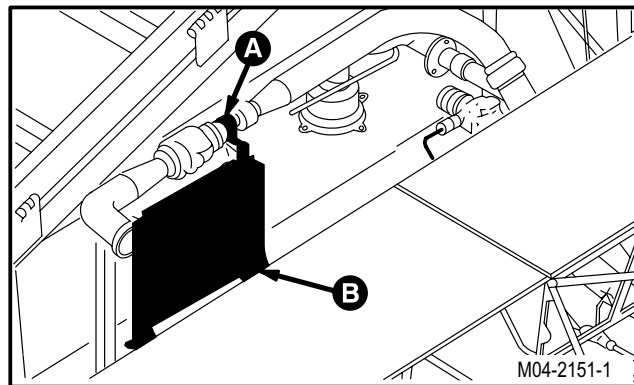

GO TO NEXT PAGE

**13.14. ENCU SUPPORT REMOVAL/INSTALLATION - continued**

13.14.3. Removal

a. **Remove clamp (1) from ENCU support (2).**

- (1) Remove two screws (3) and washers (4).
- (2) Remove clamp (1).

b. **Remove support (2) from deck (5).**

- (1) Remove three screws (6) and washers (7).
- (2) Remove sealing compound from four bolts (8) (para 1.47).
- (3) Remove six bolts (8) and washers (9) from support (2).
- (4) Remove two bolts (8) and washers (9) from jumper wires (10).
- (5) Remove support (2).

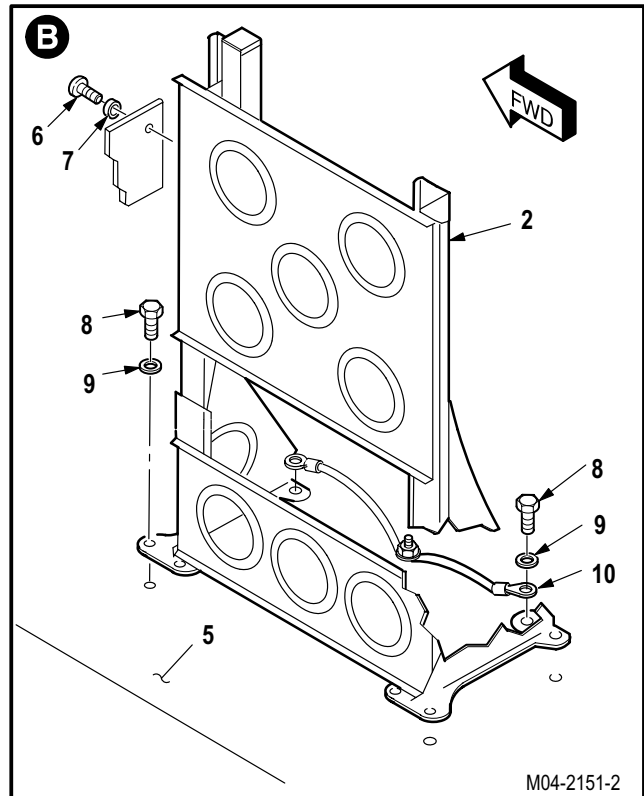
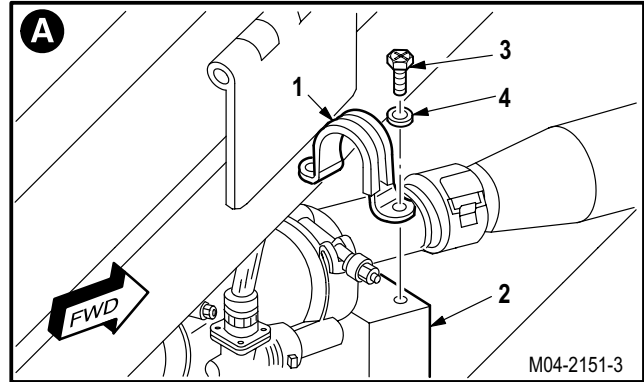

13.14.4. Cleaning

a. **Clean removed and attaching parts** (para 1.47).

13.14.5. Inspection

- a. **Check support nutplates for loose rivets and stripped or damaged threads** (para 13.1).
- b. **Check support and aft deck mounting area for hole elongation, cracks, and stripped or damaged threads** (para 13.1).
- c. **Check removed and attaching parts for corrosion** (para 1.49).

GO TO NEXT PAGE

## 13.14. ENCU SUPPORT REMOVAL/INSTALLATION - continued

### 13.14.6. Installation

- a. **Install support (2) on deck (5).** Torque eight bolts (8) to **80 INCH-POUNDS**.

- (1) Aline support (2) on deck (5).
- (2) Install six bolts (8) and washers (9) on support (2).
- (3) Install two bolts (8) through washers (9) and jumper wires (10).
- (4) Torque eight bolts (8) to **80 INCH-POUNDS**. Use torque wrench.

- (5) Install three screws (6) and washers (7).

- b. **Perform electrical bond check on support (2)** (TM 55-1500-323-24).

- (1) Bond shall be **1.0 OHM** or less. Use multimeter.



- c. **Apply sealing compound around edge of support (2), two outboard bolts (8), and on two bolts (8) with jumper wires (10).** Use sealing compound (item 175, App F).

- d. **Install clamp (1) on support (2).**

- (1) Install two screws (3) and washers (4).

- e. **Inspect (QA).**

- f. **Install F.S. 275 directional bellcrank** (para 11.254).

- g. **Install ENCU** (para 13.3).

- h. **Secure access doors T250L, T250R, T290L, T290R, and L325** (para 2.2).

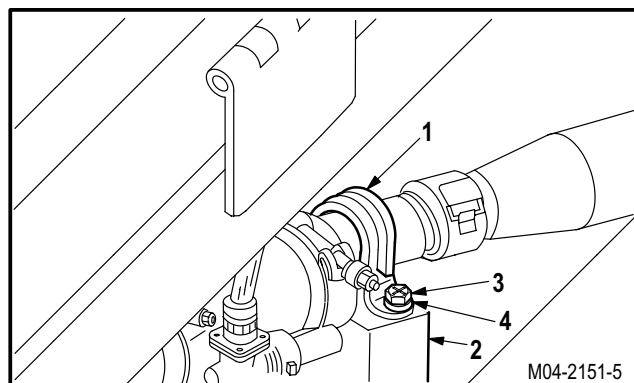
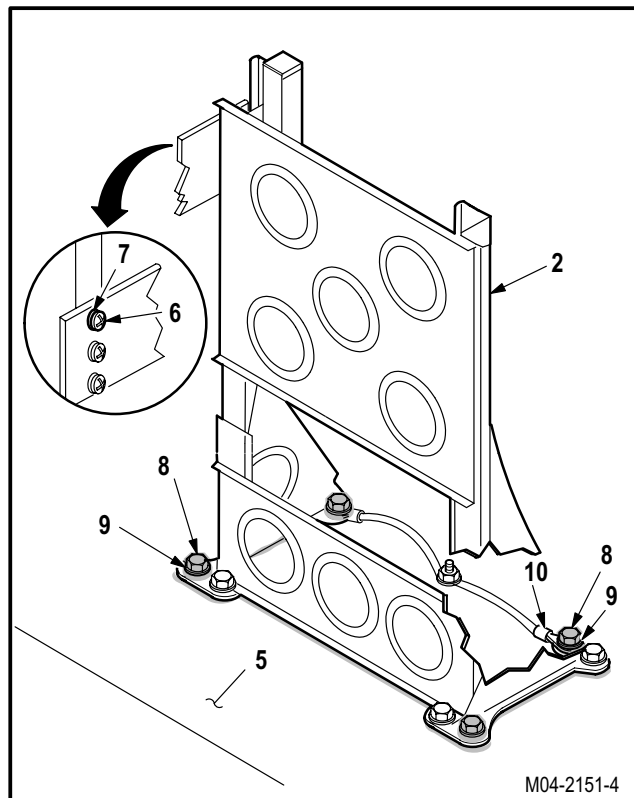

END OF TASK

## 13.15. ECS SHUTOFF VALVE REMOVAL/INSTALLATION

### 13.15.1. Description

This task covers: Removal. Cleaning. Inspection. Installation.

### 13.15.2. Initial Setup

#### Tools:

Aircraft mechanic's tool kit (item 376, App H)  
 Light duty laboratory apron (item 27, App H)  
 Industrial faceshield (item 129, App H)  
 Chemical protective gloves (item 154, App H)  
 10 - 50 inch-pound 1/4-inch drive click type torque wrench (item 434, App H)

#### References:

TM 1-1520-238-T  
 ■ TM 55-1500-323-24

#### Materials/Parts:

Packing (2)  
 Petrolatum (item 138, App F)

#### Equipment Conditions:

#### Personnel Required:

67R Attack Helicopter Repairer  
 67R3F Attack Helicopter Repairer/Technical Inspector

<u>Ref</u>	<u>Condition</u>
1.57	Helicopter safed
2.2	Access doors T250L, T250R, T290L, T290R, and L325 opened

### 13.15.3. Removal

- a. **Enter pilot station (para 1.56). Observe all safety precautions.**
- b. **On pilot aft circuit breaker panel, open ECS AFT FAN circuit breaker.**

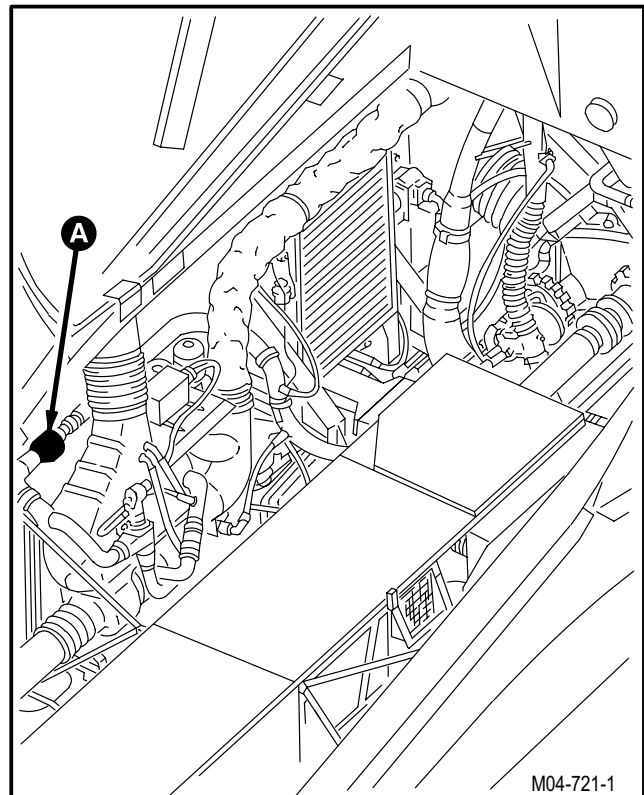

M04-721-1

GO TO NEXT PAGE

**13.15. ECS SHUTOFF VALVE REMOVAL/INSTALLATION - continued**

c. **Detach connector P286 (1) from receptacle (L38)J1 (2).**

d. **Remove shutoff valve (3) from air ducts (4) and (5).**

(1) Remove nut (6) from clamp (7).

(2) Remove clamp (7).

(3) Remove nut (8) from clamp (9).

(4) Remove clamp (9).

(5) Remove shutoff valve (3).

e. **Remove and discard two packings (10) from flanges of ducts (4) and (5).**

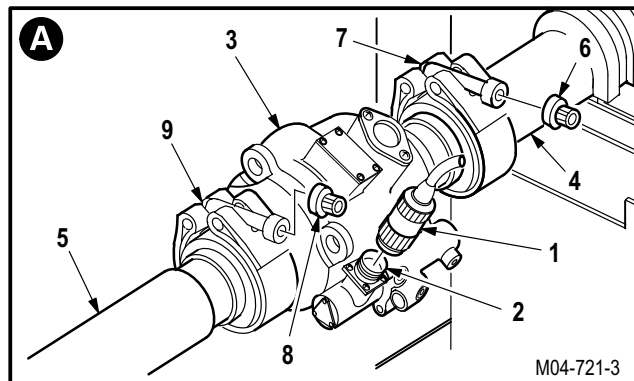

13.15.4. Cleaning

a. **Wipe removed and attaching parts with a clean rag.**

13.15.5. Inspection

a. **Check air ducts for cracks, nicks, or dents (para 13.1).**

b. **Check removed and attaching parts for corrosion (para 1.49).**

c. **Check shutoff valve for damage (para 13.1).**

d. **Check valve for loose or missing screws. None allowed.**

e. **Check valve for scored or distorted flanges. None allowed.**

f. **Check valve identification plate for deformation, legibility, and security.**

g. **Check connector for cracks, corrosion, and broken, bent, or damaged pins (TM 55-1500-323-24).**

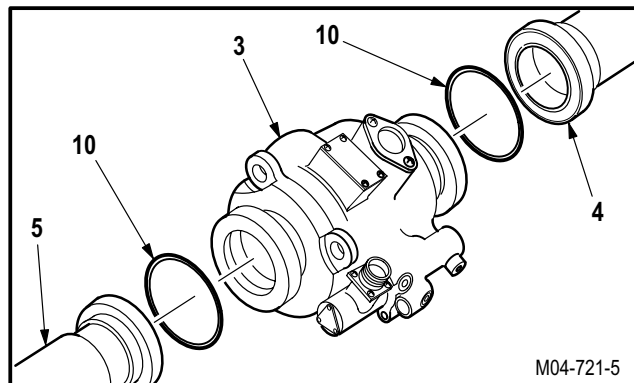

GO TO NEXT PAGE

**13.15. ECS SHUTOFF VALVE REMOVAL/INSTALLATION - continued**

13.15.6. Installation



a. **Install two new packings (10) in flanges of ducts (4) and (5).**

- (1) Lubricate packings (10). Use petrolatum (item 138, App F).
- (2) Install packings (10).

b. **Install shutoff valve (3) on ducts (4) and (5). Torque nuts (6) and (8) to 30 INCH-POUNDS.**

**NOTE**

Position shutoff valve so that sight window is visible and receptacle (L38)J1 is accessible.

- (1) Position shutoff valve (3) between ducts (4) and (5).
  - (2) Install clamp (9) on duct (5) and shutoff valve (3).
  - (3) Install nut (8). Torque nut (8) to **30 INCH-POUNDS**. Use torque wrench.
  - (4) Install clamp (7) on duct (4) and shutoff valve (3).
  - (5) Install nut (6). Torque nut (6) to **30 INCH-POUNDS**. Use torque wrench.
- c. **Attach connector P286 (1) to receptacle (L38)J1 (2).**
- d. **Inspect (QA).**
- e. **Perform ECS maintenance operational check (TM 1-1520-238-T).**
- f. **Secure access doors T250L, T250R, T290L, T290R, and L325 (para 2.2).**

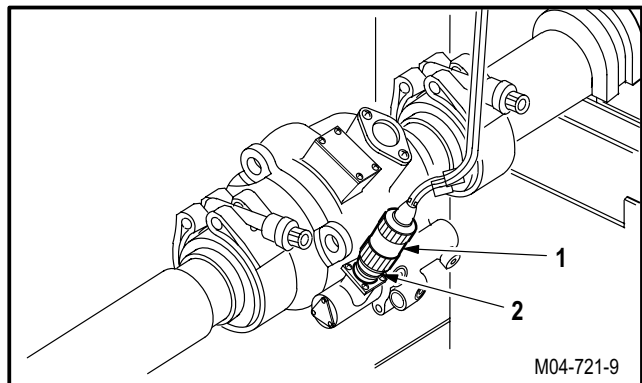
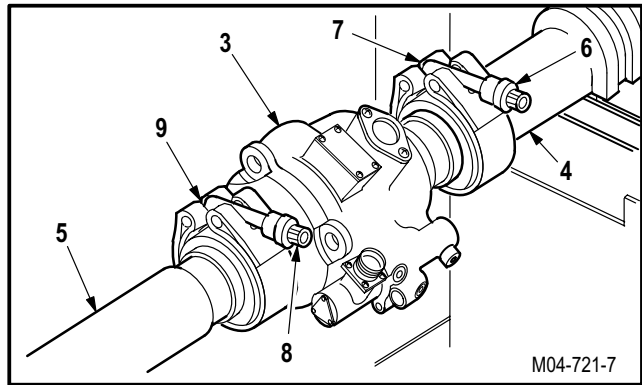
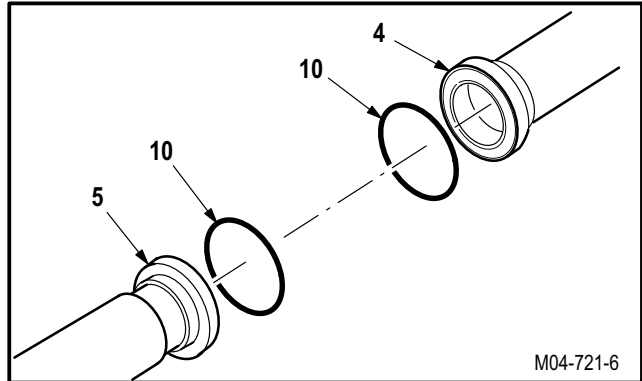

END OF TASK





**13.17. AIR DUCT NO. 1 REMOVAL/INSTALLATION**

13.17.1. Description

This task covers: Removal. Cleaning. Inspection. Installation.

13.17.2. Initial Setup

**Tools:**

Aircraft mechanic's tool kit (item 376, App H)

**Materials/Parts:**

Tape (item 200, App F)

**Personnel Required:**

67R Attack Helicopter Repairer  
 67R3F Attack Helicopter Repairer/Technical Inspector

**References:**

TM 1-1520-238-T

**Equipment Conditions:**

<u>Ref</u>	<u>Condition</u>
1.57	Helicopter safed
2.2	Access doors T250L, T250R, T290L, T290R, and L325 opened
13.11	ENCU temperature control sensor (if required)

**NOTE**

If replacing duct, remove ENCU temperature control sensor.

13.17.3. Removal

- a. **Enter pilot station** (para 1.56). **Observe all safety precautions.**
- b. **On pilot aft circuit breaker panel, open ECS CAB circuit breaker.**

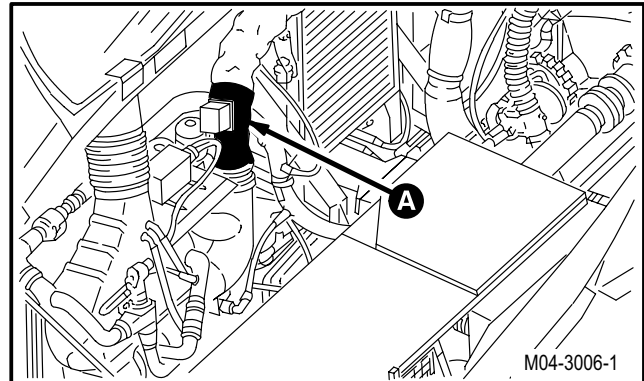

GO TO NEXT PAGE

---

**13.17. AIR DUCT NO. 1 REMOVAL/INSTALLATION - continued**

---

c. **Detach connector P285 (1) from temperature control sensor receptacle (A43)J1 (2).**

d. **Remove cuff (3) from air duct No. 1 (4) and air duct (5).**

(1) Remove tape (6) and separate cuff (3) velcro strips.

(2) Remove cuff (3).

e. **Remove duct (4) from duct (5) and ENCU (7).**

(1) Loosen four clamps (8) from two sleeves (9).

(2) Remove clamps (8) and sleeves (9).

(3) Remove duct (4).

13.17.4. Cleaning

a. **Wipe removed and attaching parts with a clean rag.**

13.17.5. Inspection

a. **Check ends of ducts, clamps, and brackets for excessive wear, cracks, or breaks** (para 13.1).

b. **Check sleeves, cuffs, and insulation on ducts for rips or tears** (para 13.1).

c. **Check rubber seals at both ends of ducts for chafing, cuts, or fraying** (para 13.1).

d. **Check removed and attaching parts for corrosion** (para 1.49).

e. **If required, check duct for loose, missing, or damaged nutplates** (para 13.1).

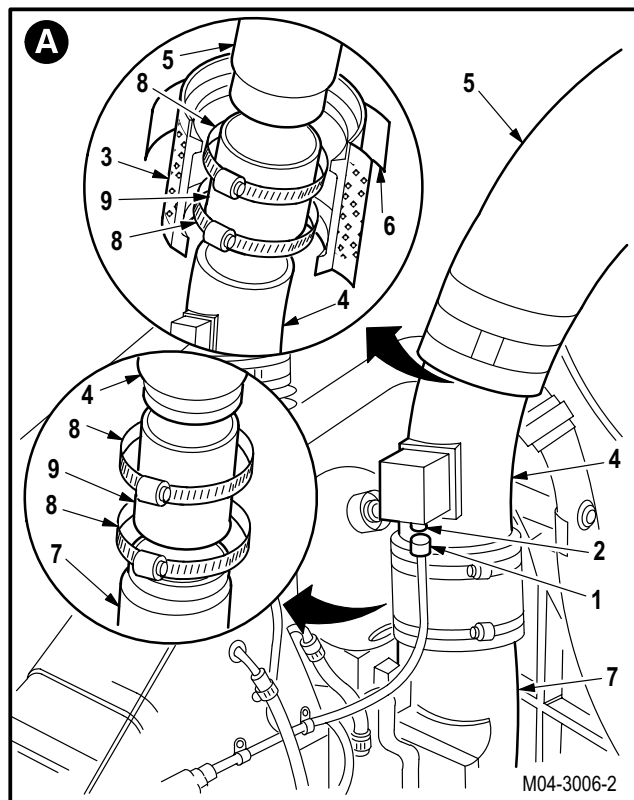

GO TO NEXT PAGE

**13.17. AIR DUCT NO. 1 REMOVAL/INSTALLATION - continued**

13.17.6. Installation

**a. Install duct (4) on duct (5) and ENCU (7).**

- (1) Install two clamps (8) and sleeve (9) on ENCU (7).
- (2) Install two clamps (8) and sleeve (9) on duct (4).
- (3) Position duct (4) between duct (5) and ENCU (7).
- (4) Center two sleeves (9) over duct (4), duct (5), and ENCU (7).
- (5) Position clamps (8) over sleeves (9).
- (6) Tighten clamps (8).

**b. Install cuff (3) on ducts (4) and (5).**

- (1) Position cuff (3) over ducts (4) and (5).
- (2) Secure cuff (3) velcro strips together.
- (3) Install tape (6) on cuff (3). Use tape (item 200, App F).

**c. Attach connector P285 (1) to receptacle (A43)J1 (2).**

**d. Inspect (QA).**

**e. Install temperature control sensor (if removed) (para 13.11).**

**f. Perform ECS maintenance operational check (TM 1-1520-238-T).**

**g. Secure access doors T250L, T250R, T290L, T290R, and L325 (para 2.2).**

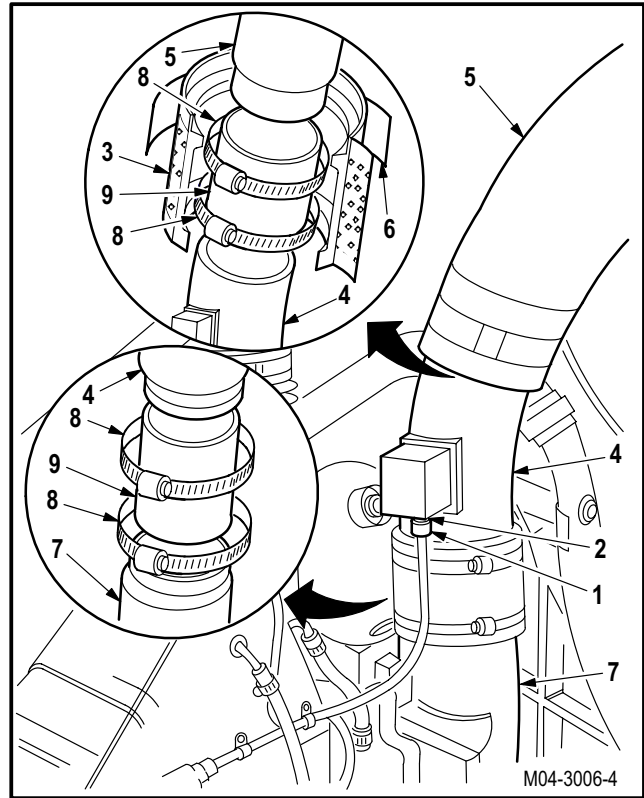

END OF TASK

---

## 13.18. AIR DUCT NO. 2 REMOVAL/INSTALLATION

---

### 13.18.1. Description

This task covers: Removal. Cleaning. Inspection. Installation.

---

### 13.18.2. Initial Setup

#### Tools:

Aircraft mechanic's tool kit (item 376, App H)

#### Materials/Parts:

Tape (item 200, App F)

#### Personnel Required:

67R Attack Helicopter Repairer  
 67R3F Attack Helicopter Repairer/Technical  
 Inspector

#### References:

TM 1-1520-238-T

#### Equipment Conditions:

<u>Ref</u>	<u>Condition</u>
1.57	Helicopter safed
2.2	Access doors T250L, T250R, T290L, T290R, and L325 opened

### 13.18.3. Removal

- a. **Enter pilot station** (para 1.56). **Observe all safety precautions.**
- b. **On pilot aft circuit breaker panel, open ECS CAB circuit breaker.**

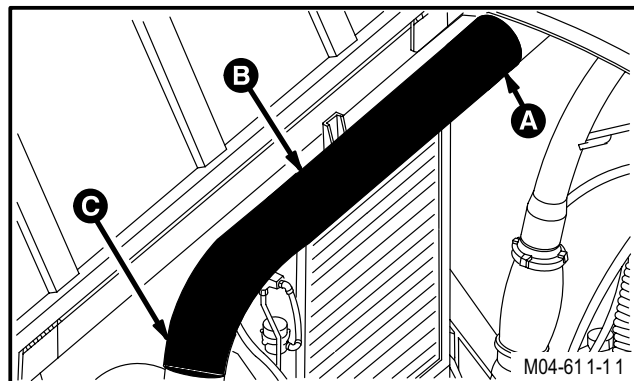

GO TO NEXT PAGE

**13.18. AIR DUCT NO. 2 REMOVAL/INSTALLATION - continued**

c. **Remove defog hose (1) and clamp (2) from bracket (3).**

- (1) Remove screw (4), washer (5), and nut (6).
- (2) Remove hose (1) and clamp (2).

d. **Remove three cuffs (7) from air duct No. 2 (8) and air ducts (9) and (10).**

- (1) Remove tape (11) and separate cuff (7) velcro strips.
- (2) Remove cuffs (7).

e. **Remove duct (8) from ducts (9) and (10).**

- (1) Loosen five clamps (12) from two sleeves (13) and brackets (3), (14), and (15).
- (2) Remove bracket (3), clamps (12), and sleeves (13).
- (3) Remove duct (8).

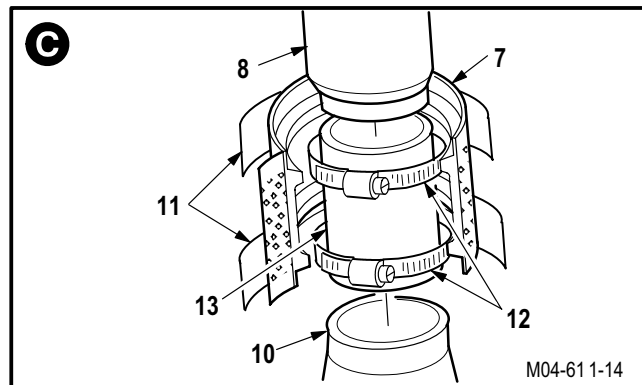
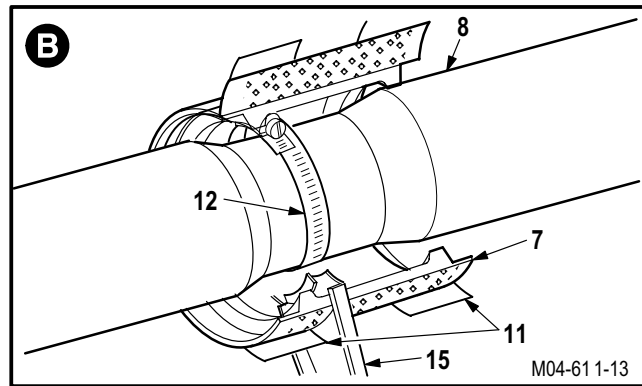
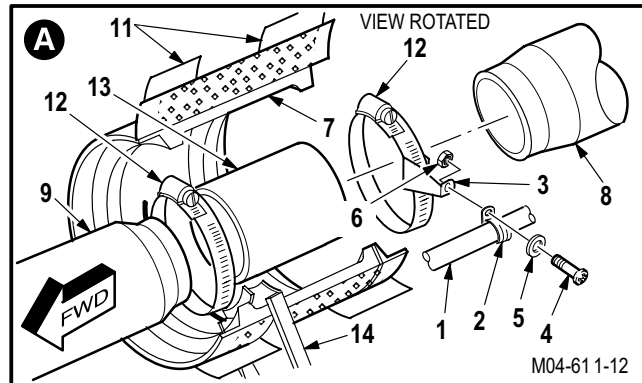

13.18.4. Cleaning

a. **Wipe removed and attaching parts with a clean rag.**

13.18.5. Inspection

- a. **Check ends of ducts, clamps, and brackets for excessive wear, cracks, or breaks** (para 13.1).
- b. **Check sleeves, cuffs, and insulation on ducts for rips or tears** (para 13.1).
- c. **Check rubber seals at both ends of ducts for chafing, cuts, or fraying** (para 13.1).
- d. **Check removed and attaching parts for corrosion** (para 1.49).

GO TO NEXT PAGE

**13.18. AIR DUCT NO. 2 REMOVAL/INSTALLATION - continued**

13.18.6. Installation

**a. Install duct (8) on ducts (9) and (10).**

- (1) Install five clamps (12) and two sleeves (13) on duct (8).
- (2) Position duct (8) between ducts (9) and (10).
- (3) Center two sleeves (13) over ducts (8), (9), and (10).
- (4) Position clamps (12) over sleeves (13) and brackets (3), (14), and (15).
- (5) Tighten clamps (12).

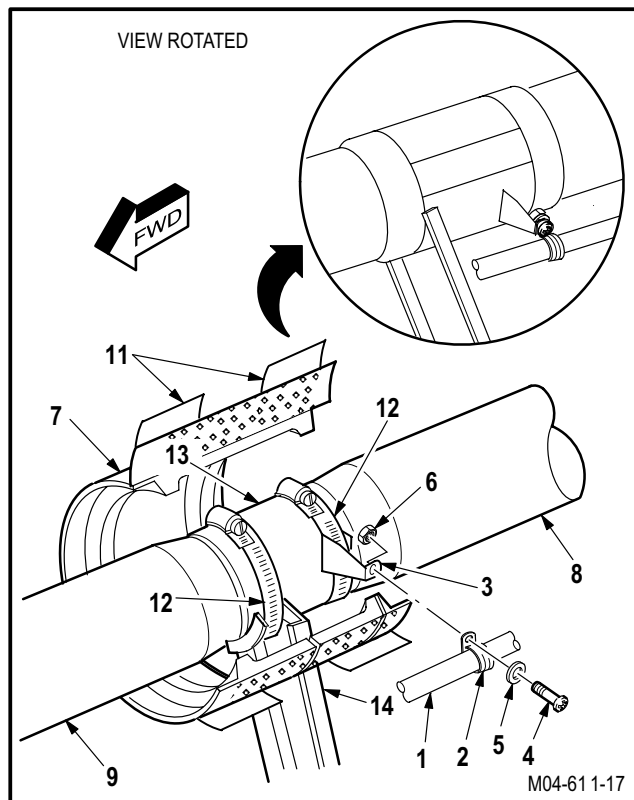

**b. Install three cuffs (7) on ducts (8), (9), and (10).**

- (1) Position cuffs (7) over ducts (8), (9), and (10).
- (2) Secure cuff (7) velcro strips together.
- (3) Install tape (11) on cuffs (7). Use tape (item 200, App F).

**c. Install hose (1) and clamp (2) on bracket (3).**

- (1) Position clamp (2) on bracket (3).
- (2) Install screw (4) through washer (5), clamp (2), bracket (3), and nut (6).

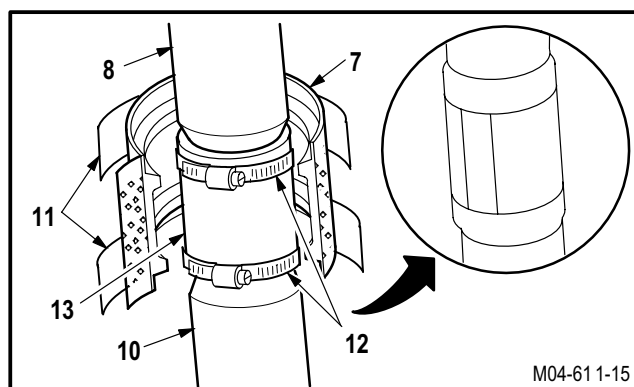

**d. Inspect (QA).**

**e. Perform ECS maintenance operational check (TM 1-1520-238-T).**

**f. Secure access doors T250L, T250R, T290L, T290R, and L325 (para 2.2).**

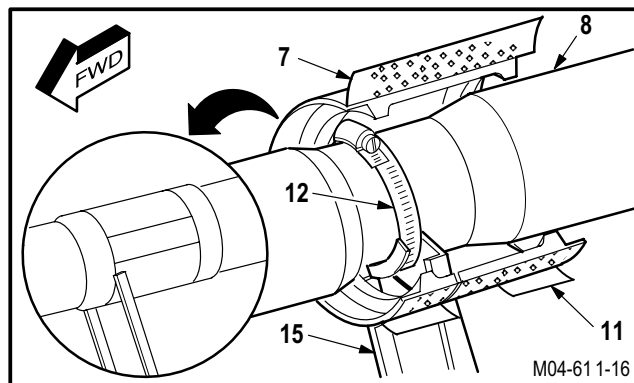

END OF TASK

**13.19. AIR DUCT NO. 3 REMOVAL/INSTALLATION**

13.19.1. Description

This task covers: Removal. Cleaning. Inspection. Installation.

13.19.2. Initial Setup

**Tools:**

Aircraft mechanic's tool kit (item 376, App H)

**References:**

TM 1-1520-238-T

**Materials/Parts:**

Tape (item 200, App F)

**Equipment Conditions:**

<u>Ref</u>	<u>Condition</u>
1.57	Helicopter safed
2.2	Access doors T250L, T250R, T290L, T290R, and L325 opened; panel L200 removed

**Personnel Required:**

67R Attack Helicopter Repairer  
 67R3F Attack Helicopter Repairer/Technical Inspector

13.19.3. Removal

- a. **Enter pilot station** (para 1.56). **Observe all safety precautions.**
- b. **On pilot aft circuit breaker panel, open ECS CAB circuit breaker.**

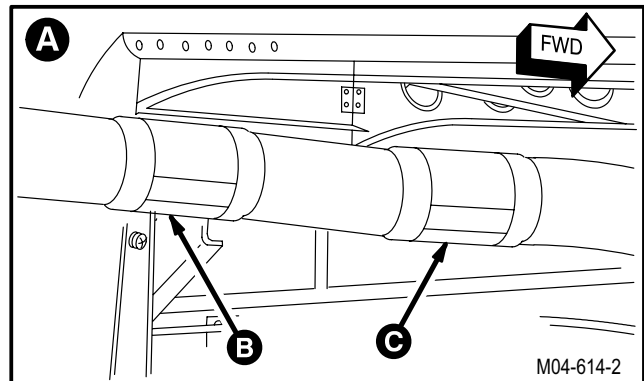
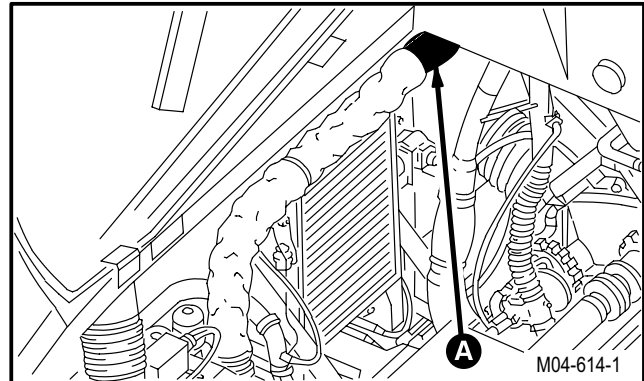

GO TO NEXT PAGE



**13.19. AIR DUCT NO. 3 REMOVAL/INSTALLATION - continued**

c. **Remove defog hose (1) and clamp (2) from bracket (3).**

(1) Remove screw (4), washer (5), and nut (6).

(2) Remove hose (1) and clamp (2).

d. **Remove two cuffs (7) from air duct No. 3 (8) and air ducts (9) and (10).**

(1) Remove tape (11) and separate cuff (7) velcro strips.

(2) Remove cuffs (7).

e. **Remove duct (8) from ducts (9) and (10).**

(1) Loosen four clamps (12) from two sleeves (13) and brackets (3), (14), and (15).

(2) Remove bracket (3), clamps (12), and sleeves (13).

(3) Remove duct (8).

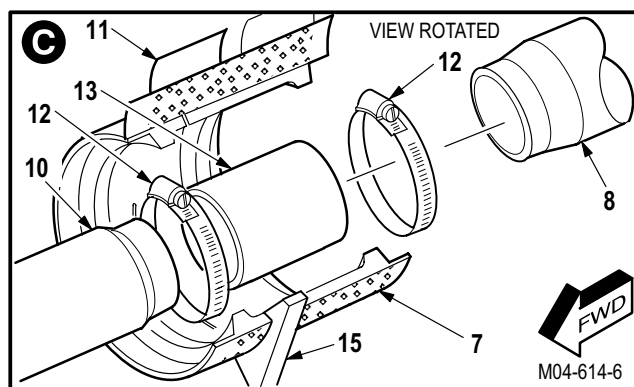
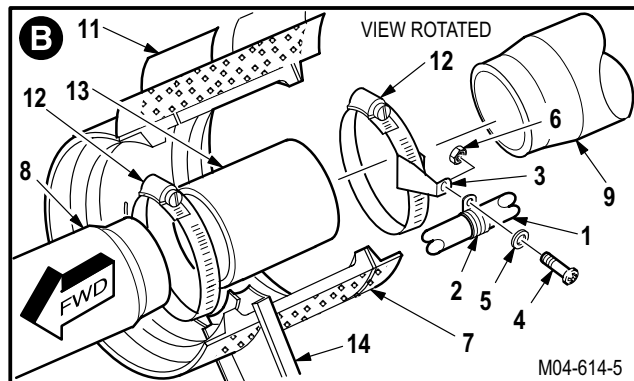

13.19.4. Cleaning

a. **Wipe removed and attaching parts with a clean rag.**

13.19.5. Inspection

a. **Check ends of ducts, clamps, and brackets for excessive wear, cracks, or breaks** (para 13.1).

b. **Check sleeves, cuffs, and insulation on ducts for rips or tears** (para 13.1).

c. **Check rubber seals at both ends of ducts for chafing, cuts, or fraying** (para 13.1).

d. **Check removed and attaching parts for corrosion** (para 1.49).

GO TO NEXT PAGE

**13.19. AIR DUCT NO. 3 REMOVAL/INSTALLATION - continued**

13.19.6. Installation

**a. Install duct (8) on ducts (9) and (10).**

- (1) Install four clamps (12) and two sleeves (13) on duct (8).
- (2) Position duct (8) between ducts (9) and (10).
- (3) Center two sleeves (13) over ducts (8), (9), and (10).
- (4) Position clamps (12) over sleeves (13) and brackets (3), (14), and (15).
- (5) Tighten clamps (12).

**b. Install two cuffs (7) on ducts (8), (9), and (10).**

- (1) Position cuffs (7) over ducts (8), (9), and (10).
- (2) Secure cuff (7) velcro strips together.
- (3) Install tape (11) on cuffs (7). Use tape (item 200, App F).

**c. Install hose (1) and clamp (2) on bracket (3).**

- (1) Position clamp (2) on bracket (3).
- (2) Install screw (4) through washer (5), clamp (2), bracket (3), and nut (6).

**d. Inspect (QA).**

**e. Perform ECS maintenance operational check (TM 1-1520-238-T).**

**f. Secure access doors T250L, T250R, T290L, T290R, and L325; install panel L200 (para 2.2).**

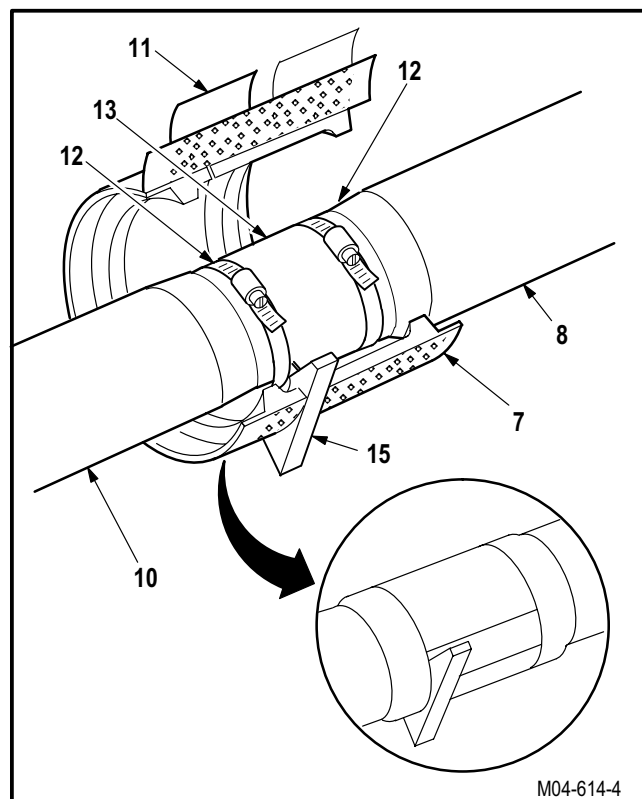
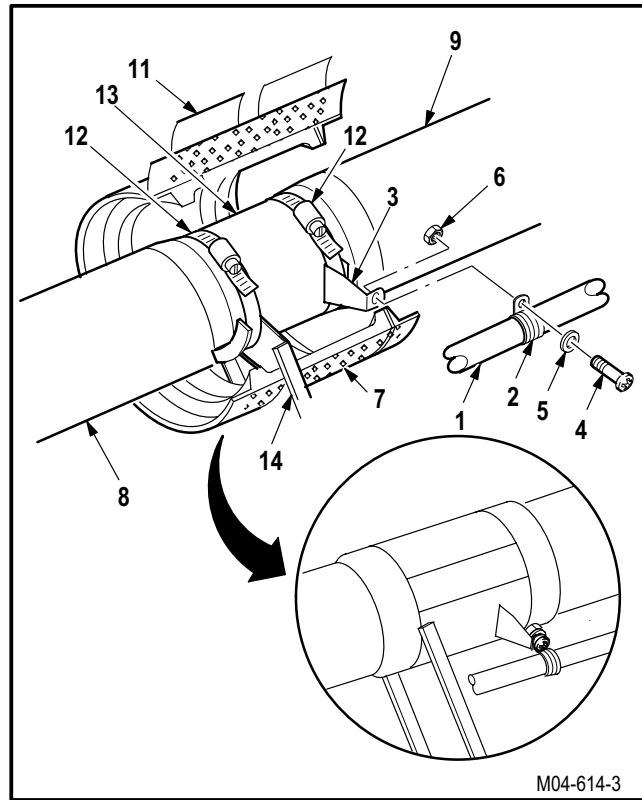

END OF TASK

---

## 13.20. AIR DUCT NO. 4 REMOVAL/INSTALLATION

---

### 13.20.1. Description

This task covers: Removal. Cleaning. Inspection. Installation.

---

### 13.20.2. Initial Setup

#### Tools:

Aircraft mechanic's tool kit (item 376, App H)

#### Materials/Parts:

Tape (item 200, App F)

#### Personnel Required:

67R Attack Helicopter Repairer  
 67R3F Attack Helicopter Repairer/Technical  
 Inspector

#### References:

TM 1-1520-238-T

#### Equipment Conditions:

<u>Ref</u>	<u>Condition</u>
1.57	Helicopter safed
2.2	Access panel L200 removed

### 13.20.3. Removal

- a. **Enter pilot station** (para 1.56). **Observe all safety precautions.**
- b. **On pilot aft circuit breaker panel, open ECS CAB circuit breaker.**

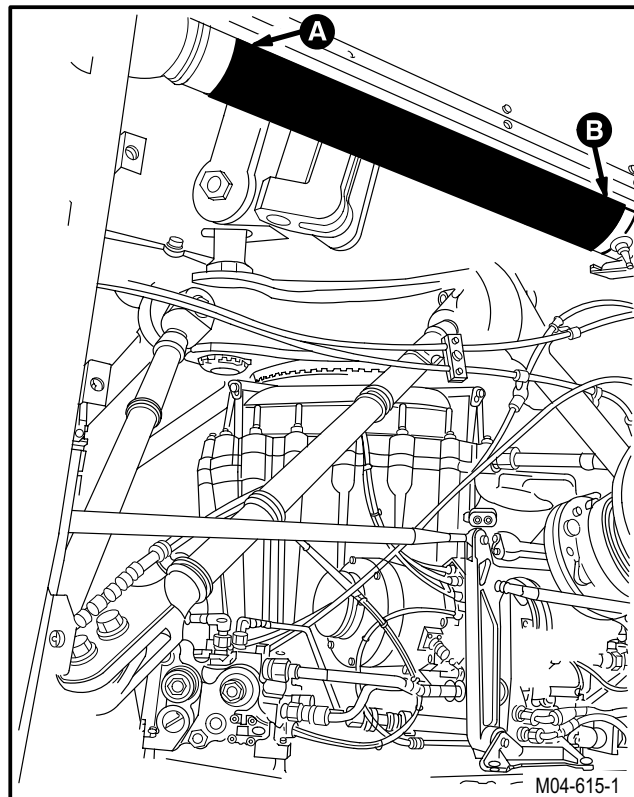

GO TO NEXT PAGE

**13.20. AIR DUCT NO. 4 REMOVAL/INSTALLATION - continued**

**c. Remove two cuffs (1) from air duct No. 4 (2) and air ducts (3) and (4).**

- (1) Remove tape (5) and separate cuff (1) velcro strips.
- (2) Remove cuffs (1).

**d. Remove duct (2) from ducts (3) and (4).**

- (1) Loosen four clamps (6) from two sleeves (7) and brackets (8) and (9).
- (2) Remove clamps (6) and sleeves (7).
- (3) Remove duct (2).

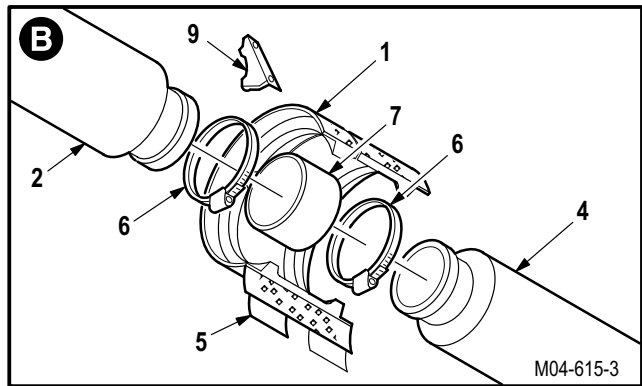
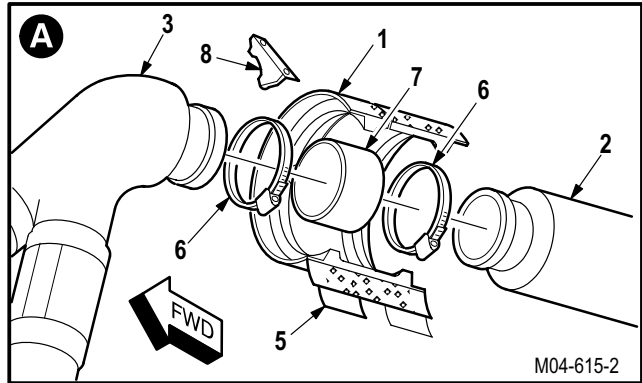

**13.20.4. Cleaning**

**a. Wipe removed and attaching parts with a clean rag.**

**13.20.5. Inspection**

- a. Check ends of ducts, clamps, and brackets for excessive wear, cracks, or breaks (para 13.1).
- b. Check sleeves, cuffs, and insulation on ducts for rips or tears (para 13.1).
- c. Check rubber seals at both ends of ducts for chafing, cuts, or fraying (para 13.1).
- d. Check removed and attaching parts for corrosion (para 1.49).

GO TO NEXT PAGE

---

**13.20. AIR DUCT NO. 4 REMOVAL/INSTALLATION - continued**



---

13.20.6. Installation**a. Install duct (2) on ducts (3) and (4).**

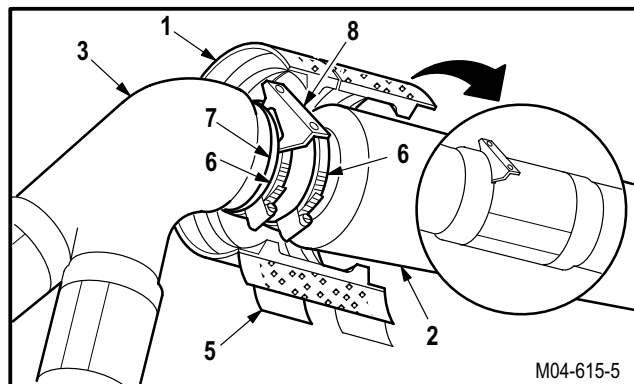
- (1) Install four clamps (6) and two sleeves (7) on duct (2).
- (2) Position duct (2) between ducts (3) and (4).
- (3) Center two sleeves (7) over ducts (2), (3), and (4).
- (4) Position clamps (6) over sleeves (7) and brackets (8) and (9).
- (5) Tighten clamps (6).

**b. Install two cuffs (1) on ducts (2), (3), and (4).**

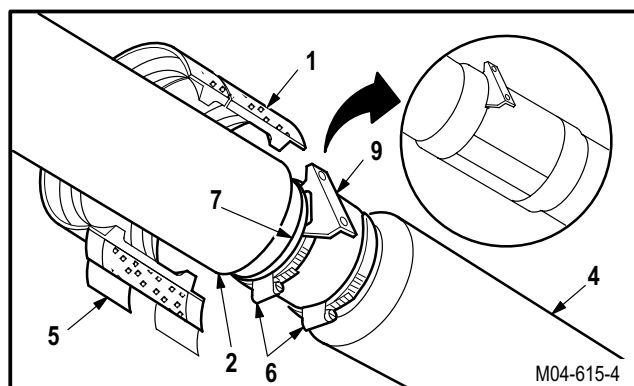
- (1) Position cuffs (1) over ducts (2), (3), and (4).
- (2) Secure cuff (1) velcro strips together.
- (3) Install tape (5) on cuffs (1). Use tape (item 200, App F).

**c. Inspect (QA).****d. Perform ECS maintenance operational check (TM 1-1520-238-T).****e. Install access panel L200 (para 2.2).**

END OF TASK

---

## 13.21. AIR DUCT NO. 5 REMOVAL/INSTALLATION

---

### 13.21.1. Description

This task covers: Removal. Cleaning. Inspection. Installation.

---

### 13.21.2. Initial Setup

#### Tools:

Aircraft mechanic's tool kit (item 376, App H)

#### Materials/Parts:

Tape (item 200, App F)

#### Personnel Required:

67R Attack Helicopter Repairer  
67R3F Attack Helicopter Repairer/Technical  
Inspector

#### References:

TM 1-1520-238-T

#### Equipment Conditions:

<u>Ref</u>	<u>Condition</u>
1.57	Helicopter safed
2.2	Access panel L200 removed

### 13.21.3. Removal

- a. **Enter pilot station** (para 1.56). **Observe all safety precautions.**
- b. **On pilot aft circuit breaker panel, open ECS CAB circuit breaker.**

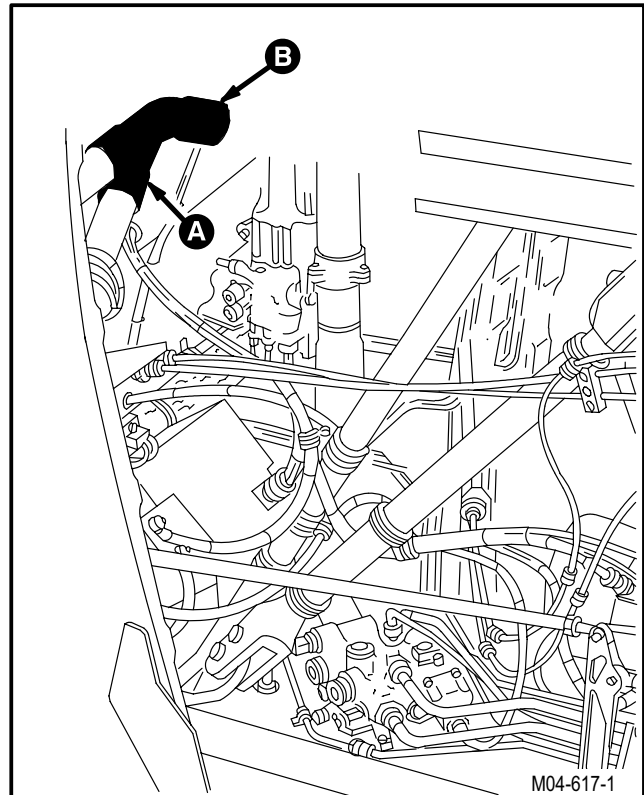

GO TO NEXT PAGE

**13.21. AIR DUCT NO. 5 REMOVAL/INSTALLATION - continued**

c. **Remove three cuffs (1) from air duct No. 5 (2) and air ducts (3), (4), and (5).**

(1) Remove tape (6) and separate cuffs (1) velcro strips.

(2) Remove cuffs (1).

d. **Remove duct (2) from ducts (3), (4), and (5).**

(1) Loosen six clamps (7) from three sleeves (8) and bracket (9).

(2) Remove clamps (7) and sleeves (8).

(3) Remove duct (2).

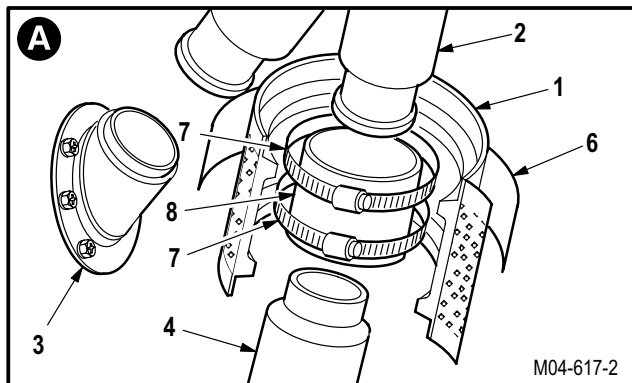

M04-617-2

13.21.4. Cleaning

a. **Wipe removed and attaching parts with a clean rag.**

13.21.5. Inspection

a. **Check ends of ducts, clamps, and brackets for excessive wear, cracks, or breaks** (para 13.1).

b. **Check sleeves, cuffs, and insulation on ducts for rips or tears** (para 13.1).

c. **Check rubber seals at both ends of ducts for chafing, cuts, or fraying** (para 13.1).

d. **Check removed and attaching parts for corrosion** (para 1.49).

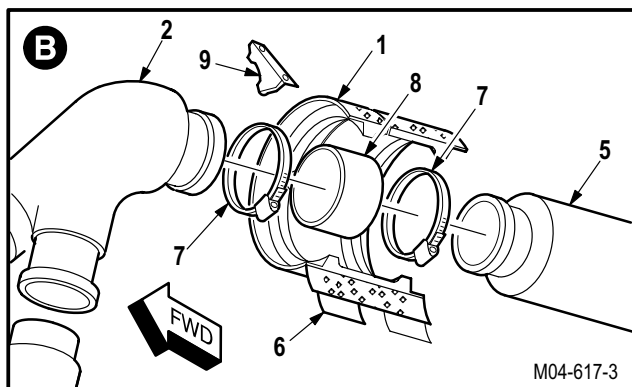

M04-617-3

GO TO NEXT PAGE

**13.21. AIR DUCT NO. 5 REMOVAL/INSTALLATION - continued**

13.21.6. Installation

**a. Install duct (2) on ducts (3), (4), and (5).**

- (1) Install four clamps (7) and two sleeves (8) on ducts (3) and (4).
- (2) Install two clamps (7) and sleeve (8) on duct (5).
- (3) Position duct (2) between ducts (3), (4), and (5).
- (4) Center three sleeves (8) over ducts (2), (3), (4), and (5).
- (5) Position six clamps (7) over sleeves (8) and bracket (9).
- (6) Tighten clamps (7).

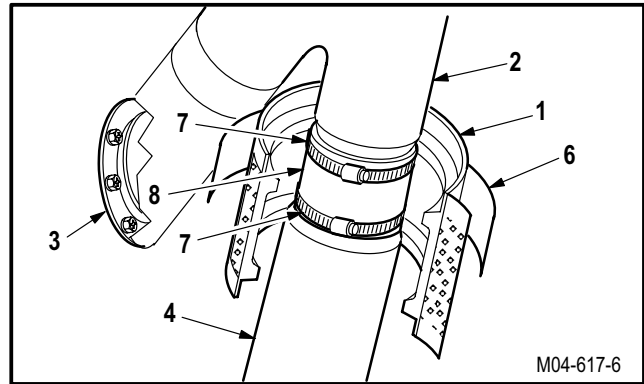

**b. Install three cuffs (1) on ducts (2), (3), (4), and (5).**

- (1) Position three cuffs (1) over ducts (2), (3), (4), and (5).
- (2) Secure cuffs (1) velcro strips together.
- (3) Install tape (6) on cuffs (1). Use tape (item 200, App F).

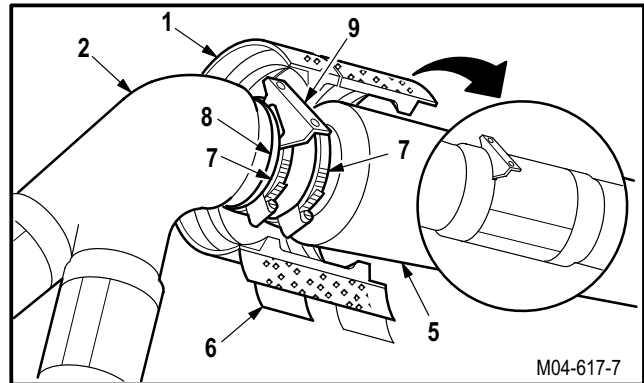

**c. Inspect (QA).**

**d. Perform ECS maintenance operational check (TM 1-1520-238-T).**

**e. Install access panel L200 (para 2.2).**

END OF TASK



---

## 13.22. AIR DUCT NO. 6 REMOVAL/INSTALLATION

---

### 13.22.1. Description

This task covers: Removal. Cleaning. Inspection. Installation.

---

### 13.22.2. Initial Setup

#### Tools:

Aircraft mechanic's tool kit (item 376, App H)

#### Materials/Parts:

Tape (item 200, App F)

#### Personnel Required:

67R Attack Helicopter Repairer  
 67R3F Attack Helicopter Repairer/Technical  
 Inspector

#### References:

TM 1-1520-238-T

#### Equipment Conditions:

<u>Ref</u>	<u>Condition</u>
1.57	Helicopter safed
2.2	Access panel L200 removed
9.30	No. 1 transformer-rectifier removed

### 13.22.3. Removal

- a. **Enter pilot station** (para 1.56). **Observe all safety precautions.**
- b. **On pilot aft circuit breaker panel, open ECS CAB circuit breaker.**

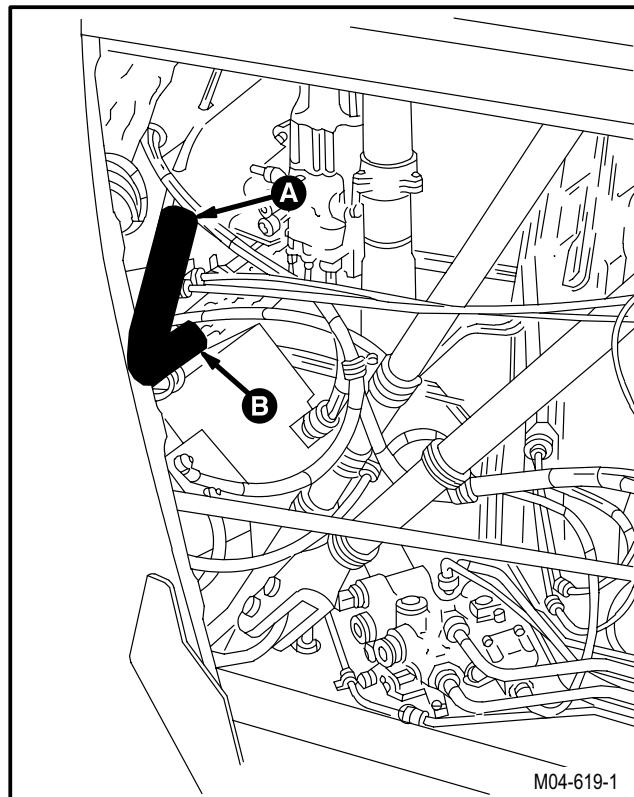

GO TO NEXT PAGE

**13.22. AIR DUCT NO. 6 REMOVAL/INSTALLATION - continued**

**c. Remove two cuffs (1) from air duct No. 6 (2) and air ducts (3) and (4).**

- (1) Remove tape (5) and separate cuff (1) velcro strips.
- (2) Remove cuffs (1).

**d. Remove duct (2) from ducts (3) and (4).**

- (1) Loosen four clamps (6) from two sleeves (7) and bracket (8).
- (2) Remove clamps (6) and sleeves (7).
- (3) Remove duct (2).

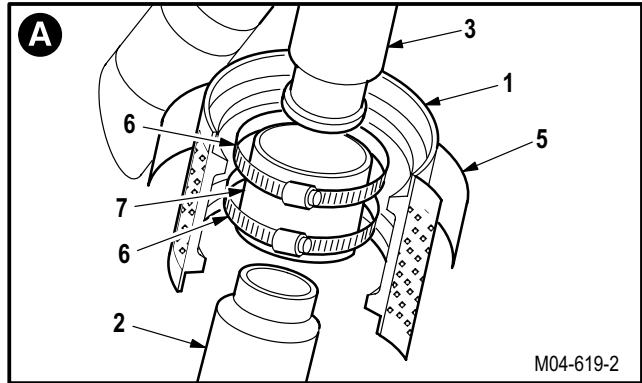

**13.22.4. Cleaning**

**a. Wipe removed and attaching parts with a clean rag.**

**13.22.5. Inspection**

- a. **Check ends of ducts, clamps, and brackets for evidence of excessive wear, cracks, or breaks** (para 13.1).
- b. **Check sleeves, cuffs, and insulation on ducts for rips or tears** (para 13.1).
- c. **Check rubber seals at both ends of ducts for chafing, cuts, or fraying** (para 13.1).
- d. **Check removed and attaching parts for corrosion** (para 1.49).

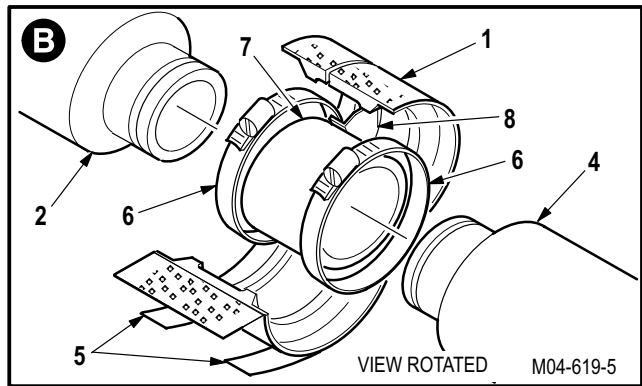

GO TO NEXT PAGE

---

**13.22. AIR DUCT NO. 6 REMOVAL/INSTALLATION - continued**



---

13.22.6. Installation**a. Install duct (2) on ducts (3) and (4).**

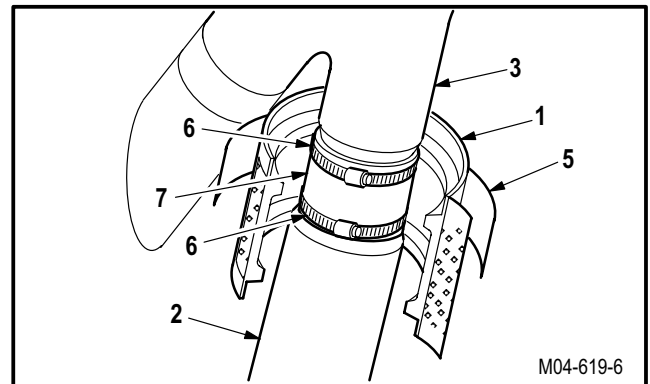
- (1) Install four clamps (6) and two sleeves (7) on duct (2).
- (2) Position duct (2) between ducts (3) and (4).
- (3) Center two sleeves (7) over ducts (2), (3), and (4).
- (4) Position clamps (6) over sleeves (7) and bracket (8).
- (5) Tighten clamps (6).

**b. Install two cuffs (1) on ducts (2), (3), and (4).**

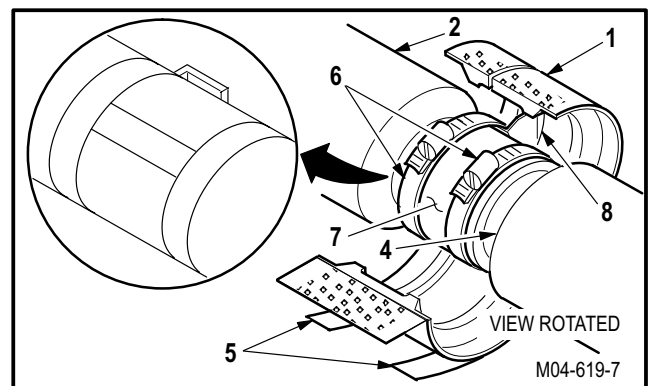
- (1) Position cuffs (1) over ducts (2), (3), and (4).
- (2) Secure cuff (1) velcro strips together.
- (3) Install tape (5) on cuffs (1). Use tape (item 200, App F).

**c. Inspect (QA).****d. Install No. 1 transformer-rectifier (para 9.30).****e. Perform ECS maintenance operational check (TM 1-1520-238-T).****f. Install access panel L200 (para 2.2).**

END OF TASK

---

### 13.23. AIR DUCT NO. 7 REMOVAL/INSTALLATION

---

#### 13.23.1. Description

This task covers: Removal. Cleaning. Inspection. Installation.

---

#### 13.23.2. Initial Setup

##### **Tools:**

Aircraft mechanic's tool kit (item 376, App H)

##### **Materials/Parts:**

Tape (item 200, App F)

##### **Personnel Required:**

67R Attack Helicopter Repairer  
67R3F Attack Helicopter Repairer/Technical Inspector

##### **References:**

TM 1-1520-238-T

##### **Equipment Conditions:**

<u>Ref</u>	<u>Condition</u>
1.57	Helicopter safed
2.2	Access panels L200 and R200 removed
9.32	No. 2 transformer-rectifier removed

---

#### 13.23.3. Removal

- a. **Enter pilot station** (para 1.56). **Observe all safety precautions.**
- b. **On pilot aft circuit breaker panel, open ECS CAB circuit breaker.**

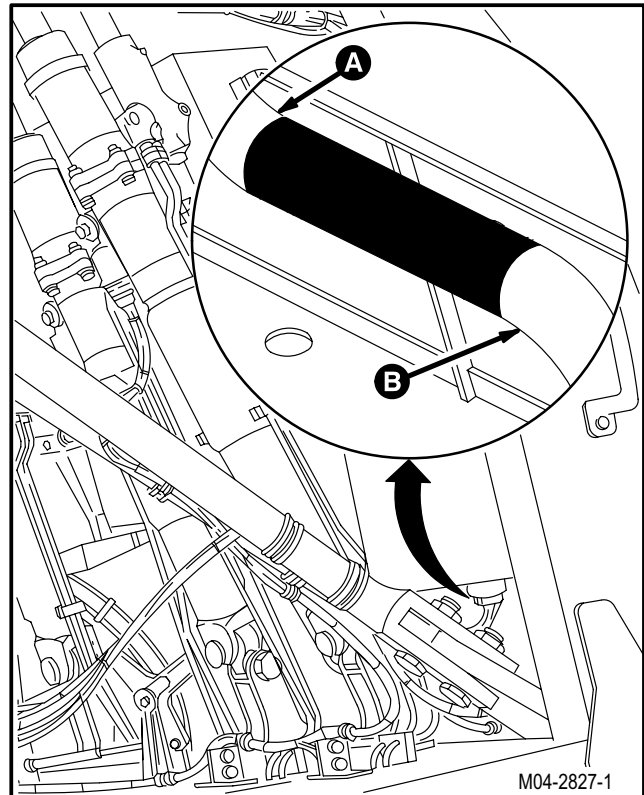

GO TO NEXT PAGE

**13.23. AIR DUCT NO. 7 REMOVAL/INSTALLATION - continued**

**c. Remove two cuffs (1) from air duct No. 7 (2) and air ducts (3) and (4).**

- (1) Remove tape (5) and separate cuff (1) velcro strips.
- (2) Remove cuffs (1).

**d. Remove duct (2) from ducts (3) and (4).**

- (1) Loosen four clamps (6) from two sleeves (7) and two brackets (8).
- (2) Remove clamps (6) and sleeves (7).
- (3) Remove duct (2).

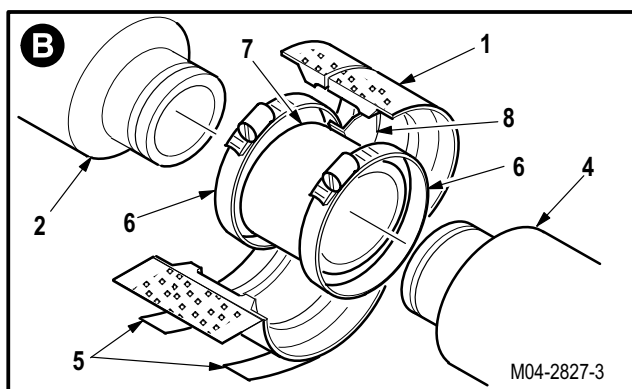
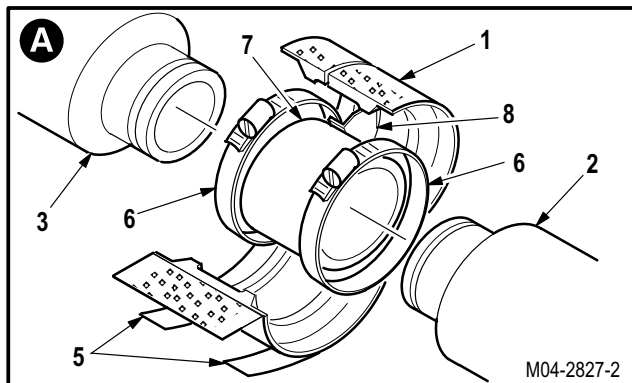

**13.23.4. Cleaning**

**a. Wipe removed and attaching parts with a clean rag.**

**13.23.5. Inspection**

- a. Check ends of ducts, clamps, and brackets for excessive wear, cracks, or breaks (para 13.1).
- b. Check sleeves, cuffs, and insulation on ducts for rips or tears (para 13.1).
- c. Check rubber seals at both ends of ducts for chafing, cuts, or fraying (para 13.1).
- d. Check removed and attaching parts for corrosion (para 1.49).

GO TO NEXT PAGE

**13.23. AIR DUCT NO. 7 REMOVAL/INSTALLATION - continued**

13.23.6. Installation

**a. Install duct (2) on ducts (3) and (4).**

- (1) Install four clamps (6) and two sleeves (7) on duct (2).
- (2) Position duct (2) between ducts (3) and (4).
- (3) Center two sleeves (7) over ducts (2), (3), and (4).
- (4) Position clamps (6) over sleeves (7) and brackets (8).
- (5) Tighten clamps (6).

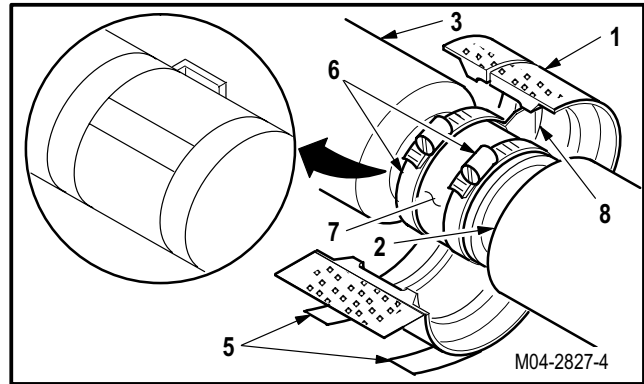

**b. Install two cuffs (1) on ducts (2), (3), and (4).**

- (1) Position cuffs (1) over ducts (2), (3), and (4).
- (2) Secure cuff (1) velcro strips together.
- (3) Install tape (5) on cuffs (1). Use tape (item 200, App F).

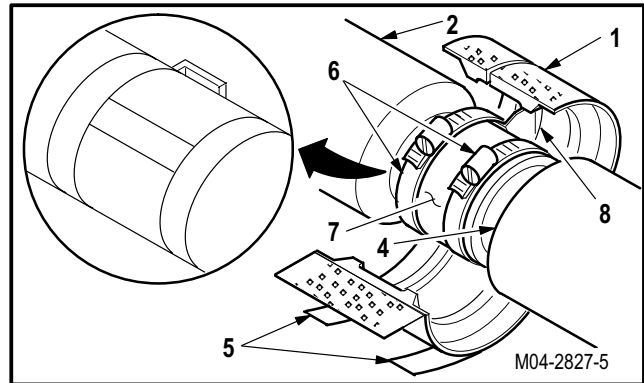

**c. Inspect (QA).**

**d. Install No. 2 transformer-rectifier (para 9.32).**

**e. Perform ECS maintenance operational check (TM 1-1520-238-T).**

**f. Install access panels L200 and R200 (para 2.2).**

END OF TASK

**13.24. AIR DUCT NO. 8 REMOVAL/INSTALLATION**

13.24.1. Description

This task covers: Removal. Cleaning. Inspection. Installation.

13.24.2. Initial Setup

**Tools:**

Aircraft mechanic's tool kit (item 376, App H)  
 Light duty laboratory apron (item 27, App H)  
 Chemical protective gloves (item 154, App H)  
 Adjustable air filtering respirator (item 262, App H)

**References:**

TM 1-1520-238-T

**Materials/Parts:**

Brush (item 34, App F)  
 Sealing compound (item 176, App F)  
 Tape (item 200, App F)

**Equipment Conditions:**

<u>Ref</u>	<u>Condition</u>
1.57	Helicopter safed
2.2	Access panel R200 removed
10.69	Refueling panel removed
9.32	No. 2 transformer-rectifier removed

**Personnel Required:**

67R Attack Helicopter Repairer  
 67R3F Attack Helicopter Repairer/Technical Inspector

13.24.3. Removal

- a. **Enter pilot station** (para 1.56). **Observe all safety precautions.**
- b. **On pilot aft circuit breaker panel, open ECS CAB circuit breaker.**

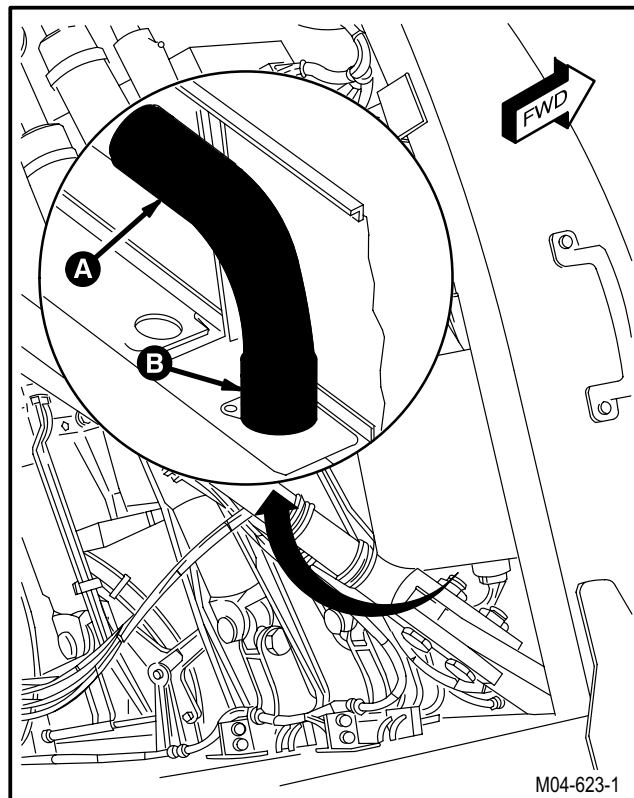

M04-623-1

GO TO NEXT PAGE

**13.24. AIR DUCT NO. 8 REMOVAL/INSTALLATION - continued**

**c. Remove two cuffs (1) and (2) from air duct No. 8 (3) and air duct (4).**

- (1) Remove sealing compound from cuff (1) and deck (5) (para 1.47).
- (2) Remove tape (6) and separate cuff (1).
- (3) Remove tape (6) and separate cuff (2) velcro strips.
- (4) Remove cuffs (1) and (2).

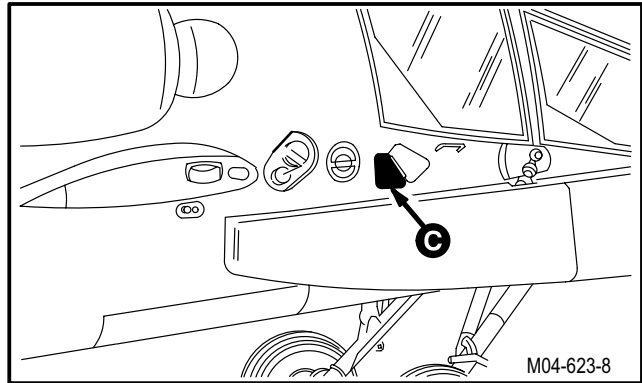

**d. Remove cuff (7) from ducts (3) and (8).**

- (1) Remove tape (6) and separate cuff (7) halves.
- (2) Remove cuff (7) halves.

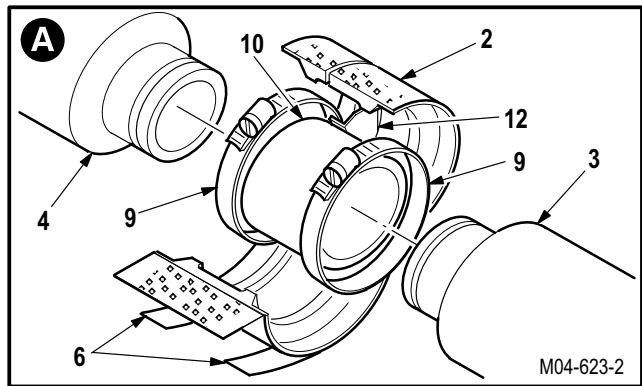

**e. Remove duct (3) from ducts (4) and (8).**

- (1) Loosen five clamps (9) from sleeve (10), flexible hose (11), and brackets (12) and (13).
- (2) Remove clamps (9), sleeve (10), and hose (11).
- (3) Remove duct (3).

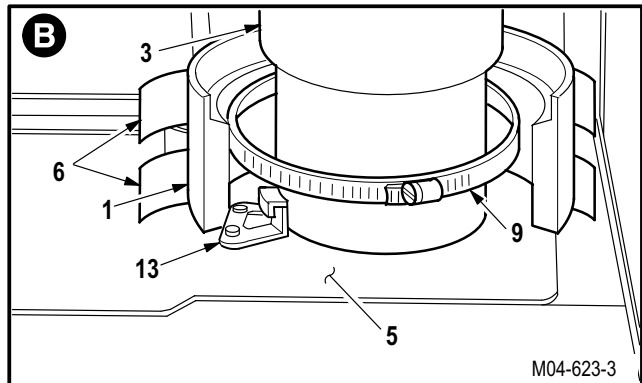

**13.24.4. Cleaning**

**a. Clean removed and attaching parts (para 1.47).**

**13.24.5. Inspection**

- a. Check ends of ducts, clamps, and brackets for excessive wear, cracks, or breaks (para 13.1).
- b. Check sleeves, cuffs, and insulation on ducts for rips or tears (para 13.1).
- c. Check rubber seals at both ends of ducts for chafing, cuts, or fraying (para 13.1).
- d. Check removed and attaching parts for corrosion (para 1.49).

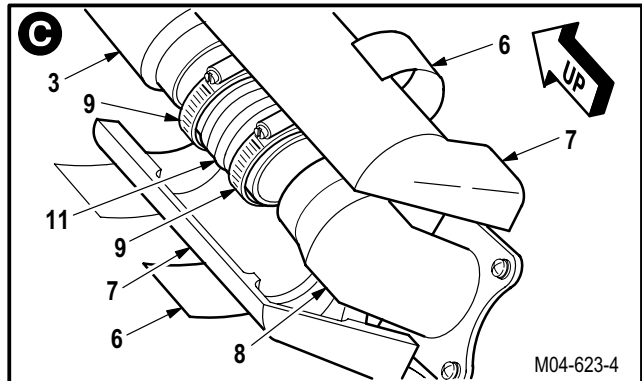

GO TO NEXT PAGE



**13.24. AIR DUCT NO. 8 REMOVAL/INSTALLATION - continued**

13.24.6. Installation

**a. Install duct (3) on ducts (4) and (8).**

- (1) Install two clamps (9) and hose (11) on duct (8).
- (2) Install three clamps (9) and sleeve (10) on duct (3).
- (3) Position duct (3) between ducts (4) and (8).
- (4) Center hose (11) over ducts (3) and (8).
- (5) Center sleeve (10) over ducts (3) and (4).
- (6) Position five clamps (9) over sleeve (10), hose (11), and brackets (12) and (13).
- (7) Tighten clamps (9).

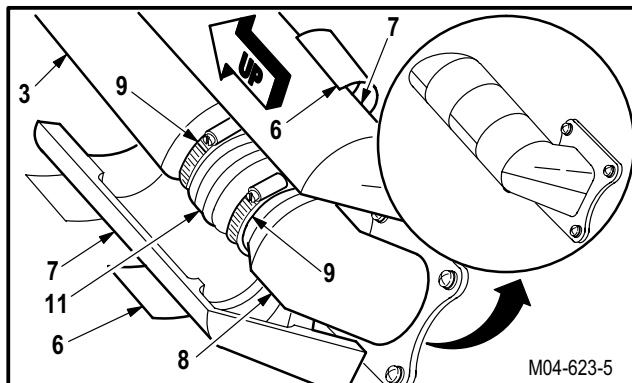

**b. Install cuff (7) on ducts (3) and (8).**

- (1) Position cuff (7) halves over ducts (3) and (8).
- (2) Install tape (6) on cuff (7) halves. Use tape (item 200, App F).

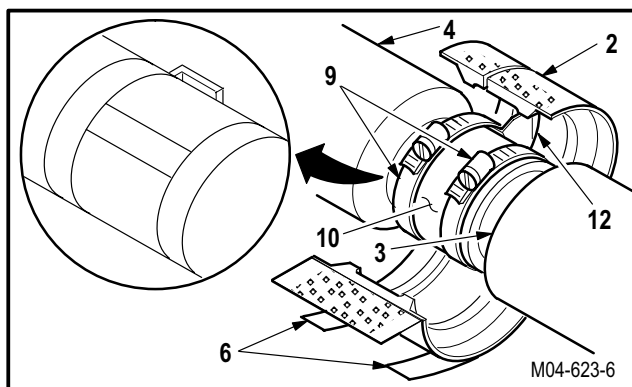

**c. Install two cuffs (1) and (2) on ducts (3) and (4).**

- (1) Position cuff (1) over duct (3) and position cuff (2) over ducts (3) and (4).
- (2) Secure cuff (2) velcro strips together.
- (3) Secure cuff (1). Use tape (item 200, App F).
- (4) Install tape (6) on cuffs (1) and (2). Use tape (item 200, App F).
- (5) Apply sealing compound around cuff (1) and deck (5). Use sealing compound (item 176, App F) and brush (item 34, App F).

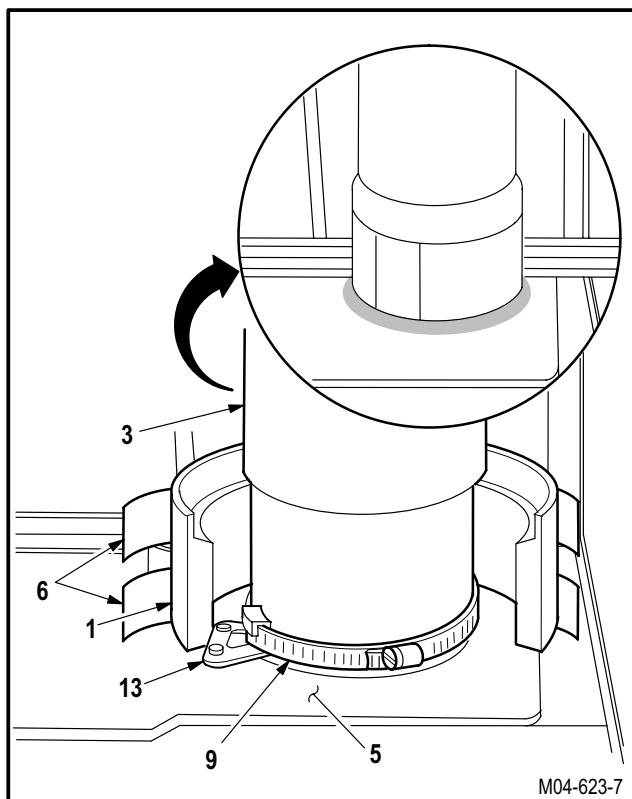

GO TO NEXT PAGE

---

**13.24. AIR DUCT NO. 8 REMOVAL/INSTALLATION - continued**

---

- d. **Inspect (QA).**
- e. **Install refueling panel** (para 10.69).
- f. **Install No. 2 transformer-rectifier** (para 9.32).
- g. **Perform ECS maintenance operational check** (TM 1-1520-238-T).
- h. **Install access panel R200** (para 2.2).

END OF TASK

**13.25. AIR DUCT NO. 9 REMOVAL/INSTALLATION**

13.25.1. Description

This task covers: Removal. Cleaning. Inspection. Installation.

13.25.2. Initial Setup

**Tools:**

Aircraft mechanic's tool kit (item 376, App H)

**References:**

TM 1-1520-238-T  
TM 11-1520-238-23-1

**Materials/Parts:**

Tape (item 200, App F)

**Equipment Conditions:**

<u>Ref</u>	<u>Condition</u>
1.57	Helicopter safed
2.2	Access panels PR2 and PR4 removed
10.69	Refueling panel removed
12.17	APU fire panel removed
TM 11-1520-238-23-1	ADF and IFF panels removed

**Personnel Required:**

67R Attack Helicopter Repairer  
67R3F Attack Helicopter Repairer/Technical Inspector

13.25.3. Removal

- a. **Enter pilot station (para 1.56). Observe all safety precautions.**
- b. **On pilot aft circuit breaker panel, open ECS CAB circuit breaker.**

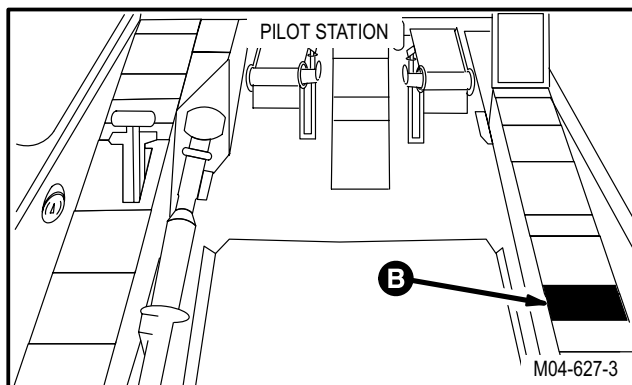
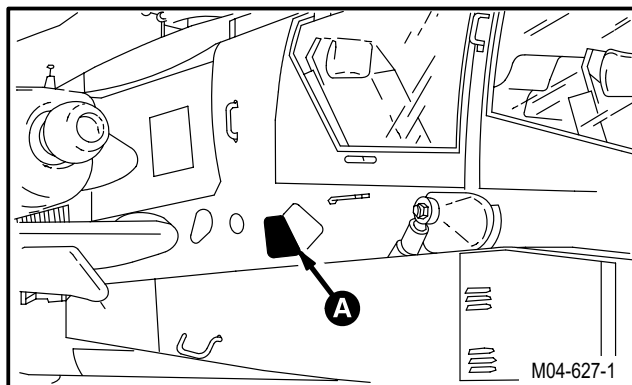

GO TO NEXT PAGE

13.25. AIR DUCT NO. 9 REMOVAL/INSTALLATION - continued

c. Remove cuff (1) from air duct No. 9 (2) and air duct (3).

- (1) Remove tape (4) and separate cuff (1) halves.
- (2) Remove cuff (1) halves.

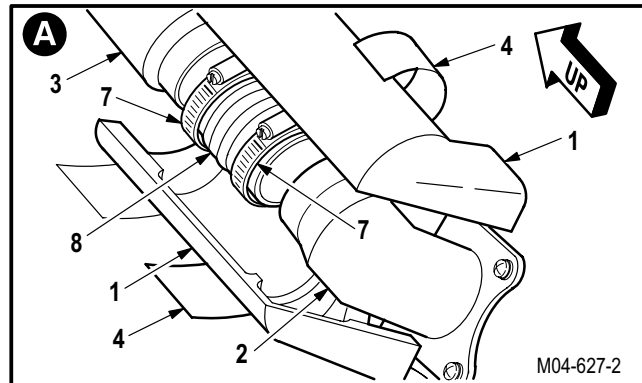

d. Remove duct (2) from ducts (3) and (5) and bulkhead (6).

- (1) Loosen two clamps (7) from flexible hose (8).
- (2) Enter pilot station (para 1.56). **Observe all safety precautions.**
- (3) Loosen two clamps (7) from sleeve (9).
- (4) Remove four screws (10), washers (11), and two clamps (12).
- (5) Remove clamps (7), hose (8), and sleeve (9).
- (6) Remove duct (2).

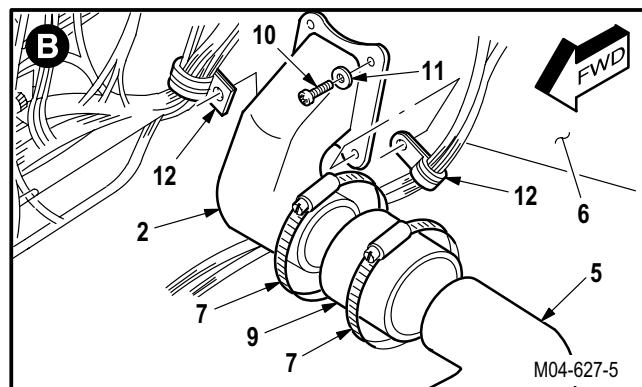

13.25.4. Cleaning

a. **Wipe removed and attaching parts with a clean rag.**

13.25.5. Inspection

- a. **Check ends of ducts, clamps, and brackets for excessive wear, cracks, or breaks** (para 13.1).
- b. **Check sleeves, cuffs, and insulation on ducts for rips or tears** (para 13.1).
- c. **Check rubber seals at both ends of ducts for chafing, cuts, or fraying** (para 13.1).
- d. **Check removed and attaching parts for corrosion** (para 1.49).

GO TO NEXT PAGE

---

**13.25. AIR DUCT NO. 9 REMOVAL/INSTALLATION - continued**



---

13.25.6. Installation**a. Install duct (2) on ducts (3) and (5) and bulkhead (6).**

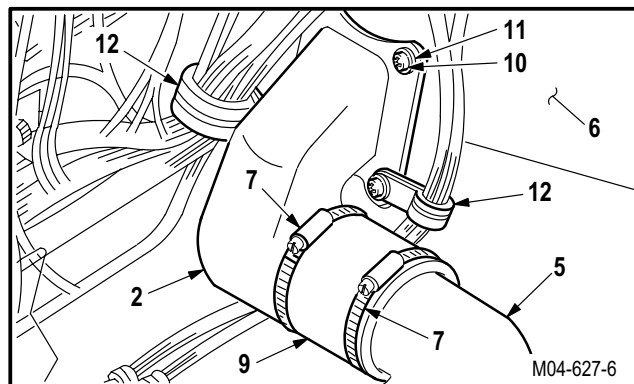
- (1) Install four clamps (7), hose (8), and sleeve (9) on duct (2).
- (2) Enter pilot station (para 1.56). **Observe all safety precautions.**
- (3) Position duct (2) on bulkhead (6) between ducts (3) and (5).
- (4) Install four screws (10), washers (11), and two clamps (12) on duct (2).
- (5) Center hose (8) over ducts (2) and (3).
- (6) Center sleeve (9) over ducts (2) and (5).
- (7) Position clamps (7) over hose (8) and sleeve (9).
- (8) Tighten clamps (7).

**b. Install cuff (1) on ducts (2) and (3).**

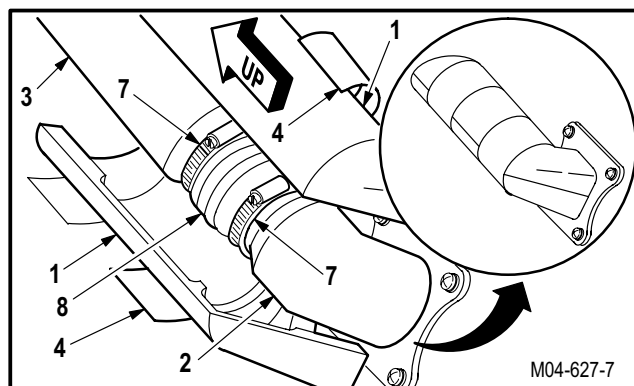
- (1) Position cuff (1) halves over ducts (2) and (3).
- (2) Install tape (4) on cuff (1) halves. Use tape (item 200, App F).



GO TO NEXT PAGE

---

**13.25. AIR DUCT NO. 9 REMOVAL/INSTALLATION - continued**

---

- c. **Inspect (QA).**
- d. **Install APU fire panel** (para 12.17).
- e. **Install ADF and IFF panels** (TM 11-1520-238-23-1).
- f. **Install refueling panel** (para 10.69).
- g. **Perform ECS maintenance operational check** (TM 1-1520-238-T).
- h. **Install access panels PR2 and PR4** (para 2.2).

END OF TASK

**13.26. AIR DUCT NO. 10 REMOVAL/INSTALLATION**

13.26.1. Description

This task covers: Removal. Cleaning. Inspection. Repair. Installation.

13.26.2. Initial Setup

**Tools:**

- Aircraft mechanic's tool kit (item 376, App H)
- Light duty laboratory apron (item 27, App H)
- Chemical protective gloves (item 154, App H)
- Adjustable air filtering respirator (item 262, App H)

**Personnel Required:**

- 67R Attack Helicopter Repairer
- One person to assist
- 67R3F Attack Helicopter Repairer/Technical Inspector

**References:**

TM 1-1520-238-T

**Equipment Conditions:**

<u>Ref</u>	<u>Condition</u>
1.57	Helicopter safed
13.21	Air duct No. 5 removed

**Materials/Parts:**

- Gasket
- Adhesive (item 16, App F)

13.26.3. Removal

- a. **Enter pilot station** (para 1.56). **Observe all safety precautions.**
- b. **On pilot aft circuit breaker panel, open ECS CAB circuit breaker.**
- c. **Remove air duct No. 10 (1) from bulkhead (2) and duct (3).**
  - (1) Remove six screws (4) and washers (5).

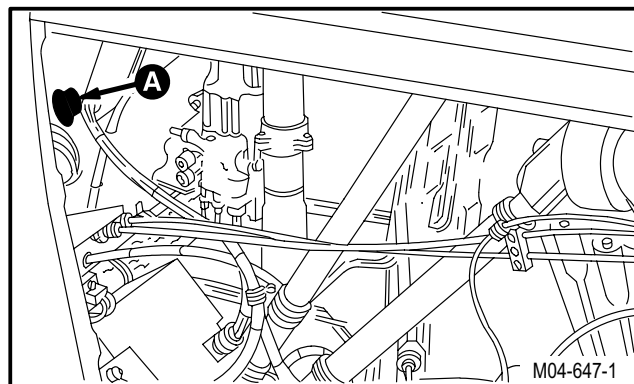

13.26.4. Cleaning

- a. **Wipe removed and attaching parts with a clean rag.**

13.26.5. Inspection

- a. **Check ends of ducts, clamps, and brackets for excessive wear, cracks, or breaks** (para 13.1).
- b. **Check rubber seals at both ends of ducts for chafing, cuts, or fraying** (para 13.1).

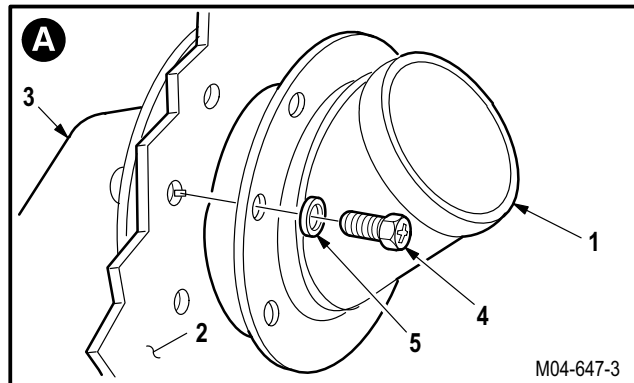

GO TO NEXT PAGE

**13.26. AIR DUCT NO. 10 REMOVAL/INSTALLATION - continued**

- c. **Check gasket on duct for cuts or gouges.** Replace defective gasket.
- d. **Check bulkhead for cracks and elongation of holes** (para 2.11).
- e. **Check removed and attaching parts for corrosion** (para 1.49).

13.26.6. Repair

- a. **Remove gasket (6) from duct (1).**
- b. **Clean duct (1)** (para 1.47).



- c. **Install new gasket (6) on duct (1).**

- (1) Apply adhesive on mating surfaces of gasket (6) and duct (1). Use adhesive (item 16, App F).
- (2) Position gasket (6) on duct (1).

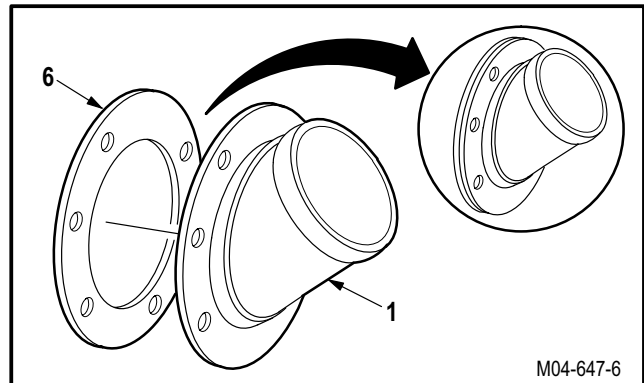

13.26.7. Installation

- a. **Install duct (1) on bulkhead (2) and duct (3).**

- (1) Position duct (1) on bulkhead (2).
- (2) Enter pilot station (para 1.56). **Observe all safety precautions.**
- (3) One person align duct (3) with holes in bulkhead (2).
- (4) Install six screws (4) and washers (5).

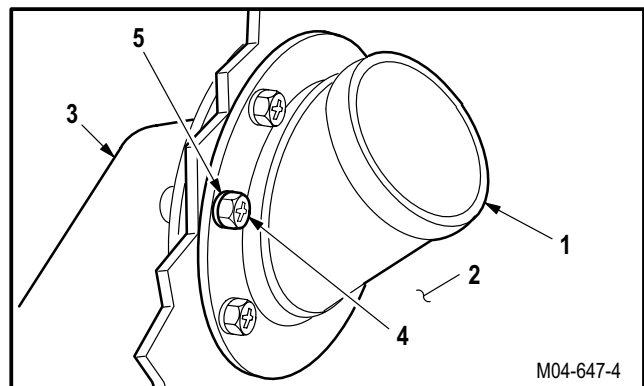

- b. **Inspect (QA).**
- c. **Install air duct No. 5** (para 13.21).
- d. **Perform ECS maintenance operational check** (TM 1-1520-238-T).

END OF TASK



**13.27. AIR DUCT NO. 11 REMOVAL/INSTALLATION**

13.27.1. Description

This task covers: Removal. Cleaning. Inspection. Installation.

13.27.2. Initial Setup

**Tools:**

- Aircraft mechanic's tool kit (item 376, App H)
- Light duty laboratory apron (item 27, App H)
- Chemical protective gloves (item 154, App H)
- Adjustable air filtering respirator (item 262, App H)

**References:**

TM 1-1520-238-T

**Materials/Parts:**

- Gasket
- Adhesive (item 16, App F)

**Equipment Conditions:**

<u>Ref</u>	<u>Condition</u>
1.57	Helicopter safed
2.161	Tilt pilot seat forward
12.47	Pilot anti-ice panel removed
13.26	Air duct No. 10 removed

**Personnel Required:**

- 67R Attack Helicopter Repairer
- 67R3F Attack Helicopter Repairer/Technical Inspector

13.27.3. Removal

- a. **Enter pilot station (para 1.56). Observe all safety precautions.**

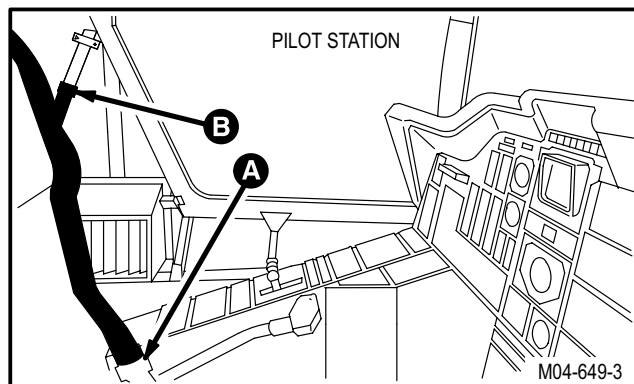

GO TO NEXT PAGE

**13.27. AIR DUCT NO. 11 REMOVAL/INSTALLATION - continued**

**b. Remove duct No. 11 (1) from air ducts (2) and (3).**

- (1) Loosen four clamps (4) from sleeve (5) and flex hose (6).
- (2) Remove clamps (4), sleeve (5), and hose (6).
- (3) Remove duct (1).

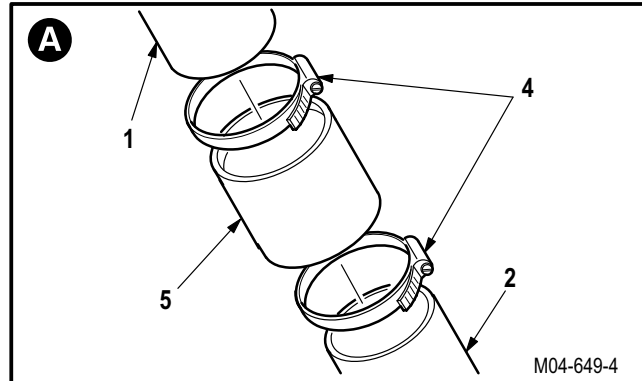

**13.27.4. Cleaning**

**a. Wipe removed and attaching parts with a clean rag.**

**13.27.5. Inspection**

- a. **Check ends of ducts, clamps, and brackets for excessive wear, cracks, or breaks** (para 13.1).
- b. **Check sleeves, cuffs, and insulation on ducts for rips or tears** (para 13.1).
- c. **Check rubber seals at both ends of ducts for chafing, cuts, or fraying** (para 13.1).
- d. **Check bulkhead for cracks and elongation of holes** (para 13.1).
- e. **Check gasket on duct for cuts or gouges. Replace defective gasket.**
- f. **Check duct nutplates for loose rivets and stripped or damaged threads** (para 13.1).
- g. **Check removed and attaching parts for corrosion** (para 1.49).

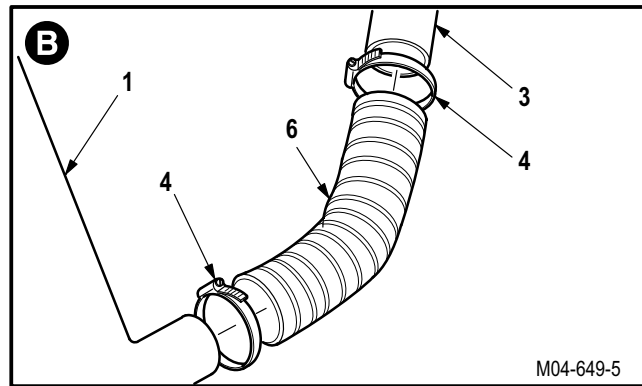

GO TO NEXT PAGE

**13.27. AIR DUCT NO. 11 REMOVAL/INSTALLATION - continued**

13.27.6. Repair

a. **Remove gasket (7) from duct (1).**

b. **Clean duct (1)** (para 1.47).



c. **Install new gasket (7) on duct (1).**

(1) Apply adhesive on mating surfaces of gasket (7) and duct (1). Use adhesive (item 16, App F).

(2) Position gasket (7) on duct (1).

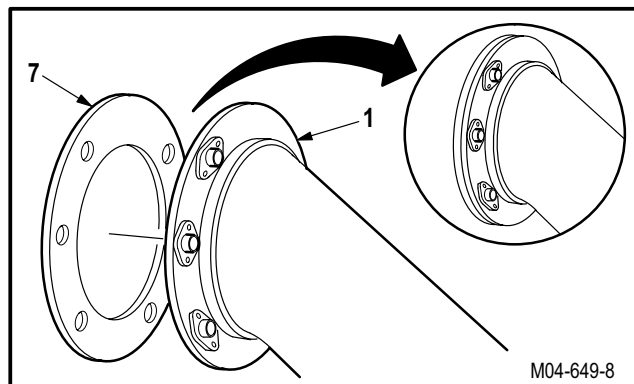

13.27.7. Installation

a. **Install duct (1) on ducts (2) and (3).**

(1) Install two clamps (4) and sleeve (5) on duct (2).

(2) Install two clamps (4) and hose (6) on duct (3).

(3) Position duct (1) between ducts (2) and (3).

(4) Center sleeve (5) over ducts (1) and (2).

(5) Center hose (6) over ducts (1) and (3).

(6) Position clamps (4) over sleeves (5) and hose (6).

(7) Tighten clamps (4).

b. **Install air duct No. 10** (para 13.26).

c. **Inspect (QA).**

d. **Install pilot anti-ice panel** (para 12.47).

e. **Tilt pilot seat back** (para 2.161).

f. **Perform ECS maintenance operational check** (TM 1-1520-238-T).

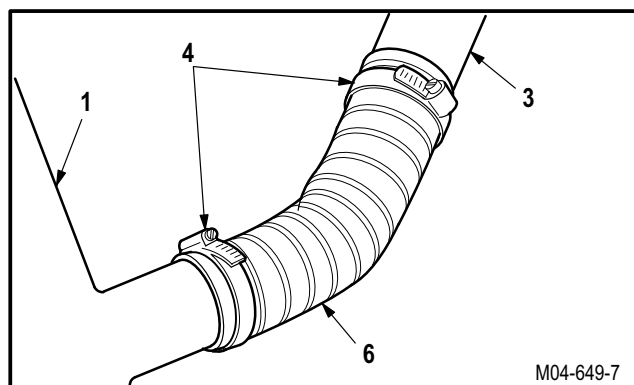
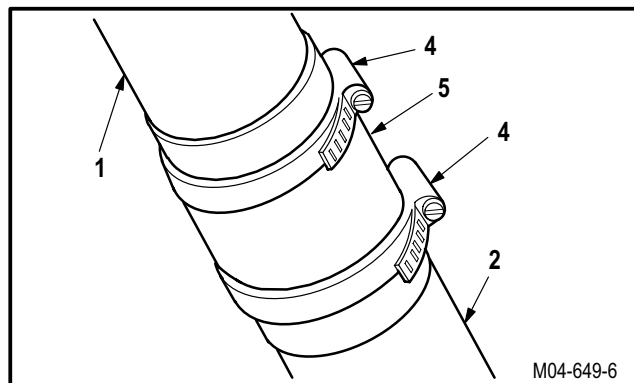

END OF TASK

**13.28. ECS CREW STATION DUCTS REMOVAL/INSTALLATION**

13.28.1. Description

This task covers: Removal. Cleaning. Inspection. Installation.

13.28.2. Initial Setup

**Tools:**

- Aircraft mechanic's tool kit (item 376, App H)
- Light duty laboratory apron (item 27, App H)
- Chemical protective gloves (item 154, App H)
- Adjustable air filtering respirator (item 262, App H)

**Personnel Required:**

- 67R Attack Helicopter Repairer
- 67R3F Attack Helicopter Repairer/Technical Inspector

**References:**

TM 1-1520-238-T

**Equipment Conditions:**

<u>Ref</u>	<u>Condition</u>
1.57	Helicopter safed
2.161	Remove pilot/CPG seat (if required)
2.2	Appropriate fairings and doors removed and opened

**Materials/Parts:**

- Gasket(s)
- Adhesive (item 13, App F)
- Adhesive (item 16, App F)
- Tape (item 208, App F)

**NOTE**

Although ducts differ in configuration and location, this task is typical for removal and installation of crew station ducts 12 thru 33 and associated components.

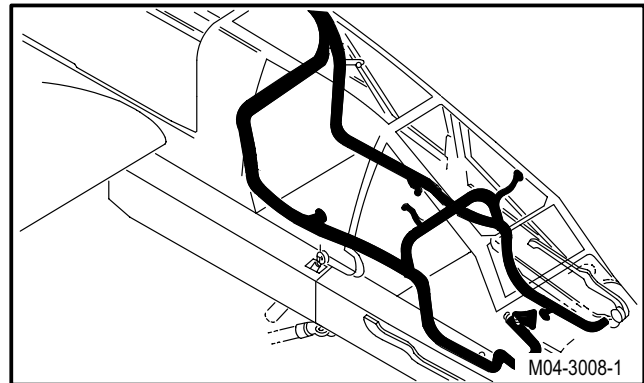

GO TO NEXT PAGE

13.28. ECS CREW STATION DUCTS REMOVAL/INSTALLATION - continued

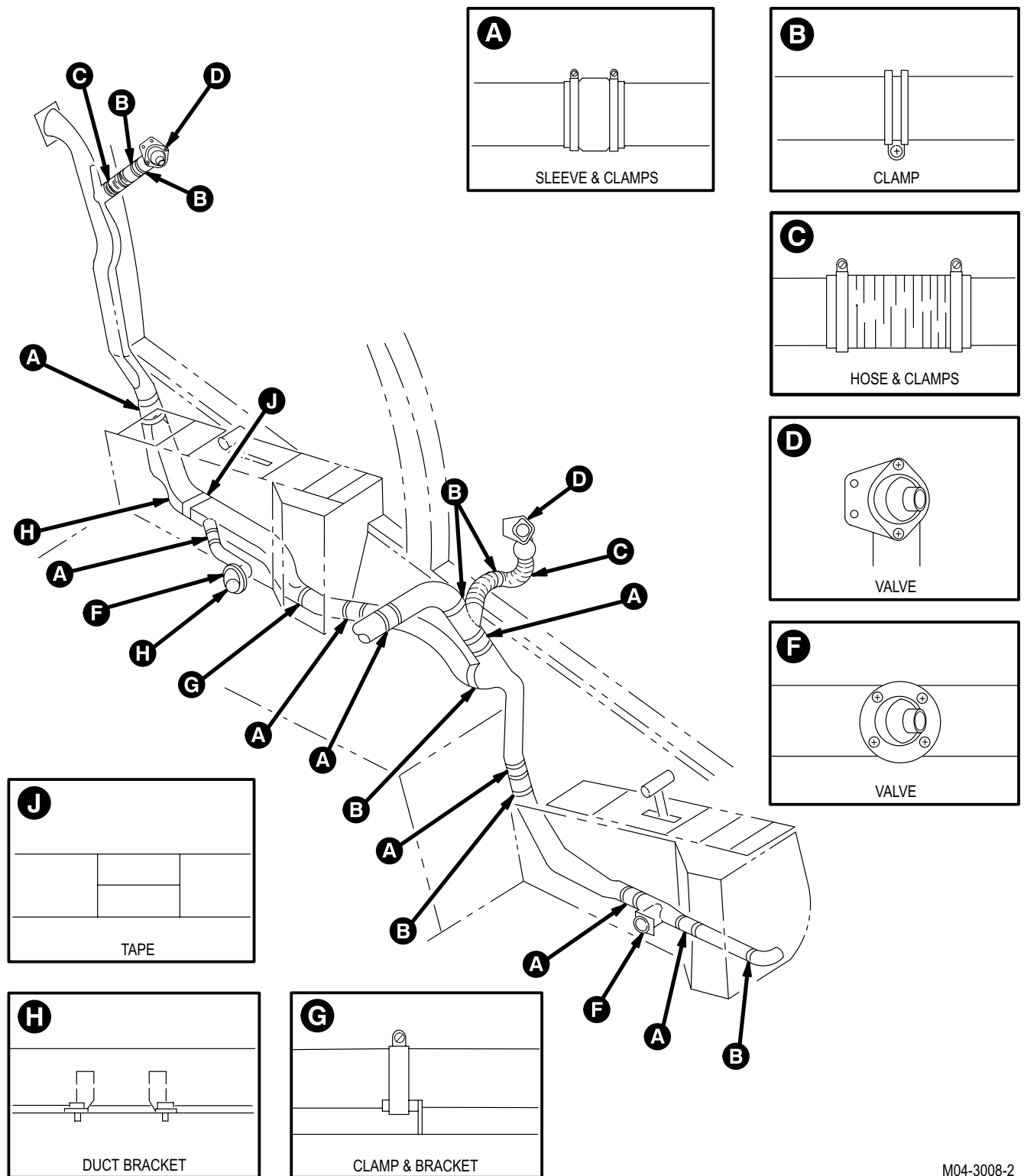

M04-3008-2

GO TO NEXT PAGE

13.28. ECS CREW STATION DUCTS REMOVAL/INSTALLATION - continued

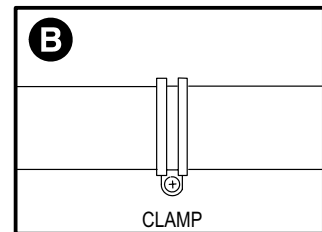
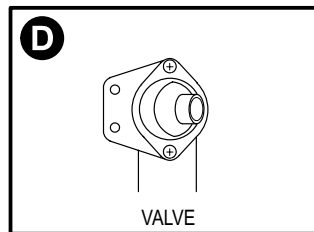
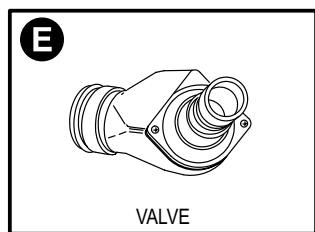
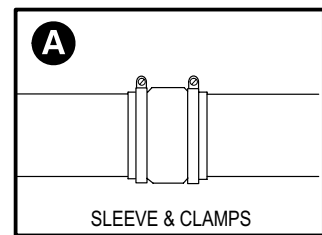
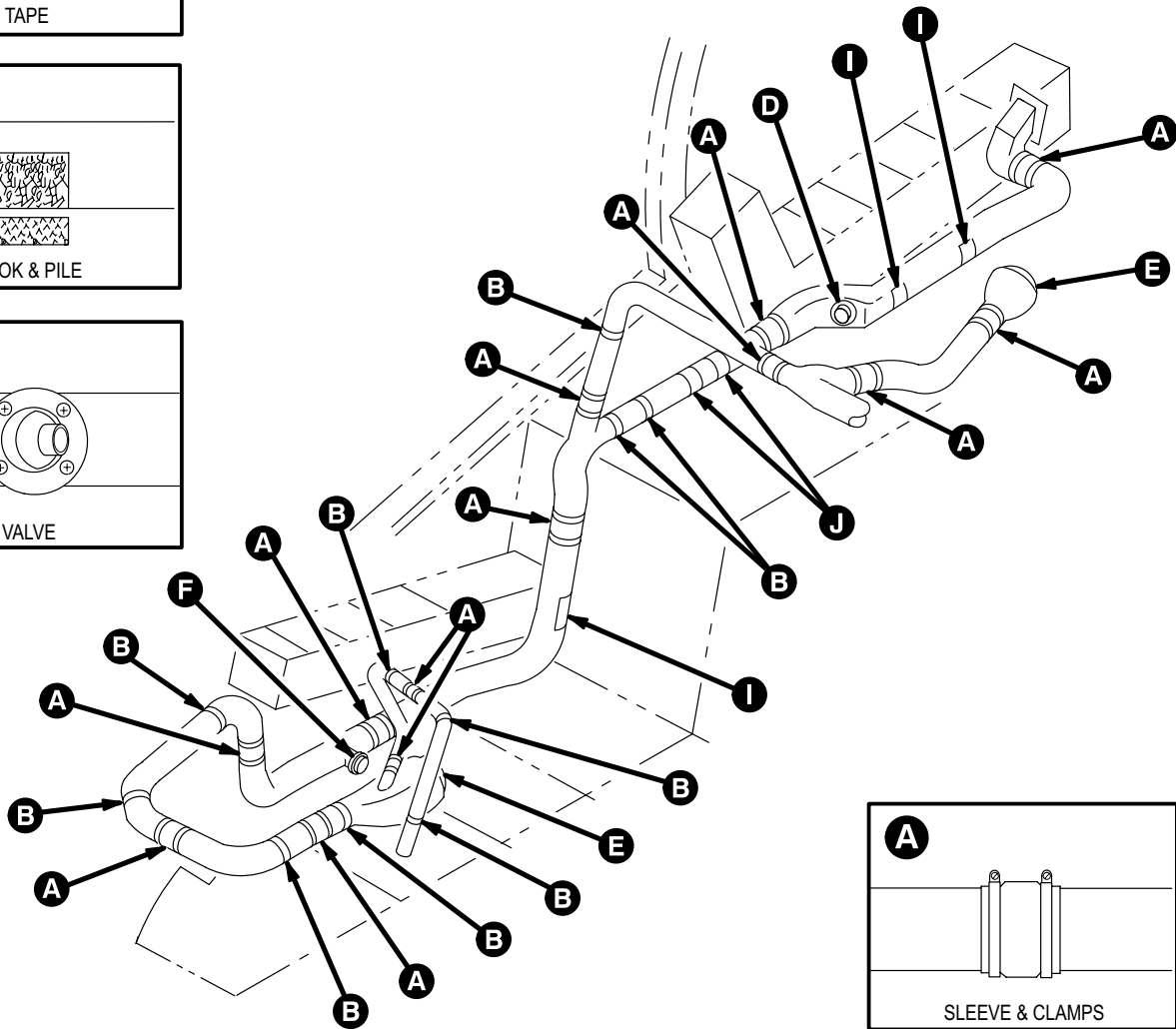
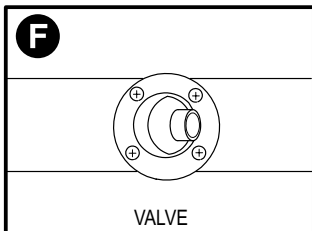
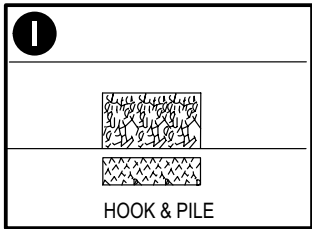
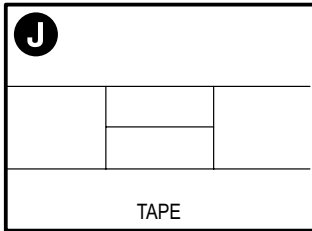

M04-3008-3

GO TO NEXT PAGE

**13.28. ECS CREW STATION DUCTS REMOVAL/INSTALLATION - continued****13.28.3. Removal****a. Remove sleeve (1) from ducts (2) and (3).**

(1) Remove two clamps (4).

(2) Remove sleeve (1).

**NOTE**

Some clamp stack-ups will have spacers or nuts.

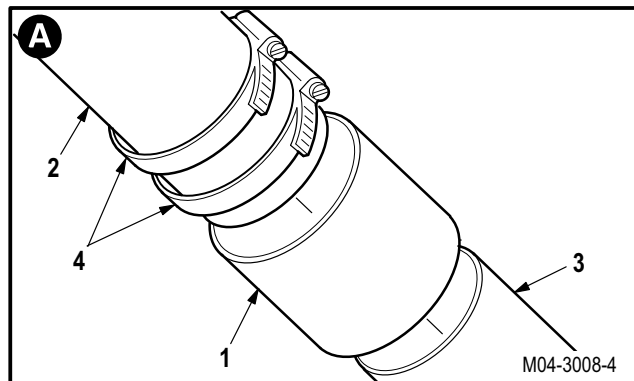
**b. Remove clamp (5) from duct (6).**

(1) Remove screw (7) and washer (8) from air-frame (9).

(2) Remove clamp (5).

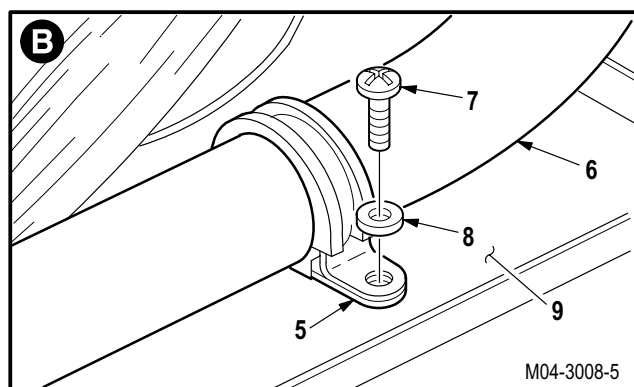
**c. Remove flex hose (10) from ducts (11) and (12).**

(1) Remove two clamps (13) from hose (10).

(2) Remove hose (10).

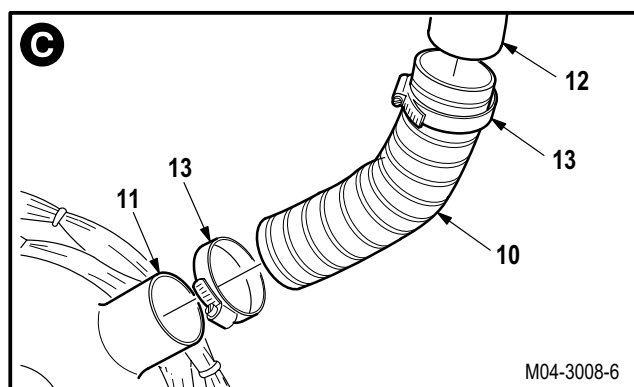
**d. Remove valve (14) from duct (15).**

(1) Remove two screws (16) and washers (17).

(2) Remove valve (14).

(3) Remove adhesive from valve (14) and duct (15) (para 1.47).

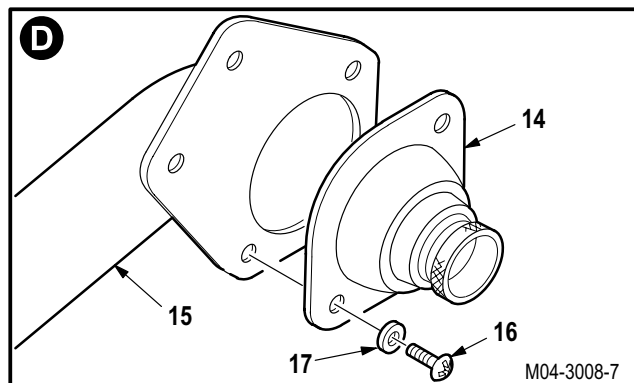

GO TO NEXT PAGE

**13.28. ECS CREW STATION DUCTS REMOVAL/INSTALLATION - continued**

**e. Remove valve (18) from duct (19).**

- (1) Remove two screws (20) and washers (21) from valve (18).
- (2) Remove valve (18).
- (3) Remove adhesive from valve (18) and duct (19) (para 1.47).

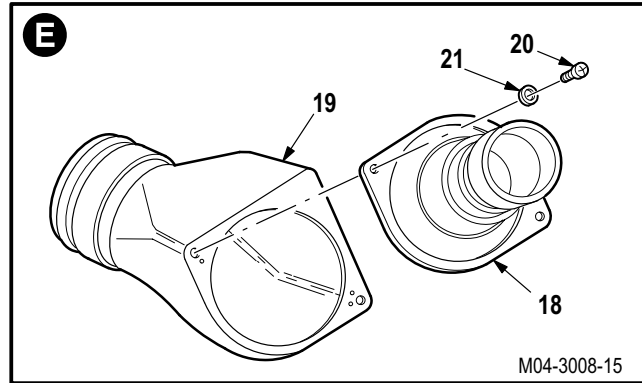

**f. Remove valve (22) from duct (23).**

- (1) Remove four screws (24) and washers (25).
- (2) Remove valve (22). Discard gasket (26).
- (3) Remove adhesive from valve (22) and duct (23) (para 1.47).

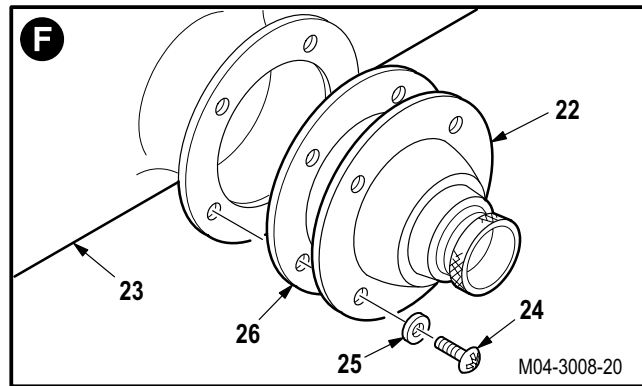

**g. Remove clamp (27) from bracket (28).**

- (1) Loosen clamp (27).
- (2) Slide clamp (27) on duct (29).

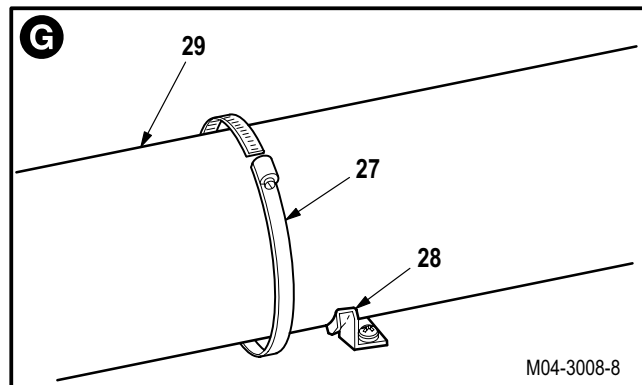

GO TO NEXT PAGE



**13.28. ECS CREW STATION DUCTS REMOVAL/INSTALLATION - continued**

**h. Remove duct (30) from helicopter.**

- (1) Remove two screws (31) and washers (32) from duct (30).
- (2) Pull duct (30) and pile (33) from hook (34).
- (3) Remove duct (30).

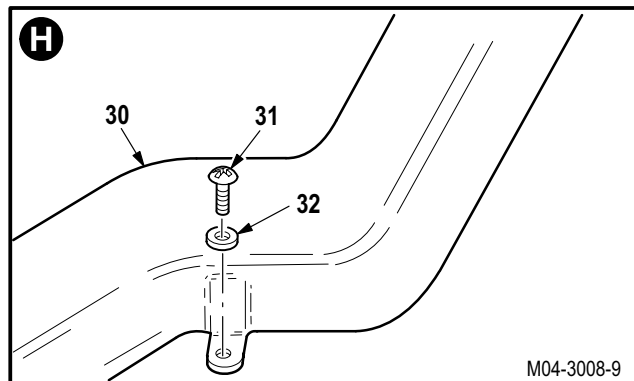

**13.28.4. Cleaning**

- a. **Clean removed and attaching parts** (para 1.47).

**13.28.5. Inspection**

- a. **Check ends of ducts, clamps, and brackets for excessive wear, cracks, or breaks** (para 13.1).
- b. **Check sleeves, cuffs, and insulation on ducts for rips or tears** (para 13.1).
- c. **Check rubber seals at both ends of ducts for chafing, cuts, or fraying** (para 13.1).
- d. **Check duct nutplates for loose rivets and stripped or damaged threads** (para 13.1).
- e. **Check removed and attaching parts for corrosion** (para 1.49).

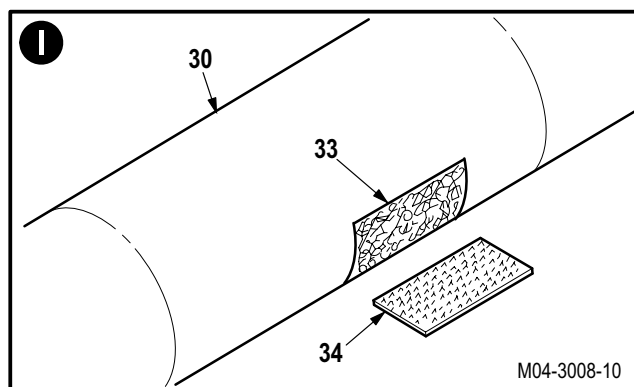

- f. **Check hook-and-pile fasteners for tears, cracks, or loose attachment.**

- (1) If pile (33) or hook (34) is debonding from duct or floor, attach with adhesive. Use adhesive (item 13, App F).

**13.28.6. Installation**

**NOTE**

Tape may be applied to duct wherever chafing is occurring. Tape may not be used to repair ducts with holes, cracks, etc.

- a. **Wrap duct (35) with one revolution of tape (36).** Use tape (item 208, App F).

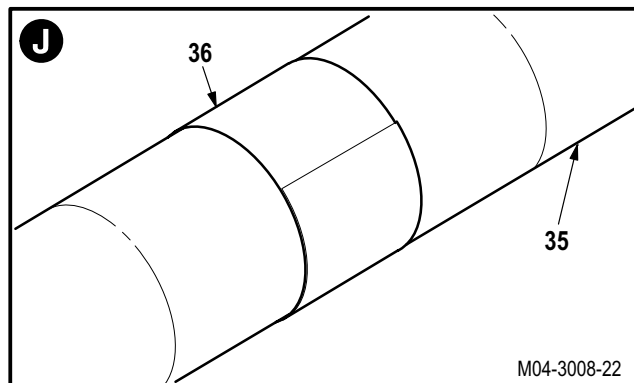

GO TO NEXT PAGE

**13.28. ECS CREW STATION DUCTS REMOVAL/INSTALLATION - continued**

**b. Install duct (30) in helicopter.**

- (1) Aline duct (30) and pile (33) with hook (34).

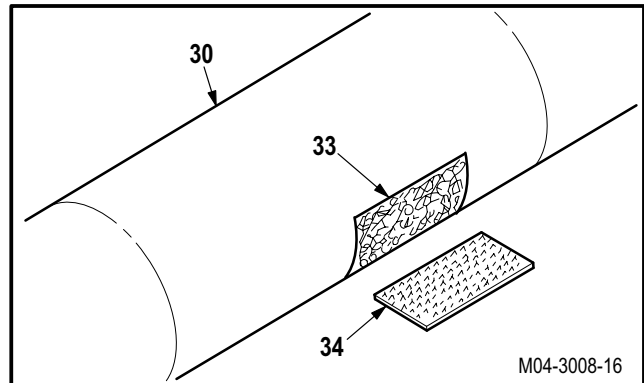

- (2) Install two screws (31) and washers (32) on duct (30).

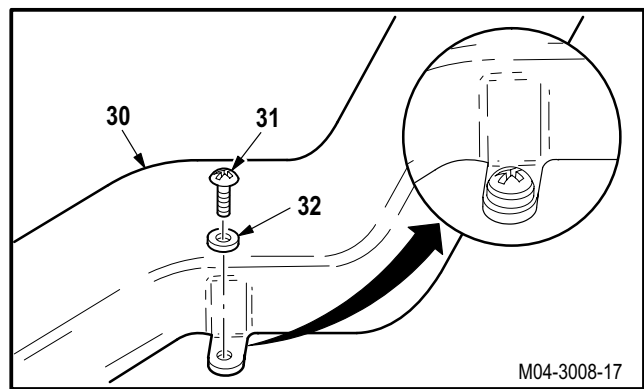

**c. Install clamp (27) on duct (29) and bracket (28).**

- (1) Slide clamp (27) over bracket (28).
- (2) Install clamp (27).

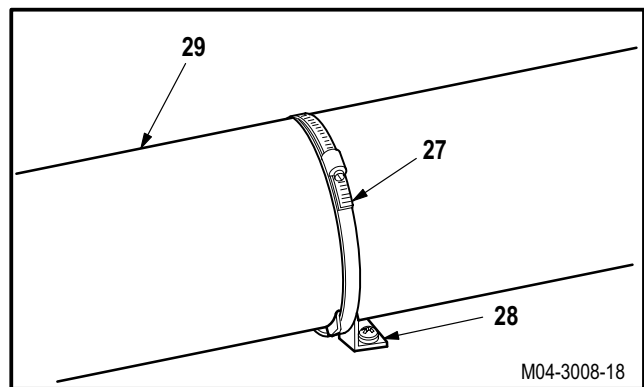

**d. Install valve (22) on duct (23).**

- (1) Apply an even bead of adhesive on both sides of new gasket (26). Use adhesive (item 16, App F).
- (2) Position and install gasket (26) on duct (23).
- (3) Position valve (22) on gasket (26). Install four screws (24) through washers (25), valve (22), and gasket (26) into duct (23).

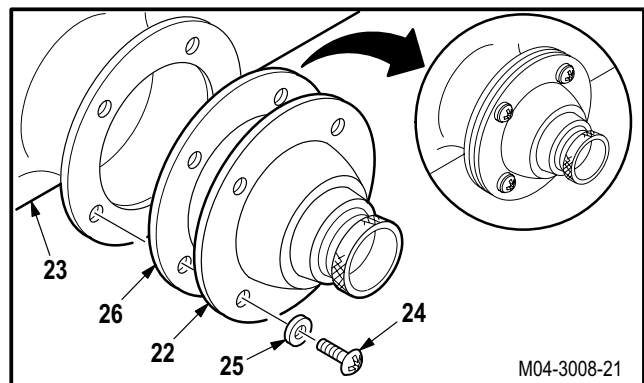

GO TO NEXT PAGE

**13.28. ECS CREW STATION DUCTS REMOVAL/INSTALLATION - continued**

**e. Install valve (18) on duct (19).**

- (1) Apply an even bead of adhesive on mating surfaces of valve (18) and duct (19). Use adhesive (item 16, App F).
- (2) Position valve (18) on duct (19).
- (3) Install two screws (20) through washers (21) and valve (18) into duct (19).

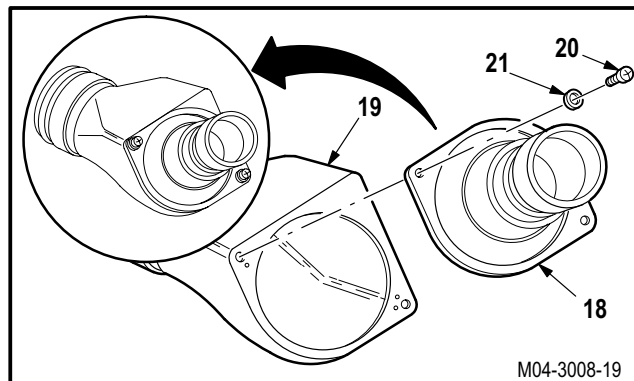

**f. Install valve (14) on duct (15).**

- (1) Apply an even bead of adhesive on mating surfaces of valve (14) and duct (15). Use adhesive (item 16, App F).
- (2) Position valve (14) on duct (15).
- (3) Install two screws (16) through washers (17) and valve (14) into duct (15).

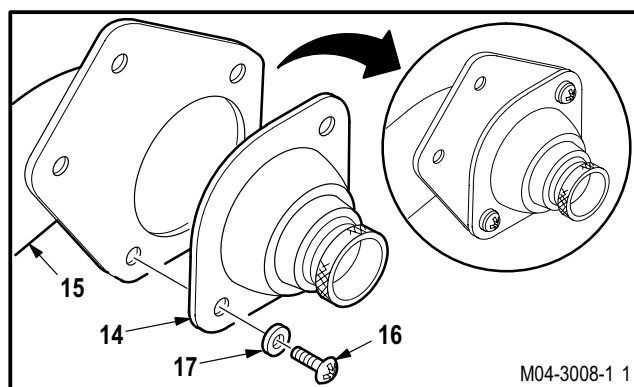

**g. Install hose (10) on ducts (11) and (12).**

- (1) Install hose (10) on duct (11).
- (2) Install two clamps (13) on hose (10).
- (3) Install hose (10) on duct (12).
- (4) Tighten clamps (13).

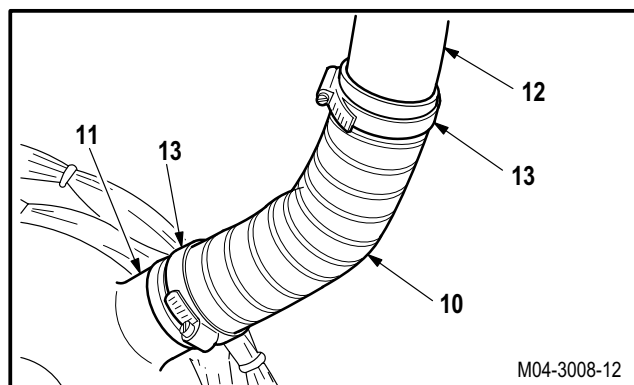

**NOTE**

Some clamp stack-ups will have spacers or nuts.

**h. Install clamp (5) on duct (6).**

- (1) Position clamp (5) on duct (6).
- (2) Install screw (7) through washer (8) and clamp (5) into airframe (9).

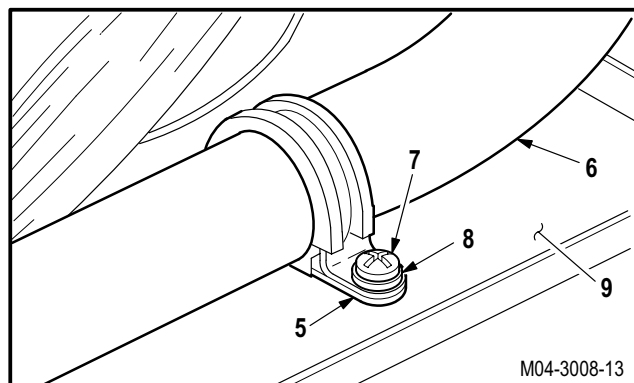

GO TO NEXT PAGE

---

**13.28. ECS CREW STATION DUCTS REMOVAL/INSTALLATION - continued**

---

**i. Install sleeve (1) on ducts (2) and (3).**

- (1) Install sleeve (1) and two clamps (4) on duct (3).
- (2) Center sleeve (1) over ducts (2) and (3).
- (3) Tighten two clamps (4).

**j. Inspect (QA).**

**k. Perform ECS maintenance operational check (TM 1-1520-238-T).**

**l. Install pilot/CPG seat (if required) (para 2.161).**

**m. Install and secure appropriate fairings and doors (para 2.2).**

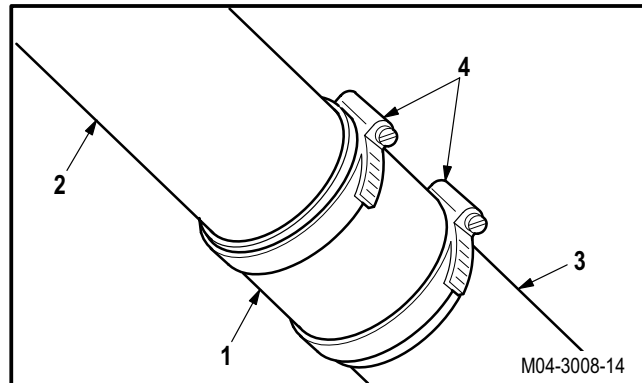

END OF TASK

---

## 13.29. ECS DUCT SEAL REPLACEMENT

---

### 13.29.1. Description

This task covers: Removal. Cleaning. Inspection. Installation.

---

### 13.29.2. Initial Setup

#### Tools:

Aircraft mechanic's tool kit (item 376, App H)  
 Light duty laboratory apron (item 27, App H)  
 Chemical protective gloves (item 154, App H)  
 1 1/4-inch blade putty knife (item 199, App H)  
 Adjustable air filtering respirator (item 262, App H)

#### Materials/Parts:

Rubber strip seal (App D)  
 Adhesive (item 14, App F)

#### Personnel Required:

67R Attack Helicopter Repairer  
 67R3F Attack Helicopter Repairer/Technical Inspector

#### Equipment Conditions:

<u>Ref</u>	<u>Condition</u>
13.28	Appropriate ECS duct removed

---

### NOTE

This task is typical for all ECS ducts.

### 13.29.3. Removal

#### a. Remove seal (1) from duct (2).

- (1) Note location of seal (1) on duct (2).
- (2) Remove seal (1). Use putty knife.
- (3) Remove and discard seal (1) from duct (2).

### 13.29.4. Cleaning

- a. **Clean duct** (para 1.47).
- b. **Clean new seal** (para 1.47).

### 13.29.5. Inspection

- a. **Check duct for cracks** (para 13.1).

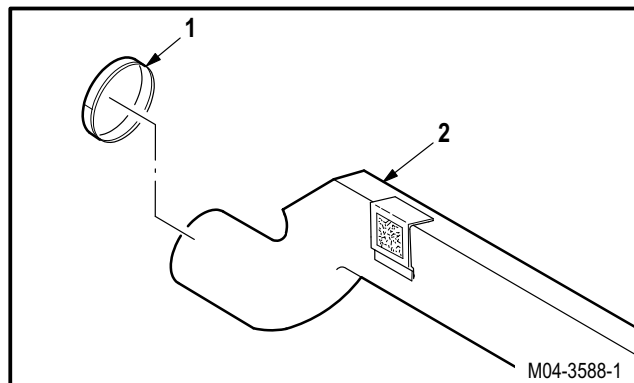

GO TO NEXT PAGE

---

**13.29. ECS DUCT SEAL REPLACEMENT - continued**

---

13.29.6. Installation



**a. Install new seal (1) on duct (2).**

(1) Apply an even bead of adhesive on seal (1).  
Use adhesive (item 14, App F).

(2) Install seal (1) at location noted on duct (2).

**b. Allow adhesive to dry 24 HOURS at 65 °F minimum.**

**c. Inspect (QA).**

**d. Install appropriate ECS duct (para 13.28).**

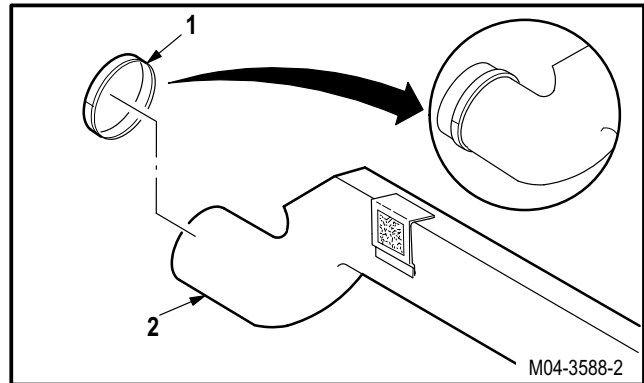

END OF TASK

**13.30. FORWARD AVIONICS BAY VANEAXIAL FAN REMOVAL/INSTALLATION**

13.30.1. Description

This task covers: Removal. Cleaning. Inspection. Installation.

13.30.2. Initial Setup

**Tools:**

- Aircraft mechanic's tool kit (item 376, App H)
- Electrical tool kit (item 378, App H)
- Light duty laboratory apron (item 27, App H)
- Chemical protective gloves (item 154, App H)
- Adjustable air filtering respirator (item 262, App H)

**References:**

- TM 1-1520-238-T
- TM 55-1500-323-24

**Materials/Parts:**

- Sealing compound (item 178, App F)

**Equipment Conditions:**

<u>Ref</u>	<u>Condition</u>
1.57	Helicopter safed
2.2	Access panel L60 or R60 removed
9.54	TB 305 track assembly removed, if removing left fan
13.31	Left or right forward avionics bay vaneaxial fan air duct removed

**Personnel Required:**

- 67R Attack Helicopter Repairer
- 68X Armament/Electrical System Repairer
- 67R3F Attack Helicopter Repairer/Technical Inspector

**NOTE**

This task is typical for the left or right forward avionics bay vaneaxial fans.

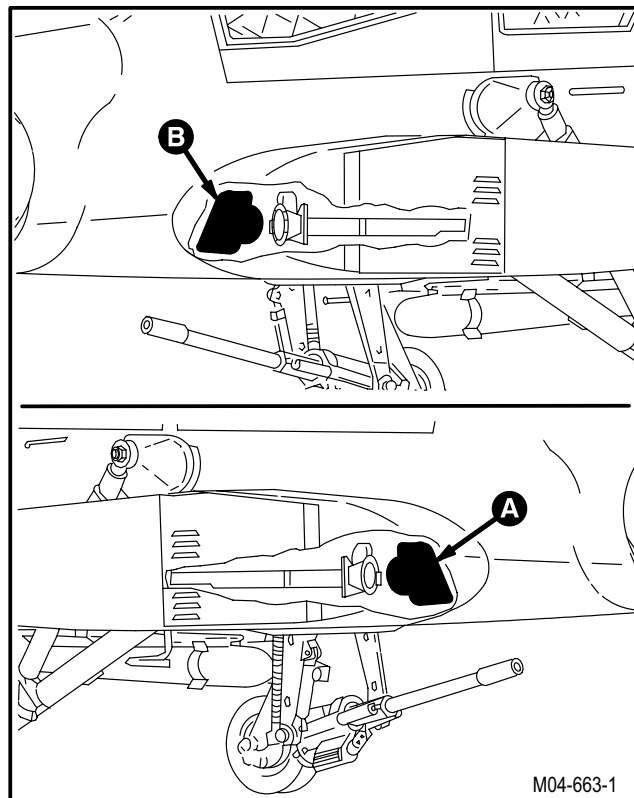

M04-663-1

GO TO NEXT PAGE

**13.30. FORWARD AVIONICS BAY VANEAXIAL FAN REMOVAL/INSTALLATION - continued**

13.30.3. Removal

**NOTE**

If removing the right fan, go to step a. If removing the left fan, go to step b.

**a. Remove fan wire harness (1) from bracket (2) and fan (3).**

- (1) Remove screw (4), washer (5), and clamps (6) and (7) from bracket (2).
- (2) Remove sealing compound from four screws (8) (para 1.47).
- (3) Remove screw (8), washer (9), and clamp (10) from fan (3).
- (4) Remove clamps (6) and (10) from fan wire harness (1).
- (5) Go to step d.

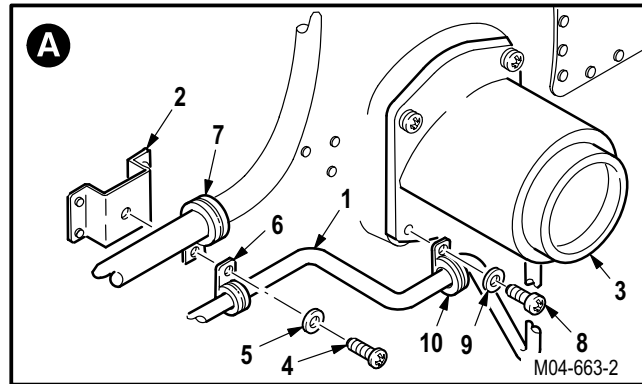

**b. Remove fan wire harness (1) from bracket (11) and fan (3).**

- (1) Remove screw (12), washer (13), clamp (14), spacer (15), and clamps (16) and (17) from fan wire harness (1).
- (2) Remove sealing compound from four screws (8) (para 1.47).
- (3) Remove screw (8), washer (9), and clamp (18) from fan (3).
- (4) Remove clamps (16) and (18) from fan wire harness (1).

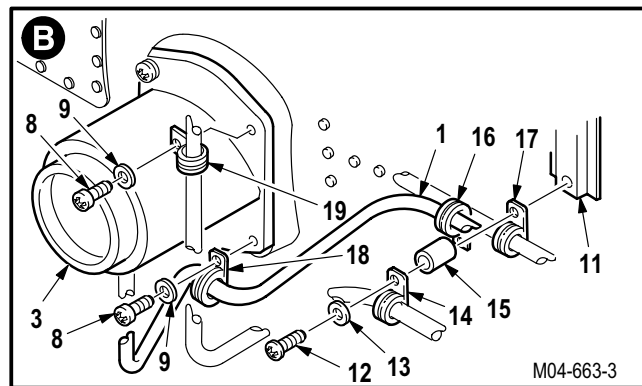

**c. Remove screw (8), washer (9), and clamp (19) from fan (3).**

**d. Identify and detach fan electrical wires (20) from splices (21) on wire harness (22) (W118 left or W119 right) (TM 55-1500-323-24).**

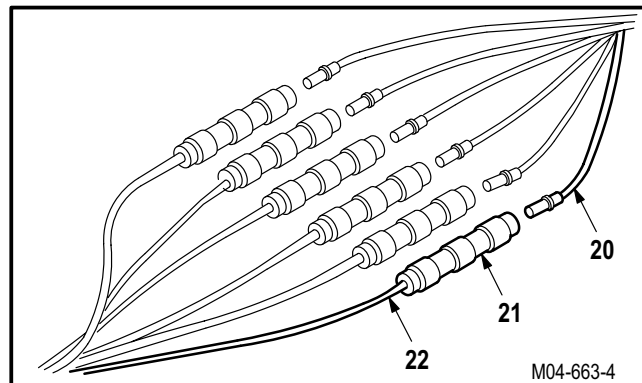

GO TO NEXT PAGE



**13.30. FORWARD AVIONICS BAY VANEAXIAL FAN REMOVAL/INSTALLATION - continued**

**e. Remove fan (3) from fuselage (23).**

- (1) Remove remaining screws (8) and washers (9).
- (2) Remove fan (3).

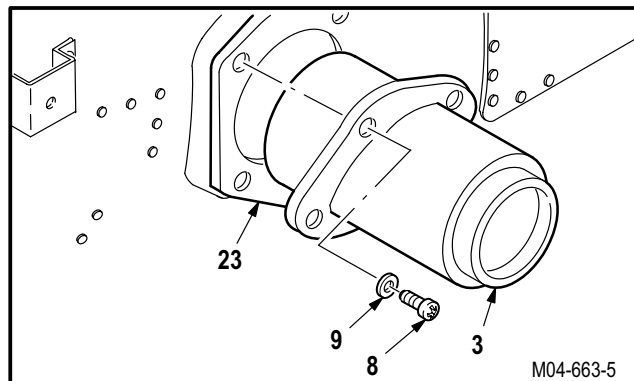

**13.30.4. Cleaning**

- a. **Clean removed and attaching parts** (para 1.47).

**13.30.5. Inspection**

- a. **Check wires for cuts and nicks** (para 13.1).
- b. **Check removed and attaching parts for nicks, dents, cracks, and stripped or damaged threads** (para 13.1).
- c. **Check removed and attaching parts for corrosion** (para 1.49).

**13.30.6. Installation**

**NOTE**

If installing the right fan, go to step a. If installing the left fan, go to step c.

**a. Install fan (3) on fuselage (23).**

- (1) Position fan (3) on fuselage (23).
- (2) Install three screws (8) and washers (9) on fan (3).

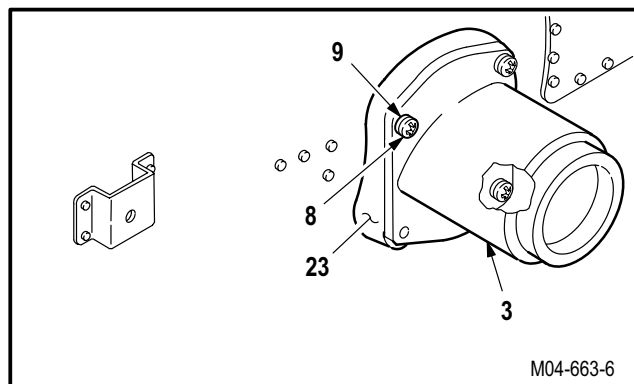

**b. Install fan wire harness (1) on bracket (2) and fan (3).**

- (1) Install clamps (6) and (10) on fan wire harness (1).
- (2) Install screw (8) through washer (9), clamp (10), and fan (1).
- (3) Install screw (4) through washer (5), clamps (6) and (7), and bracket (2).
- (4) Go to step f.

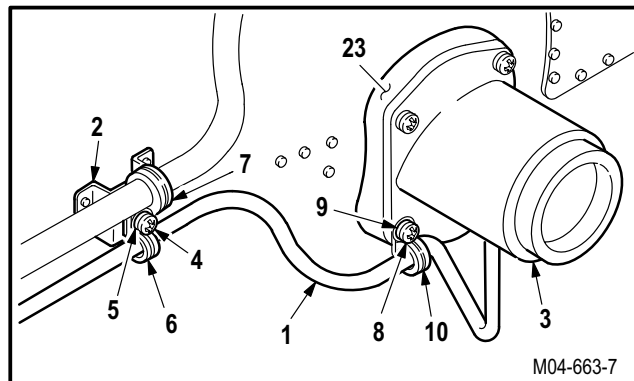

GO TO NEXT PAGE

**13.30. FORWARD AVIONICS BAY VANEAXIAL FAN REMOVAL/INSTALLATION - continued**

**c. Install fan (3) on fuselage (23).**

- (1) Position fan (3) on fuselage (23).
- (2) Install two screws (8) and washers (9) on fan (3).

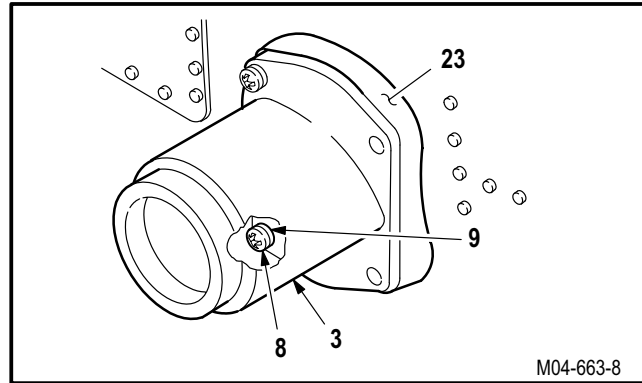

**d. Install fan wire harness (1) on bracket (11) and fan (3).**

- (1) Install clamps (16) and (18) on fan wire harness (1).
- (2) Install screw (8) through washer (9), clamp (18), and fan (3).
- (3) Install screw (12) through washer (13), clamp (14), spacer (15), clamps (16) and (17), and bracket (11).

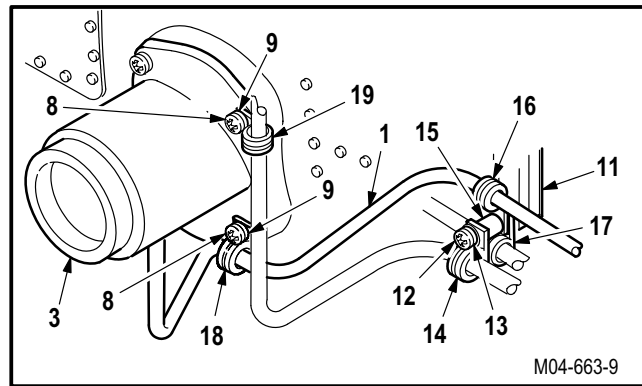

**e. Install clamp (19) on fan (3).**

- (1) Install screw (8) and washer (9).

**f. Attach fan electrical wires (20) to splices (21) on wire harness (22) (W118 left or W119 right) (TM 55-1500-323-24).**

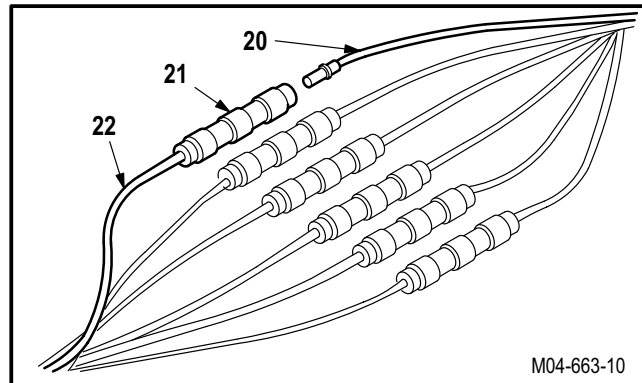

**g. Apply sealing compound to four screws (8). Use sealing compound (item 178, App F).**

**h. Install left or right forward avionics bay vaneaxial fan air duct (para 13.31).**

**i. If removed, install TB 305 track assembly (para 9.54).**

**j. Inspect (QA).**

**k. Perform ECS maintenance operational check (TM 1-1520-238-T).**

**l. Install access panel L60 or R60 (para 2.2).**

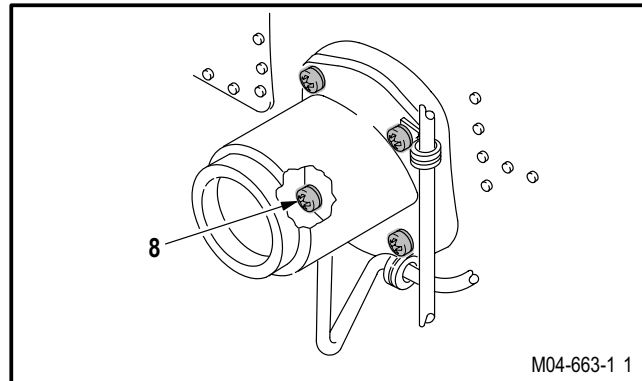

END OF TASK

**13.31. FORWARD AVIONICS BAY VANEAXIAL FAN AIR DUCT REMOVAL/INSTALLATION**

13.31.1. Description

This task covers: Removal. Cleaning. Inspection. Installation.

13.31.2. Initial Setup

**Tools:**

Aircraft mechanic's tool kit (item 376, App H)  
 0 - 30 inch-pound 1/4-inch drive dial indicator torque wrench (item 445, App H)

**References:**

TM 1-1520-238-T

**Personnel Required:**

67R Attack Helicopter Repairer  
 67R3F Attack Helicopter Repairer/Technical Inspector

**Equipment Conditions:**

<u>Ref</u>	<u>Condition</u>
1.57	Helicopter safed
2.2	Access panel L60 or R60 removed

**NOTE**

This task is typical for the left or right forward avionics bay vaneaxial fan air ducts.

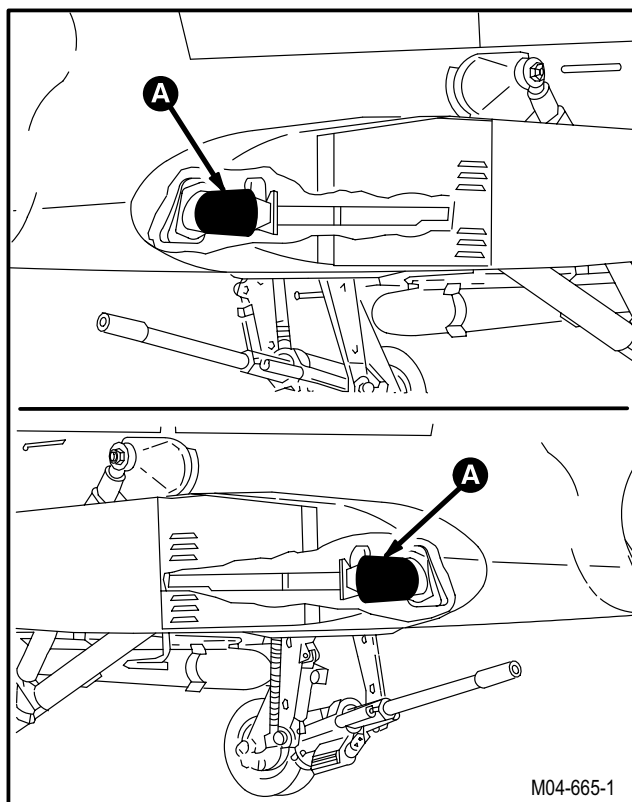

M04-665-1

GO TO NEXT PAGE

---

**13.31. FORWARD AVIONICS BAY VANEAXIAL FAN AIR DUCT REMOVAL/INSTALLATION - continued**

---

13.31.3. Removal

a. **Remove fan air duct (1) from air duct (2) and fan (3).**

(1) Remove eight bolts (4) and washers (5).

(2) Loosen clamp (6).

(3) Remove fan air duct (1), clamp (6), and ring (7).

13.31.4. Cleaning

a. **Wipe removed and attaching parts with a clean rag.**

13.31.5. Inspection

a. **Check fan and fan air duct for cracks** (para 13.1).

b. **Check removed and attaching parts for corrosion** (para 1.49).

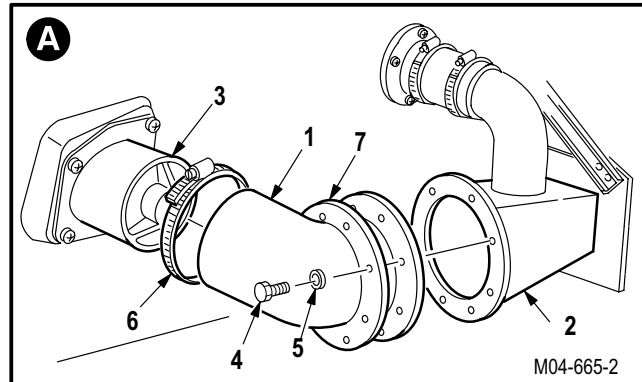

GO TO NEXT PAGE

---

**13.31. FORWARD AVIONICS BAY VANEAXIAL FAN AIR DUCT REMOVAL/INSTALLATION - continued**

---

13.31.6. Installation

- a. **Install fan air duct (1) on duct (2) and fan (3).**  
Torque eight bolts (4) to **20 INCH-POUNDS**.

- (1) Install ring (7) and clamp (6) on fan air duct (1).
- (2) Install fan air duct (1) on fan (3).
- (3) Install eight bolts (4) and washers (5) through ring (7) and fan air duct (1) into duct (2).
- (4) Tighten clamp (6) on fan air duct (1) and fan (3).
- (5) Torque eight bolts (4) to **20 INCH-POUNDS**.  
Use torque wrench.

- b. **Inspect (QA).**

- c. **Perform ECS maintenance operational check**  
(TM 1-1520-238-T).

- d. **Install access panel L60 or R60** (para 2.2).

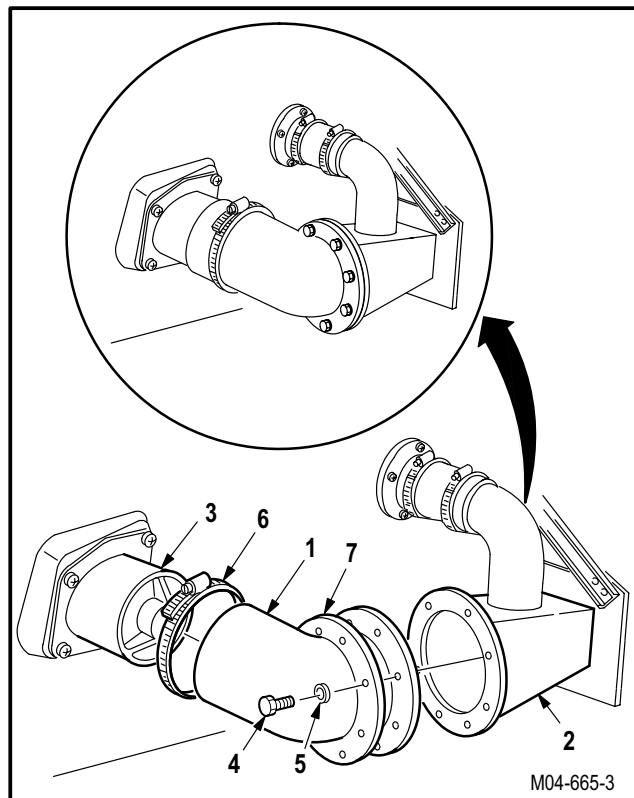

END OF TASK

---

**13.32. FORWARD AVIONICS BAY AIR COOLING DUCT ASSEMBLY  
REMOVAL/INSTALLATION**

---

13.32.1. Description

This task covers: Removal. Cleaning. Inspection. Repair. Installation.

---

13.32.2. Initial Setup

**Tools:**

Aircraft mechanic's tool kit (item 376, App H)  
 Light duty laboratory apron (item 27, App H)  
 Chemical protective gloves (item 154, App H)  
 Adjustable air filtering respirator (item 262, App H)

**References:**

TM 1-1520-238-T

**Materials/Parts:**

Gasket  
 Adhesive (item 16, App F)

**Personnel Required:**

67R Attack Helicopter Repairer  
 67R3F Attack Helicopter Repairer/Technical  
 Inspector

**Equipment Conditions:**

<u>Ref</u>	<u>Condition</u>
1.57	Helicopter safed
2.2	Access panel L60 or R60 removed

**NOTE**

This task is typical for the left or right forward avionics bay air cooling ducts.

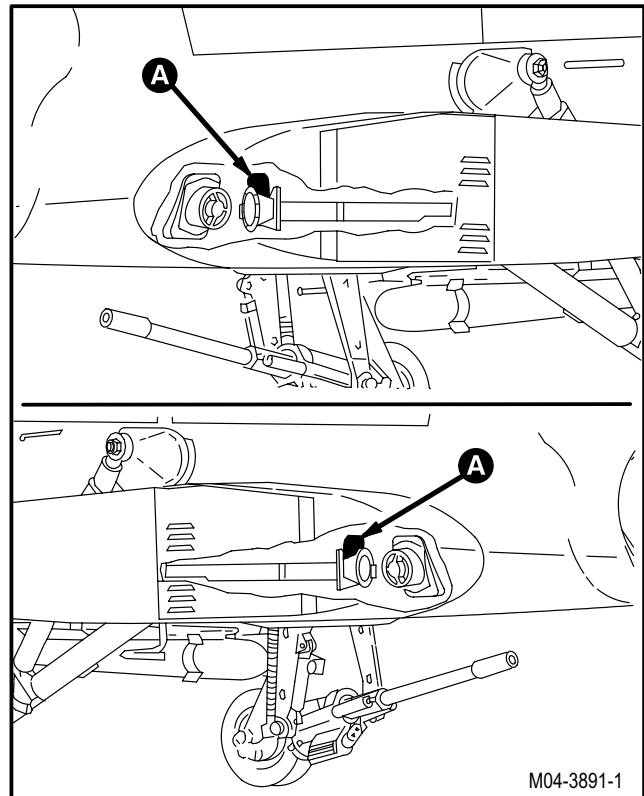

M04-3891-1

GO TO NEXT PAGE

---

**13.32. FORWARD AVIONICS BAY AIR COOLING DUCT ASSEMBLY  
REMOVAL/INSTALLATION - continued**

---

**13.32.3. Removal****a. Remove hose (1) from air ducts (2) and (3).**

- (1) Loosen two clamps (4).
- (2) Remove hose (1) and two clamps (4).

**NOTE**

Left hand duct has four screws. Right hand duct has three screws.

**b. Remove air duct (3) from fuselage (5).**

- (1) Remove screws (6) and washers (7) from air duct (3).
- (2) Remove air duct (3).

**13.32.4. Cleaning****a. Wipe removed and attaching parts with a clean rag.****13.32.5. Inspection**

- a. **Check air duct and hose for cracks** (para 13.1).
- b. **Check air duct seal for tears and gouges** (para 13.1).
- c. **Check gasket on duct for cuts or gouges.** Replace defective gasket.
- d. **Check removed and attaching parts for corrosion** (para 1.49).

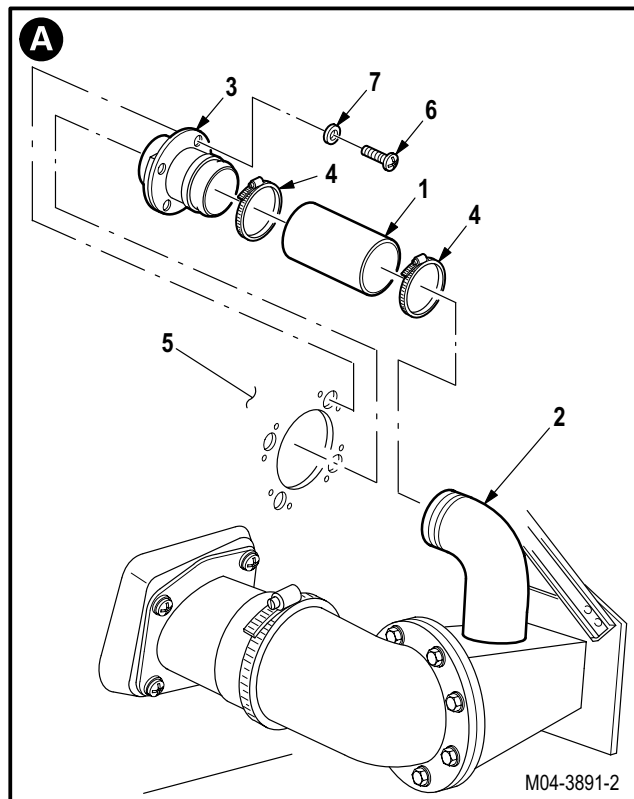

GO TO NEXT PAGE

**13.32. FORWARD AVIONICS BAY AIR COOLING DUCT ASSEMBLY  
REMOVAL/INSTALLATION - continued**

13.32.6. Repair

- a. **Remove gasket (8) from duct (3).**
- b. **Clean duct (3)** (para 1.47).

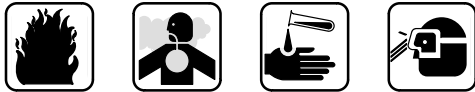

- c. **Install new gasket (8) on duct (3).**

- (1) Apply adhesive on mating surfaces of gasket (8) and duct (3). Use adhesive (item 16, App F).
- (2) Position gasket (8) on duct (3).

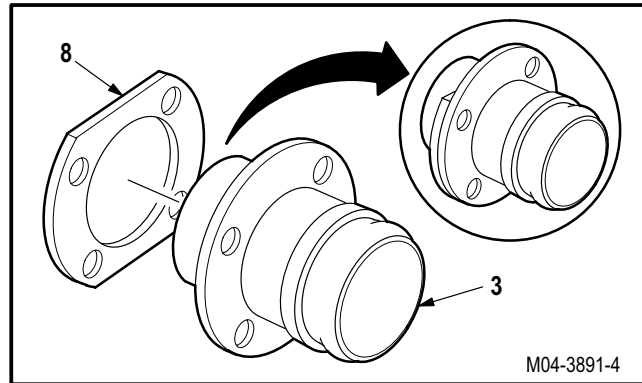

13.32.7. Installation

**NOTE**

Left hand duct has four screws. Right hand duct has three screws.

- a. **Install air duct (3) on fuselage (5).**

- (1) Position air duct (3) on fuselage (5).
- (2) Install screws (6) and washers (7).

- b. **Install hose (1) on air ducts (2) and (3).**

- (1) Install hose (1) and two clamps (4) on ducts (2) and (3).
- (2) Center hose (1) on ducts (2) and (3).
- (3) Tighten two clamps (4).

- c. **Inspect (QA).**

- d. **Perform ECS maintenance operational check** (TM 1-1520-238-T).

- e. **Install access panel L60 or R60** (para 2.2).

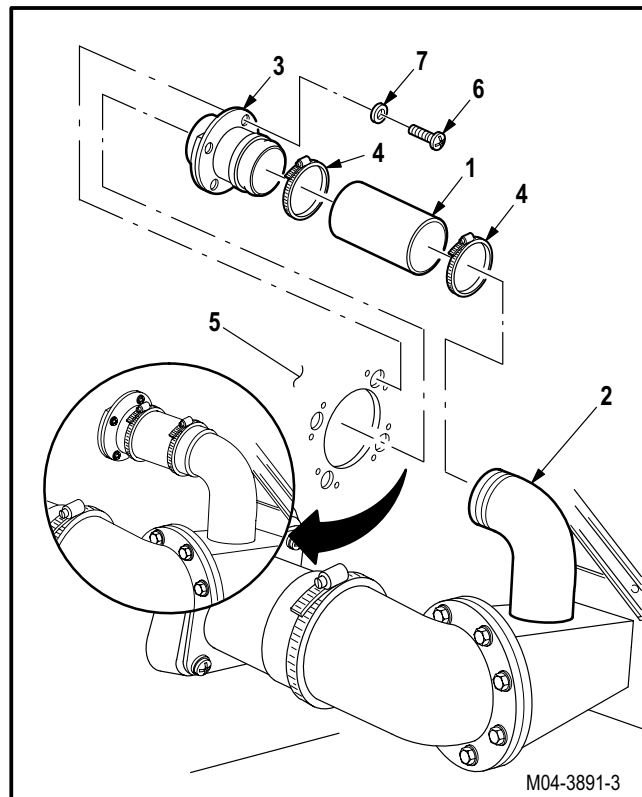

END OF TASK



**13.33. AFT VANEAXIAL FAN REMOVAL/INSTALLATION**

13.33.1. Description

This task covers: Removal. Cleaning. Inspection. Installation.

13.33.2. Initial Setup

**Tools:**

- Aircraft mechanic's tool kit (item 376, App H)
- Light duty laboratory apron (item 27, App H)
- Chemical protective gloves (item 154, App H)
- Adjustable air filtering respirator (item 262, App H)

**References:**

TM 1-1520-238-T

**Materials/Parts:**

Sealing compound (item 178, App F)

**Personnel Required:**

- 67R Attack Helicopter Repairer
- 67R3F Attack Helicopter Repairer/Technical Inspector

**Equipment Conditions:**

<u>Ref</u>	<u>Condition</u>
1.57	Helicopter safed
2.2	Access door R295 opened

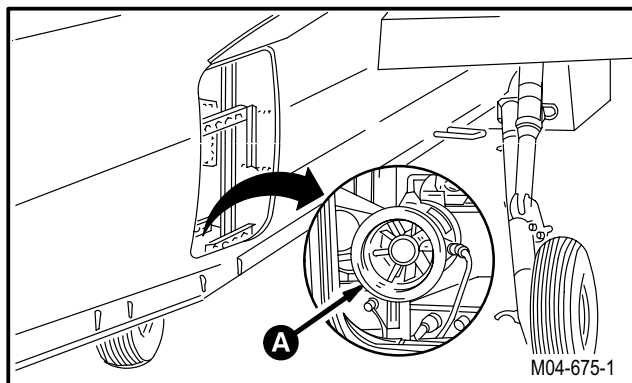

GO TO NEXT PAGE

**13.33. AFT VANEAXIAL FAN REMOVAL/INSTALLATION - continued**

13.33.3. Removal

a. **Detach connector P283 (1) from receptacle (B2)J1 (2).**

b. **Remove outlet hose (3) from fan (4).**

(1) Loosen clamp (5).

(2) Remove hose (3) and clamp (5).

c. **Remove fan (4) from support (6).**

(1) Remove sealing compound from four screws (7) and washers (8) (para 1.47).

(2) Remove four screws (7) and washers (8).

(3) Remove fan (4).

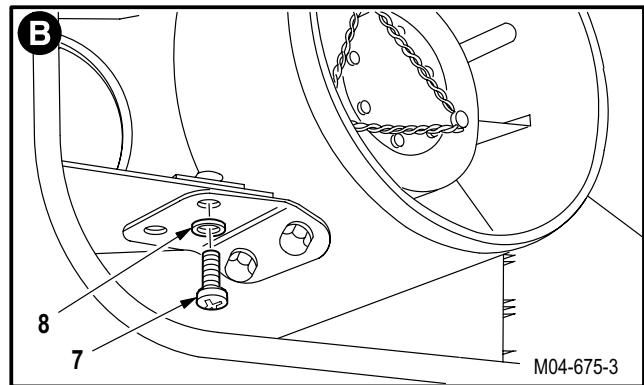
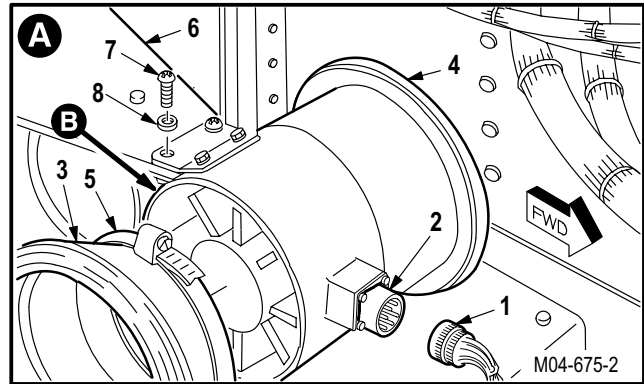

13.33.4. Cleaning

a. **Clean removed and attaching parts** (para 1.47).

13.33.5. Inspection

a. **Check fan and hose for cracks** (para 13.1).

b. **Check removed and attaching parts for corrosion** (para 1.49).

GO TO NEXT PAGE

---

**13.33. AFT VANEAXIAL FAN REMOVAL/INSTALLATION - continued**



---

13.33.6. Installation**a. Install fan (4) on support (6).**

- (1) Position fan (4) on support (6).
- (2) Install four screws (7) and washers (8).
- (3) Apply sealing compound to four screws (7) and washers (8). Use sealing compound (item 178, App F).

**b. Install outlet hose (3) and clamp (5) on fan (4).**

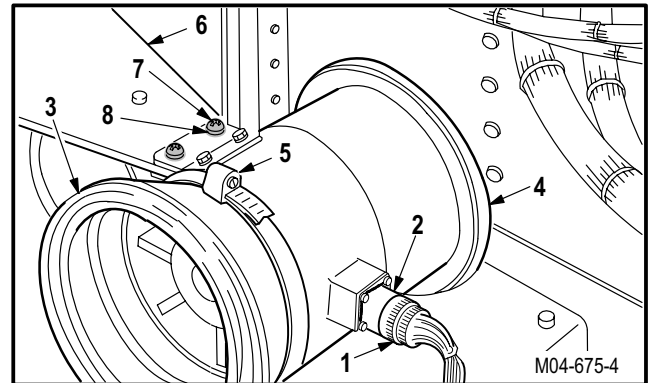
- (1) Position hose (3) and clamp (5) on fan (4).
- (2) Tighten clamp (5).

**c. Attach connector P283 (1) to receptacle (B2)J1 (2).****d. Inspect (QA).****e. Perform ECS maintenance operational check (TM 1-1520-238-T).****f. Secure access door R295 (para 2.2).**

END OF TASK

---

### 13.34. ECS PANEL REMOVAL/INSTALLATION

---

#### 13.34.1. Description

This task covers: Removal. Cleaning. Inspection. Installation.

---

#### 13.34.2. Initial Setup

##### Tools:

Electrical tool kit (item 378, App H)

##### References:

TM 1-1520-238-T  
TM 9-1090-208-23-1

##### Equipment Conditions:

<u>Ref</u>	<u>Condition</u>
1.57	Helicopter safed
TM 9-1090-208-23-1	Stores jettison panel removed; ARCS panel removed

##### Personnel Required:

68X Armament/Electrical System Repairer  
68X3F Armament/Electrical System Repairer/  
Technical Inspector

---

#### 13.34.3. Removal

- Enter pilot station** (para 1.56). **Observe all safety precautions.**
- On pilot center circuit breaker panel, open LT PRI circuit breaker.**
- On pilot aft circuit breaker panel, open ECS CAB circuit breaker.**

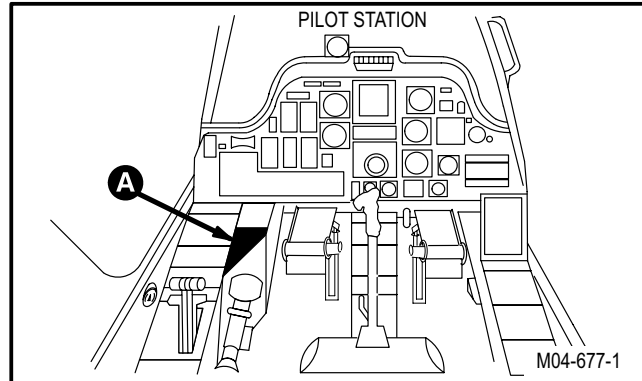

GO TO NEXT PAGE

**13.34. ECS PANEL REMOVAL/INSTALLATION - continued**

**d. Remove ECS panel (1) from console (2).**

- (1) Unlock three fasteners (3).
- (2) Remove panel (1).

**e. Detach connector (A139)P1 (4) from receptacle J177 (5).**

13.34.4. Cleaning

- a. **Wipe removed and attaching parts with a clean rag.**

13.34.5. Inspection

- a. **Check panel for cracks** (para 13.1).
- b. **Check removed and attaching parts for corrosion** (para 1.49).

13.34.6. Installation

- a. **Attach connector (A139)P1 (4) to receptacle J177 (5).**
- b. **Install panel (1) on console (2).**
  - (1) Position panel (1) on console (2).
  - (2) Lock three fasteners (3).
- c. **Inspect (QA).**
- d. **Install ARCS panel** (TM 9-1090-208-23-1).
- e. **Install stores jettison panel** (TM 9-1090-208-23-1).
- f. **Perform ECS maintenance operational check** (TM 1-1520-238-T).

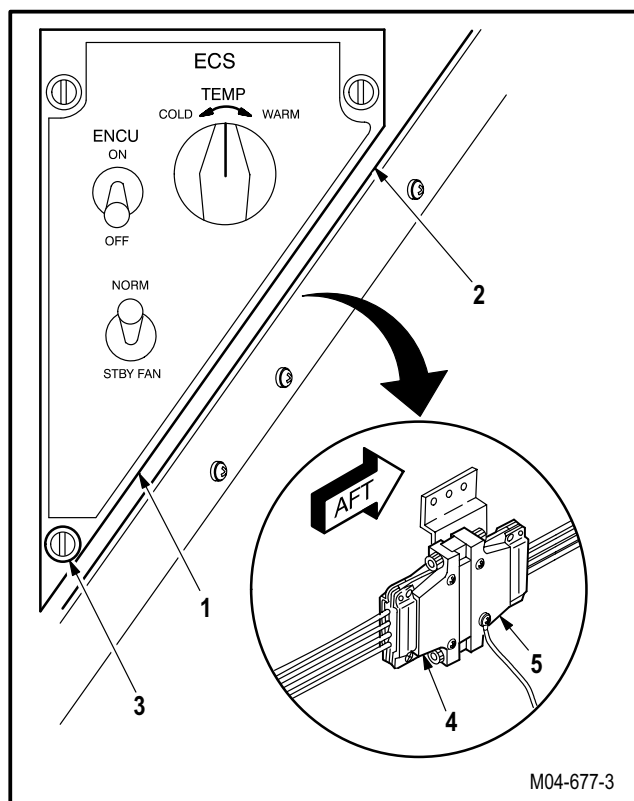
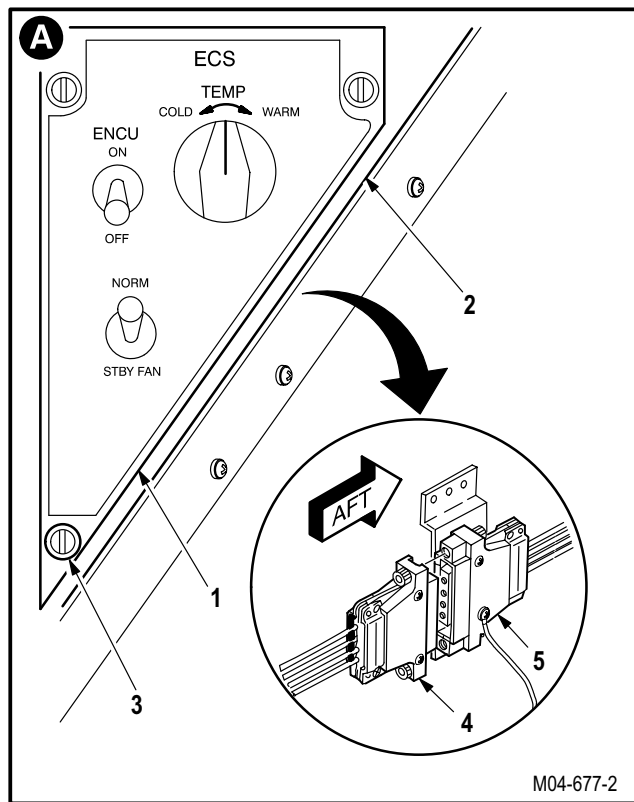

END OF TASK

---

### 13.35. ECS PANEL LIGHT INDICATING PANEL REMOVAL/INSTALLATION

---

#### 13.35.1. Description

This task covers: Removal. Cleaning. Inspection. Installation.

---

#### 13.35.2. Initial Setup

##### **Tools:**

Electrical tool kit (item 378, App H)

##### **References:**

TM 1-1520-238-T

##### **Personnel Required:**

68X Armament/Electrical System Repairer  
68X3F Armament/Electrical System Repairer/  
Technical Inspector

##### **Equipment Conditions:**

<u>Ref</u>	<u>Condition</u>
1.57	Helicopter safed

---

#### **NOTE**

This task can be performed on helicopter or off helicopter.

#### 13.35.3. Removal

- a. **Enter pilot station** (para 1.56). **Observe all safety precautions.**

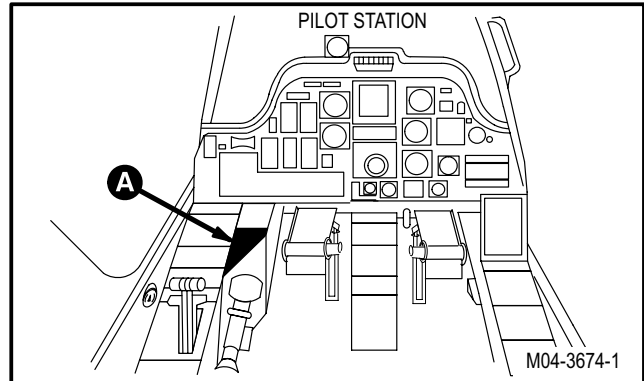

GO TO NEXT PAGE

### 13.35. ECS PANEL LIGHT INDICATING PANEL REMOVAL/INSTALLATION - continued

b. **Remove knob (1) from variable resistor shaft (2).**

- (1) Loosen two screws (3).
- (2) Remove knob (1).

c. **Remove indicating panel (4) from support panel (5).**

- (1) Remove three screws (6).
- (2) Remove panel (4).

#### 13.35.4. Cleaning

a. **Wipe removed and attaching parts with a clean rag.**

#### 13.35.5. Inspection

- a. **Check panel for nicks, dents, or cracks** (para 13.1).
- b. **Check removed and attaching parts for corrosion** (para 1.49).

#### 13.35.6. Installation

a. **Install panel (4) on panel (5).**

- (1) Position panel (4) on panel (5).
- (2) Install three screws (6).

b. **Install knob (1) on shaft (2).**

- (1) Tighten two screws (3).

c. **Inspect (QA).**

d. **Perform pilot edge-lights maintenance operational check** (TM 1-1520-238-T).

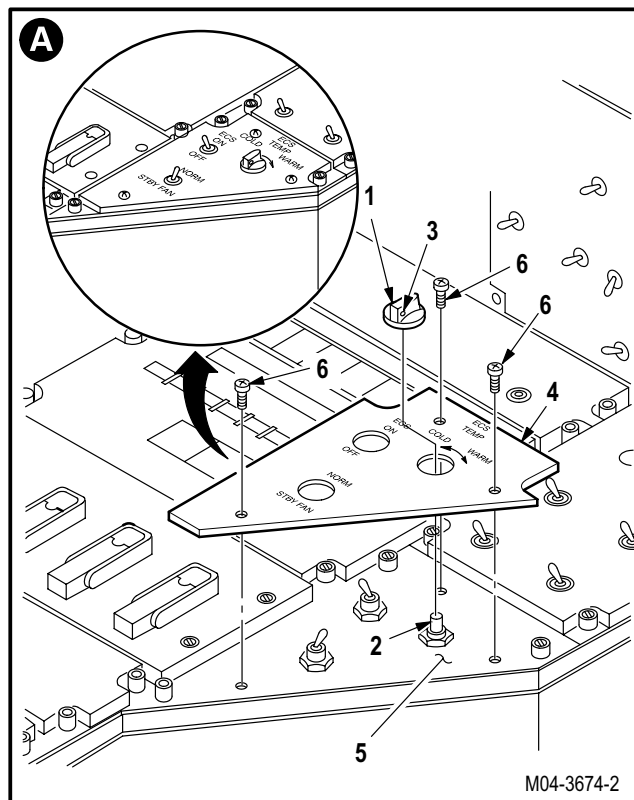

END OF TASK

---

**13.36. ECS PANEL RESISTOR ASSEMBLY REMOVAL/INSTALLATION (AVIM)**

---

13.36.1. Description

This task covers: Removal. Cleaning. Inspection. Installation.

---

13.36.2. Initial Setup

**Tools:**

Electrical tool kit (item 378, App H)  
Light duty laboratory apron (item 27, App H)  
Chemical protective gloves (item 154, App H)  
Adjustable air filtering respirator (item 262, App H)  
Soldering gun (item 334, App H)

**Personnel Required:**

68X Armament/Electrical System Repairer  
68X3F Armament/Electrical System Repairer/  
Technical Inspector

**Materials/Parts:**

Solder (item 189, App F)

**References:**

TM 55-1500-323-24

---

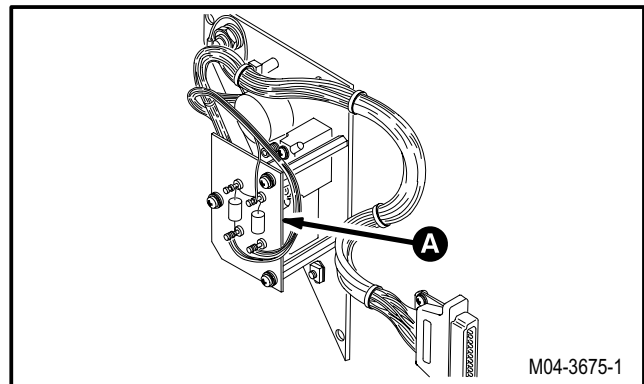

GO TO NEXT PAGE



---

**13.36. ECS PANEL RESISTOR ASSEMBLY REMOVAL/INSTALLATION (AVIM) - continued**

---



**WARNING**

**Soldering gun can cause severe burns to personnel and start fires. Observe all safety precautions when using soldering gun. If injury occurs, seek medical aid.**

**13.36.3. Removal**
**a. Desolder wires (1) from resistor assembly (2).**

(1) Identify and desolder wires (1) from terminals (3). Use soldering gun (TM 55-1500-323-24).

**b. Remove resistor assembly (2) from three posts (4).**

(1) Remove three screws (5), lockwashers (6), and washers (7) from resistor assembly (2).

(2) Remove resistor assembly (2).

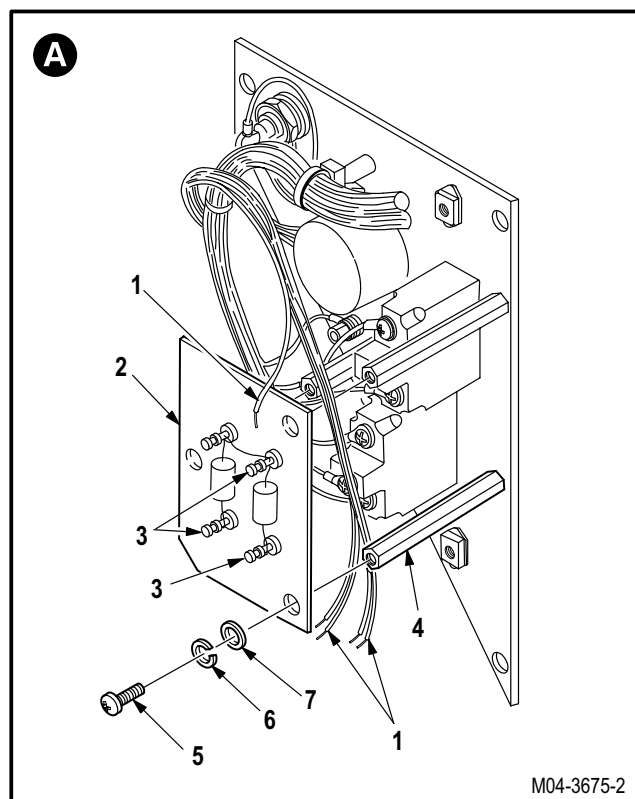
**13.36.4. Cleaning**
**a. Clean removed and attaching parts (para 1.47).**
**13.36.5. Inspection**
**a. Check switches for cracks, loose terminals, and signs of overheating (para 13.1).**
**b. Check removed and attaching parts for corrosion (para 1.49).**

GO TO NEXT PAGE

**13.36. ECS PANEL RESISTOR ASSEMBLY REMOVAL/INSTALLATION (AVIM) - continued**

13.36.6. Installation

**a. Install resistor assembly (2) on three posts (4).**

- (1) Position resistor assembly (2) on three posts (4).
- (2) Install three screws (5) through lockwashers (6), washers (7), and resistor assembly (2) into posts (4).



**WARNING**

**Soldering gun can cause severe burns to personnel and start fires. Observe all safety precautions when using soldering gun. If injury occurs, seek medical aid.**

**b. Solder wires (1) to resistor assembly (2).**

- (1) Solder identified wires (1) to terminals (3). Use soldering gun and solder (item 189, App F) (TM 55-1500-323-24).

**c. Inspect (QA).**

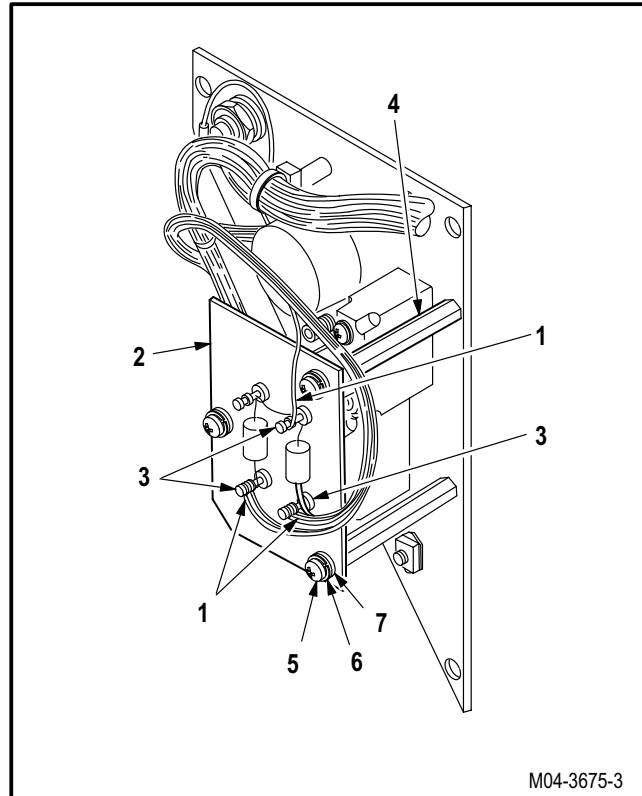

END OF TASK

---

**13.37. ECS PANEL VARIABLE RESISTOR REPLACEMENT (AVIM)**

---

13.37.1. Description

This task covers: Removal. Cleaning. Inspection. Installation.

---

13.37.2. Initial Setup**Tools:**

Electrical tool kit (item 378, App H)  
 Light duty laboratory apron (item 27, App H)  
 Chemical protective gloves (item 154, App H)  
 Adjustable air filtering respirator (item 262, App H)  
 Soldering gun (item 334, App H)

**Materials/Parts:**

Solder (item 189, App F)

**Personnel Required:**

68X Armament/Electrical System Repairer  
 68X3F Armament/Electrical System Repairer/  
 Technical Inspector

**References:**

TM 55-1500-323-24

**Equipment Conditions:**

<u>Ref</u>	<u>Condition</u>
13.35	ECS panel light indicating panel removed

---

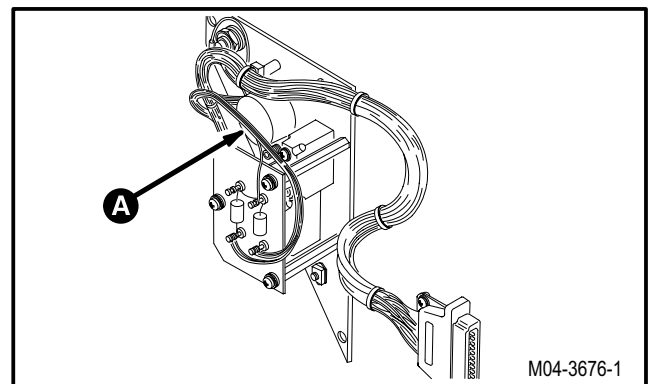

GO TO NEXT PAGE

13.37. ECS PANEL VARIABLE RESISTOR REPLACEMENT (AVIM) - continued



**WARNING**

**Soldering gun can cause severe burns to personnel and start fires. Observe all safety precautions when using soldering gun. If injury occurs, seek medical aid.**

13.37.3. Removal

a. **Desolder wires (1) from variable resistor (2).**

(1) Identify and desolder wires (1) from terminals (3). Use soldering gun (TM 55-1500-323-24).

b. **Remove variable resistor (2) from support panel (4).**

(1) Remove nut (5) and lockwasher (6) from variable resistor (2).

(2) Remove and discard variable resistor (2).

13.37.4. Cleaning

a. **Clean removed and attaching parts** (para 1.47).

13.37.5. Inspection

a. **Check switches for cracks, loose terminals, and signs of overheating** (para 13.1).

b. **Check removed and attaching parts for corrosion** (para 1.49).

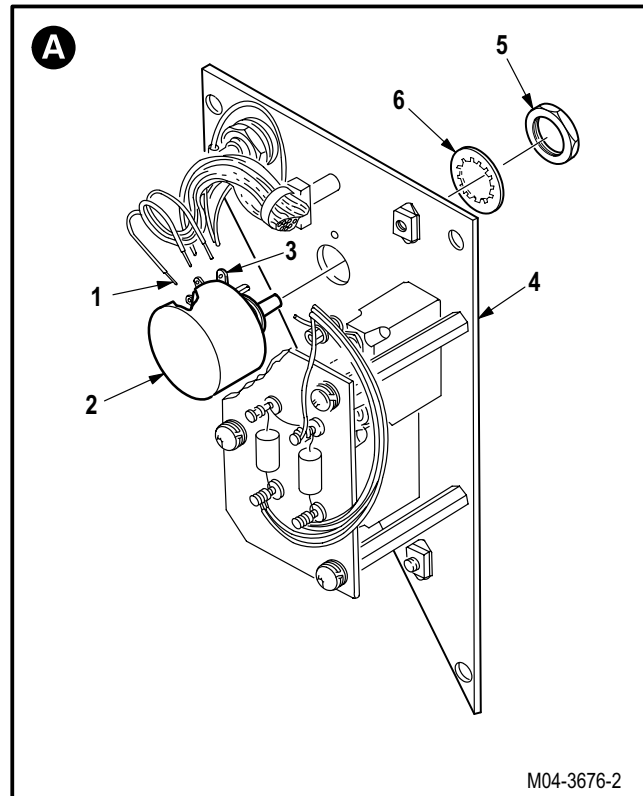

M04-3676-2

GO TO NEXT PAGE

### 13.37. ECS PANEL VARIABLE RESISTOR REPLACEMENT (AVIM) - continued

#### 13.37.6. Installation

##### a. Install new variable resistor (2) on panel (4).

- (1) Install variable resistor (2) on panel (4) so tab (7) seats in locator hole (8).
- (2) Install lockwasher (6) and nut (5) on variable resistor (2).



**Soldering gun can cause severe burns to personnel and start fires. Observe all safety precautions when using soldering gun. If injury occurs, seek medical aid.**

##### b. Solder wires (1) to variable resistor (2).

- (1) Solder identified wires (1) to terminals (3). Use soldering gun and solder (item 189, App F) (TM 55-1500-323-24).

##### c. Inspect (QA).

##### d. Install ECS panel light indicating panel (para 13.35).

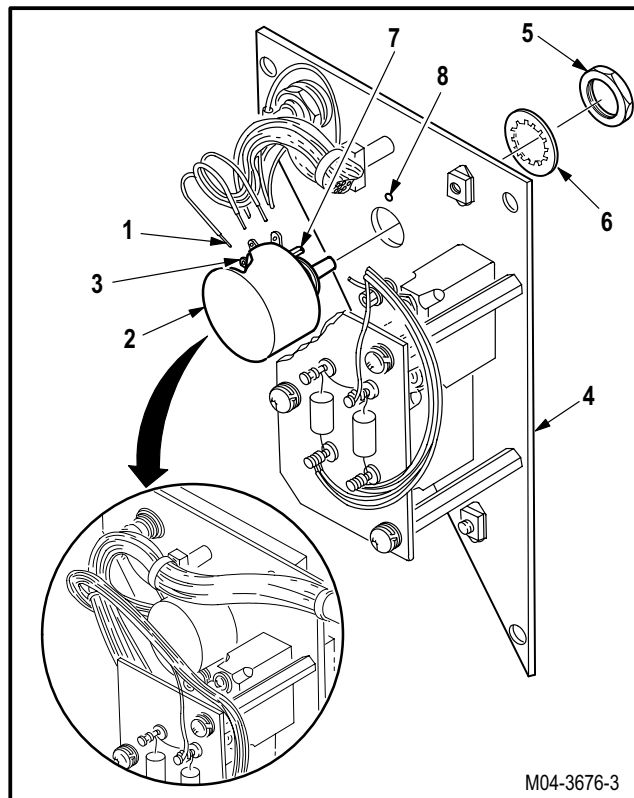

END OF TASK

**13.38. ECS PANEL TOGGLE SWITCH REPLACEMENT (AVIM)**

13.38.1. Description

This task covers: Removal. Cleaning. Inspection. Installation.

13.38.2. Initial Setup

**Tools:**

Electrical tool kit (item 378, App H)

**References:**

TM 55-1500-323-24

**Personnel Required:**

68X Armament/Electrical System Repairer  
 68X3F Armament/Electrical System Repairer/  
 Technical Inspector

**Equipment Conditions:**

<u>Ref</u>	<u>Condition</u>
13.35	ECS panel light indicating panel removed

**NOTE**

This task is typical for either toggle switch on the ECS panel. The switches differ in number and placement of wires.

13.38.3. Removal

a. **Remove resistor assembly (1) from three posts (2).**

- (1) Remove three screws (3), lockwashers (4), and washers (5) from resistor assembly (1).
- (2) Remove resistor assembly (1).

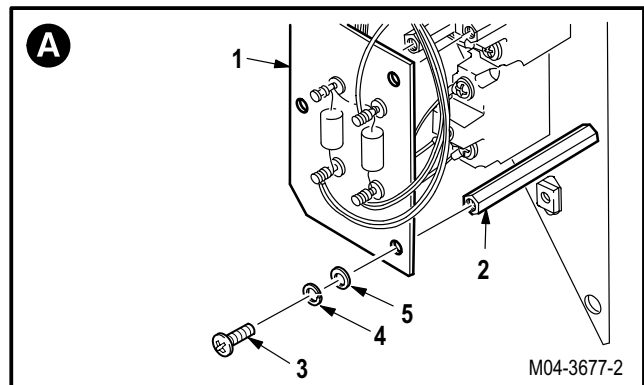
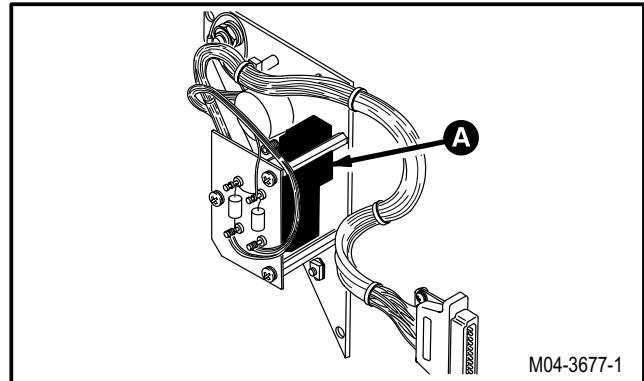

GO TO NEXT PAGE

**13.38. ECS PANEL TOGGLE SWITCH REPLACEMENT (AVIM) - continued**

**b. Detach wires (6) from toggle switch (7).**

- (1) Identify wires (6).
- (2) Remove screws (8), lockwashers (9), and terminal lugs (10) from switch (7).

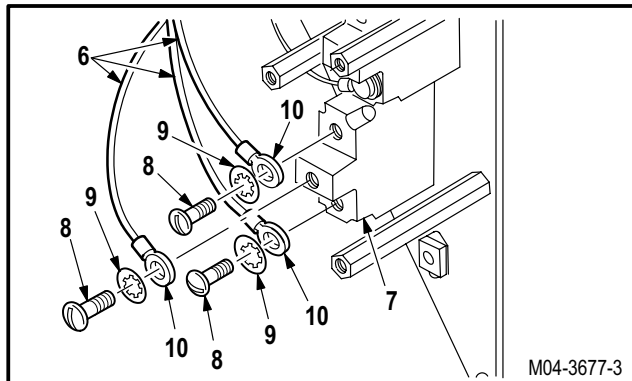

**c. Remove switch (7) from support panel (11).**

- (1) Remove nut (12) from switch (7).
- (2) Remove switch (7), lockring (13), lockwasher (14), and nut (15) from panel (11).
- (3) Discard switch (7).

**13.38.4. Cleaning**

- a. **Wipe removed and attaching parts with a clean rag.**

**13.38.5. Inspection**

- a. **Check switches for cracks, loose terminals, and signs of overheating** (para 13.1).
- b. **Check removed and attaching parts for corrosion** (para 1.49).

**13.38.6. Installation**

**a. Install new switch (7) on panel (11).**

- (1) Install nut (15), lockwasher (14), and lockring (13) on switch (7).
- (2) Install switch (7) on panel (11) so tab (16) seats in locator hole (17).
- (3) Install nut (12) finger tight on switch (7).
- (4) Adjust nut (15) so 1.5 to 2 threads of switch (7) will be exposed above nut (12).
- (5) Tighten nut (12) on switch (7).

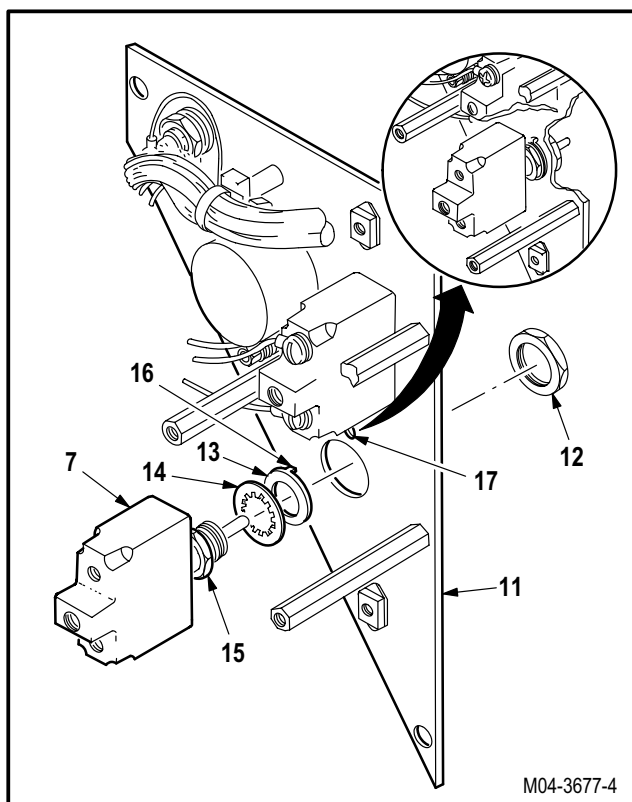

GO TO NEXT PAGE

**13.38. ECS PANEL TOGGLE SWITCH REPLACEMENT (AVIM) - continued**

**b. Attach identified wires (6) to switch (7).**

- (1) Position three terminal lugs (10) on switch (7).
- (2) Install three screws (8) and lockwashers (9).

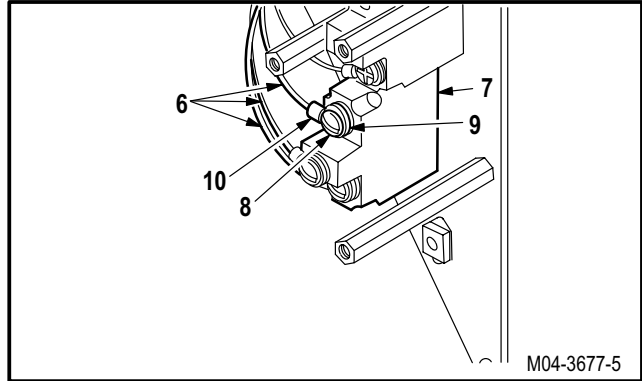

**c. Install resistor assembly (1) on three posts (2).**

- (1) Position resistor assembly (1) on posts (2).
- (2) Install three screws (3) through lockwashers (4), washers (5), and resistor assembly (1) into posts (2).

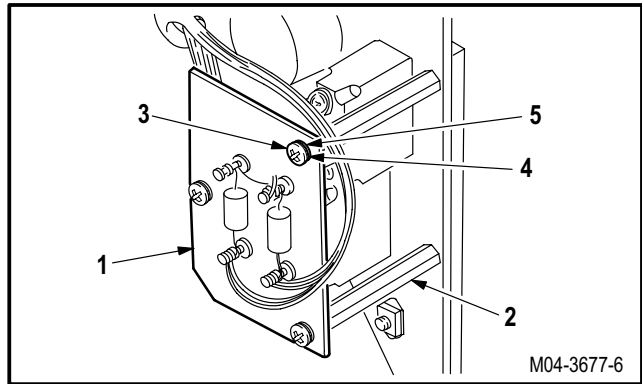

**d. Inspect (QA).**

**e. Install ECS panel light indicating panel (para 13.35).**

END OF TASK



---

**13.39. ECS PANEL RECEPTACLE REPLACEMENT (AVIM)**

---

13.39.1. Description

This task covers: Removal. Cleaning. Inspection. Installation.

---

13.39.2. Initial Setup

**Tools:**

Electrical tool kit (item 378, App H)

**Personnel Required:**

68X Armament/Electrical System Repairer  
 68X3F Armament/Electrical System Repairer/  
 Technical Inspector

**Equipment Conditions:**

<u>Ref</u>	<u>Condition</u>
13.35	ECS panel light indicating panel removed

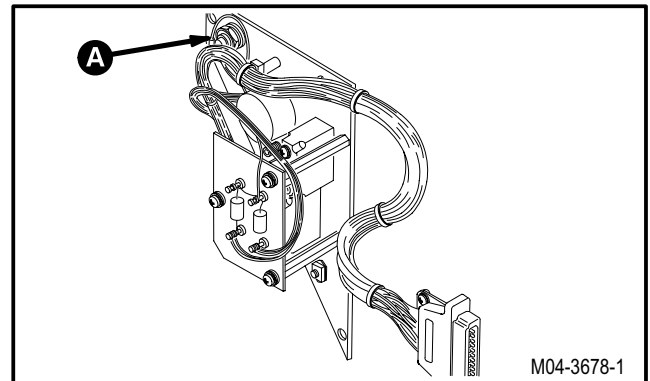

GO TO NEXT PAGE

**13.39. ECS PANEL RECEPTACLE REPLACEMENT (AVIM) - continued**

13.39.3. Removal

a. **Detach wire (1) from terminal (2).**

(1) Remove screw (3), lockwasher (4), and terminal lug (5).

b. **Remove receptacle (6) from support panel (7).**

(1) Remove nut (8) and lockwasher (9).

(2) Remove receptacle (6) and terminal lug (10).

13.39.4. Cleaning

a. **Wipe removed and attaching parts with a clean rag.**

13.39.5. Inspection

a. **Check switches for cracks, loose terminals, and signs of overheating** (para 13.1).

b. **Check removed and attaching parts for corrosion** (para 1.49).

13.39.6. Installation

a. **Install receptacle (6) on panel (7).**

(1) Position receptacle (6) on panel (7).

(2) Install terminal lug (10), lockwasher (9), and nut (8).

b. **Attach wire (1) to terminal (2).**

(1) Position terminal lug (5) on terminal (2).

(2) Install screw (3) and lockwasher (4).

c. **Inspect (QA).**

d. **Install ECS panel light indicating panel** (para 13.35).

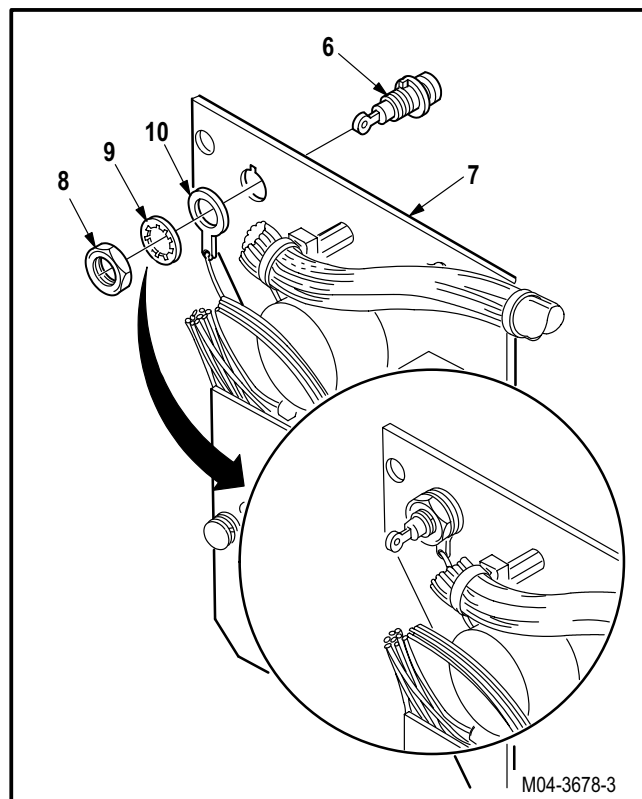
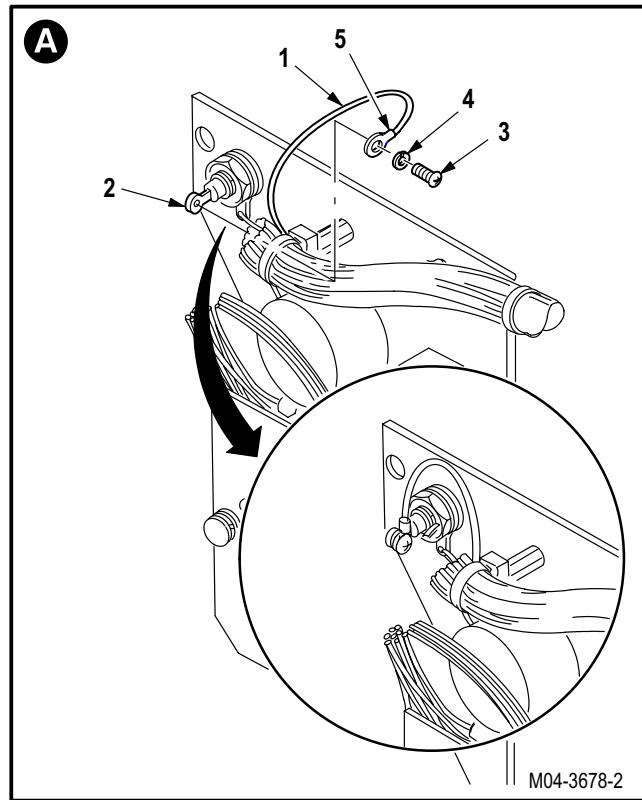

END OF TASK

**13.40. ECS SUPPORT PANEL REMOVAL/INSTALLATION (AVIM)**

13.40.1. Description

This task covers: Removal. Cleaning. Inspection. Repair. Installation.

13.40.2. Initial Setup

**Tools:**

- Electrical tool kit (item 378, App H)
- Light duty laboratory apron (item 27, App H)
- Chemical protective gloves (item 154, App H)
- Adjustable air filtering respirator (item 262, App H)

**References:**

TM 1-1500-204-23

**Personnel Required:**

- 68X Armament/Electrical System Repairer
- 68X3F Armament/Electrical System Repairer/  
Technical Inspector

**Equipment Conditions:**

<u>Ref</u>	<u>Condition</u>
13.35	ECS panel light indicating panel removed
13.36	ECS panel resistor assembly removed
13.37	ECS panel variable resistor removed
13.38	ECS panel toggle switches removed
13.39	ECS panel receptacle removed

**Materials/Parts:**

- Sealing compound primer (item 146, App F)
- Sealing compound (item 167, App F)
- Strap (item 193, App F)

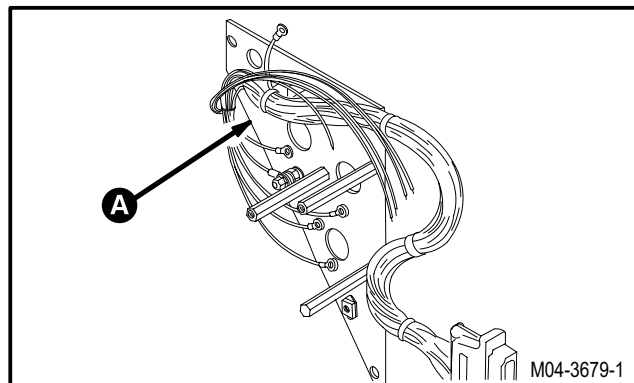

GO TO NEXT PAGE

**13.40. ECS SUPPORT PANEL REMOVAL/INSTALLATION (AVIM) - continued**

13.40.3. Removal

a. **Remove wire (1) from screw (2).**

- (1) Hold screw (2).
- (2) Remove nut (3), washer (4) and terminal lug (5).

b. **Remove screw (2) from support panel (6).**

- (1) Hold screw (2).
- (2) Remove nut (7), lockwasher (8), and washer (9).

c. **Remove wire harness (10) from tiedown mounting base (11).**

- (1) Cut tiedown strap (12).

d. **Remove tiedown mounting base (11) and post (13) from panel (6).**

- (1) Hold post (13). Remove screw (14).

e. **Remove tiedown base (11) from post (13).**

- (1) Hold post (13). Remove screw (15).

f. **Remove three posts (16) from panel (6).**

- (1) Hold three posts (16).
- (2) Remove three screws (17).

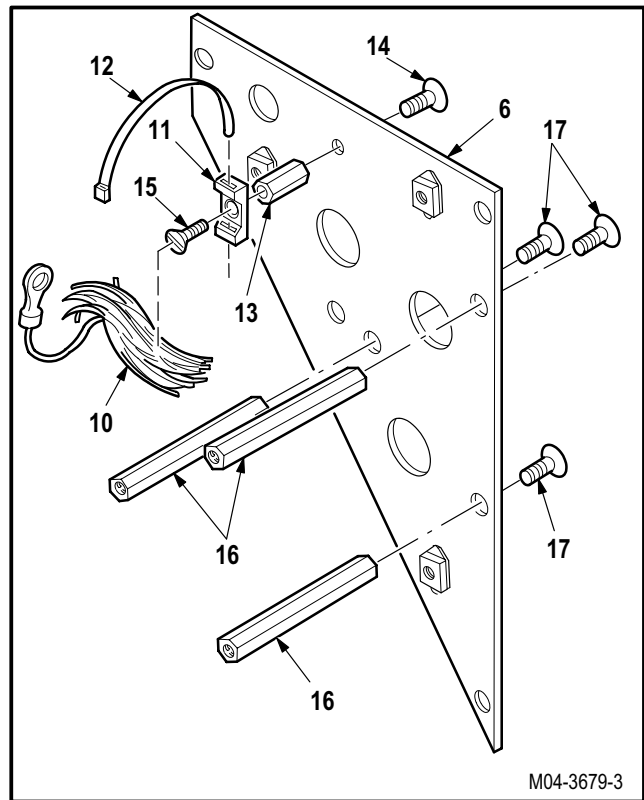
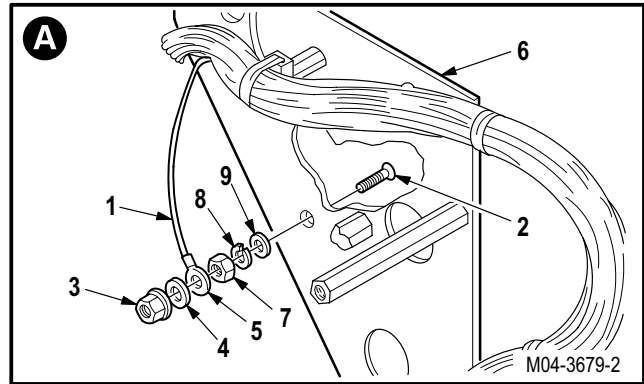

13.40.4. Cleaning

a. **Clean removed and attaching parts** (para 1.47).

13.40.5. Inspection

a. **Check panel for nicks, dents, or cracks** (para 13.1).

b. **Check removed and attaching parts for corrosion** (para 1.49).

GO TO NEXT PAGE

---

**13.40. ECS SUPPORT PANEL REMOVAL/INSTALLATION (AVIM) - continued**

---

13.40.6. Repair

- a. **Replace defective nutplates and/or turn lock fasteners on ECS support panel** (TM 1-1500-204-23).

13.40.7. Installationa. **Install three posts (16) on panel (6).**

- (1) Apply primer to three screws (17). Allow primer to dry **0.5 HOUR** at 70 °F. Use sealing compound primer (item 146, App F).
- (2) Apply sealing compound to three screws (17). Use sealing compound (item 167, App F).
- (3) Aline and hold three posts (16).
- (4) Install three screws (17).
- (5) Allow sealing compound to dry **2 HOURS** at 70 °F.

b. **Install base (11) on post (13).**

- (1) Hold post (13). Install screw (15) and base (11).

c. **Install base (11) and post (13) on ECS support panel (6).**

- (1) Hold post (13). Install screw (14).

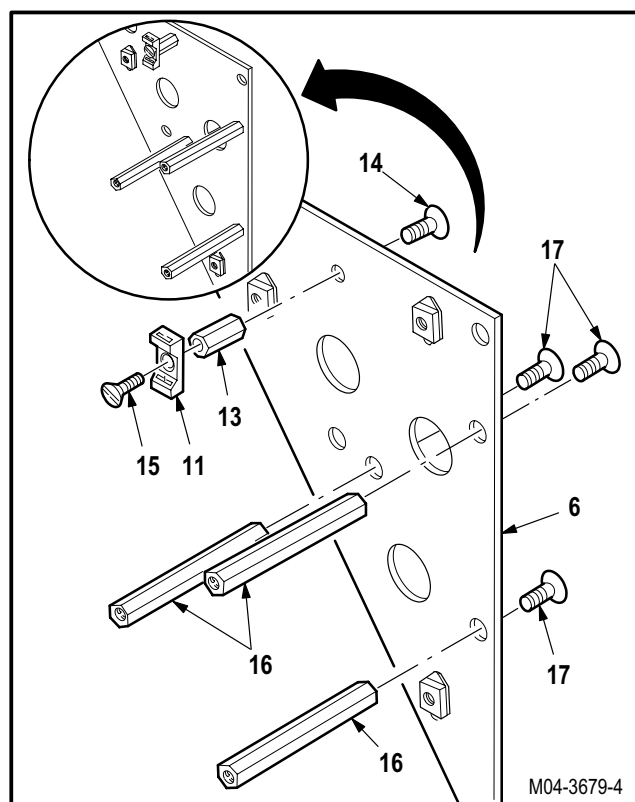

GO TO NEXT PAGE

**13.40. ECS SUPPORT PANEL REMOVAL/INSTALLATION (AVIM) - continued**

**d. Install screw (2) on panel (6).**

- (1) Install and hold screw (2).
- (2) Install washer (9), lockwasher (8), and nut (7).

**e. Install wire (1) on screw (2).**

- (1) Hold screw (2).
- (2) Install terminal lug (5), washer (4), and nut (3).

**f. Install wire harness (10) on tiedown base (11).**

- (1) Position harness (10) on tiedown base (11).
- (2) Install new tiedown strap (12). Use strap (item 193, App F).

**g. Inspect (QA).**

**h. Install ECS panel receptacle (para 13.39).**

**i. Install ECS panel toggle switches (para 13.38).**

**j. Install ECS panel variable resistor (para 13.37).**

**k. Install ECS panel resistor assembly (para 13.36).**

**l. Install ECS panel light indicating panel (para 13.35).**

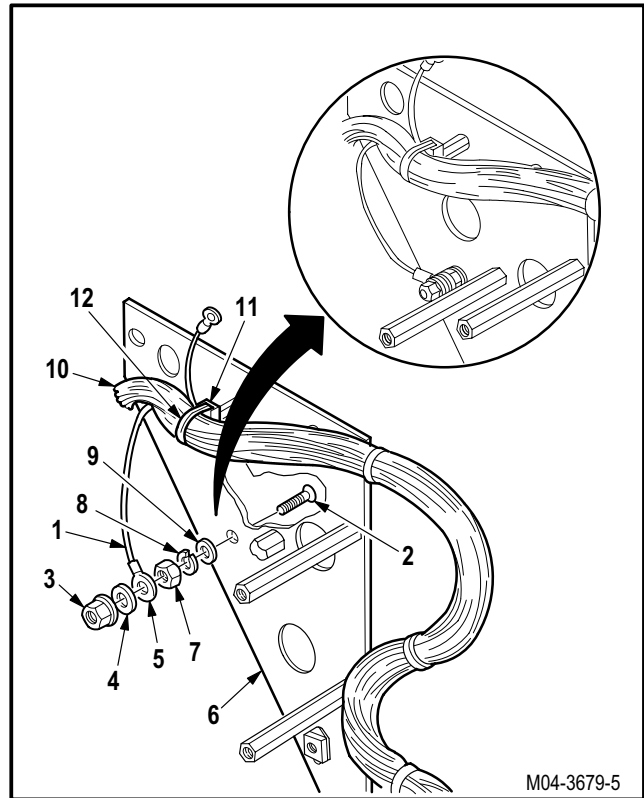

END OF TASK

**13.41. ECS FORWARD AVIONICS BAY THERMOSTATIC SWITCH REPLACEMENT**

13.41.1. Description

This task covers: Removal. Cleaning. Inspection. Installation.

13.41.2. Initial Setup

**Tools:**

- Electrical tool kit (item 378, App H)
- Light duty laboratory apron (item 27, App H)
- Chemical protective gloves (item 154, App H)
- Electric gun type heater (item 163, App H)
- Adjustable air filtering respirator (item 262, App H)
- Soldering gun (item 334, App H)

**References:**

- TM 1-1520-238-T
- TM 55-1500-323-24

**Materials/Parts:**

- Insulation sleeving (item 105, App F)
- Solder (item 189, App F)

**Personnel Required:**

- 68X Armament/Electrical System Repairer
- 68X3F Armament/Electrical System Repairer/  
Technical Inspector

**Equipment Conditions:**

<u>Ref</u>	<u>Condition</u>
1.57	Helicopter safed
2.2	Access fairing L60 or R60 removed

**NOTE**

This task is typical for ECS thermostatic switches S27, S29, S30, and S31.

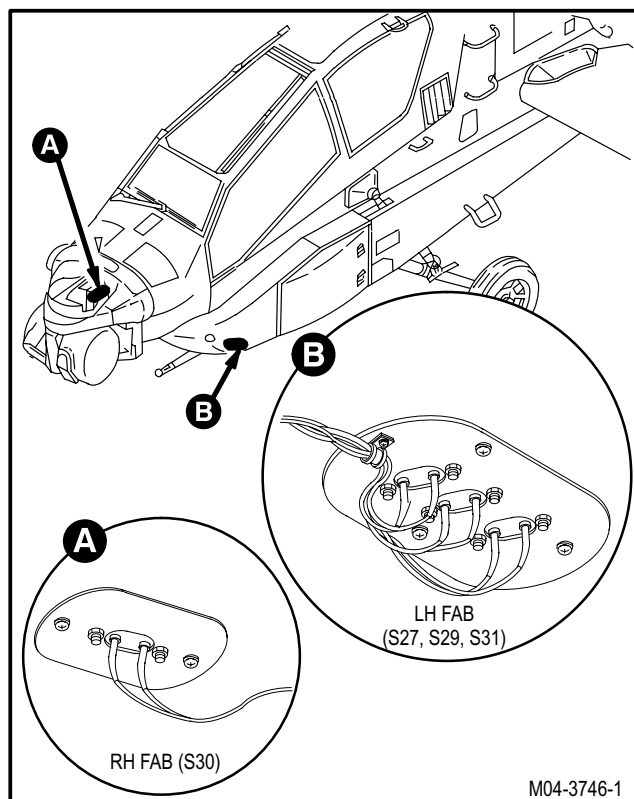

GO TO NEXT PAGE

13.41. ECS FORWARD AVIONICS BAY THERMOSTATIC SWITCH REPLACEMENT - continued

13.41.3. Removal



**WARNING**

**Soldering gun can cause severe burns to personnel and start fires. Observe all safety precautions when using soldering gun. If injury occurs, seek medical aid.**

a. **Desolder two wires (1) from thermostatic switch (2).**

- (1) Identify two wires (1).
- (2) Remove sleeving (3) from terminals (4).
- (3) Desolder two wires (1) from terminals (4). Use soldering gun (TM 55-1500-323-24).

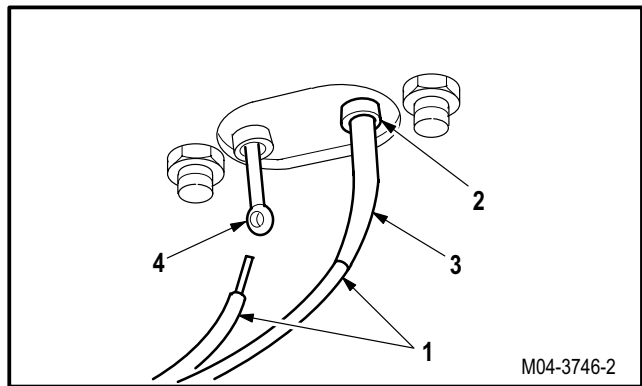

b. **Remove thermal switch cover (5) from air duct (6).**

- (1) Remove four screws (7) and washers (8) from cover (5) and clamp (9).
- (2) Remove cover (5).

c. **Remove switch (2) from cover (5).**

- (1) Hold two nuts (10).
- (2) Remove two screws (11), four washers (12), and two nuts (10).
- (3) Remove and discard switch (2).

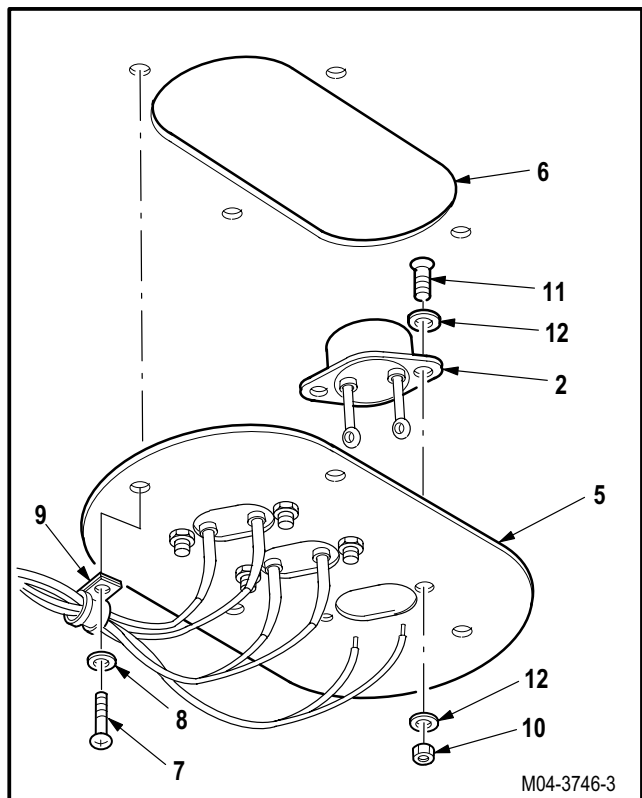

GO TO NEXT PAGE



---

**13.41. ECS FORWARD AVIONICS BAY THERMOSTATIC SWITCH REPLACEMENT - continued**

---

13.41.4. Cleaning

- a. **Clean removed and attaching parts** (para 1.47).

13.41.5. Inspection

- a. **Check wires for cuts, nicks, fraying, or chafing** (para 13.1).
- b. **Check duct and cover for cracks** (para 13.1).
- c. **Check screws and nuts for stripped or damaged threads** (para 13.1).
- d. **Check removed and attaching parts for corrosion** (para 1.49).

13.41.6. Installationa. **Install new switch (2) on cover (5).**

- (1) Position switch (2) on cover (5).
- (2) Install two screws (11) and washers (12) through switch (2) and cover (5).
- (3) Install two washers (12) and nuts (10).

b. **Install cover (5) on duct (6).**

- (1) Position cover (5) on duct (6).
- (2) Install three screws (7) and washers (8) on cover (5).
- (3) Install screw (7) through washer (8), clamp (9), and cover (5) into duct (6).

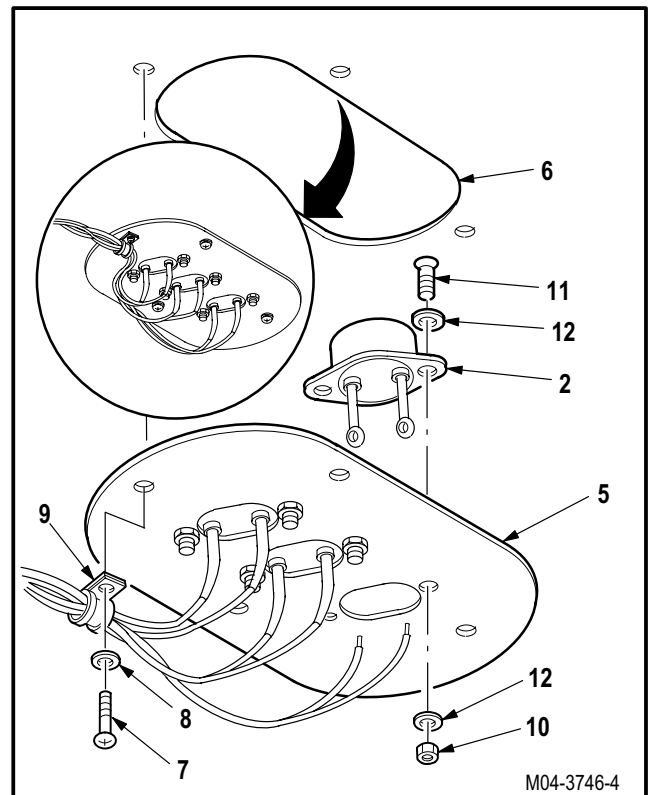

GO TO NEXT PAGE

13.41. ECS FORWARD AVIONICS BAY THERMOSTATIC SWITCH REPLACEMENT - continued



**WARNING**

- Soldering gun can cause severe burns to personnel and start fires. Observe all safety precautions when using soldering gun. If injury occurs, seek medical aid.
- Do not place heater near flammable material or allow heater to contact skin: severe burns can result. Wear protective equipment. If injury occurs, seek medical aid.

c. Solder two wires (1) to switch (2).

- (1) Install sleeving (3) on wires (1). Use insulation sleeving (item 105, App F).
- (2) Solder identified wires (1) to terminals (4). Use soldering gun and solder (item 189, App F) (TM 55-1500-323-24).
- (3) Position sleeving (3) on terminals (4) and shrink. Use heater.

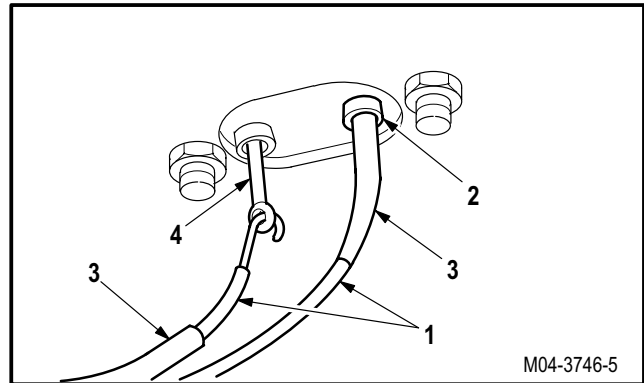

d. Inspect (QA).

e. Perform ECS maintenance operational check (TM 1-1520-238-T).

f. Install access panel L60 or R60 (para 2.2).

END OF TASK

**13.42. ECS AFT AVIONICS BAY THERMOSTATIC SWITCH REPLACEMENT**

13.42.1. Description

This task covers: Removal. Cleaning. Inspection. Installation.

13.42.2. Initial Setup

**Tools:**

- Electrical tool kit (item 378, App H)
- Light duty laboratory apron (item 27, App H)
- Chemical protective gloves (item 154, App H)
- Electric gun type heater (item 163, App H)
- Adjustable air filtering respirator (item 262, App H)
- Soldering gun (item 334, App H)

**References:**

- TM 1-1520-238-T
- TM 55-1500-323-24

**Materials/Parts:**

- Insulation sleeving (item 105, App F)
- Solder (item 189, App F)

**Personnel Required:**

- 68X Armament/Electrical System Repairer
- 68X3F Armament/Electrical System Repairer/  
Technical Inspector

**Equipment Conditions:**

<u>Ref</u>	<u>Condition</u>
1.57	Helicopter safed
2.2	Access door R295 opened

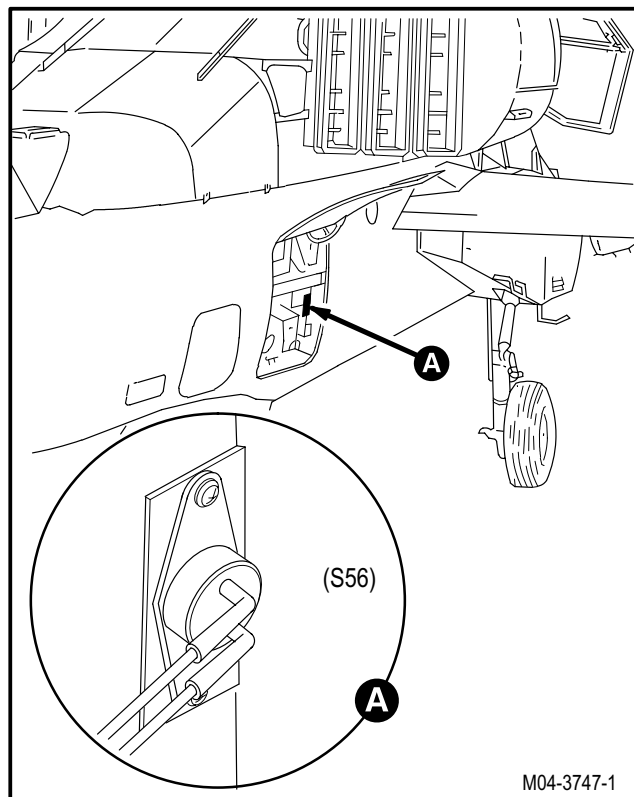

GO TO NEXT PAGE

13.42. ECS AFT AVIONICS BAY THERMOSTATIC SWITCH REPLACEMENT - continued

13.42.3. Removal



**WARNING**

**Soldering gun can cause severe burns to personnel and start fires. Observe all safety precautions when using soldering gun. If injury occurs, seek medical aid.**

a. **Desolder two wires (1) from thermostatic switch (2).**

- (1) Identify two wires (1).
- (2) Remove sleeving (3) from terminals (4).
- (3) Desolder two wires (1) from terminals (4). Use soldering gun (TM 55-1500-323-24).

b. **Remove switch (2) from bracket (5).**

- (1) Remove two screws (6) and washers (7).
- (2) Remove and discard switch (2).

13.42.4. Cleaning

a. **Clean removed and attaching parts** (para 1.47).

13.42.5. Inspection

- a. **Check wires for cuts, nicks, fraying, or chafing** (para 13.1).
- b. **Check screws for stripped or damaged threads** (para 13.1).
- c. **Check removed and attaching parts for corrosion** (para 1.49).

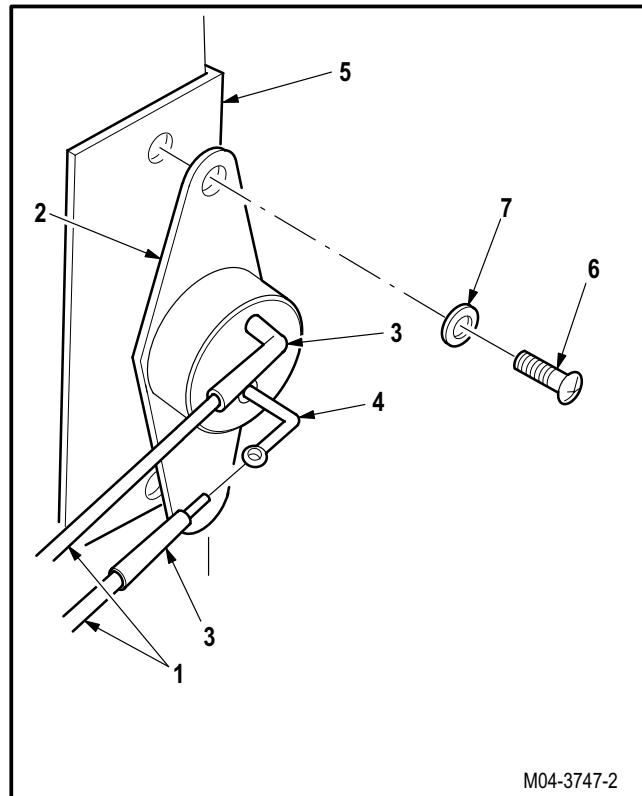

M04-3747-2

GO TO NEXT PAGE

## 13.42. ECS AFT AVIONICS BAY THERMOSTATIC SWITCH REPLACEMENT - continued

### 13.42.6. Installation

#### a. Install new switch (2) on bracket (5).

- (1) Position switch (2) on bracket (5).
- (2) Install two screws (6) and washers (7).



- Soldering gun can cause severe burns to personnel and start fires. Observe all safety precautions when using soldering gun. If injury occurs, seek medical aid.
- Do not place heater near flammable material or allow heater to contact skin: severe burns can result. Wear protective equipment. If injury occurs, seek medical aid.

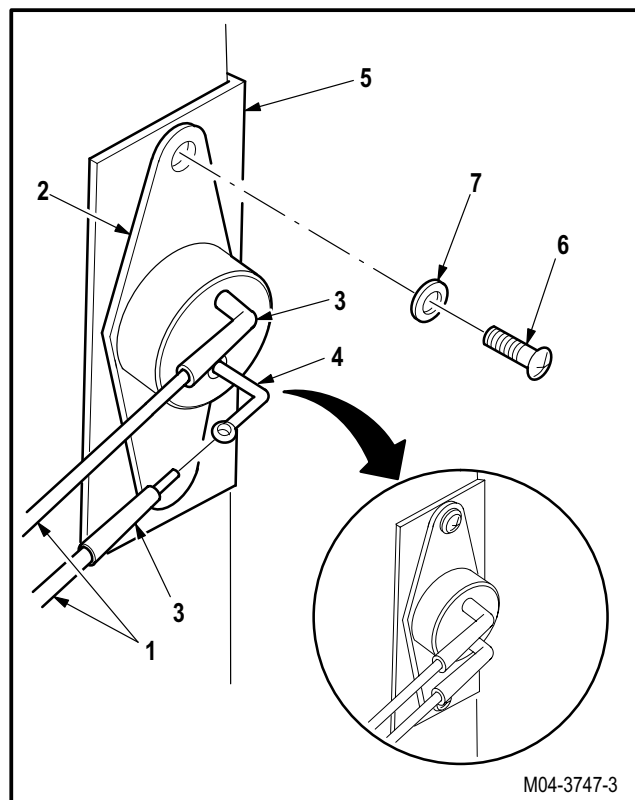

#### b. Solder two wires (1) to switch (2).

- (1) Install sleeving (3) on wires (1). Use insulation sleeving (item 105, App F).
- (2) Solder identified wires (1) to terminals (4). Use soldering gun and solder (item 189, App F) (TM 55-1500-323-24).
- (3) Position sleeving (3) on terminals (4) and shrink. Use heater.

#### c. Inspect (QA).

#### d. Perform ECS maintenance operational check (TM 1-1520-238-T).

#### e. Secure access door R295 (para 2.2).

END OF TASK

## SECTION II. DEFOG SYSTEM MAINTENANCE

### 13.43. DEFOG SYSTEM INSPECTION

#### 13.43.1. Description

This task covers: Inspection.

#### 13.43.2. Initial Setup

**Tools:**

Aircraft mechanic's tool kit (item 376, App H)

**References:**

TM 1-1500-204-23  
 TM 55-1500-323-24

**Personnel Required:**

67R      Attack Helicopter Repairer  
 67R3F   Attack Helicopter Repairer/Technical  
           Inspector

**Equipment Conditions:**

<u>Ref</u>	<u>Condition</u>
1.57	Helicopter safed

#### 13.43.3. Inspection

- a. **Check for wear and damage limits on tubes, hoses, and fittings** (TM 1-1500-204-23).
- b. **Check for chafed, cracked, dented, nicked, and scored tubes.** Replace damaged or worn tubing.
- c. **Check for chafed, deteriorated, cut, frayed, and cracked hoses.** Replace damaged or worn hoses.
- d. **Check for loose, broken, or cracked clamps.** Replace damaged clamps.
- e. **Check general mounting hardware for cracks, gouges, nicks, scratches, chafing, damage, rounded flats, and stripped or damaged threads.** Replace damaged hardware.
- f. **Check defog shut off valve for loose or missing hardware and evidence of leakage.**
- g. **Check defog shut off valve connector for loose or bent pins, thread damage, and for frayed, cut, or loose wires** (TM 55-1500-323-24).
- h. **Check defog air mixers for security of attachment and air flow during operation.**

END OF TASK

**13.44. DEFOG SHUTOFF VALVE REMOVAL/INSTALLATION**

13.44.1. Description

This task covers: Removal. Cleaning. Inspection. Installation.

13.44.2. Initial Setup

**Tools:**

- Aircraft mechanic's tool kit (item 376, App H)
- Light duty laboratory apron (item 27, App H)
- Industrial faceshield (item 129, App H)
- Chemical protective gloves (item 154, App H)
- 1 1/16 & 1 1/4-inch open end wrench (item 416, App H)
- 1 & 1 1/8-inch open end wrench (item 417, App H) (2)
- 1 3/8 & 1 7/16-inch open end wrench (item 421, App H)

**Materials/Parts:**

- Packing
- Petrolatum (item 138, App F)

**Personnel Required:**

- 67R Attack Helicopter Repairer
- 67R3F Attack Helicopter Repairer/Technical Inspector

**References:**

- TM 1-1520-238-T
- TM 55-1500-323-24

**Equipment Conditions:**

<u>Ref</u>	<u>Condition</u>
1.57	Helicopter safed
4.57	No. 1 engine louver actuator removed

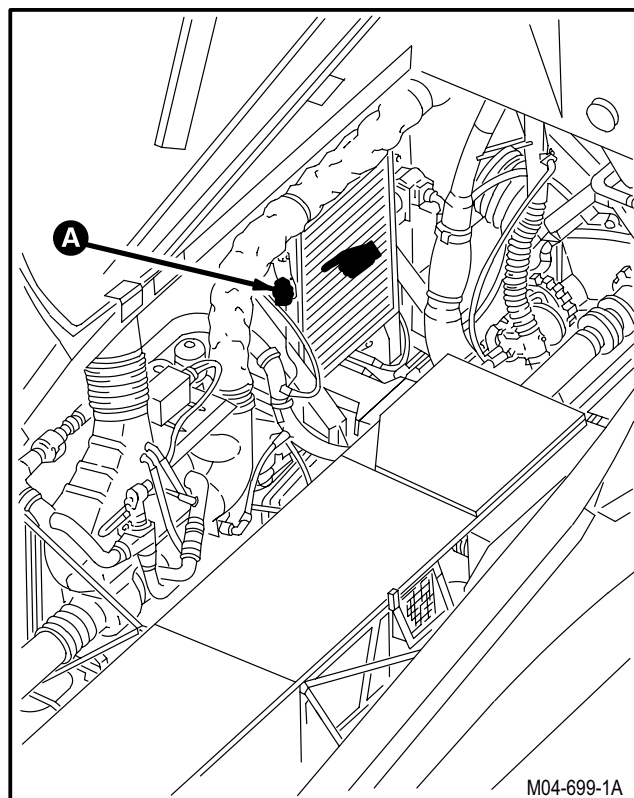

M04-699-1A

GO TO NEXT PAGE

**13.44. DEFOG SHUTOFF VALVE REMOVAL/INSTALLATION - continued**

13.44.3. Removal

a. **Detach connector P956 (1) from receptacle (L45)J1 (2).**

b. **Remove pressure outlet tube (3) from reducer (4).**

(1) Hold reducer (4). Use open end wrench.

(2) Remove nut (5). Use open end wrench.

(3) Remove tube (3).

c. **Remove pressure inlet tube (6) from defog shutoff valve (7).**

(1) Hold valve (7). Use open end wrench.

(2) Remove nut (8). Use open end wrench.

(3) Remove tube (6).

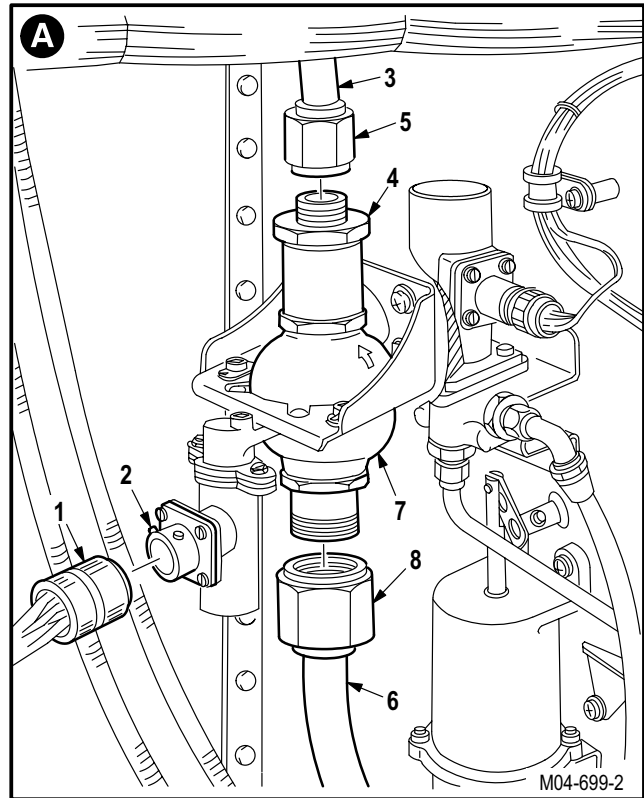

d. **Remove bracket (9) from louver enclosure assembly (10).**

(1) Remove four screws (11) and washers (12).

(2) Remove bracket (9).

e. **Remove valve (7) from bracket (9).**

(1) Remove four screws (13) and washers (14).

(2) Remove valve (7).

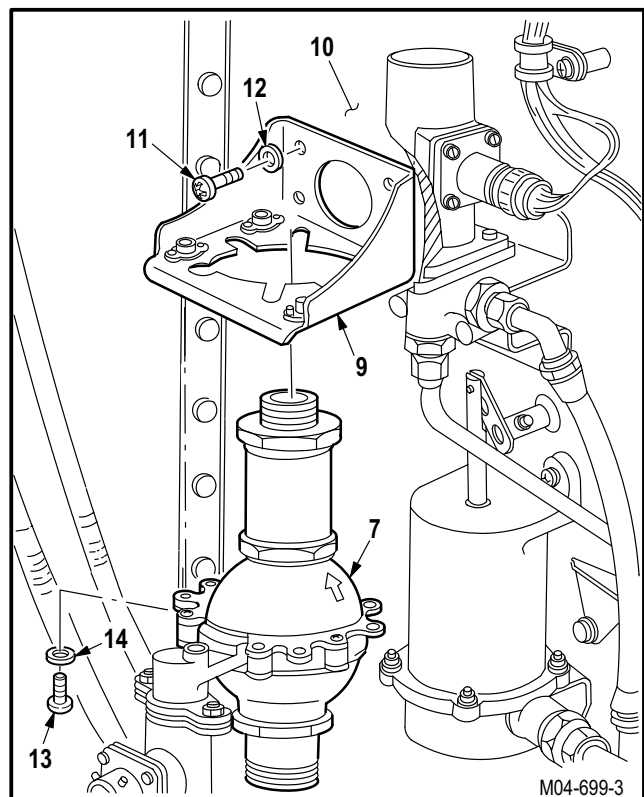

GO TO NEXT PAGE



**13.44. DEFOG SHUTOFF VALVE REMOVAL/INSTALLATION - continued****f. Remove reducer (4) from valve (7).**

- (1) Hold valve (7). Use open end wrench.
- (2) Remove reducer (4). Use open end wrench.
- (3) Remove and discard packing (15).

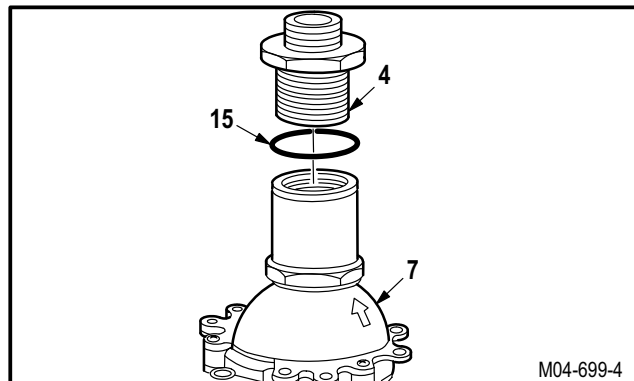
**13.44.4. Cleaning**

- a. **Clean removed parts and attaching parts** (para 1.47).

**13.44.5. Inspection**

- a. **Check valve for cracks and hoses for deterioration** (para 13.43).
- b. **Check removed and attaching parts for corrosion** (para 1.49).
- c. **Check valve for loose or missing screws.** None allowed.
- d. **Check valve for cracked or dented housing.** None allowed.
- e. **Check connector and receptacle for cracks, corrosion, and broken, bent, or damaged pins** (TM 55-1500-323-24).
- f. **Check valve for stripped or broken threads.** None allowed.
- g. **Check condition of identification plate.** No damage allowed.
- h. **Check solenoid case for damage.** None allowed.
- i. **Check valve for worn, missing or damaged coating to bare metal.** Touch up as required.

GO TO NEXT PAGE

**13.44. DEFOG SHUTOFF VALVE REMOVAL/INSTALLATION - continued**

13.44.6. Installation



**a. Install reducer (4) on valve (7).**

- (1) Lubricate new packing (15). Use petrolatum (item 138, App F).
- (2) Install packing (15) on reducer (4).
- (3) Lubricate threads of reducer (4). Use petrolatum (item 138, App F).
- (4) Hold valve (7). Use open end wrench.
- (5) Install reducer (4). Use open end wrench.

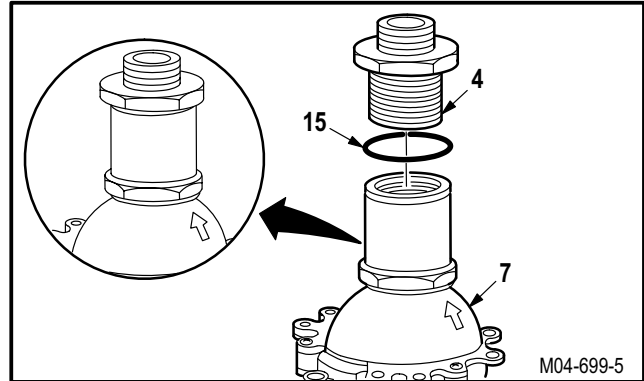

**b. Install valve (7) on bracket (9).**

- (1) Position valve (7) on bracket (9).
- (2) Install four screws (13) and washers (14).

**c. Install bracket (9) and valve (7) on louver enclosure assembly (10).**

- (1) Position bracket (9) on louver enclosure assembly (10).
- (2) Install four screws (11) and washers (12).

**d. Install tube (6) on valve (7).**

- (1) Lubricate threads of valve (7). Use petrolatum (item 138, App F).
- (2) Hold valve (7). Use open end wrench.
- (3) Install nut (8). Use open end wrench.

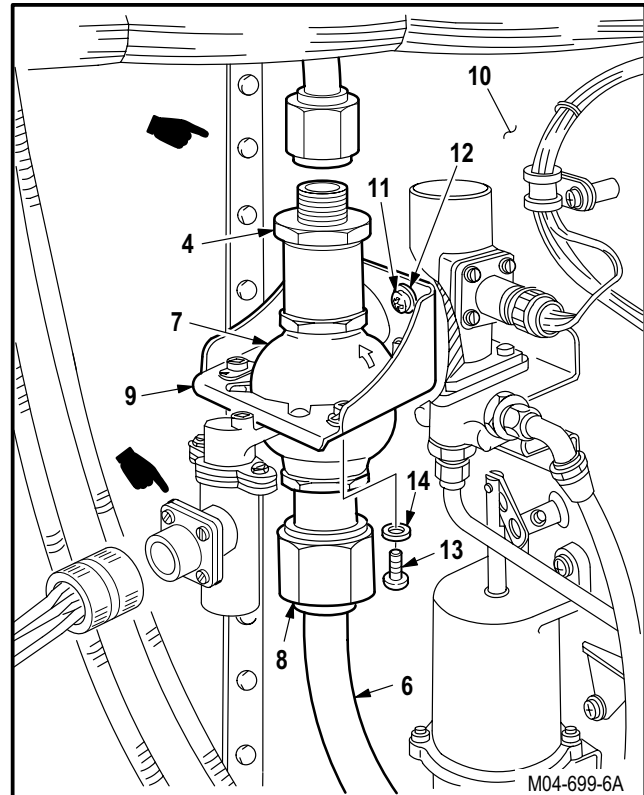

GO TO NEXT PAGE

**13.44. DEFOG SHUTOFF VALVE REMOVAL/INSTALLATION - continued****e. Install tube (3) on reducer (4).**

- (1) Lubricate threads of reducer (4). Use petrolatum (item 138, App F).
- (2) Hold reducer (4). Use open end wrench.
- (3) Install nut (5). Use open end wrench.

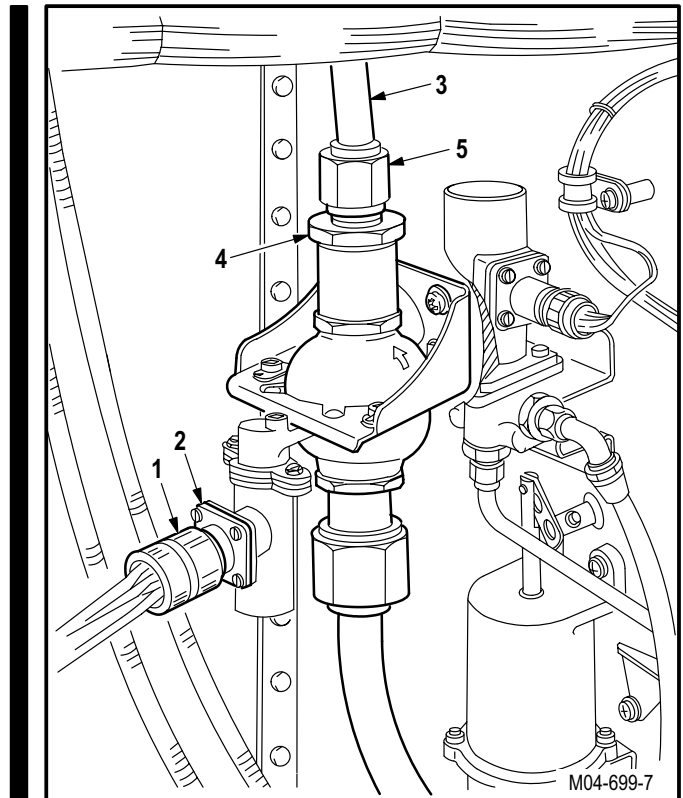
**f. Attach connector P956 (1) to receptacle (L45)J1 (2).****g. Inspect (QA).****h. Install engine No. 1 louver actuator (para 4.57).****i. Perform ECS maintenance operational check (TM 1-1520-238-T).**

END OF TASK



**13.45. DEFOG SYSTEM AIR MIXER AND HOSE REMOVAL/INSTALLATION**

13.45.1. Description

This task covers: Removal. Cleaning. Inspection. Installation.

13.45.2. Initial Setup

**Tools:**

Aircraft mechanic's tool kit (item 376, App H)

**References:**

TM 1-1520-238-T

**Equipment Conditions:**

**Personnel Required:**

67R	Attack Helicopter Repairer
67R3F	Attack Helicopter Repairer/Technical Inspector

<u>Ref</u>	<u>Condition</u>
1.57	Helicopter safed
2.2	Appropriate fairings and doors removed and opened

**NOTE**

- This task is typical for pilot and CPG air mixers, hose, and other defog system components.
- Hose must not be twisted, stretched, kinked, or flattened during removal or installation.

GO TO NEXT PAGE

13.45. DEFOG SYSTEM AIR MIXER AND HOSE REMOVAL/INSTALLATION - continued

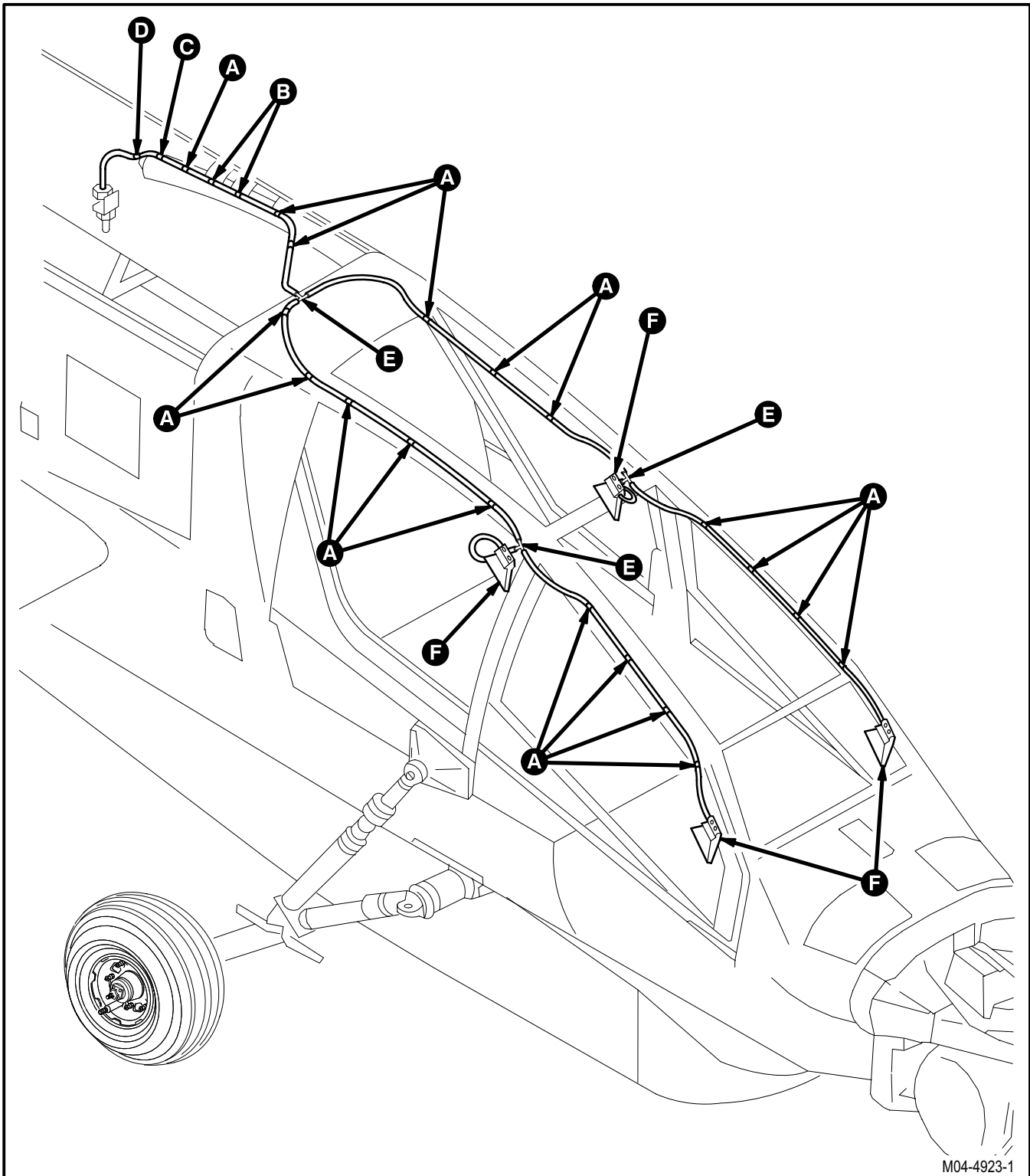

M04-4923-1

GO TO NEXT PAGE

---

**13.45. DEFOG SYSTEM AIR MIXER AND HOSE REMOVAL/INSTALLATION - continued**



---

13.45.3. Removal**NOTE**

Some clamp stack-ups will not have washers.

**a. Remove hose (1) from airframe (2).**

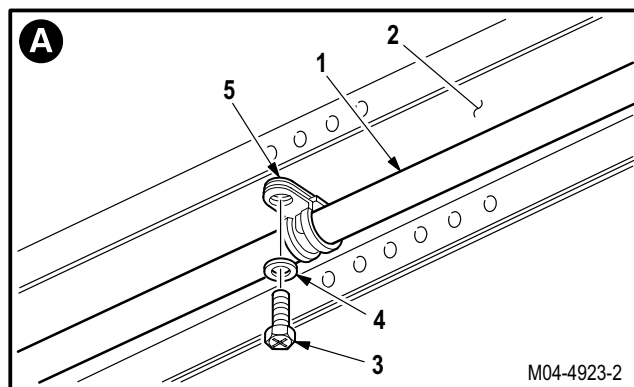
- (1) Remove screw (3) and washer (4) from clamp (5).
- (2) Remove clamp (5) from hose (1).

**b. Remove hose (6) from bracket (7).**

- (1) Hold nut (8). Remove screw (9) and washer (10) from clamps (11) and (12).
- (2) Remove clamp (11) from hose (6).

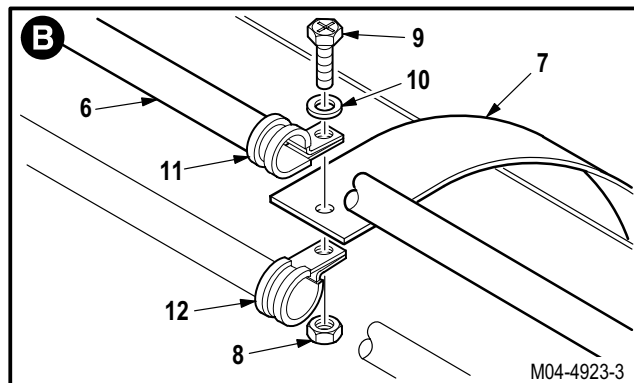
**c. Remove hose (13) from bracket (14).**

- (1) Hold nut (15). Remove screw (16) and washer (17) from clamp (18).
- (2) Remove clamp (18) from hose (13).

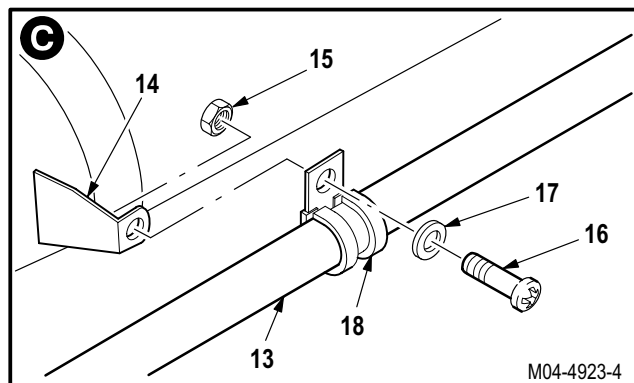

GO TO NEXT PAGE

**13.45. DEFOG SYSTEM AIR MIXER AND HOSE REMOVAL/INSTALLATION - continued**

**d. Remove hose (19) from tube (20).**

- (1) Loosen clamp (21).
- (2) Remove hose (19) and clamp (21).

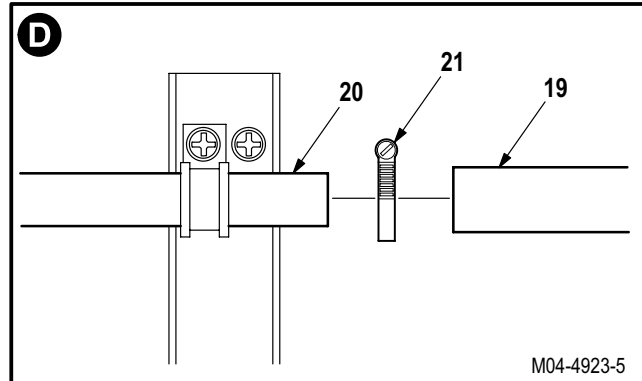

**e. Remove hose (22) from tee fitting (23).**

- (1) Loosen clamp (24).
- (2) Remove hose (22) and clamp (24).

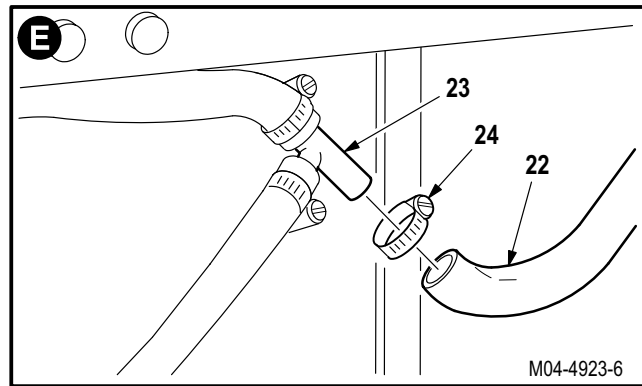

**f. Enter pilot or CPG station (para 1.56). Observe all safety precautions.**

**g. Remove hose (25) from air mixer (26).**

- (1) Loosen clamp (27).
- (2) Remove hose (25) from nipple (28).

**h. Remove mixer (26) from bracket (29).**

- (1) Remove two screws (30) and washers (31).
- (2) Remove mixer (26).

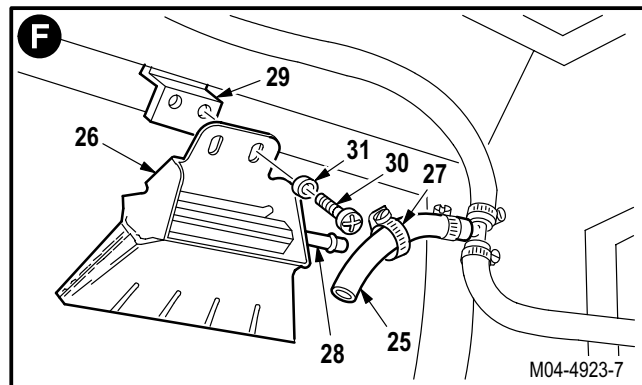

**13.45.4. Cleaning**

- a. **Clean removed and attaching parts with a clean rag.**

**13.45.5. Inspection**

- a. **Check air mixers and tees for cracks** (para 13.43).
- b. **Check hoses for cracks, cuts, chafing, and deterioration** (para 13.43).
- c. **Check removed and attaching parts for corrosion** (para 1.49).

GO TO NEXT PAGE



---

**13.45. DEFOG SYSTEM AIR MIXER AND HOSE REMOVAL/INSTALLATION - continued**

---

13.45.6. Installation

a. **Enter pilot or CPG station (para 1.56). Observe all safety precautions.**

b. **Install mixer (26) on bracket (29).**

- (1) Position mixer (26) on bracket (29).
- (2) Install two screws (30) and washers (31).

c. **Install hose (25) on mixer (26).**

- (1) Install clamp (27) on hose (25).
- (2) Install hose (25) on nipple (28).
- (3) Tighten clamp (27).

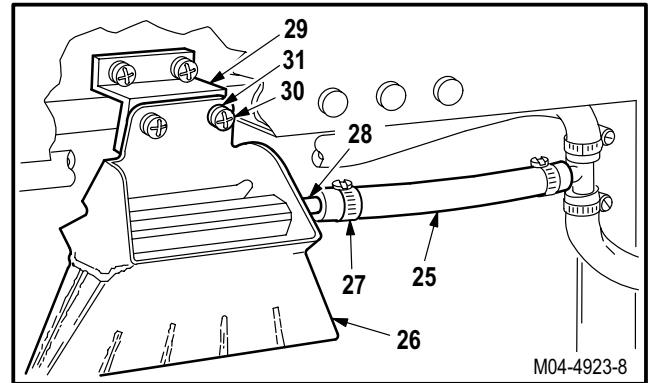

d. **Install hose (22) on tee (23).**

- (1) Install clamp (24) on hose (22).
- (2) Install hose (22) on tee (23).
- (3) Tighten clamp (24).

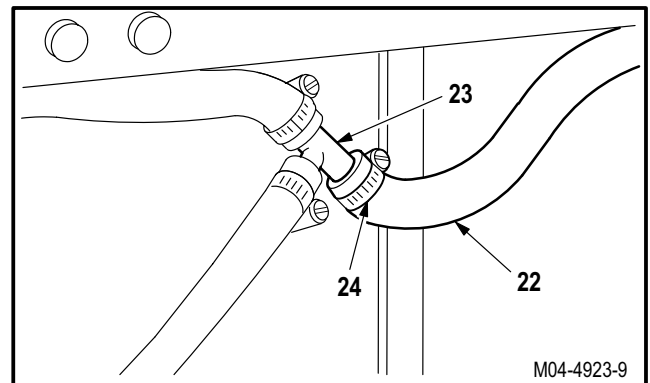

e. **Install hose (19) on tube (20).**

- (1) Install clamp (21) on hose (19).
- (2) Install hose (19) on tube (20).
- (3) Tighten clamp (21).

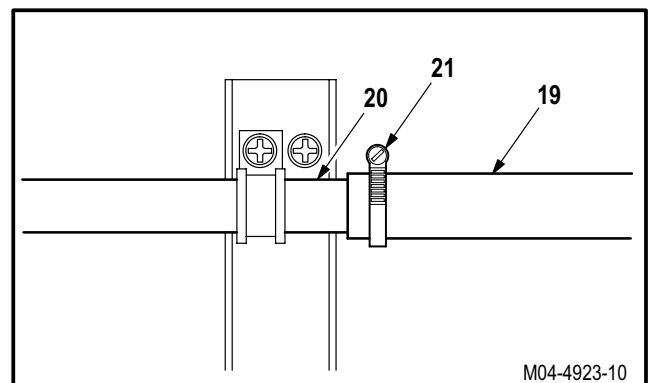

GO TO NEXT PAGE

**13.45. DEFOG SYSTEM AIR MIXER AND HOSE REMOVAL/INSTALLATION - continued**

**f. Install hose (13) on bracket (14).**

- (1) Install clamp (18) on hose (13).
- (2) Position clamp (18) on bracket (14).
- (3) Install screw (16) through washer (17), clamp (18), bracket (14), and nut (15).

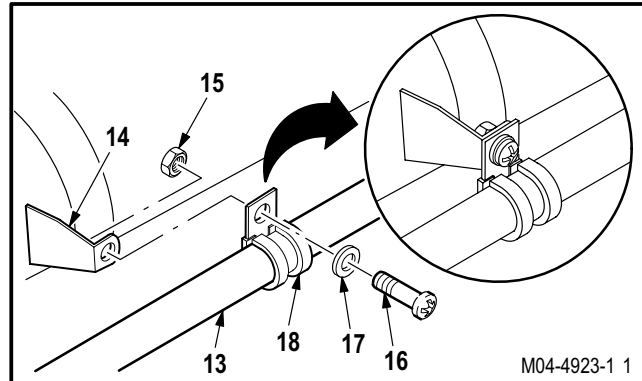

**g. Install hose (6) on bracket (7).**

- (1) Install clamp (11) on hose (6).
- (2) Position clamp (11) on bracket (7).
- (3) Install screw (9) through washer (10), clamp (11), bracket (7), clamp (12), and nut (8).

**NOTE**

Some clamp stack-ups will not have washers.

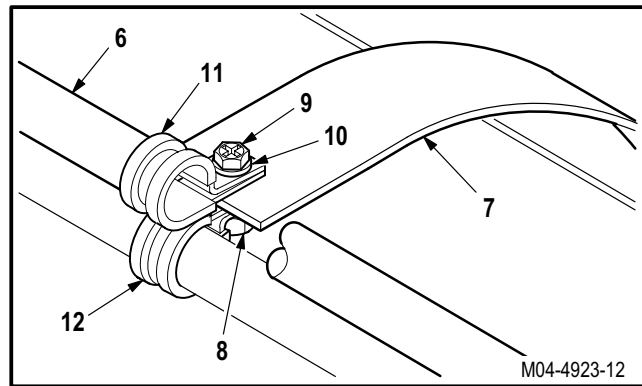

**h. Install hose (1) on airframe (2).**

- (1) Install clamp (5) on hose (1).
- (2) Position clamp (5) on airframe (2).
- (3) Install screw (3) and washer (4) on clamp (5).

**i. Inspect (QA).**

**j. Perform ECS maintenance operational check (TM 1-1520-238-T).**

**k. Install and secure appropriate fairings and doors (para 2.2).**

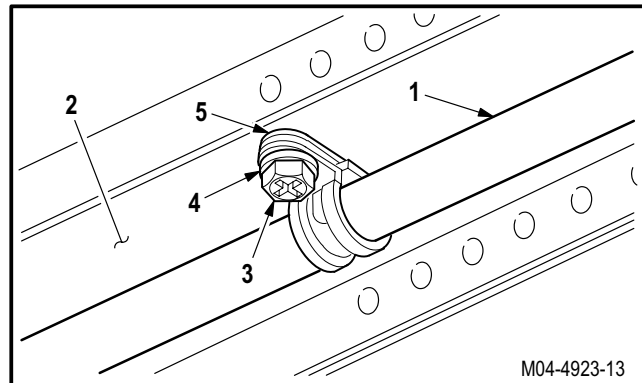

END OF TASK

CHAPTER 14  
HOISTS AND WINCHES

(NOT APPLICABLE)



## CHAPTER 15 AUXILIARY POWER SYSTEM

### CHAPTER OVERVIEW

Chapter 15 contains the maintenance instructions for the auxiliary power system. Auxiliary power system description, operation, and troubleshooting information is contained in TM 1-1520-238-T.

#### NOTE

All deleted tasks can be found in TM 1-2835-213-23.

### CHAPTER INDEX

<u>Para Title</u>	<u>Para No.</u>
<b>SECTION I. AUXILIARY POWER SYSTEM MAINTENANCE</b>	
Auxiliary Power System Components Inspection .....	15.1
APU Removal .....	15.2
APU Installation .....	15.3
APU Motional Transducer Removal/Installation .....	Deleted
APU Gearbox Oil Filler Cap Removal/Installation .....	Deleted
APU Oil Filter Replacement .....	Deleted
APU Oil Level Sight Gage Indicator Replacement .....	Deleted
APU Low Oil Pressure (LOP) Switch Removal/Installation .....	Deleted
APU Chip Collector and Magnetic Drain Plug Replacement .....	Deleted
APU Wiring Harness Removal .....	Deleted
APU Wiring Harness Installation .....	Deleted
APU Wiring Harness Angle Bracket Replacement .....	Deleted
APU START/RUN/OFF Switch Replacement .....	15.13
APU Power Take-Off (PTO) Clutch Removal/Installation .....	Deleted

CHAPTER INDEX - continued

<u>Para Title</u>	<u>Para No.</u>
APU Power Take-Off (PTO) Clutch Solenoid Valve Removal/Installation .....	Deleted
APU Power Take-Off (PTO) Clutch Solenoid Valve Disassembly/Assembly .....	Deleted
APU Fuel Control Removal/Installation .....	Deleted
APU Fuel Filter Replacement .....	Deleted
APU Fuel Solenoid Valve Removal/Installation .....	Deleted
APU Fuel Supply Hose Replacement .....	15.20
APU Fuel Solenoid Support Bracket Removal/Installation .....	Deleted
APU Fuel Drain Check Valve Removal/Installation .....	Deleted
APU Controller Removal/Installation .....	15.23
APU Time Totalizing Meter Removal/Installation .....	15.24
APU Ignition Exciter Unit Removal/Installation .....	Deleted
APU Ignition Exciter Unit Bracket Removal/Installation .....	Deleted
APU Combustor Liner, Cap, Fuel Nozzle, and Igniter Plug Removal/Installation .....	Deleted
APU Exhaust Gas Temperature (EGT) Thermocouple Removal/Installation .....	Deleted
APU Identification Plate Replacement .....	Deleted
APU Hydraulic Starter Removal/Installation .....	Deleted

**SECTION II. AUXILIARY POWER UNIT MOUNTING AND DRAIN SYSTEM**

APU Aft Support Strut and Rod End Removal/Installation .....	15.31
Right Truss Removal/Installation .....	15.32
Left Truss Assembly Removal/Installation .....	15.33
APU Support Deck Fitting Removal/Installation .....	15.34
APU Aft Fitting Removal/Installation .....	15.35
APU Forward Left or Right Mount Fitting Replacement .....	15.36
APU Plenum Drain Hose Replacement .....	15.37

CHAPTER INDEX - continued

<u>Para Title</u>	<u>Para No.</u>
APU Hydraulic Drain Hose Removal/Installation .....	15.38
APU Drain Tube Removal/Installation .....	15.39
 <b>SECTION III. AUXILIARY POWER UNIT EXHAUST SYSTEM AND ENCLOSURE</b>	
APU Exhaust Nozzle and Duct Removal/Installation .....	15.40
APU Enclosure Removal .....	15.41
APU Enclosure Installation .....	15.42
APU Enclosure Support Brackets Removal/Installation .....	15.43

## SECTION I. AUXILIARY POWER SYSTEM MAINTENANCE

### 15.1. AUXILIARY POWER SYSTEM COMPONENTS INSPECTION

#### 15.1.1. Description

This task covers: Inspection.

#### 15.1.2. Initial Setup

**Tools:**

Aircraft mechanic's tool kit (item 376, App H)  
 9/64-inch L-handle socket head screw key (item 188, App H)

**References:**

TM 1-1500-204-23  
 TM 1-2835-213-23  
 TM 55-1500-323-24  
 TM 55-1500-335-23

**Personnel Required:**

67R Attack Helicopter Repairer  
 67R3F Attack Helicopter Repairer/Technical Inspector

**Equipment Conditions:**

<u>Ref</u>	<u>Condition</u>
1.57	Helicopter safed
2.2	Access panels removed as necessary

#### 15.1.3. Inspection

**NOTE**

For APU limits or allowable repairs not listed in this chapter refer to TM 1-2835-213-23.

- a. **Check APU enclosure for delaminated or cracked panels, covers, and bulkhead** (para 2.12).
- b. **Check APU enclosure for loose, missing, or damaged hook-and-pile fasteners, stud fasteners, turn-lock receptacles, nutplates, doublers, seals, and clips** (TM 1-1500-204-23).
- c. **Check all APU components for dents, cracks, damaged connectors, loose or missing hardware, and leaks. Check gear case line for leakage, five drops per hour maximum allowable.**
- d. **Check all APU electrical connectors and wiring for security, damage, loose or missing hardware, fraying, and chaffed or missing insulation** (TM 55-1500-323-24).
- e. **Check all APU components for crossed, stripped, or galled threads.** None allowed.
- f. **Check APU hydraulic starter mounting areas for cracks.** None allowed.
  - (1) Fluorescent-penetrant inspect if cracks are suspected (TM 55-1500-335-23).
- g. **Check APU hydraulic starter for leaks.** Outboard seal shall not exceed one drop in **FIVE MINUTES**.

GO TO NEXT PAGE



---

**15.1. AUXILIARY POWER SYSTEM COMPONENTS INSPECTION - continued**

---

**NOTE**

Grease may vent through the vent port under certain conditions such as overfilling or operating under high ambient temperatures. Under these conditions, wipe grease away from housing and continue to use power take-off assembly. Oil stains or wetness appearing on the covered port at the bottom of the PTO clutch housing is acceptable. If oil is leaking from the covered port, the clutch shall be replaced if the leakage rate exceeds 1 drop per minute with APU running.

**h. Check APU power take-off clutch for external oil or grease leaks, heat discoloration, and cracks.**

- (1) Fluorescent-penetrant inspect if cracks are suspected (TM 55-1500-335-23).

**NOTE**

External oil leakage is most likely to be at covered port. Do not confuse grease at this location with grease coming from duplex vent. Grease from duplex vent will migrate to the covered port area. External grease leakage is most likely to be at forward lip seal and duplex vent. Heat discoloration is usually confined to duplex bearing housing area.

- (2) Grease discharge from covered port. None allowed.  
 (3) Oil discharge from covered port shall not exceed 1 drop per minute with APU running.

**i. Check APU power take-off clutch for internal oil or grease leaks, heat blackening, and friction disk wear.****NOTE**

Friction disk has four uniformly spaced radial grooves cut into its surface. Measurements must be taken in area between grooves.

- (1) **Deleted.**  
 (2) Wetness from duplex vent port and covered port is acceptable.

**j. Check APU fuel control quill shaft for cracks, damaged splines, and other damage. None allowed.****k. Check APU fuel solenoid valve for damage.**

- (1) Check for gap between the coil assembly and valve body. None allowed.  
 (2) Check for yielded or deformed cover assembly, especially near screw heads. None allowed.

**l. Check APU combustor liner for distortion.**

- (1) Distortion greater than **0.125 INCH** is not allowed.

**m. Check APU combustor liner for cracks.**

- (1) Cracks connecting any holes, separated by less than **0.250 INCH** of material, greater than **0.125 INCH**, or located to threaten material breakaway not allowed.

**n. Check APU combustor liner for thinning.**

GO TO NEXT PAGE

---

**15.1. AUXILIARY POWER SYSTEM COMPONENTS INSPECTION - continued**

---

- (1) Thinning below **0.016 INCH** is not allowed.
- o. **Check APU combustor cap flange for deformation.** Deformation greater than **0.125 INCH** not allowed.
- p. **Check fuel nozzle for cracks.** None allowed.
- q. **Check igniter plug ceramic insulation for cracks and chips.** None allowed.
- r. **Check igniter plug electrode for damage.**
  - (1) Protrusion less than **0.010 INCH** above ceramic insulation not allowed.
- s. **Check ignition lead for burned spots, cracked or chafed insulation, and any other damage.** None allowed.
- t. **Check APU exhaust nozzle and duct for leaks, cracks, dents, and distortion.** Use depth gage.
  - (1) Dents and distortion shall not exceed **0.125 INCH**.
- u. **Check APU exhaust nozzle and duct for oxidation erosion and pitting.** Use depth gage. Oxidation erosion and pitting shall not exceed **0.050 INCH**.
- v. **Inspect exhaust duct insulation for cracks, tears, holes, or punctures.** If cracks, tears, holes, or punctures are found and are less than four inches, repair (para 15.40).
- w. **Check exhaust duct for gaps in weld areas located between duct and insulation.** If gaps in weld are found, insulation may be rolled back four inches or less, repair (para 15.40).
- x. **Check exhaust duct for dents that exceed 0.500 INCH in depth.** None allowed.
- y. **Check APU support strut and truss assemblies for cracks, dents, scratches, distortion, loose bolts, and elongated holes.**
  - (1) Fluorescent-penetrant inspect if cracks are suspected (TM 55-1500-335-23). Replace if cracks are found.
  - (2) Scratches **0.010 INCH** maximum must be blended out. Replace if scratches are deeper than **0.010 INCH**.
  - (3) Dents shall not exceed **0.010 INCH** and must be blended out. Replace if dents are deeper than **0.010 INCH**.
  - (4) Check the entire length of each weld line for cracks and any other abnormalities. Use inspection mirror as required.
- z. **Check APU support strut and truss assemblies for corrosion** (para 1.49).
- aa. **Check APU support strut and truss assemblies attachment points for loose or missing hardware. All bushings must be in place and hardware must be securely torqued** (para 15.31/para 15.32/para 15.33).
- ab. **Check length of aft support strut** (para 15.31).
- ac. **Check the APU deck fittings for detectable motion, cracks, elongated holes, and missing hardware** (para 15.34/para 15.35). None allowed.
- ad. **Secure removed panels as necessary** (para 2.2).

END OF TASK

## 15.2. APU REMOVAL

### 15.2.1. Description

This task covers: Removal. Cleaning. Inspection.

### 15.2.2. Initial Setup

#### Tools:

Aircraft mechanic's tool kit (item 376, App H)  
 Maintenance platform (item 210, App H)  
 1 1/2 & 1 5/8-inch open end wrench (item 418, App H)  
 (2)  
 1 1/4 & 1 5/16-inch open end wrench (item 419, App H)  
 1 3/8 & 1 7/16-inch open end wrench (item 421, App H)

#### Materials/Parts:

Tag Line (2)

#### Personnel Required:

67R Attack Helicopter Repairer  
 Two persons to assist

#### Equipment Conditions:

Ref	Condition
1.57	Helicopter safed
1.104	Maintenance crane adjusted - APU
6.16	No. 7 drive shaft removed
7.57	Utility hydraulic system vented

### WARNING

- **APU is easy to start. Disconnect battery. Remove all other electrical power before performing any maintenance in this area. Death or serious injury could result if APU starts. If injury occurs, seek medical aid.**
- **The fuel solenoid shutoff valve should not be used as a handhold at any time. Doing so could result in fuel leakage and possible fire.**

### 15.2.3. Removal

- a. **Enter pilot station (para 1.56). Observe all safety precautions.**
- b. **On pilot center circuit breaker panel, open FUEL APU and APU HOLD circuit breakers.**

#### NOTE

Place rags under work area to catch fluid.

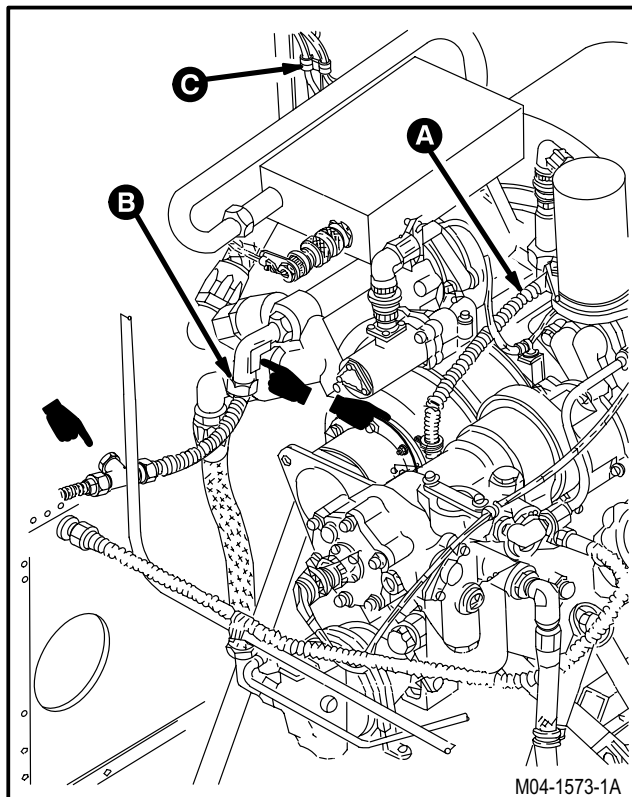

GO TO NEXT PAGE

15.2. APU REMOVAL - continued

c. Remove APU plenum fuel drain hose (1) from APU fuel drain check valve (2).

(1) Hold valve (2). Remove nut (3).

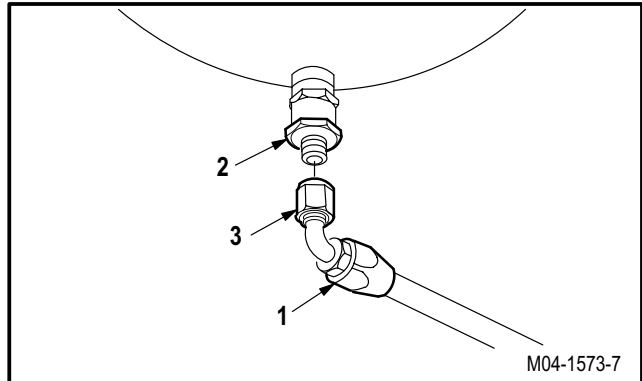

d. Remove fuel supply hose (4) from elbow (5).

(1) Hold elbow (5). Remove nut (6).

e. Remove fuel control drain hose (7) from nipple (8).

(1) Hold nipple (8). Remove nut (9).

f. Remove clamp (10) from PTO clutch (11).

(1) Remove nut (12) and washer (13) from bolt (14).

(2) Remove bolt (14).

g. Remove clamps (15) and (16).

(1) Remove nut (17) from bolt (18).

(2) Remove bolt (18) and washer (19).

(3) Remove clamps (15) and (16).

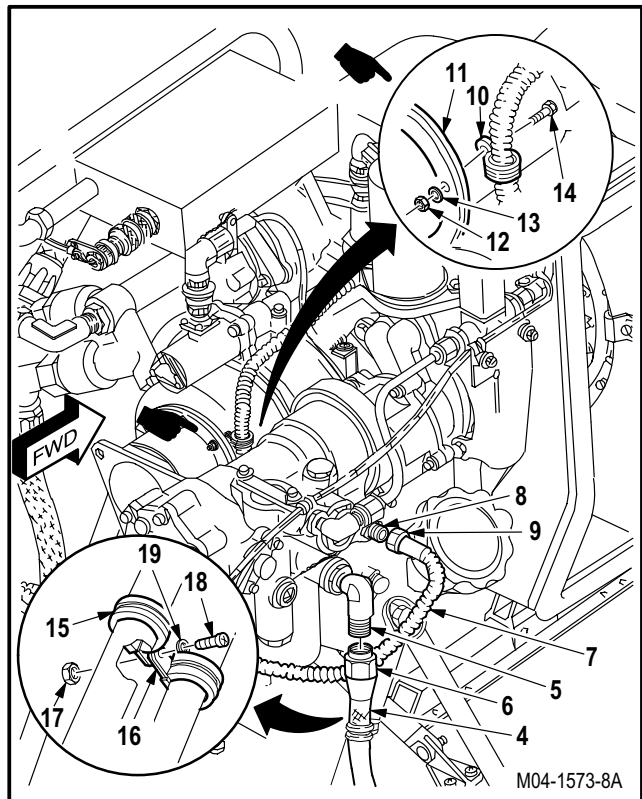

h. Remove gearbox vent hose (20) from adapter (21).

(1) Hold adapter (21). Remove nut (22).

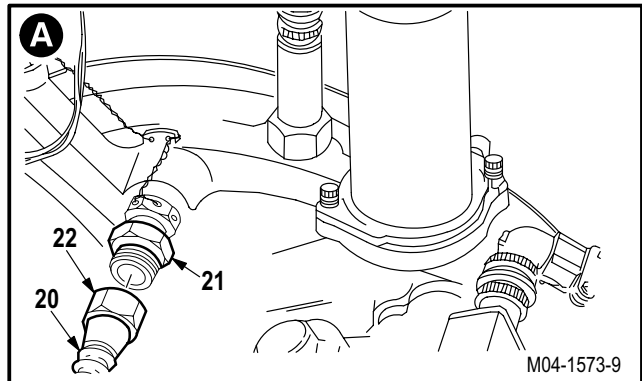

GO TO NEXT PAGE

**15.2. APU REMOVAL - continued**

**i. Remove hydraulic starter drain hose (23).**

- (1) Hold elbow (24). Remove nut (25).

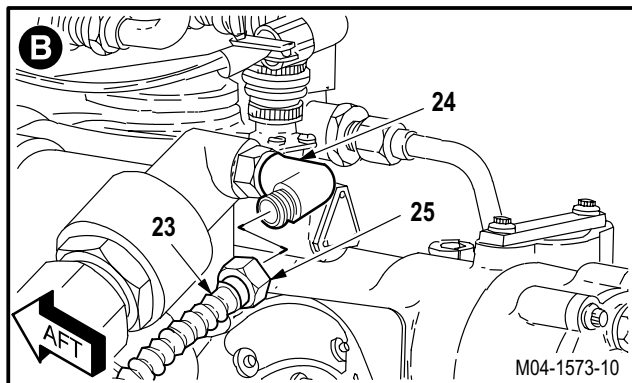

**j. Remove starter return hose (26) from nipple (27).**

- (1) Hold nipple (27). Remove nut (28). Use open end wrench.

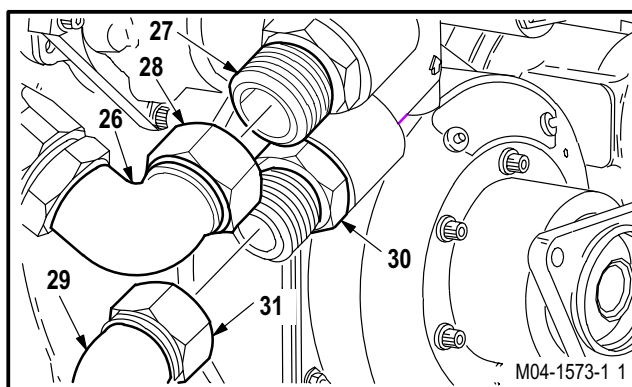

**k. Remove hydraulic starter pressure hose (29) from nipple (30).**

- (1) Hold nipple (30). Remove nut (31). Use open end wrench.

**l. Remove clamp (32) from clamp (33).**

- (1) Remove nut (34) and washer (35) from screw (36).
- (2) Remove screw (36) from clamps (32) and (33).
- (3) Remove clamp (32) from wire harness (37).

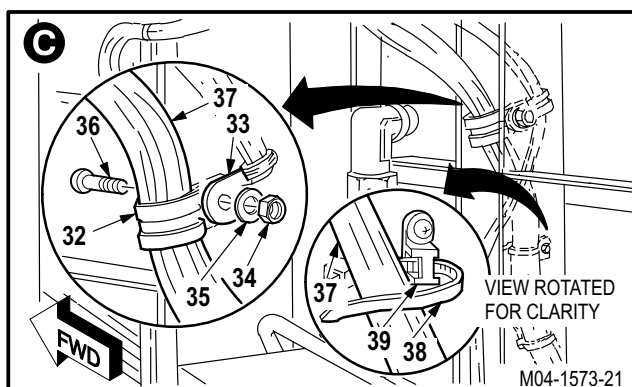

**m. Remove two tiedown straps (38) from harness (37).**

- (1) Remove two straps (38) from anchors (39) and harness (37).

GO TO NEXT PAGE

15.2. APU REMOVAL - continued

**WARNING**

Inspect APU lifting lug for damage, bends, or cracks. Failure of lifting lug can cause structural damage or injury to personnel. If an injury occurs, seek medical aid.

- n. Insert lifting hook (40) into APU lifting lug (41).
- o. Lift APU (42) with crane until weight is off APU mounts.
- p. Install tag lines (43) to APU.

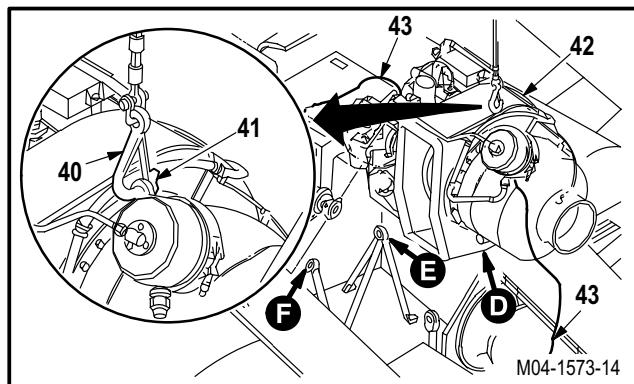

- q. Remove support strut (44) from APU aft mount bracket (45) and fitting (46).

- (1) Remove two nuts (47) and washers (48) from bolts (49).
- (2) Remove bolt (49) and bushing (50) from clevis (51) and mount (45).
- (3) Remove bolt (49) and bushing (52) from fitting (46) and rod end (53).

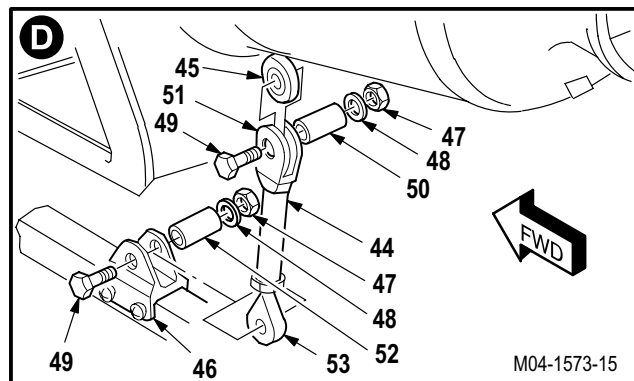

- r. Remove right APU mount bolt (54) from right truss (55).

- (1) Remove lockwire from bolt (54).
- (2) Remove bolt (54) and washer (56).

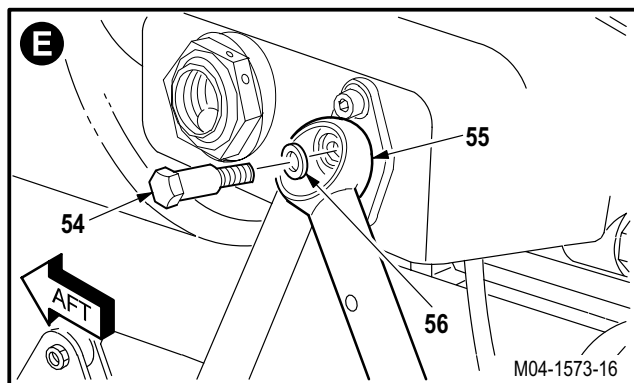

GO TO NEXT PAGE

15.2. APU REMOVAL - continued

s. Remove left APU mount bolt (57) from left truss (58).

- (1) Remove lockwire from bolt (57).
- (2) Remove bolt (57) and washer (59).
- (3) Remove two nuts (60) and washers (61) from bolts (62).
- (4) Remove two bolts (62) and bushings (63).

**NOTE**

When lifting APU from mounts, ensure that all hoses and electrical connectors are clear of APU.

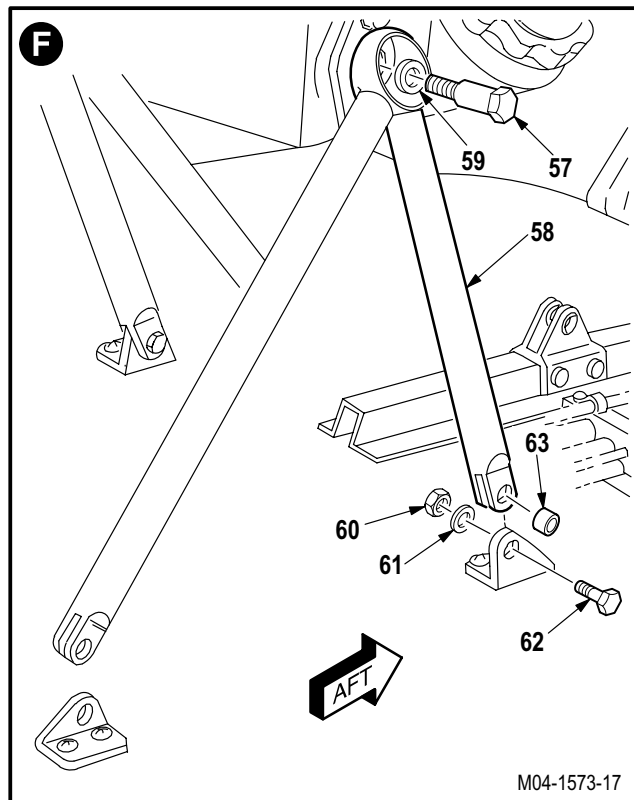

t. Lift APU (42) from helicopter.

u. Install APU (42) on APU workstand (64).

- (1) Aline mount (65) with support (66).
- (2) Aline mount (45) with support (67).

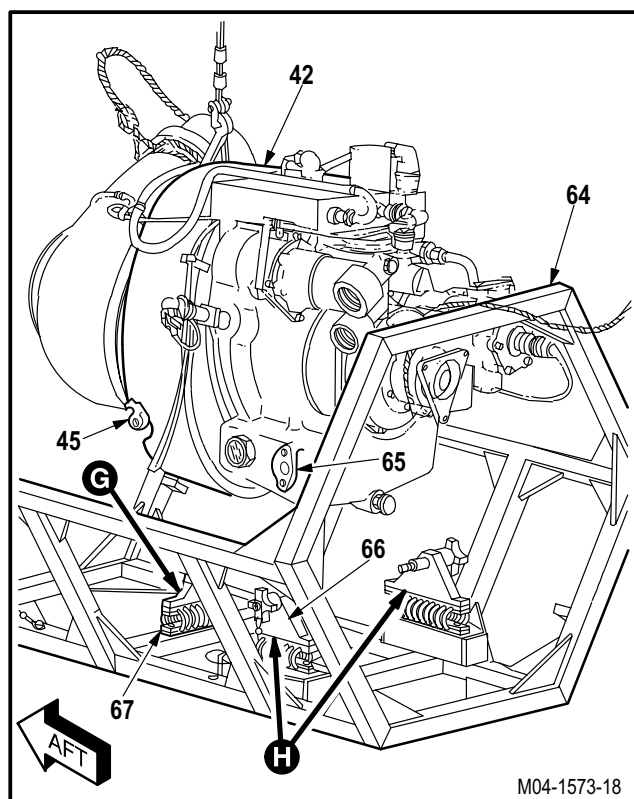

GO TO NEXT PAGE

**15.2. APU REMOVAL - continued**

(3) Install pin (68) through support (66) and mount (45).

(4) Install two knobs (69) in mounts (65).

**v. Remove lifting hook (40) from APU lifting lug (41).**

(1) Release tension on lifting cable and remove hook (40).

**w. Remove tag lines (43).**

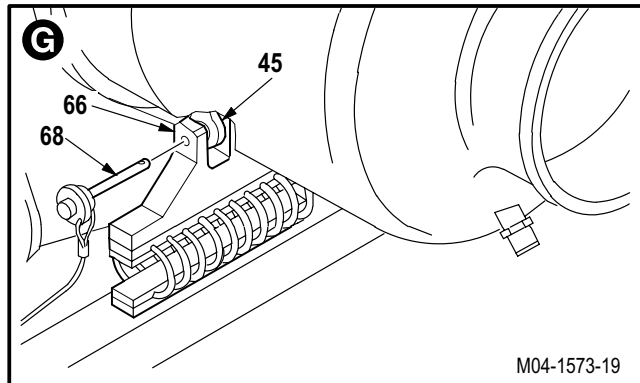

**15.2.4. Cleaning**

a. **Clean removed and attaching parts** (para 1.47).

**15.2.5. Inspection**

a. **Check trusses and supports for cracks, dents, distortion, elongated holes, and loose attachment** (para 15.1).

b. **Check trusses and supports for corrosion** (para 1.49).

c. **Check length of aft support strut** (para 15.31).

d. **Check support strut for cracks and bends** (para 15.1).

e. **Check the APU deck fittings for detectable motion, cracks, elongated holes, and missing hardware** (para 15.34/para 15.35). None allowed.

f. **Check exhaust nozzle for cracks, dents, and distortion** (para 15.1).

g. **Check hoses and coupling nuts for cracks, bends, or stripped threads** (para 15.1).

h. **Check removed and attaching parts for corrosion** (para 1.49).

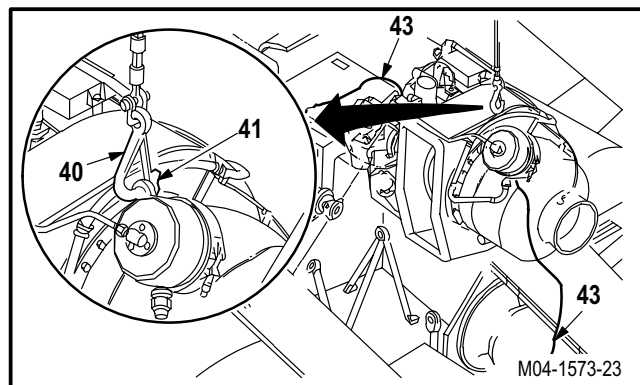
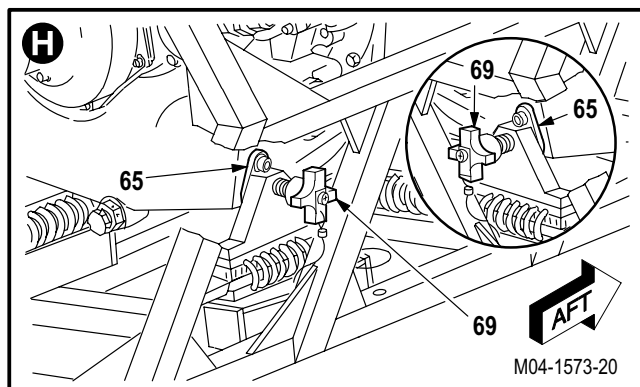

END OF TASK



### 15.3. APU INSTALLATION

#### 15.3.1. Description

This task covers: Installation.

#### 15.3.2. Initial Setup

##### **Tools:**

- Aircraft maintenance tool kit (item 371, App H)
- Light duty laboratory apron (item 27, App H)
- Chemical protective gloves (item 154, App H)
- Maintenance platform (item 210, App H)
- Adjustable air filtering respirator (item 262, App H)
- 1 1/2 & 1 5/8-inch open end wrench (item 418, App H)  
(2)
- 1 1/4 & 1 5/16-inch open end wrench (item 419, App H)
- 1 3/8 & 1 7/16-inch open end wrench (item 421, App H)
- 30 - 150 inch-pound 1/4-inch drive click type torque wrench (item 435, App H)

##### **Materials/Parts:**

- Tag line (2)
- Brush (item 34, App F)
- Hydraulic fluid (item 92, App F)
- Petrolatum (item 138, App F)
- Sealing compound (item 177, App F)
- Strap (item 192, App F)
- Wire (item 226, App F)
- Metal conditioning compound (item 123B, App F)
- Disposable applicator (item 29B, App F)
- Primer (item 142A, App F)
- Polyurethane coating (item 141, App F)
- Sealing compound (item 176, App F)

##### **Personnel Required:**

- 67R Attack Helicopter Repairer  
Two persons to assist
- 67R3F Attack Helicopter Repairer/Technical Inspector

##### **References:**

TM 1-1520-238-T

##### **Equipment Conditions:**

<u>Ref</u>	<u>Condition</u>
1.57	Helicopter safed

**WARNING**

**The fuel solenoid shutoff valve should not be used as a handhold at any time. Doing so could cause looseness of the valve and result in fuel leakage and possible fire.**

GO TO NEXT PAGE

15.3. APU INSTALLATION - continued

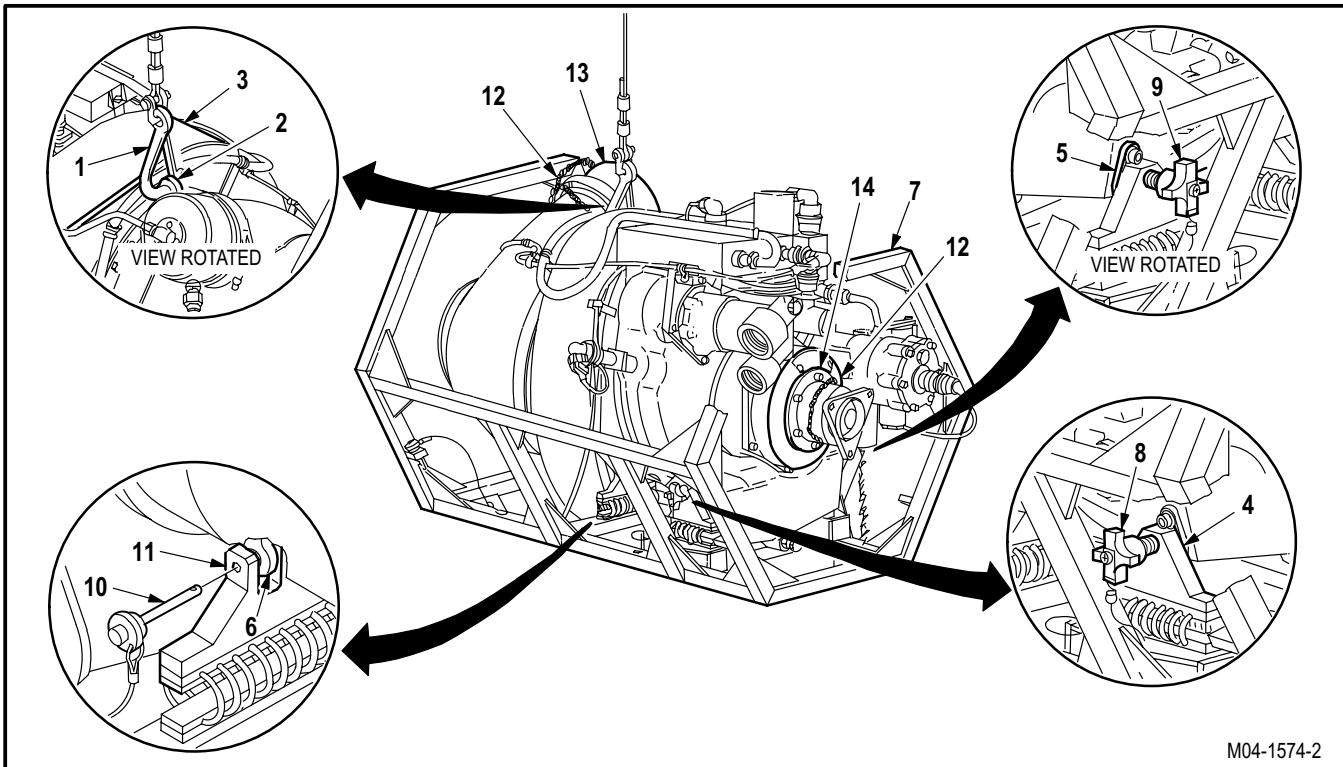

**WARNING**

Inspect lifting lug for damage, bends, or cracks. Insure lifting hook or clevis is of proper size to prevent side loads from being imposed on lifting lug. Failure of lifting lug can cause structural damage or injury personnel. If injury occurs, seek medical aid.

- a. Insert lifting hook (1) into APU lifting lug (2).
- b. Lift APU (3) with crane until weight is off mounts (4), (5), and (6).
- c. Remove APU (3) from APU workstand (7).
  - (1) Remove workstand knobs (8) and (9) from mounts (4) and (5).
  - (2) Remove pin (10) from support (11) and mount (6).
  - (3) Attach tag lines (12) to combustor cap (13) and PTO clutch (14).

GO TO NEXT PAGE

15.3. APU INSTALLATION - continued

d. Lift APU (3) and position over mounting area.

**CAUTION**

When lowering APU onto mounts, ensure all hoses and electrical connections are free and clear of APU.

e. Lower APU (3) into mounting area.

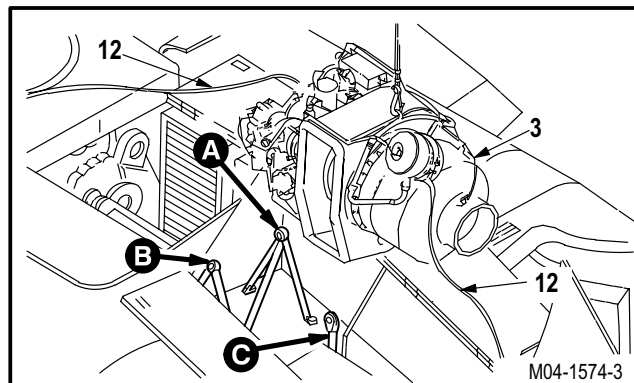

f. Install APU mount bolt (15) through right truss (16) and mount (4).

- (1) Aline mount (4) with truss (16).
- (2) Install bolt (15) through washer (17) and truss (16) into mount (4).

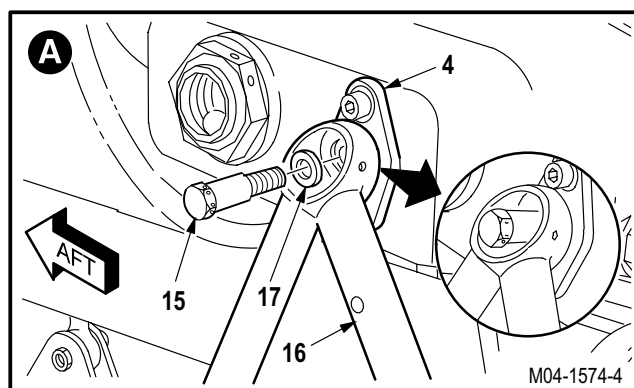

g. Install left truss (18).

- (1) Install two bushings (19) in truss yokes (20).
- (2) Aline truss (18) with fittings (21).
- (3) Install two bolts (22) through fittings (21), bushings (19), and washers (23).
- (4) Install two nuts (24) on bolts (22).
- (5) Aline truss (18) with APU mount (5).
- (6) Install bolt (25) through washer (26) and truss (18) into mount (5).

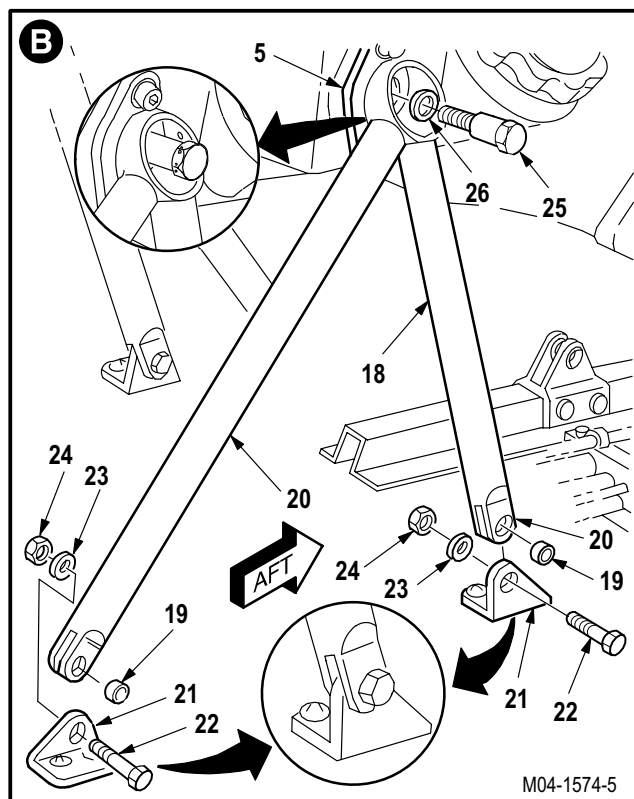

GO TO NEXT PAGE

15.3. APU INSTALLATION - continued

h. Install APU aft mount strut (27).

- (1) Position rod end (28) in fitting (29).
- (2) Install bolt (30) through fitting (29), rod end (28), and bushing (31).
- (3) Install washer (32) and nut (33) on bolt (30). Do not tighten nut (33).
- (4) Position clevis (34) over mount (6).
- (5) Install bolt (35) through clevis (34), mount (6), and bushing (36).
- (6) Install washer (37) and nut (38) on bolt (35). Do not tighten nut (38).
- (7) Tighten nut (33).
- (8) Tighten nut (38).
- (9) Clean the interior of the top hole of the AFT strut. Use metal conditioning compound (item 123A, App F)
- (10) Coat interior of hole with epoxy primer. Use disposable applicator (item 29A, App F) and primer (item 142, App F).
- (11) Insert polyurethane coating (item 141A, App F) in top hole of the strut long enough to be recessed 0.5 inches.
- (12) Apply sealant. Use sealing compound (item 176, App F).

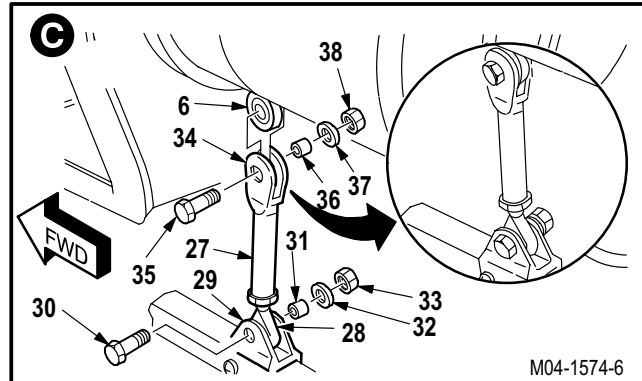

i. Torque right APU mount bolt (15) to 120 INCH-POUNDS. Use torque wrench.

- (1) Lockwire bolt (15) to truss (16). Use wire (item 226, App F).

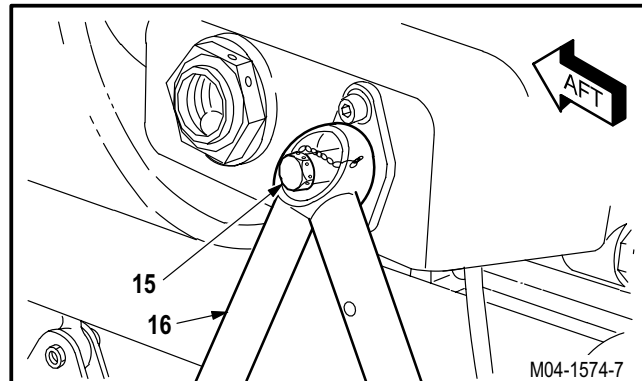

j. Torque left APU mount bolt (25) to 120 INCH-POUNDS. Use torque wrench.

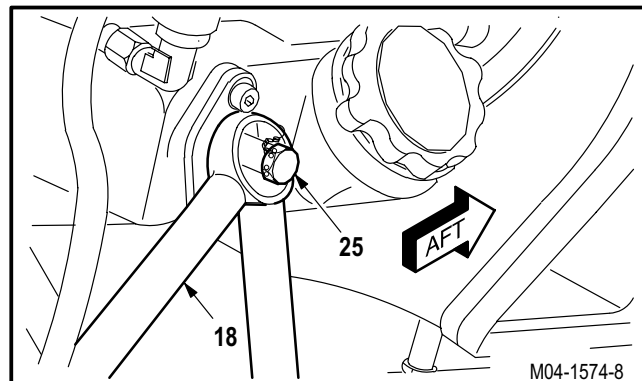

GO TO NEXT PAGE

---

**15.3. APU INSTALLATION - continued**

---

- (1) Lockwire bolt (25) to truss (18). Use wire (item 226, App F).

**k. Remove lifting hook (1) from APU lifting lug (2).**

- (1) Release tension on lifting cable and remove hook (1).

**l. Remove tag lines (12).**

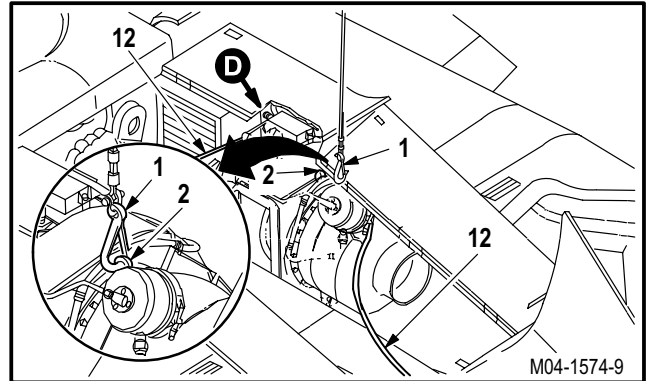

GO TO NEXT PAGE

15.3. APU INSTALLATION - continued



m. Install hydraulic starter pressure hose (39) on nipple (40).

- (1) Lubricate threads of nipple (40). Use hydraulic fluid (item 92, App F).
- (2) Hold nipple (40). Install nut (41). Use open end wrench.

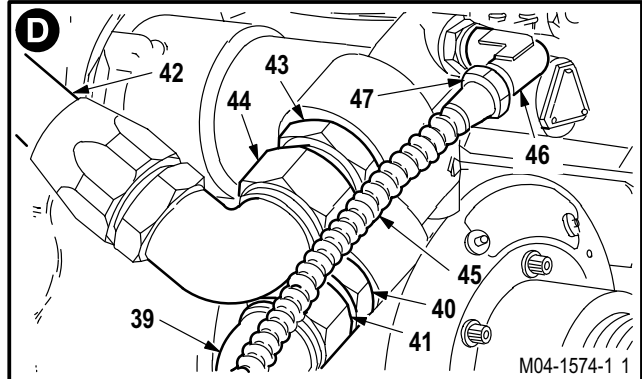

n. Install hydraulic starter return hose (42) on nipple (43).

- (1) Lubricate threads of nipple (43). Use hydraulic fluid (item 92, App F).
- (2) Hold nipple (43). Install nut (44). Use open end wrench.

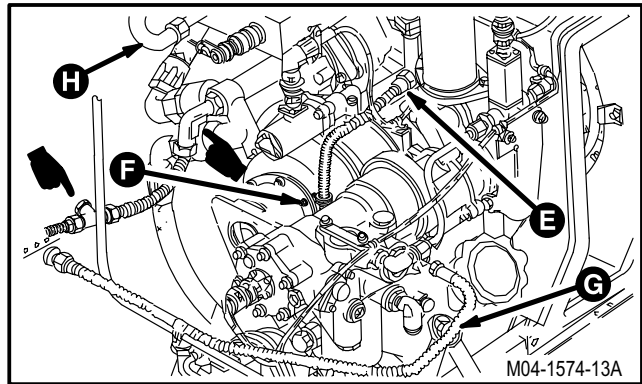

o. Install hydraulic starter drain hose (45) on elbow (46).

- (1) Lubricate threads of elbow (46). Use hydraulic fluid (item 92, App F).
- (2) Hold elbow (46). Install nut (47).

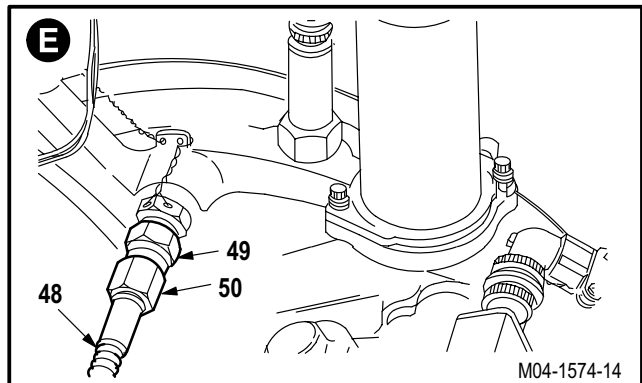

p. Install gearbox vent hose (48) on adapter (49).

- (1) Lubricate threads of adapter (49). Use petrolatum (item 138, App F).
- (2) Hold adapter (49). Install nut (50).

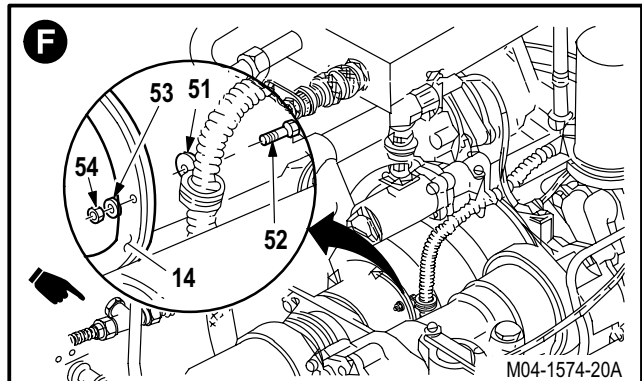

q. Install clamp (51) on PTO clutch (14).

- (1) Insert bolt (52) through clamp (51) and clutch (14).
- (2) Install washer (53) and nut (54).

GO TO NEXT PAGE

**15.3. APU INSTALLATION - continued**

- r. **Install No. 7 drive shaft** (para 6.16).
- s. **Install fuel control drain hose (55) on nipple (56).**
- (1) Lubricate threads of nipple (56). Use petrolatum (item 138, App F).
  - (2) Hold nipple (56). Install nut (57).
- t. **Install fuel supply hose (58) on elbow (59).**
- (1) Lubricate threads of elbow (59). Use petrolatum (item 138, App F).
  - (2) Hold elbow (59). Install nut (60).
- u. **Install two clamps (61).**
- (1) Install clamps (61) on truss (18) and fuel hose (58).
  - (2) Insert screw (62) through washer (63) and clamps (61).
  - (3) Install nut (64).

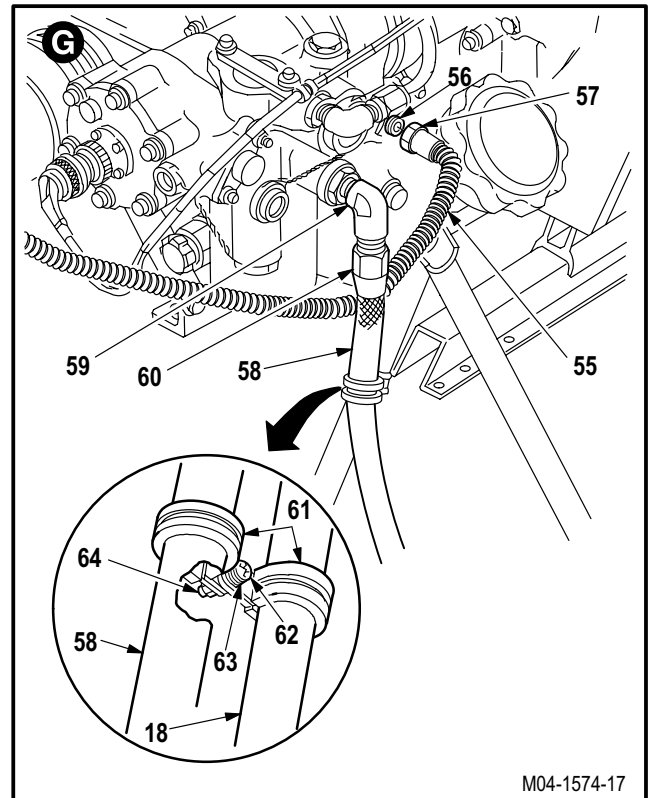

GO TO NEXT PAGE

15.3. APU INSTALLATION - continued



v. **Install APU plenum fuel drain hose (65) on APU fuel drain check valve (66).**

- (1) Lubricate threads of valve (66). Use brush (item 34, App F) and sealing compound (item 177, App F).
- (2) Hold valve (66). Install nut (67).

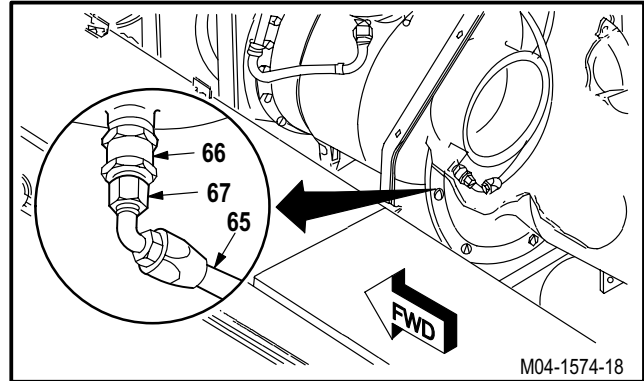

w. **Install clamp (68) on clamp (69).**

- (1) Position clamp (68) on wire harness (70).
- (2) Install screw (71) through clamps (68) and (69).
- (3) Install washer (73) and nut (72) on screw (71).

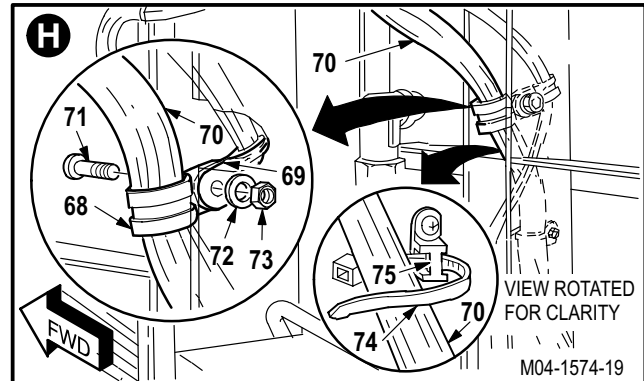

x. **Install two tiedown straps (74) on harness (70).**

- (1) Install two straps (74) through anchors (75) and around harness (70). Use strap (item 192, App F).

y. **Inspect (QA).**

GO TO NEXT PAGE



---

**15.3. APU INSTALLATION - continued**

---

- z. **Remove maintenance crane** (para 1.105).
- aa. **Bleed utility hydraulic system** (para 1.35).
- ab. **Service utility hydraulic system** (para 1.34).
- ac. **Service APU** (para 1.26).
- ad. **Install APU enclosure** (para 15.42).
- ae. **Perform auxiliary power unit maintenance operational check** (TM 1-1520-238-T).

END OF TASK





---

**15.13. APU START/RUN/OFF SWITCH REPLACEMENT**

---

15.13.1. Description

This task covers: Removal. Cleaning. Inspection. Installation.

---

15.13.2. Initial Setup

**Tools:**

Electrical tool kit (item 378, App H)

**References:**

TM 1-1520-238-T

**Personnel Required:**

68X Armament/Electrical System Repairer  
 68X3F Armament/Electrical System Repairer/  
 Technical Inspector

**Equipment Conditions:**

<u>Ref</u>	<u>Condition</u>
1.57	Helicopter safed
12.17	APU fire test panel removed

---

15.13.3. Removal

**a. Remove tee handle (1) and knob (2) from switch shafts (3) and (4).**

- (1) Pull handle (1) to extended position.
- (2) Remove screw (5) from handle (1).
- (3) Pull handle (1) from shaft (3).
- (4) Pull knob (2) from shaft (4).

**b. Remove indicating panel (6).**

- (1) Remove three screws (7).

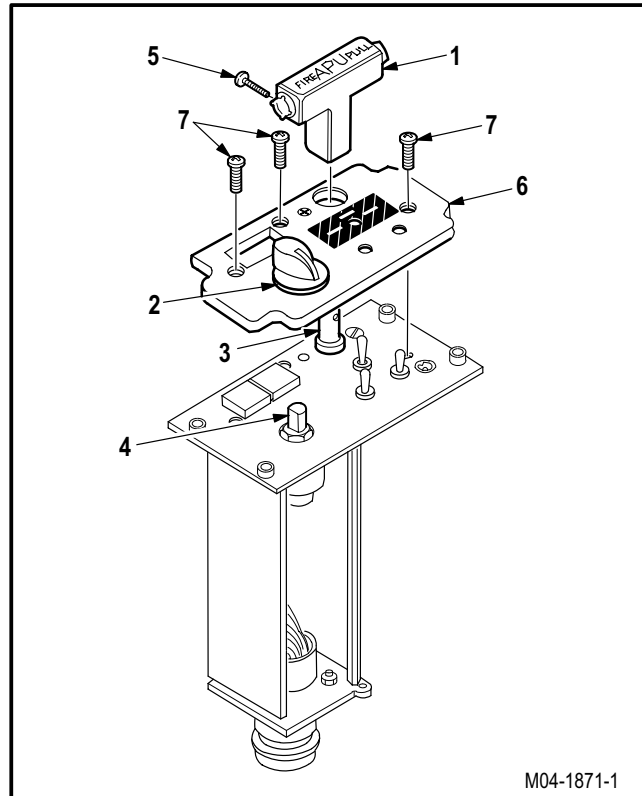

M04-1871-1

GO TO NEXT PAGE

**15.13. APU START/RUN/OFF SWITCH REPLACEMENT - continued**

**c. Remove START/RUN switch (8) from panel (9).**

- (1) Remove nut (10) and lockwasher (11).
- (2) Remove switch (8) from panel (9), locking ring (12), and component board (13).

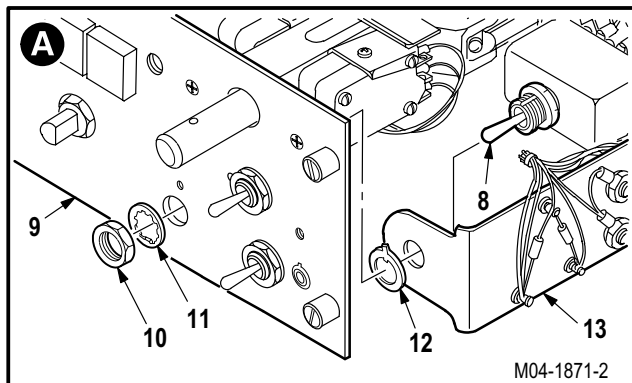

**d. Detach wires (14) from switch (8).**

- (1) Identify wires (14).
- (2) Remove 10 screws (15), lockwashers (16), and lugs (17).
- (3) Discard switch (8).

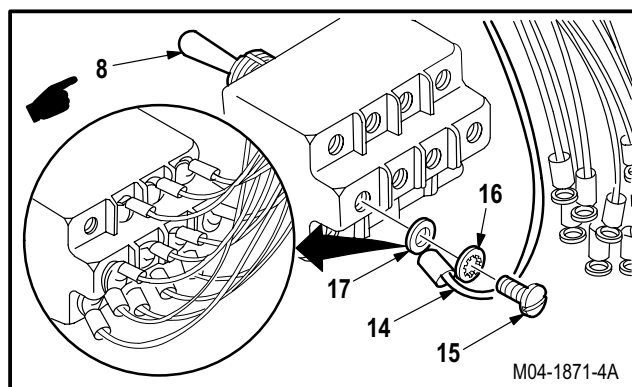

**15.13.4. Cleaning**

- a. **Clean removed and attaching parts** (para 1.47).

**15.13.5. Inspection**

- a. **Check for burned, broken, or frayed wiring or connectors.**
- b. **Check removed and attaching parts for corrosion** (para 1.49).

**15.13.6. Installation**

- a. **Attach identified wires (14) to switch (8).**
  - (1) Install 10 screws (15) through lockwashers (16) and lugs (17).

GO TO NEXT PAGE

**15.13. APU START/RUN/OFF SWITCH REPLACEMENT - continued**

**b. Install switch (8) on panel (9).**

- (1) Install switch (8) through board (13) and lockring (12).
- (2) Install switch (8) in panel (9) so tab (18) on lockring (12) seats in hole (19).
- (3) Install lockwasher (11) and nut (10).

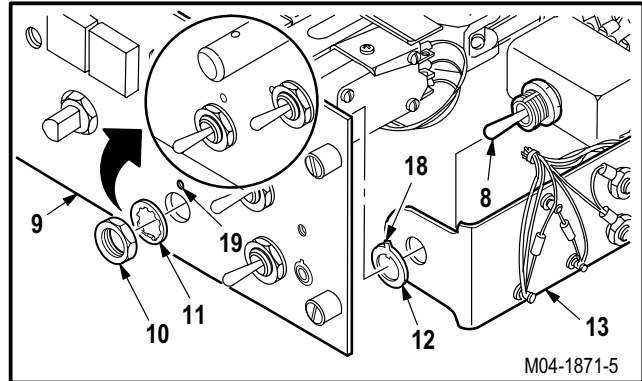

**c. Install panel (6) on panel (9).**

- (1) Install three screws (7).

**d. Install knob (2) on shaft (4).**

**e. Install tee handle (1) on switch shaft (3).**

- (1) Position handle (1) on shaft (3).
- (2) Install screw (5) in handle (1).

**f. Inspect (QA).**

**g. Install APU fire test panel (para 12.17).**

**h. Perform auxiliary power unit maintenance operational check (TM 1-1520-238-T).**

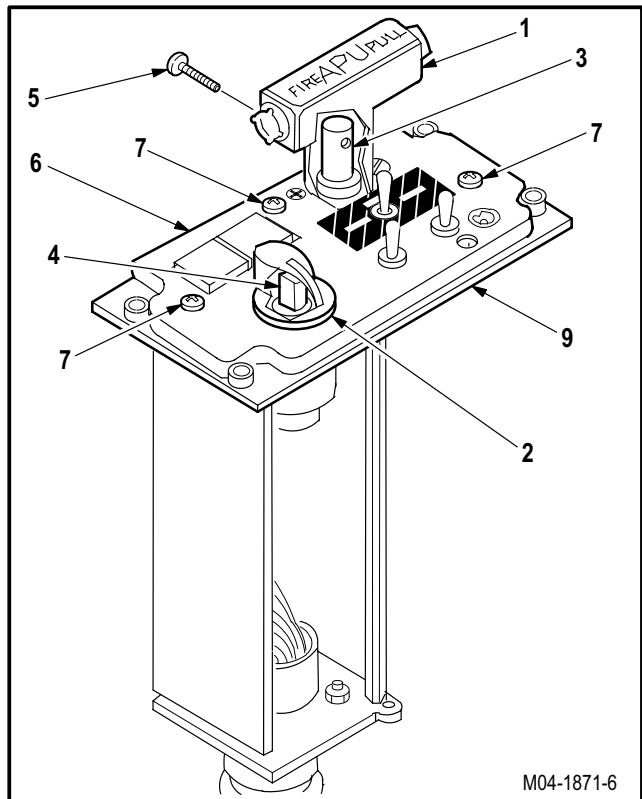

END OF TASK



## 15.20. APU FUEL SUPPLY HOSE REPLACEMENT

### 15.20.1. Description

This task covers: Removal. Cleaning. Inspection. Installation.

### 15.20.2. Initial Setup

#### Tools:

Aircraft mechanic's tool kit (item 376, App H)  
 1 & 1 1/8-inch open end wrench (item 417, App H)

#### Personnel Required:

67R Attack Helicopter Repairer  
 67R3F Attack Helicopter Repairer/Technical Inspector

#### References:

TM 1-1520-238-T

#### Equipment Conditions:

<u>Ref</u>	<u>Condition</u>
1.57	Helicopter safed
15.41	APU enclosure upper center cover removed

**WARNING**

**APU is easy to start. Disconnect battery. Remove all other electrical power before performing any maintenance in this area. Death or serious injury could result if APU starts. If injury occurs, seek medical aid.**

### 15.20.3. Removal

- a. **Enter pilot station (para 1.56). Observe all safety precautions.**
- b. **On pilot center circuit breaker panel, open FUEL APU and APU HOLD circuit breakers.**

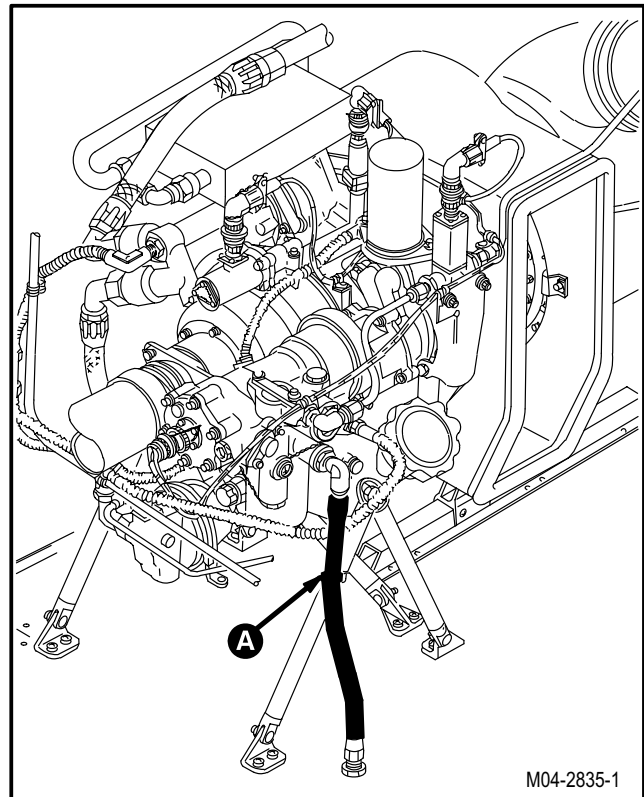

M04-2835-1

GO TO NEXT PAGE



---

**15.20. APU FUEL SUPPLY HOSE REPLACEMENT - continued**

---

**NOTE**

Place rags under work area to catch fuel.

**c. Remove fuel supply hose (1) from APU (2) and aft deck fitting (3).**

(1) Remove clamp (4) from fuel supply hose (1).

(a) Remove nut (5) and washer (6) from screw (7).

(b) Remove screw (7) from clamp (4).

(c) Remove clamp (4) from hose (1).

(2) Remove upper coupling nut (8).

(a) Hold elbow (9). Remove nut (8). Use open end wrench.

(3) Remove lower coupling nut (10).

(a) Hold jam nut (11). Remove nut (10). Use open end wrench.

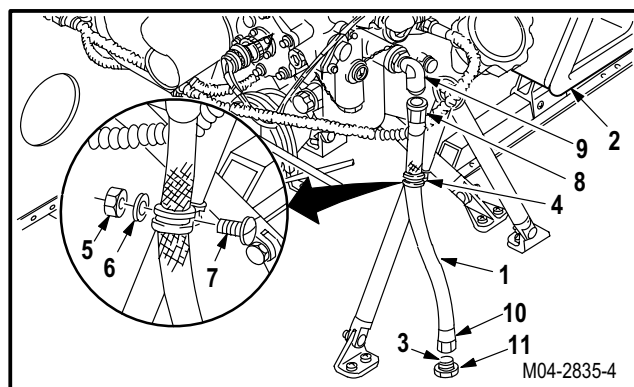

**15.20.4. Cleaning**

a. **Clean removed and attaching parts** (para 1.47).

**15.20.5. Inspection**

a. **Check APU fuel supply hose assembly and mounting elbows for cracks or damaged threads.**

b. **Check removed and attaching parts for corrosion** (para 1.49).

GO TO NEXT PAGE

**15.20. APU FUEL SUPPLY HOSE REPLACEMENT - continued**

15.20.6. Installation

**a. Install fuel supply hose (1) on APU (2) and fitting (3).**

- (1) Install lower end of hose (1) to deck fitting (3).
  - (a) Hold jam nut (11). Install coupling nut (10). Use open end wrench.
- (2) Install upper end of hose (1) to elbow (9).
  - (a) Hold elbow (9). Install coupling nut (8). Use open end wrench.
- (3) Install clamp (4) on hose (1).
  - (a) Install screw (7) through clamp (4).
  - (b) Install washer (6) and nut (5) on screw (7).

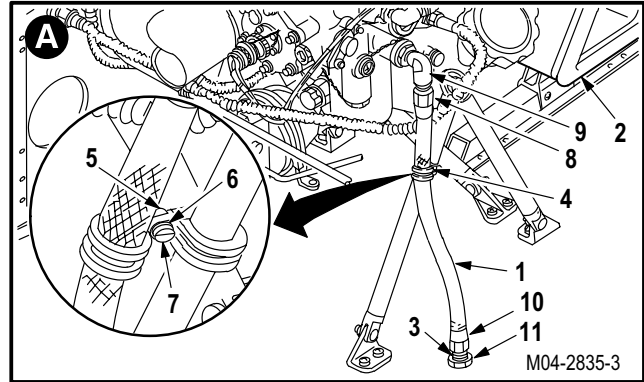

- b. Inspect (QA).**
- c. Install APU enclosure center and forward panels (para 15.42).**
- d. Perform auxiliary power unit maintenance operational check (TM 1-1520-238-T).**

END OF TASK



## 15.23. APU CONTROLLER REMOVAL/INSTALLATION

### 15.23.1. Description

This task covers: Removal. Cleaning. Inspection. Installation.

### 15.23.2. Initial Setup

#### Tools:

Aircraft mechanic's tool kit (item 376, App H)

#### References:

TM 1-1520-238-T

#### Equipment Conditions:

Ref	Condition
1.57	Helicopter safed
2.2	Access doors T250L, T250R, T290L, T290R, and L325 opened

#### Personnel Required:

67R Attack Helicopter Repairer  
 67R3F Attack Helicopter Repairer/Technical Inspector

**WARNING**

**APU is easy to start. Disconnect battery. Remove all other electrical power before performing any maintenance in this area. Death or serious injury could result if APU starts. If injury occurs, seek medical aid.**

### 15.23.3. Removal

- a. Enter pilot station (para 1.56). Observe all safety precautions.
- b. On pilot center circuit breaker panel, open FUEL APU and APU HOLD circuit breakers.
- c. Detach connector P2 (1) from receptacle (A6)J2 (2).
- d. Detach connector P50 (3) from receptacle (A6)J1 (4).

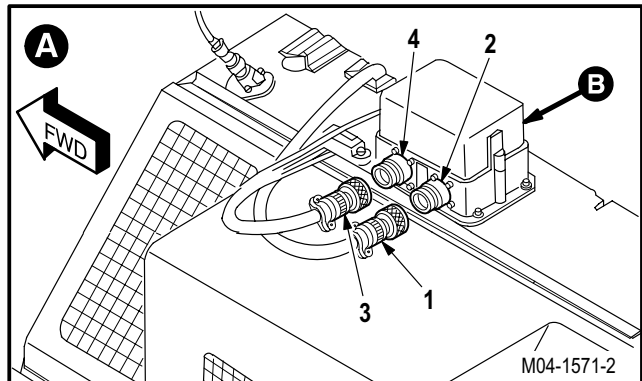
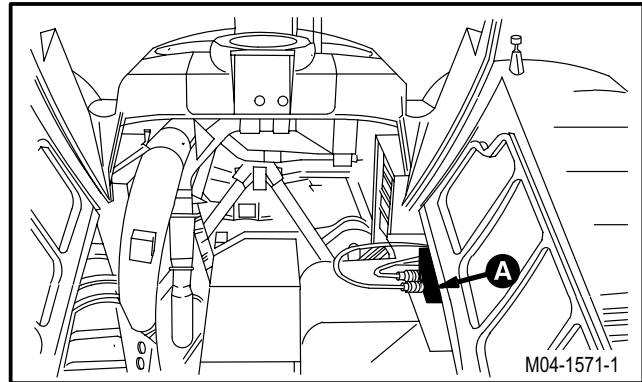

GO TO NEXT PAGE

---

**15.23. APU CONTROLLER REMOVAL/INSTALLATION - continued**

---

**e. Remove bonding lead (5) from APU controller (6).**

- (1) Remove screw (7), lockwasher (8), and washer (9).

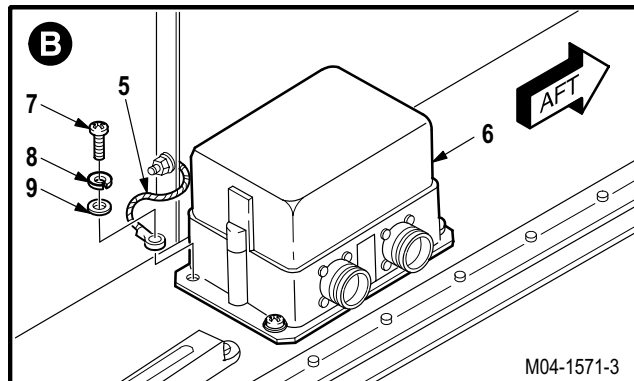
**f. Remove controller (6) from enclosure (10).**

- (1) Remove three screws (11) and washers (12).

**15.23.4. Cleaning**

- a. **Wipe APU enclosure panel with a clean rag.**

**15.23.5. Inspection**

- a. **Check APU controller for burned, bent, or damaged contacts, wiring, or connectors. None allowed.**
- b. **Check removed and attaching parts for corrosion (para 1.49).**

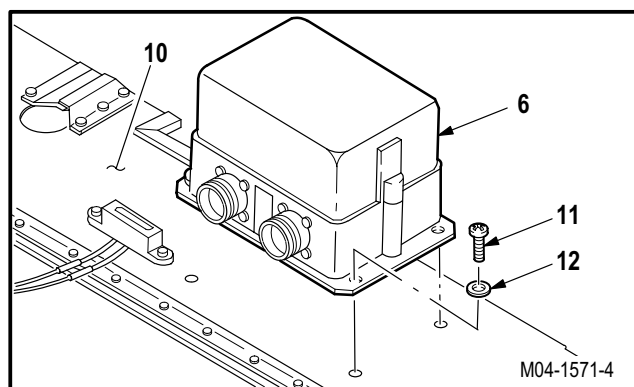

GO TO NEXT PAGE

**15.23. APU CONTROLLER REMOVAL/INSTALLATION - continued**

15.23.6. Installation

**a. Install controller (6) on enclosure (10).**

- (1) Position controller (6) on enclosure (10).
- (2) Install three screws (11) through washers (12) and controller (6) into enclosure (10).
- (3) Install screw (7) through lockwasher (8), washer (9), bonding lead (5), and controller (6) into enclosure (10).

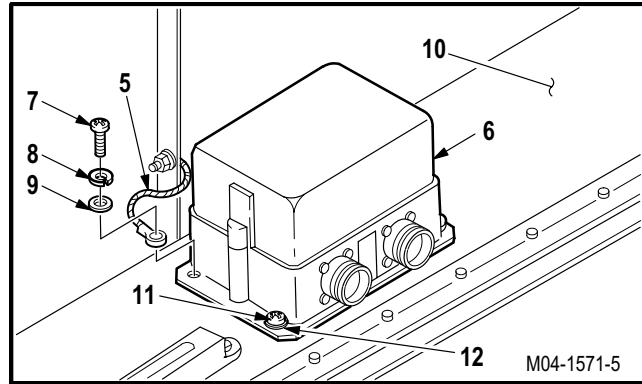

**b. Attach connector P2 (1) to receptacle (A6)J2 (2).**

**c. Attach connector P50 (3) to receptacle (A6)J1 (4).**

**d. Inspect (QA).**

**e. Secure access doors T250L, T250R, T290L, T290R, and L325 (para 2.2).**

**f. Perform auxiliary power unit maintenance operational check (TM 1-1520-238-T).**

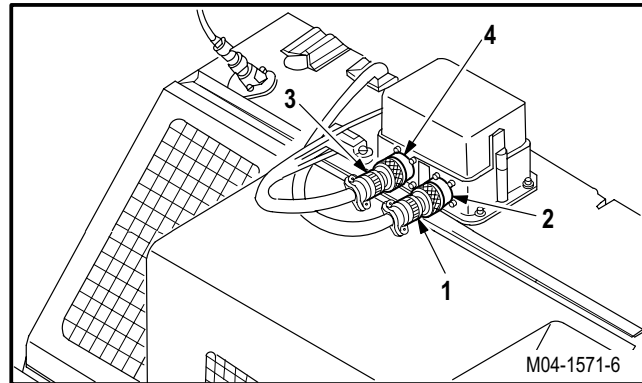

END OF TASK

**15.24. APU TIME TOTALIZING METER REMOVAL/INSTALLATION**

15.24.1. Description

This task covers: Removal. Cleaning. Inspection. Installation.

15.24.2. Initial Setup

**Tools:**

- Aircraft mechanic's tool kit (item 376, App H)
- Electrical tool kit (item 378, App H)
- Electric gun type heater (item 163, App H)

**References:**

- TM 1-1520-238-T
- TM 55-1500-323-24

**Personnel Required:**

- 67R Attack Helicopter Repairer
- 68X Armament/Electrical System Repairer
- 67R3F Attack Helicopter Repairer/Technical Inspector

**Equipment Conditions:**

<u>Ref</u>	<u>Condition</u>
1.57	Helicopter safed
2.2	Access doors T250L, T250R, T290L, T290R, and L325 opened

**NOTE**

This task is typical for present or new type totalizing meter.

15.24.3. Removal

- a. **Enter pilot station** (para 1.56). **Observe all safety precautions.**
- b. **On pilot overhead center circuit breaker panel, open FUEL APU and APU HOLD circuit breakers.**
- c. **Remove time totalizing meter (1) from APU enclosure top cover (2).**

- (1) Identify and depin two splices SP1 and SP2 (3) from wiring harness W102 (4).
- (2) Remove two screws (5) and washers (6).
- (3) Remove meter (1).

15.24.4. Cleaning

- a. **Wipe elapsed time indicator mounting area with a clean rag.**

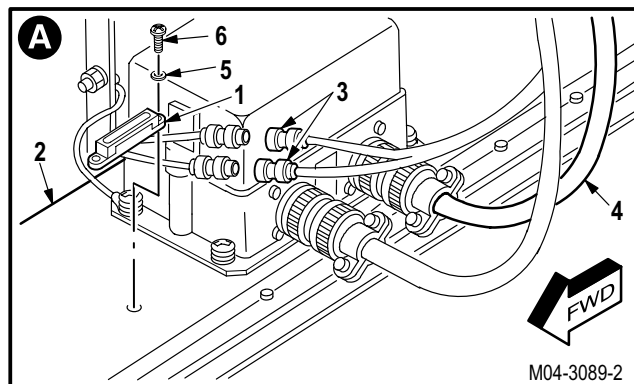
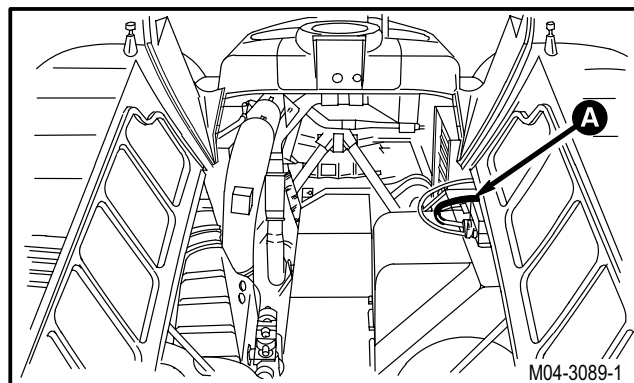

GO TO NEXT PAGE

**15.24. APU TIME TOTALIZING METER REMOVAL/INSTALLATION - continued**

15.24.5. Inspection

- a. **Check time totalizing meter for cracks, frayed or broken wires, and damaged splices** (TM 55-1500-323-24).
- b. **Check removed and attaching parts for corrosion** (para 1.49).

15.24.6. Installation



**WARNING**

**Do not place heater near flammable material or allow heater to contact skin: severe burns can result. Wear protective equipment. If injury occurs, seek medical aid.**

a. **Install meter (1) on cover (2).**

- (1) Position meter (1) on cover (2).
- (2) Install two screws (5) through washers (6) and meter (1) into cover (2).
- (3) Install heat shrink sleeving over wires. Push back out of way to perform next step.
- (4) Pin two splices SP1 and SP2 (3) to harness W102 (4).
- (5) Install heat shrink sleeving over splices and wire. Use heater.

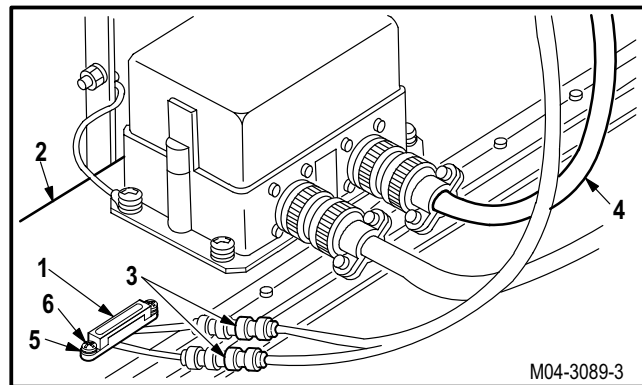

M04-3089-3

b. **Inspect (QA).**

c. **Secure access doors T250L, T250R, T290L, T290R, and L325** (para 2.2).

d. **Perform auxiliary power unit maintenance operational check** (TM 1-1520-238-T).

END OF TASK





## SECTION II. AUXILIARY POWER UNIT MOUNTING AND DRAIN SYSTEM

### 15.31. APU AFT SUPPORT STRUT AND ROD END REMOVAL/INSTALLATION

#### 15.31.1. Description

This task covers: Removal. Cleaning. Inspection. Installation.

#### 15.31.2. Initial Setup

##### Tools:

Aircraft mechanic's tool kit (item 376, App H)

##### Personnel Required:

67R Attack Helicopter Repairer  
 67R3F Attack Helicopter Repairer/Technical Inspector

##### Equipment Conditions:

Ref	Condition
1.57	Helicopter safed
1.97	Maintenance crane installed
1.104	Maintenance crane adjusted - APU
15.41	APU enclosure upper center cover removed

##### References:

TM 55-1500-345-23

**WARNING**

**APU is easy to start. Disconnect battery. Remove all other electrical power before performing any maintenance in this area. Death or serious injury could result if APU starts. If injury occurs, seek medical aid.**

#### 15.31.3. Removal

- a. **Enter pilot station (para 1.56). Observe all safety precautions.**
- b. **On pilot center circuit breaker panel, open FUEL APU and APU HOLD circuit breakers.**

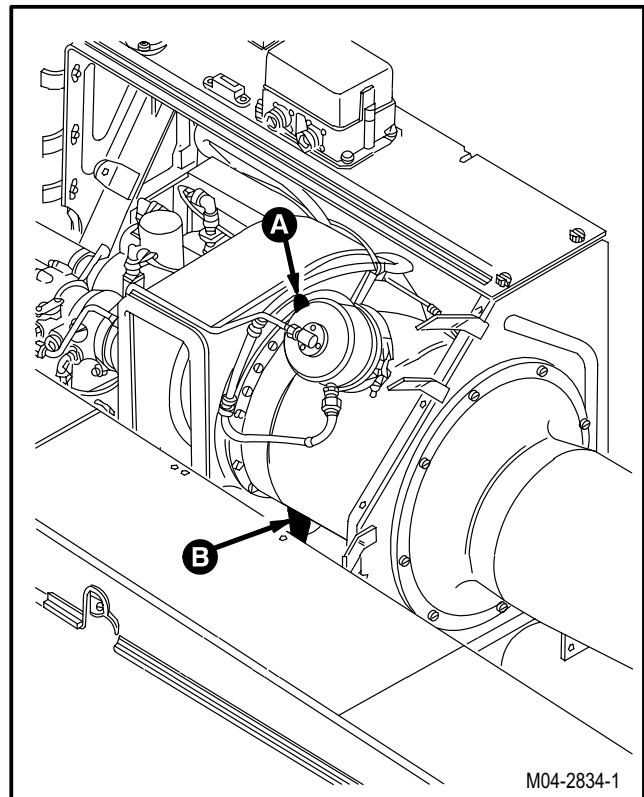

GO TO NEXT PAGE

15.31. APU AFT SUPPORT STRUT AND ROD END REMOVAL/INSTALLATION - continued

**WARNING**

Failure of lifting lug can cause structural damage or injury to personnel. Ensure lifting lug is not bent or cracked. Florescent-penetrant inspect if cracks are suspected. If injury occurs, seek medical aid.

c. Connect maintenance crane lifting hook (1) to APU lifting lug (2).

- (1) Apply tension to cable (3).

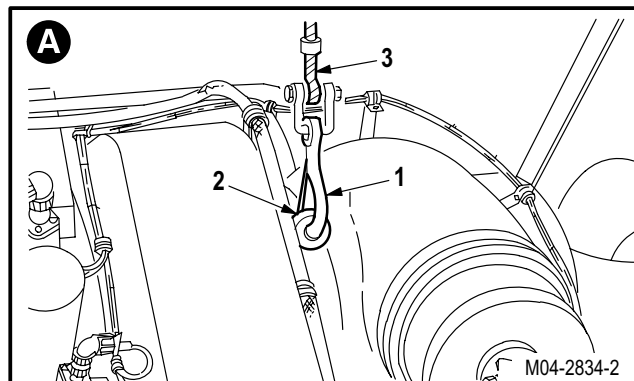

d. Remove clevis end (4) of APU aft support strut (5) from mount (6).

- (1) Remove nut (7) and washer (8) from bolt (9).
- (2) Remove bolt (9) from clevis (4) and mount (6).

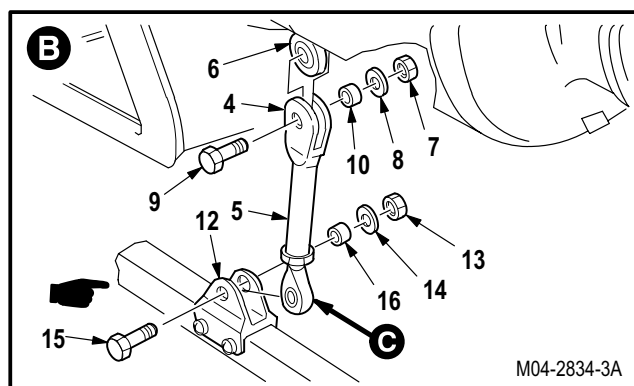

e. Remove rod end (11) of strut (5) from fitting (12).

- (1) Remove nut (13), washer (14) and bushing (16) from bolt (15).
- (2) Remove bolt (15) from rod end (11) and fitting (12).
- (3) Remove support strut (5) from mount (6) and fitting (12).
- (4) Remove split bushing (10) from strut (5).
- (5) Remove split bushing (16) from fitting (12).

f. Remove rod end (11) from strut (5).

- (1) Hold rod end (11) at flats (17).
- (2) Loosen nut (18) and remove rod end (11) from strut (5).
- (3) Remove nut (18).

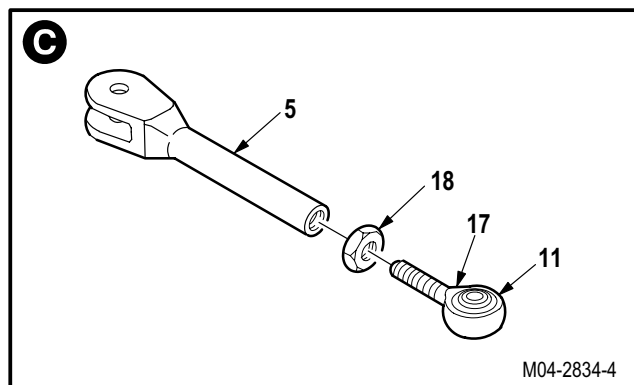

GO TO NEXT PAGE

**15.31. APU AFT SUPPORT STRUT AND ROD END REMOVAL/INSTALLATION - continued**

15.31.4. Cleaning

- a. **Clean removed and attaching parts and surfaces** (para 1.47).

15.31.5. Inspection

- a. **Check support strut for cracks, dents, scratches, elongated holes, and distortion.** Dents and scratches maximum depth **0.010 INCH** must be polished out.
- b. **Check removed and attaching parts and surfaces for corrosion** (para 1.49).

- (1) Clean aft APU strut (para 1.49).
- (2) Blend out corrosion (para 1.49).
- (3) Apply paint finish touch up (TM 55-1500-345-23).



- (4) Apply sealant to tube. Use sealing compound (item 159, App F).

- c. **Check support strut for vertical play.** None allowed.
- d. **Check support strut deck fitting for detectable motion, cracks, elongated holes, and missing hardware** (para 15.35). None allowed.

15.31.6. Installation

- a. **Install rod end (11) on strut (5).**

- (1) Install nut (18) on rod end (11).
- (2) Screw rod end (11) **0.50 INCH** into strut (5).
- (3) Adjust strut (5) to **5.35 INCHES** between bolt hole centers.
- (4) Aline rod end (11) with clevis (4).
- (5) Hold rod end (11) at flats (17). Tighten nut (18).

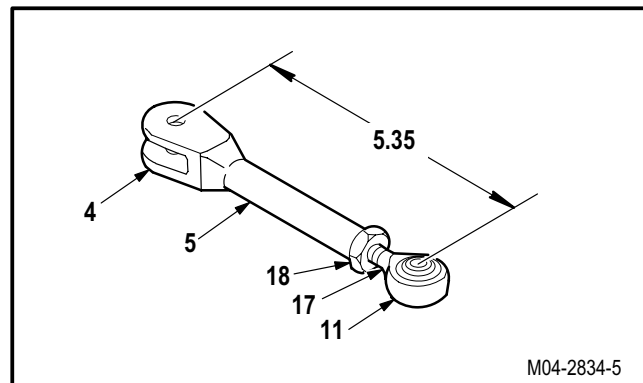

M04-2834-5

GO TO NEXT PAGE

**15.31. APU AFT SUPPORT STRUT AND ROD END REMOVAL/INSTALLATION - continued****b. Install rod end (11) on fitting (12).**

- (1) Position rod end (11) in fitting (12).
- (2) Install bolt (15) through fitting (12), rod end (11), fitting (12), and bushing (16).
- (3) Install washer (14) and nut (13) on bolt (15). Do not tighten nut (13).

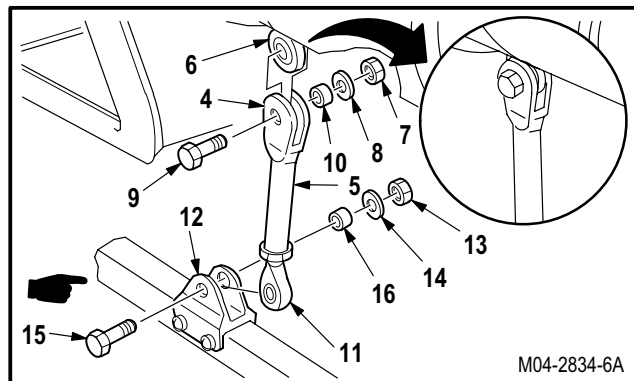
**c. Install clevis (4) on mount (6).**

- (1) Position clevis (4) over mount (6).
- (2) Install bolt (9) through clevis (4), mount (6), clevis (4), and bushing (10).
- (3) Install washer (8) and nut (7) on bolt (9). Do not tighten nut (7).

**d. Hold bolt (15). Tighten nut (13).****e. Hold bolt (9). Tighten nut (7).****f. Release tension on cable (3).**

- (1) Remove hook (1) from lug (2).

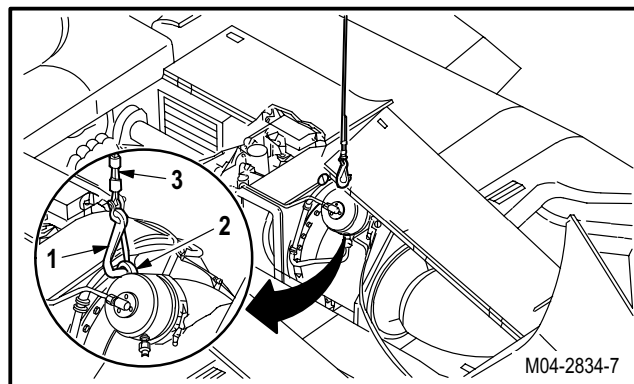
**g. Inspect (QA).****h. Remove maintenance crane (para 1.105).****i. Install APU enclosure upper center panel (para 15.42).**

END OF TASK

---

## 15.32. RIGHT TRUSS REMOVAL/INSTALLATION

---

### 15.32.1. Description

This task covers: Removal. Cleaning. Inspection. Installation.

---

### 15.32.2. Initial Setup

#### Tools:

Aircraft mechanic's tool kit (item 376, App H)

#### References:

■ TM 55-1500-335-23

#### Personnel Required:

67R Attack Helicopter Repairer  
67R3F Attack Helicopter Repairer/Technical  
Inspector

#### Equipment Conditions:

<u>Ref</u>	<u>Condition</u>
1.57	Helicopter safed
15.2	APU removed

---

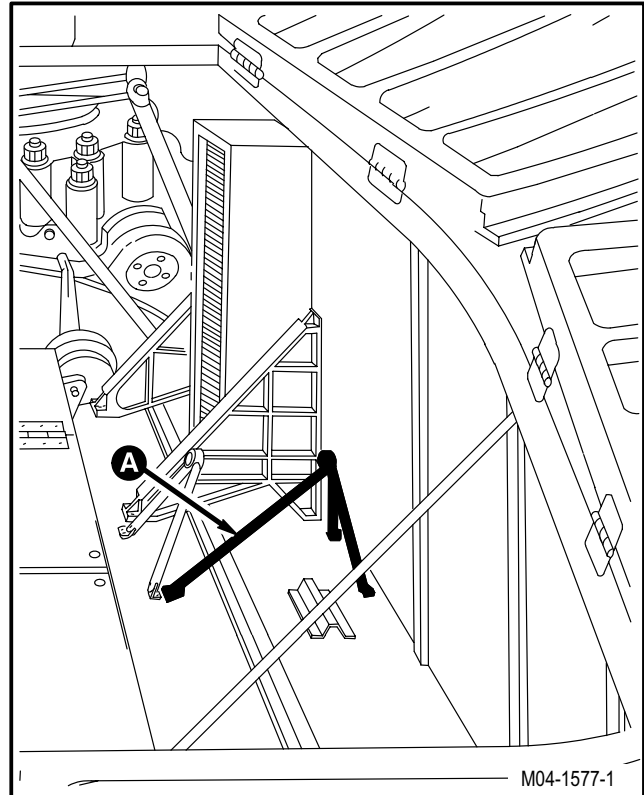

GO TO NEXT PAGE

---

**15.32. RIGHT TRUSS REMOVAL/INSTALLATION - continued**

---

**15.32.3. Removal****a. Remove truss (1) from fittings (2).**

- (1) Hold three bolts (3). Remove three nuts (4) and washers (5).
- (2) Remove three bolts (3) from truss (1) and fittings (2).
- (3) Remove truss (1).

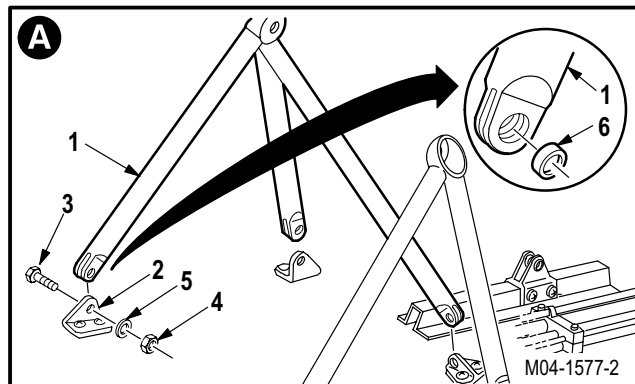
**b. Remove three bushings (6) from truss (1).****15.32.4. Cleaning****a. Clean removed and attaching parts (para 1.47).****15.32.5. Inspection****a. Check APU support strut and truss assemblies for cracks, dents, scratches, distortion, loose bolts, and elongated holes.**

- (1) Fluorescent-penetrant inspect if cracks are suspected (TM 55-1500-335-23). Replace if cracks are found.
- (2) Scratches **0.010 INCH** maximum must be blended out. Replace if scratches are deeper than **0.010 INCH**.
- (3) Dents shall not exceed **0.010 INCH** and must be blended out. Replace if dents are deeper than **0.010 INCH**.
- (4) Check the entire length of each weld line for cracks and any other abnormalities. Use inspection mirror as required.

**b. Check removed and attaching parts for corrosion (para 1.49).****c. Check bushings for elongation and galling. None allowed.****d. Check the APU support deck fittings for detectable motion, cracks, elongated holes, and missing hardware (para 15.34). None allowed.**

GO TO NEXT PAGE

---

**15.32. RIGHT TRUSS REMOVAL/INSTALLATION - continued**

---

15.32.6. Installation

a. **Install three bushings (6) in truss assembly (1).**

b. **Install truss (1) on fittings (2).**

- (1) Position truss (1) on three fittings (2).
- (2) Install three bolts (3) through truss (1) and three fittings (2).
- (3) Install three washers (5) and nuts (4) on bolts (3).

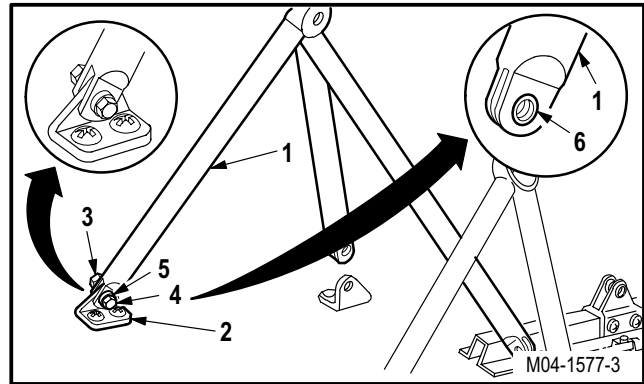

c. **Inspect (QA).**

d. **Install APU** (para 15.3).

END OF TASK



**15.33. LEFT TRUSS REMOVAL/INSTALLATION**

xs

15.33.1. Description

This task covers: Removal. Cleaning. Inspection. Installation.

15.33.2. Initial Setup

**Tools:**

Aircraft mechanic's tool kit (item 376, App H)

**References:**

■ TM 55-1500-335-23

**Personnel Required:**

67R Attack Helicopter Repairer  
 67R3F Attack Helicopter Repairer/Technical Inspector

**Equipment Conditions:**

<u>Ref</u>	<u>Condition</u>
1.57	Helicopter safed
15.2	APU removed

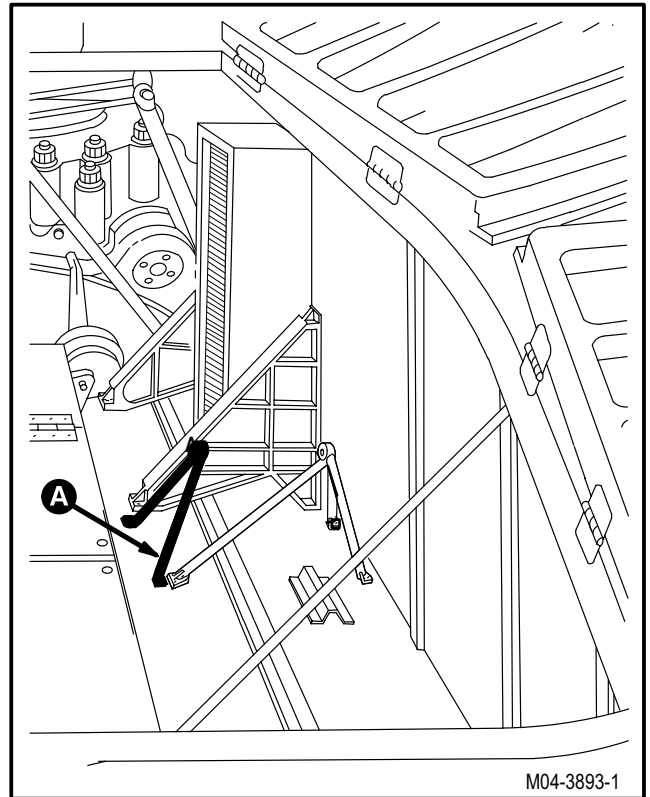

GO TO NEXT PAGE

**15.33. LEFT TRUSS REMOVAL/INSTALLATION - continued**

15.33.3. Removal

a. **Remove truss assembly (1) from fittings (2).**

- (1) Hold two bolts (3). Remove two nuts (4) and washers (5).
- (2) Remove two bolts (3) from truss (1) and fittings (2).
- (3) Remove truss (1).

b. **Remove two bushings (6) from truss (1).**

15.33.4. Cleaning

a. **Clean removed and attaching parts** (para 1.47).

15.33.5. Inspection

a. **Check APU support strut and truss assemblies for cracks, dents, scratches, distortion, loose bolts, and elongated holes.**

- (1) Fluorescent-penetrant inspect if cracks are suspected (TM 55-1500-335-23). Replace if cracks are found.
- (2) Scratches **0.010 INCH** maximum must be blended out. Replace if scratches are deeper than **0.010 INCH**.
- (3) Dents shall not exceed **0.010 INCH** and must be blended out. Replace if dents are deeper than **0.010 INCH**.
- (4) Check the entire length of each weld line for cracks and any other abnormalities. Use inspection mirror as required.

b. **Check removed and attaching parts for corrosion** (para 1.49).

c. **Check bushings for elongation and galling.** None allowed.

d. **Check the APU support deck fittings for detectable motion, cracks, elongated holes, and missing hardware** (para 15.34). None allowed.

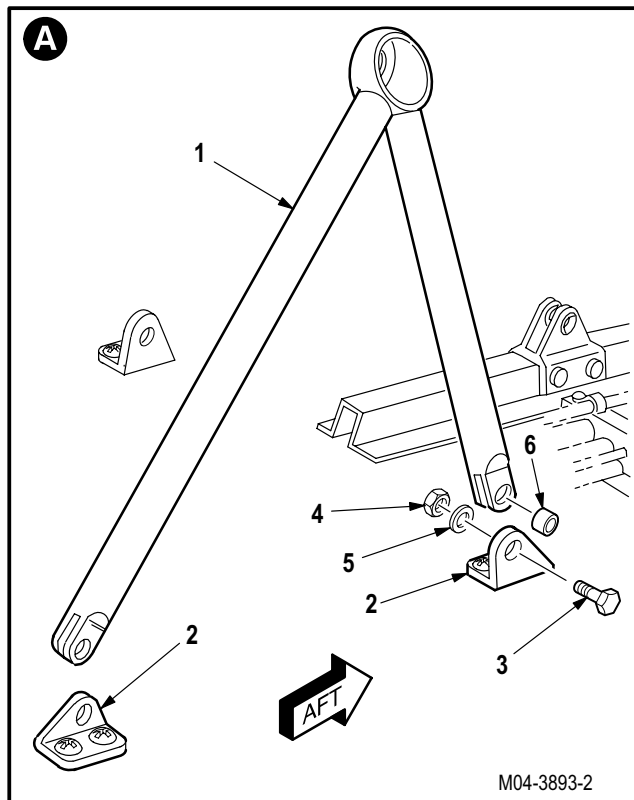

GO TO NEXT PAGE

**15.33. LEFT TRUSS REMOVAL/INSTALLATION - continued**15.33.6. Installation

a. **Install two bushings (6) in truss assembly (1).**

b. **Install truss (1) on fittings (2).**

(1) Position truss (1) on two fittings (2).

(2) Install two bolts (3) through truss (1) and two fittings (2).

(3) Install two washers (5) and nuts (4) on bolts (3).

c. **Inspect (QA).**

d. **Install APU (para 15.3).**

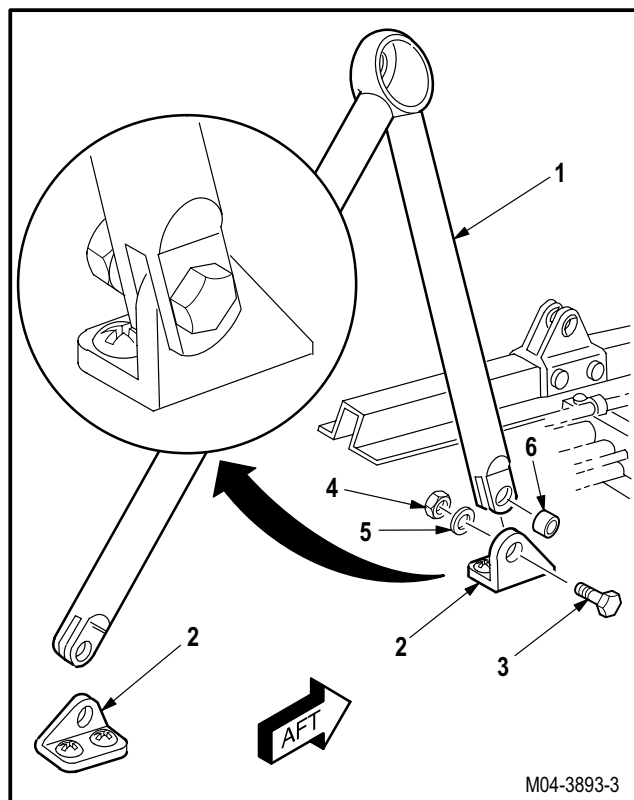

END OF TASK

**15.34. APU SUPPORT DECK FITTING REMOVAL/INSTALLATION**

15.34.1. Description

This task covers: Removal. Cleaning. Inspection. Installation.

15.34.2. Initial Setup

**Tools:**

Aircraft mechanic's tool kit (item 376, App H)

**Personnel Required:**

67R Attack Helicopter Repairer  
 67R3F Attack Helicopter Repairer/Technical Inspector

**Equipment Conditions:**

<u>Ref</u>	<u>Condition</u>
1.57	Helicopter safed
15.2	APU assembly removed
15.32	Right truss removed or
15.33	Left truss removed

15.34.3. Removal

**NOTE**

- APU support deck fittings are not alike. If more than one is to be removed, identify location for installation.
- Removal and installation are typical for all five fittings, except as noted.

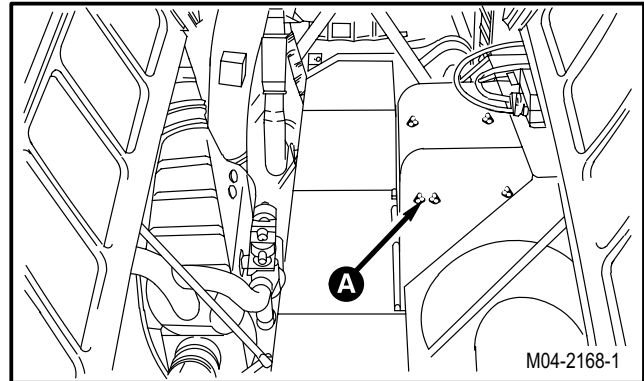

a. **Remove support deck fitting (1) from support deck (2).**

(1) Remove two screws (3) and washers (4).

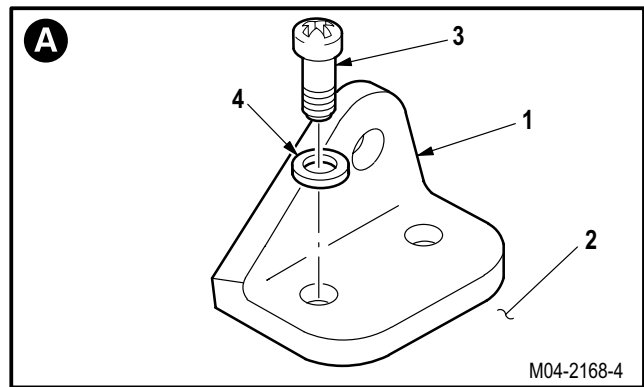

15.34.4. Cleaning

a. **Clean removed and attaching parts and surfaces** (para 1.47).

GO TO NEXT PAGE

---

**15.34. APU SUPPORT DECK FITTING REMOVAL/INSTALLATION - continued**

---

15.34.5. Inspection

- a. **Check fittings for cracks and security of attachment** (para 15.1).
- b. **Check removed and attaching parts and surfaces for corrosion** (para 1.49).
- c. **Check fittings for detectable motion, elongated holes, and missing hardware.** None allowed.

15.34.6. Installation**NOTE**

If more than one support fitting has been removed, determine position from identification mark.

a. **Install fitting (1) on deck (2).**

- (1) Position fitting (1) on bolt holes.
- (2) Install two screws (3) through washers (4) and fitting (1) into deck (2).

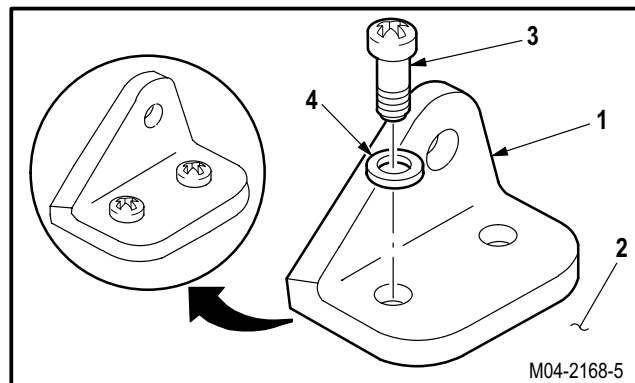
b. **Inspect (QA).**c. **Install right truss** (para 15.32) **or left truss** (para 15.33).d. **Install APU** (para 15.3).

END OF TASK

## 15.35. APU AFT FITTING REMOVAL/INSTALLATION

### 15.35.1. Description

This task covers: Removal. Cleaning. Inspection. Installation.

### 15.35.2. Initial Setup

#### Tools:

Aircraft mechanic's tool kit (item 376, App H)

#### Personnel Required:

67R Attack Helicopter Repairer  
 67R3F Attack Helicopter Repairer/Technical Inspector

#### Equipment Conditions:

<u>Ref</u>	<u>Condition</u>
1.57	Helicopter safed
15.2	APU removed
15.31	Aft support strut removed

### 15.35.3. Removal

#### a. Remove APU aft fitting (1) from support (2).

- (1) Hold two screws (3). Remove nuts (4) and washers (5).
- (2) Remove two screws (3) from fitting (1) and support (2).
- (3) Remove fitting (1) and shims (6) from support (2).

### 15.35.4. Cleaning

#### a. Clean removed and attaching parts and surfaces (para 1.47).

### 15.35.5. Inspection

- a. Check fitting for cracks and security of attachment (para 15.1).
- b. Check removed and attaching parts and surfaces for corrosion (para 1.49).
- c. Check mount fitting for dings and scratches. Dings and scratches maximum depth **0.015 INCH** must be polished out.
- d. Check fittings for detectable motion, elongated holes, and missing hardware. None allowed.

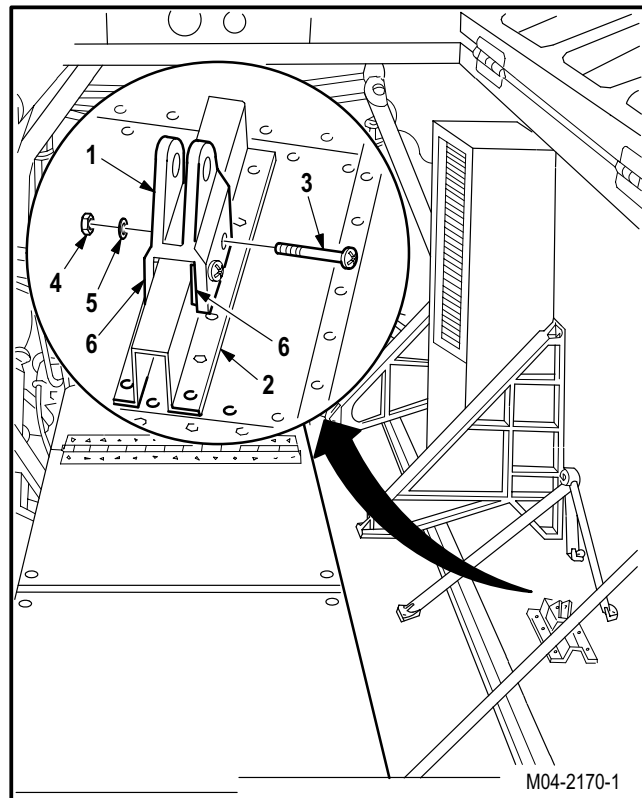

GO TO NEXT PAGE

---

**15.35. APU AFT FITTING REMOVAL/INSTALLATION - continued**

---

**15.35.6. Installation****NOTE**

Place shims equally at four places on each side of fitting to provide a maximum gap of **0.002 INCH**.

**a. Install fitting (1) on support (2).**

- (1) Position fitting (1) on support (2).
- (2) Install shims (6) between fitting (1) and support (2) as necessary.
- (3) Install two screws (3) through fitting (1) and support (2).
- (4) Install two washers (5) and nuts (4) on screws (3).

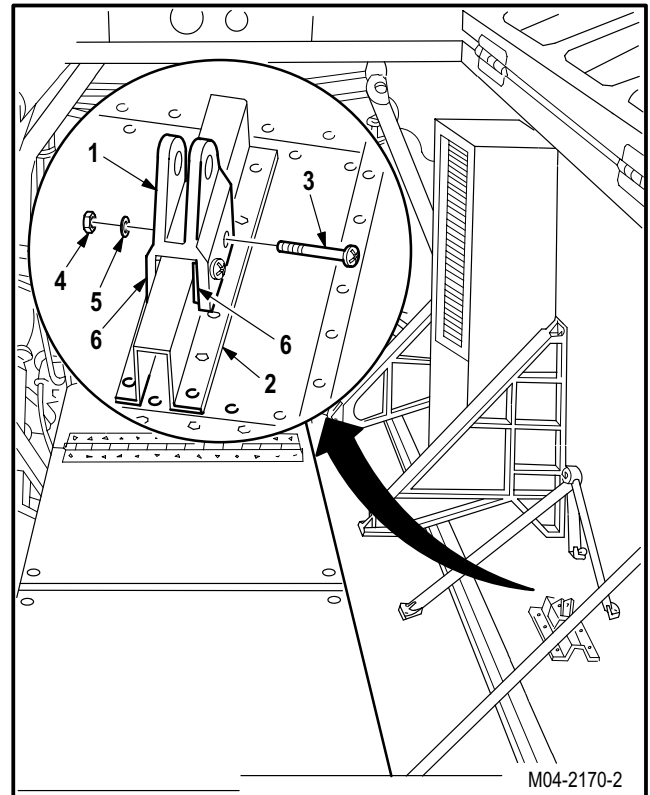
**b. Inspect (QA).****c. Install aft support strut (para 15.31).****d. Install APU (para 15.3).**

END OF TASK

---

## 15.36. APU FORWARD LEFT OR RIGHT MOUNT FITTING REPLACEMENT

---

### 15.36.1. Description

This task covers: Removal. Cleaning. Inspection. Installation.

---

### 15.36.2. Initial Setup

#### Tools:

Aircraft mechanic's tool kit (item 376, App H)

#### References:

TM 55-1500-322-24

#### Materials/Parts:

Wire (item 226, App F)

#### Equipment Conditions:

#### Personnel Required:

67R Attack Helicopter Repairer  
67R3F Attack Helicopter Repairer/Technical  
Inspector

<u>Ref</u>	<u>Condition</u>
1.57	Helicopter safed
1.97	Maintenance crane installed
15.2	APU removed

---

### NOTE

This task is typical for forward left and right mount fittings.

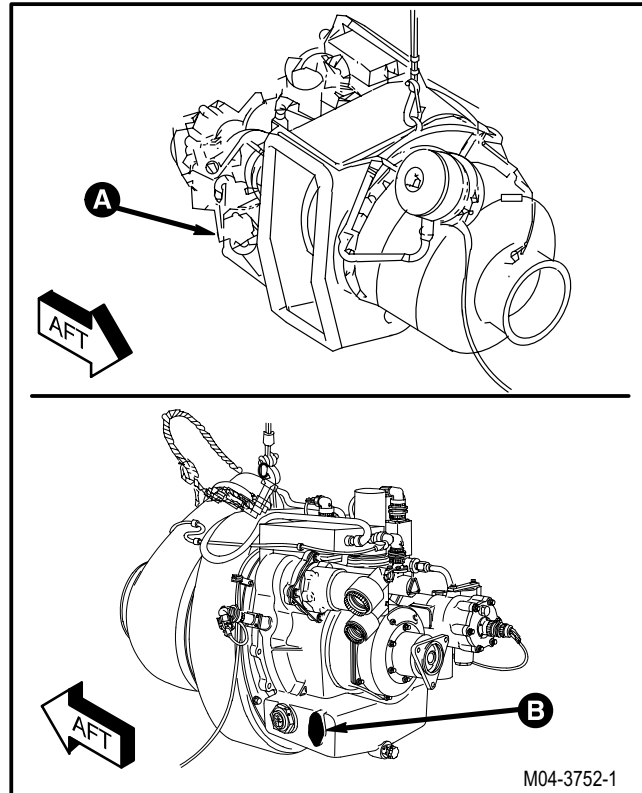

GO TO NEXT PAGE



**15.36. APU FORWARD LEFT OR RIGHT MOUNT FITTING REPLACEMENT - continued**

15.36.3. Removal

a. **Remove left or right mount fitting (1).**

- (1) Remove lockwire from two bolts (2).
- (2) Remove two bolts (2), washers (3), and fitting (1) from APU (4).

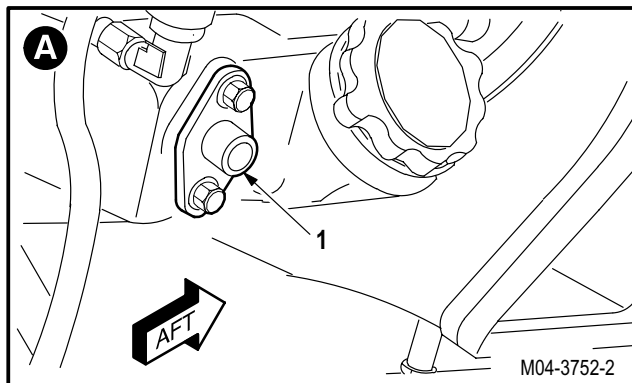

15.36.4. Cleaning

a. **Clean removed and attaching parts and surfaces (para 1.47).**

15.36.5. Inspection

- a. **Check APU aft support strut and truss assemblies for cracks, dents, and scratches (para 15.1).**
- b. **Check aft strut mount rod end for wear (TM 55-1500-322-24).**
- c. **Check APU exhaust nozzle for cracks or heat discoloration (para 15.1).**
- d. **Check removed and attaching parts and surfaces for corrosion (para 1.49).**

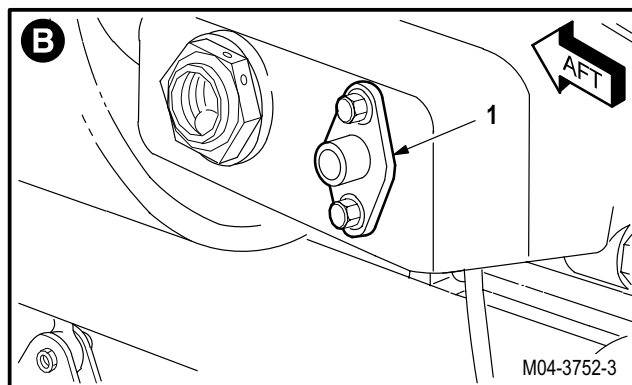

15.36.6. Installation

a. **Install left or right fitting (1).**

- (1) Install two bolts (2) through washers (3) and fitting (1) into APU (4).

b. **Lockwire two bolts (2) together.** Use wire (item 226, App F).

c. **Inspect (QA).**

d. **Install APU (para 15.3).**

e. **Remove maintenance crane (para 1.105).**

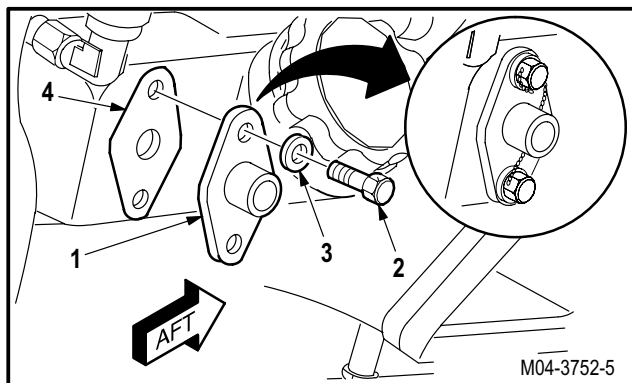
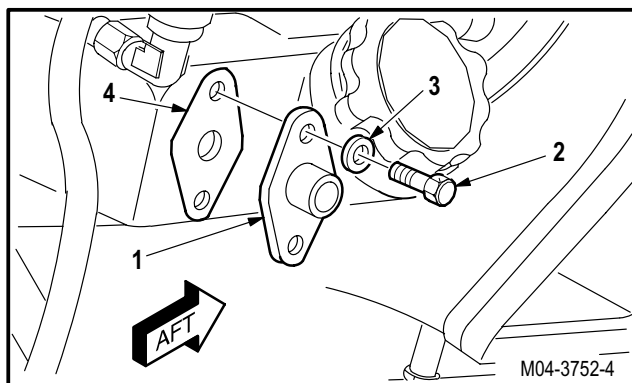

END OF TASK

---

## 15.37. APU PLENUM DRAIN HOSE REPLACEMENT

---

### 15.37.1. Description

This task covers: Removal. Cleaning. Inspection. Installation.

---

### 15.37.2. Initial Setup

#### Tools:

Aircraft mechanic's tool kit (item 376, App H)  
 Light duty laboratory apron (item 27, App H)  
 Chemical protective gloves (item 154, App H)  
 Adjustable air filtering respirator (item 262, App H)

#### Equipment Conditions:

<u>Ref</u>	<u>Condition</u>
1.57	Helicopter safed
15.41	APU enclosure upper center cover removed

#### Personnel Required:

67R Attack Helicopter Repairer  
 67R3F Attack Helicopter Repairer/Technical Inspector

---

**WARNING**

**APU is easy to start. Disconnect battery. Remove all other electrical power before performing any maintenance in this area. Death or serious injury could result if APU starts. If injury occurs, seek medical aid.**

### 15.37.3. Removal

- a. **Enter pilot station (para 1.56). Observe all safety precautions.**
- b. **On pilot center circuit breaker panel, open FUEL APU and APU HOLD circuit breakers.**

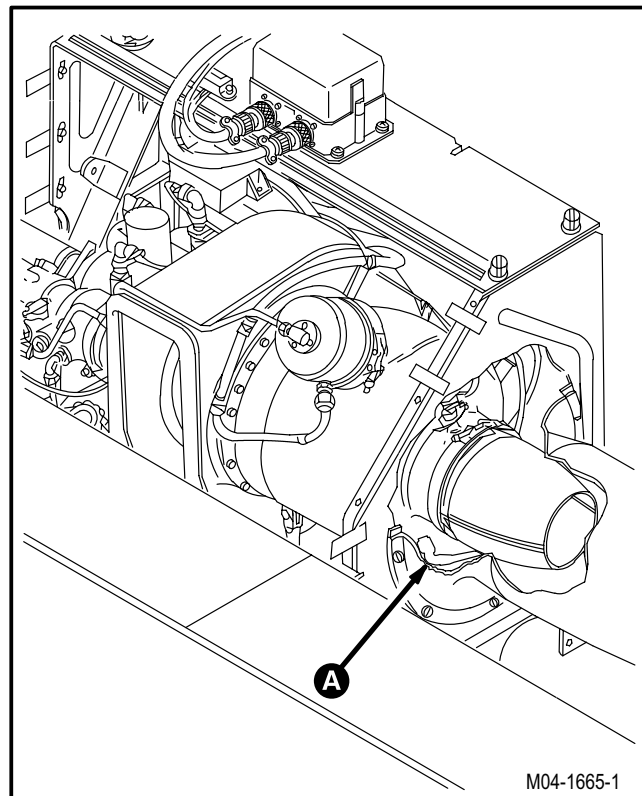

GO TO NEXT PAGE

---

**15.37. APU PLENUM DRAIN HOSE REPLACEMENT - continued**

---

**NOTE**

Place rags under work area to catch fuel.

**c. Remove drain hose (1) from check valve (2) and fitting (3).**

(1) Hold valve (2). Remove nut (4).

(2) Hold fitting (3). Remove nut (5).

(3) Remove drain hose (1).

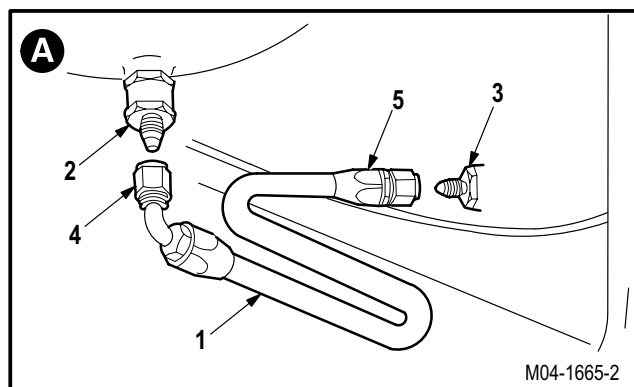

**15.37.4. Cleaning**

**a. Clean removed and attaching parts (para 1.47).**

**15.37.5. Inspection**

**a. Check APU plenum drain hose and connecting hardware for cracks and damaged threads. None allowed.**

**b. Check removed and attaching parts for corrosion (para 1.49).**

**15.37.6. Installation**

**a. Install new hose (1) on fitting (3) and valve (2).**

(1) Hold fitting (3). Install nut (5).

(2) Hold valve (2). Install nut (4).

**b. Inspect (QA).**

**c. Install APU enclosure upper center cover (para 15.42).**

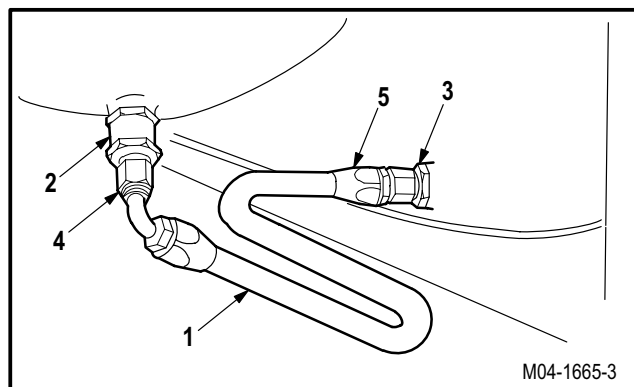

END OF TASK

**15.38. APU HYDRAULIC DRAIN HOSE REMOVAL/INSTALLATION**

15.38.1. Description

This task covers: Removal. Cleaning. Inspection. Installation.

15.38.2. Initial Setup

**Tools:**

- Aircraft mechanic's tool kit (item 376, App H)
- Light duty laboratory apron (item 27, App H)
- Chemical protective gloves (item 154, App H)
- Adjustable air filtering respirator (item 262, App H)
- 0 - 30 inch-pound 1/4-inch drive dial indicator torque wrench (item 445, App H)

**Materials/Parts:**

- Packing (2)
- Hydraulic fluid (item 92, App F)
- Petrolatum (item 138, App F)
- Wire (item 226, App F)

**Personnel Required:**

- 67R Attack Helicopter Repairer
- 67R3F Attack Helicopter Repairer/Technical Inspector

**Equipment Conditions:**

<u>Ref</u>	<u>Condition</u>
1.57	Helicopter safed
15.41	APU enclosure upper center cover removed



**APU is easy to start. Disconnect battery. Remove all other electrical power before performing any maintenance in this area. Death or serious injury could result if APU starts. If injury occurs, seek medical aid.**

15.38.3. Removal

- a. **Enter pilot station (para 1.56). Observe all safety precautions.**
- b. **On pilot center circuit breaker panel, open FUEL APU and APU HOLD circuit breakers.**

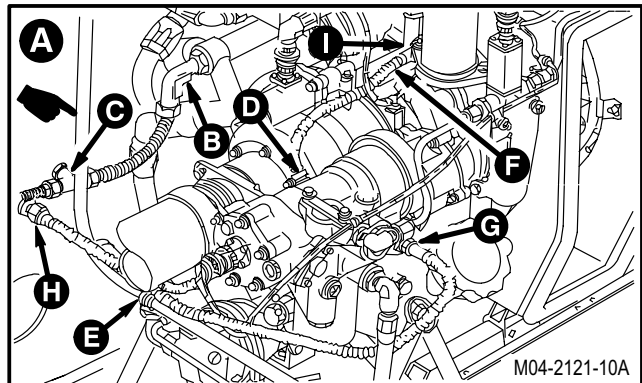
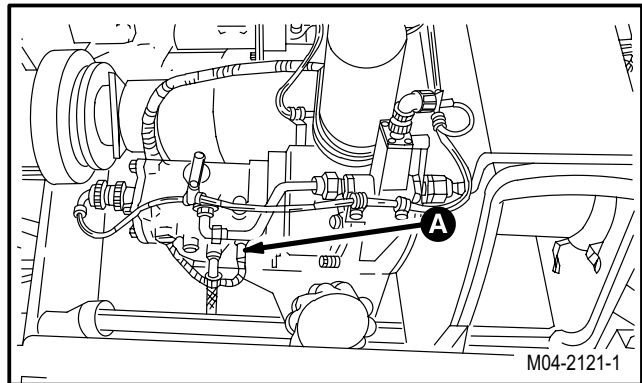

GO TO NEXT PAGE

---

**15.38. APU HYDRAULIC DRAIN HOSE REMOVAL/INSTALLATION - continued**

---

**NOTE**

Place rags under work area to catch fuel.

**c. Remove hose (1).**

- (1) Hold elbow (2). Remove nut (3).
- (2) Hold tee (4). Remove nut (5).
- (3) Remove hose (1).

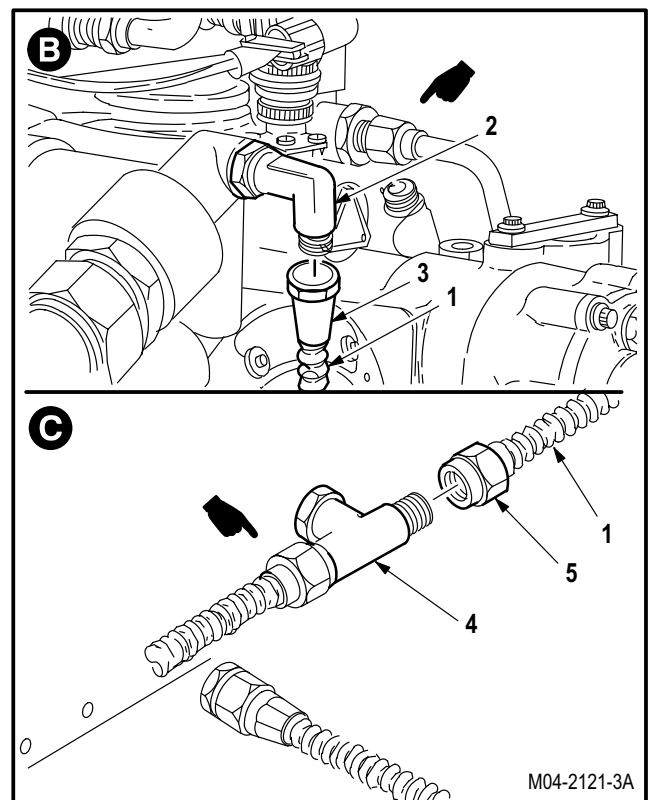

GO TO NEXT PAGE

**15.38. APU HYDRAULIC DRAIN HOSE REMOVAL/INSTALLATION - continued**

**d. Remove clamp (6) from PTO clutch (7).**

- (1) Remove nut (8) from bolt (9).
- (2) Remove bolt (9) and washer (10) from clamp (6) and clutch (7).
- (3) Remove clamp (6) from gearbox vent hose (11).

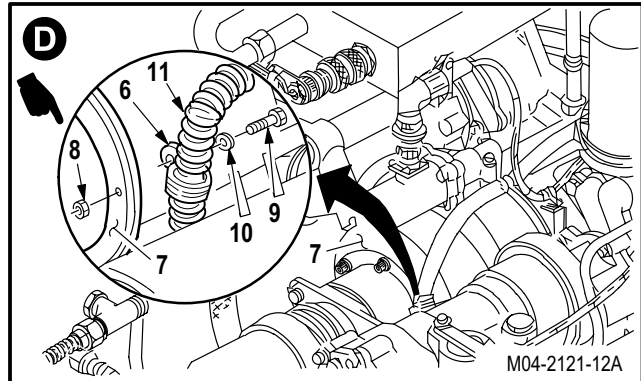

**e. Remove clamps (12) and (13) from clamp (14).**

- (1) Remove nut (15) and washer (16) from screw (17).
- (2) Remove clamp (12) from hose (11).
- (3) Remove clamp (13) from fuel control drain hose (18).

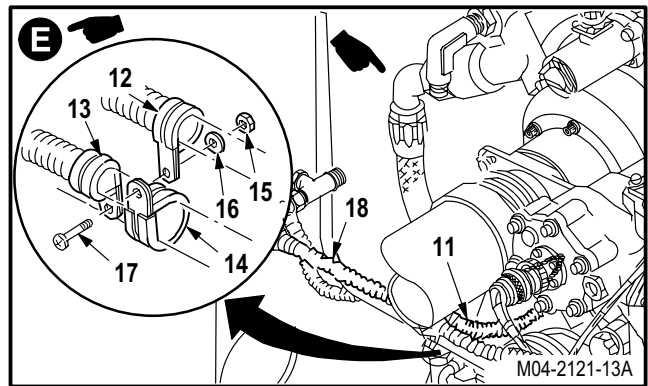

**f. Remove hose (11).**

- (1) Hold adapter (19). Remove nut (20).
- (2) Hold tee (4). Remove nut (21).
- (3) Remove hose (11).

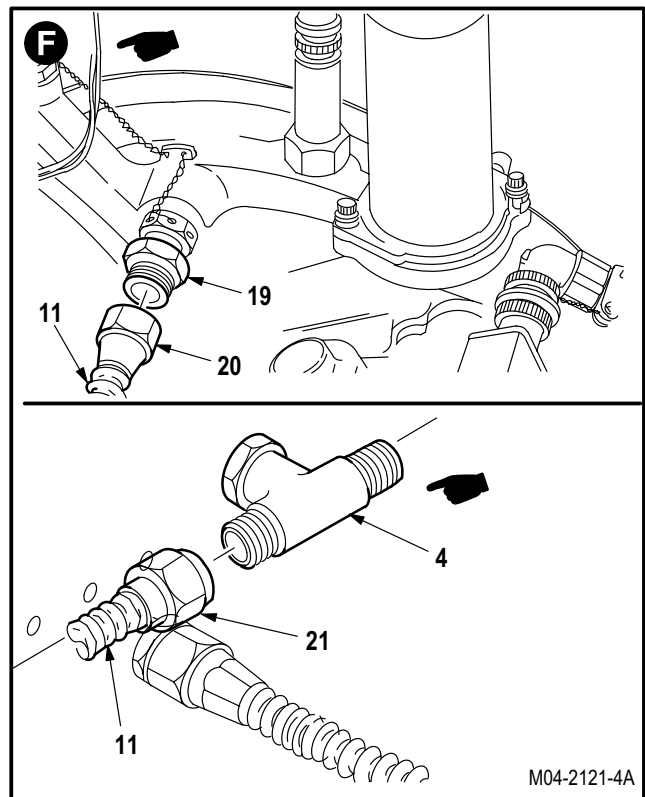

GO TO NEXT PAGE

**15.38. APU HYDRAULIC DRAIN HOSE REMOVAL/INSTALLATION - continued**

**g. Remove hose (18).**

- (1) Hold nipple (22). Remove nut (23).
- (2) Hold nipple (24). Remove nut (25).
- (3) Remove hose (18).

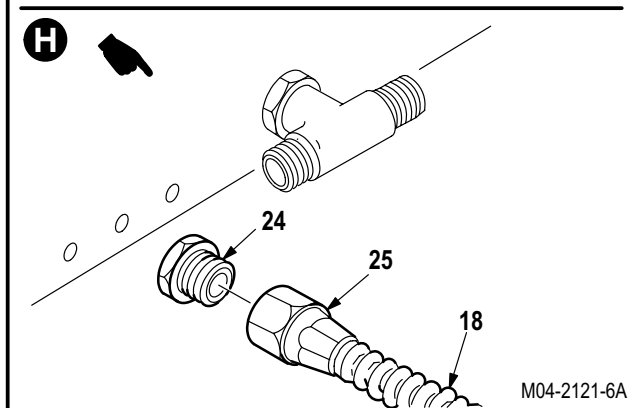
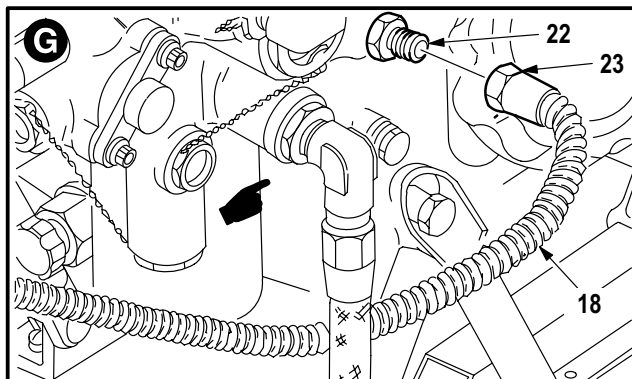

**h. Remove adapter (19) and vent fitting (26) from APU (27).**

- (1) Remove lockwire from fitting (26) and APU (27).
- (2) Hold fitting (26). Remove adapter (19) and packing (28).
- (3) Remove fitting (26) and packing (29).
- (4) Discard packings (28) and (29).

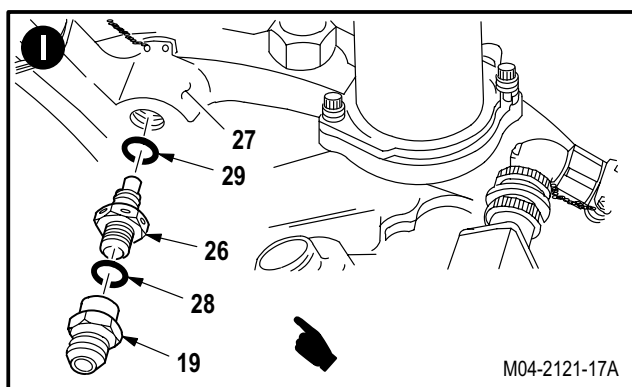

**15.38.4. Cleaning**

- a. **Clean removed and attaching parts** (para 1.47).

**15.38.5. Inspection**

- a. **Check APU drain hoses, mounting tees, nipples, vent fitting, and adapter for cracks and damaged threads** (para 15.1).
- b. **Check removed and attaching parts for corrosion** (para 1.49).

GO TO NEXT PAGE

**15.38. APU HYDRAULIC DRAIN HOSE REMOVAL/INSTALLATION - continued**

15.38.6. Installation



a. **Install fitting (26) on APU (27).** Torque fitting (26) to **20 INCH-POUNDS**.

- (1) Lubricate new packing (29). Use petrolatum (item 138, App F).
- (2) Install packing (29) and fitting (26) on APU (27).
- (3) Torque fitting (26) to **20 INCH-POUNDS**. Use torque wrench.

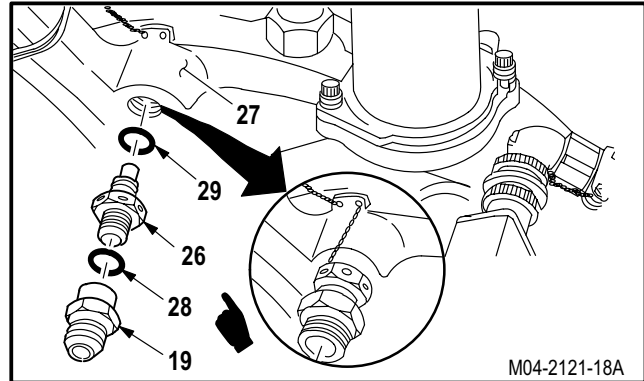

**NOTE**

Ensure vent fitting does not move when installing adapter.

b. **Install adapter (19) on fitting (26).** Torque adapter (19) to **20 INCH-POUNDS**.

- (1) Lubricate new packing (28). Use petrolatum (item 138, App F).
- (2) Hold fitting (26). Install packing (28) and adapter (19) on fitting (26). Torque adapter (19) to **20 INCH-POUNDS**. Use torque wrench.
- (3) Lockwire fitting (26) to APU (27). Use wire (item 226, App F).

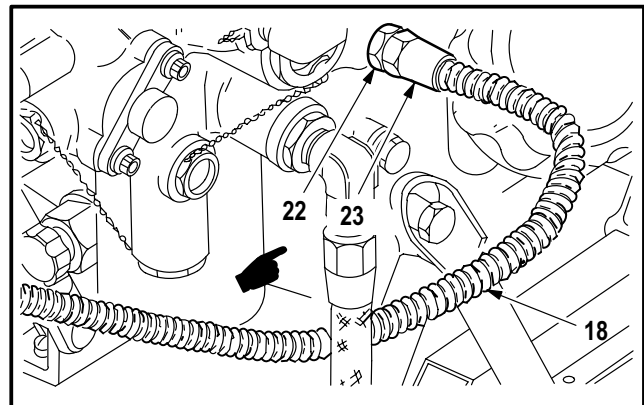

c. **Install fuel control drain hose (18) on nipples (22) and (24).**

- (1) Lubricate threads of nipple (22). Use petrolatum (item 138, App F).
- (2) Hold nipple (22). Install nut (23).
- (3) Hold nipple (24). Install nut (25).

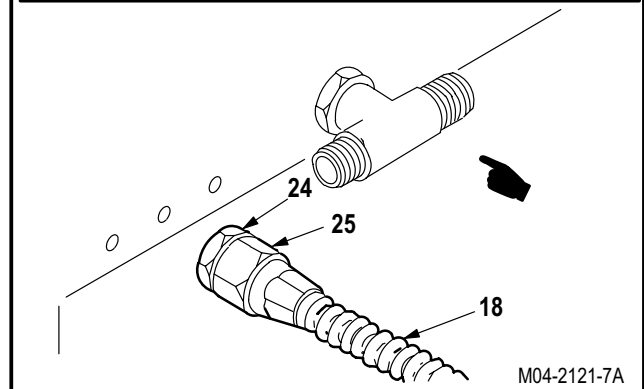

GO TO NEXT PAGE



**15.38. APU HYDRAULIC DRAIN HOSE REMOVAL/INSTALLATION - continued**

**d. Install gearbox vent hose (11) on adapter (19) and tee (4).**

- (1) Lubricate threads of adapter (19). Use petrolatum (item 138, App F).
- (2) Hold adapter (19). Install nut (20).
- (3) Hold tee (4). Install nut (21).

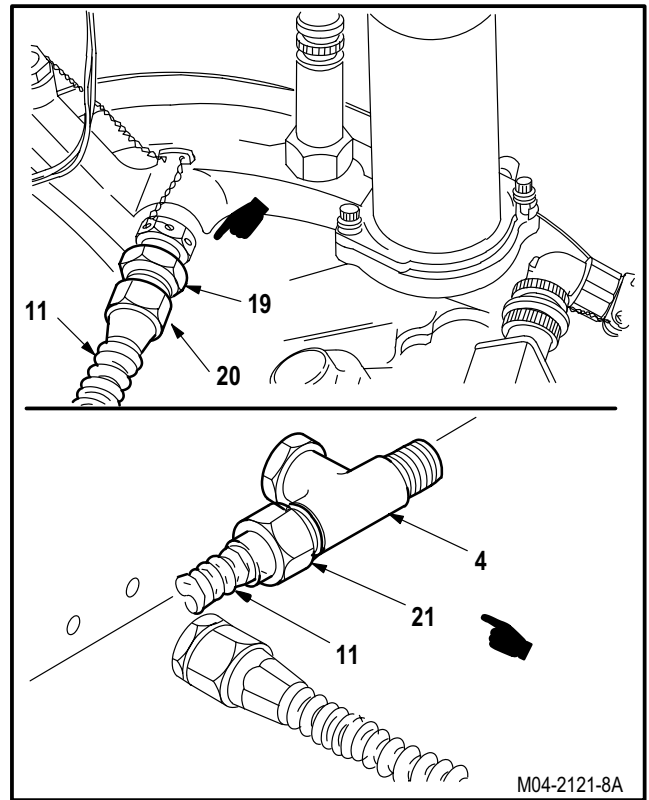

**e. Install hydraulic starter drain hose (1) on elbow (2) and tee (4).**

- (1) Lubricate threads of elbow (2). Use hydraulic fluid (item 92, App F).
- (2) Hold elbow (2). Install nut (3).
- (3) Hold tee (4). Install nut (5).

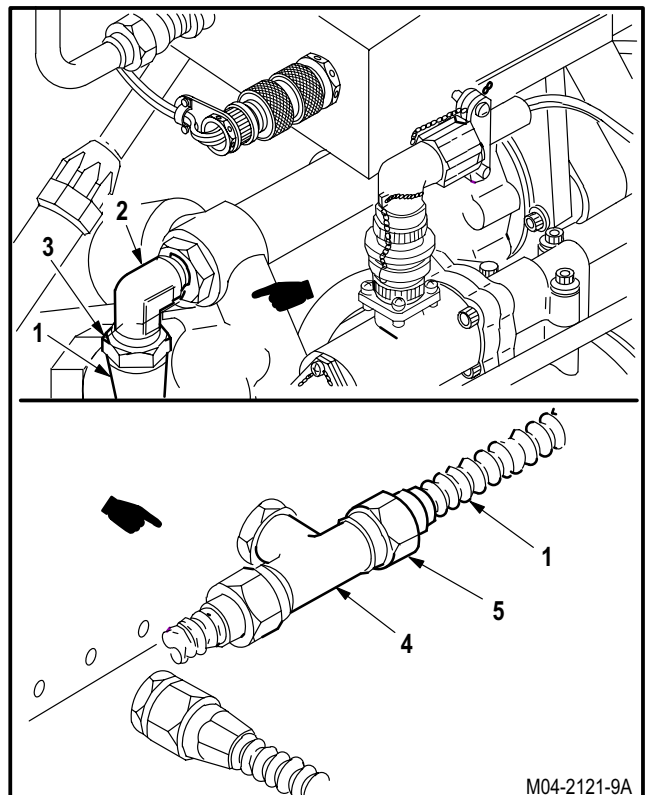

GO TO NEXT PAGE

**15.38. APU HYDRAULIC DRAIN HOSE REMOVAL/INSTALLATION - continued**

**f. Install clamps (12) and (13) on clamp (14).**

- (1) Install clamp (12) on hose (11).
- (2) Install clamp (13) on hose (18).
- (3) Position clamps (12) and (13) on each side of clamp (14).
- (4) Install screw (17) through clamps (12), (13), and (14).
- (5) Install washer (16) and nut (15) on screw (17).

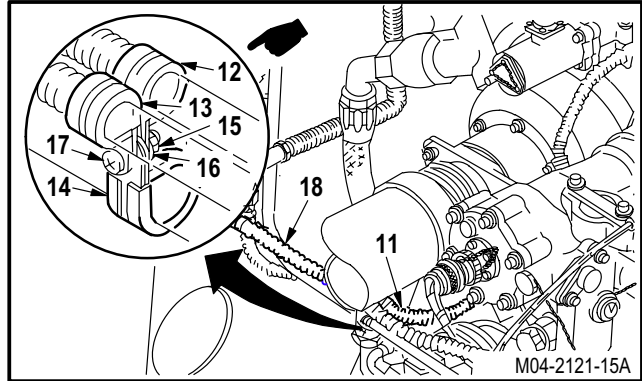

**g. Install clamp (6) on PTO clutch (7).**

- (1) Install clamp (6) on hose (11).
- (2) Position clamp (6) on clutch (7).
- (3) Install bolt (9) through washer (10), clamp (6), and clutch (7).
- (4) Install nut (8) on bolt (9).

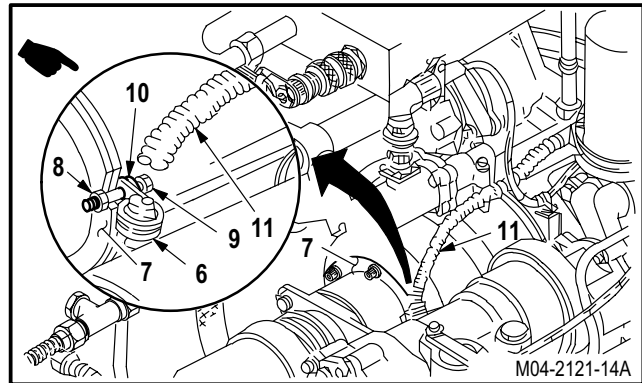

**h. Inspect (QA).**

**i. Install APU enclosure upper center cover (para 15.42).**

END OF TASK

**15.39. APU DRAIN TUBE REMOVAL/INSTALLATION**

15.39.1. Description

This task covers: Removal. Cleaning. Inspection. Installation.

15.39.2. Initial Setup

**Tools:**

- Aircraft maintenance tool kit (item 371, App H)
- Light duty laboratory apron (item 27, App H)
- Chemical protective gloves (item 154, App H)
- Adjustable air filtering respirator (item 262, App H)

**Personnel Required:**

- 68B Aircraft Powerplant Repairer  
One person to assist
- 67R3F Attack Helicopter Repairer/Technical Inspector

**Equipment Conditions:**

<u>Ref</u>	<u>Condition</u>
1.57	Helicopter safed
2.7	Engine work platform door RN1 opened
4.9	No. 2 engine radiation shroud removed
4.119	No. 2 engine primary nozzle and duct removed

**Materials/Parts:**

- Petrolatum (item 138, App F)

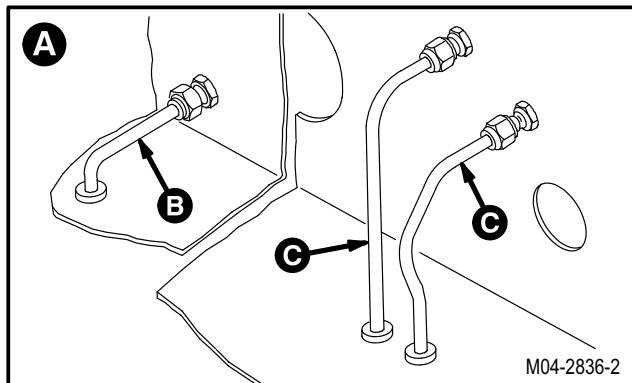
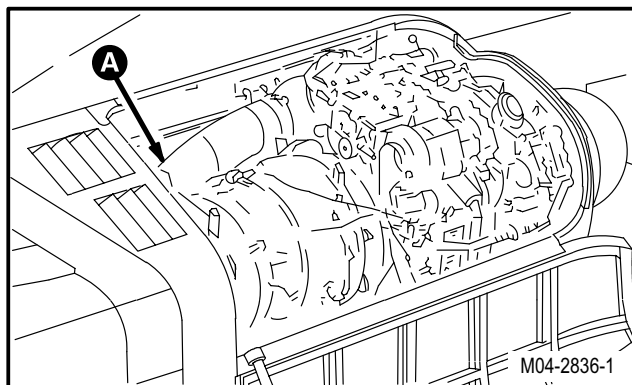

GO TO NEXT PAGE

**15.39. APU DRAIN TUBE REMOVAL/INSTALLATION - continued**

15.39.3. Removal

a. **Remove aft drain tube (1) from adapter (2).**

- (1) Hold flats (3) of adapter (2). Remove coupling nut (4).
- (2) Remove tube (1) from grommet (5).

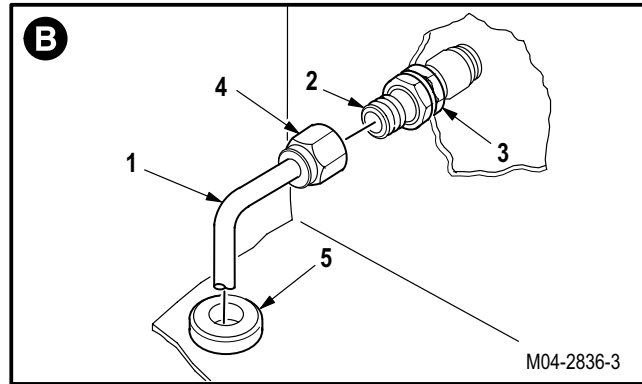

b. **Remove intermediate drain tube (6) from tee (7).**

- (1) Hold flats (8) of tee (7). Remove coupling nut (9).
- (2) Remove tube (6) from grommet (10).

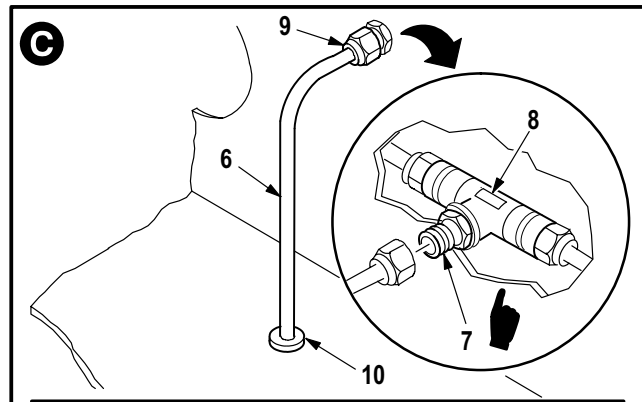

c. **Remove forward drain tube (11) from union (12).**

- (1) Hold flats (13) of union (12). Remove coupling nut (14).
- (2) Remove tube (11) from grommet (15).

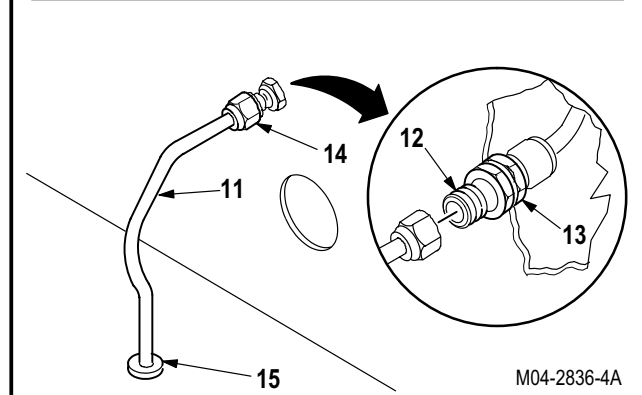

15.39.4. Cleaning

a. **Clean removed and attaching parts and surfaces (para 1.47).**

15.39.5. Inspection

- a. **Check fittings for bends, thread damage, and torn, worn, or missing grommets.**
- b. **Check removed and attaching parts and surfaces for corrosion (para 1.49).**

GO TO NEXT PAGE

**15.39. APU DRAIN TUBE REMOVAL/INSTALLATION - continued**15.39.6. Installation**a. Install tube (11) on union (12).**

- (1) Lubricate threads of union (12). Use petrolatum (item 138, App F).
- (2) Install tube (11) through grommet (15).
- (3) Hold flats (13) of union (12). Install coupling nut (14).

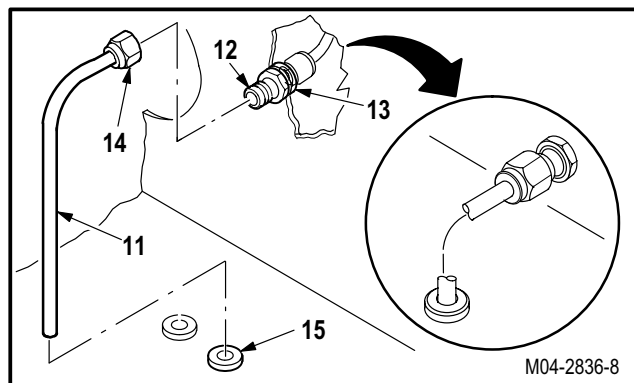
**b. Install tube (6) on tee (7).**

- (1) Lubricate threads of tee (7). Use petrolatum (item 138, App F).
- (2) Install tube (6) through grommet (10).
- (3) Hold flats (8) of tee (7). Install coupling nut (9).

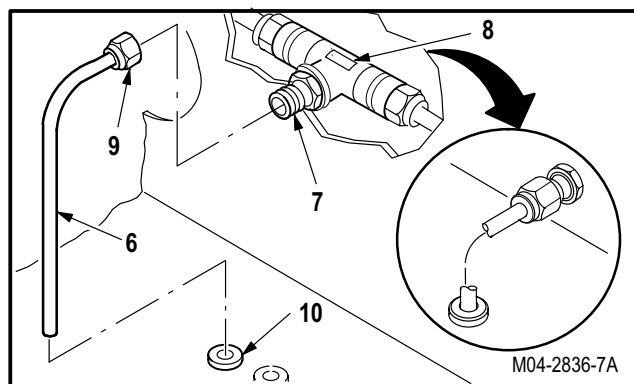
**c. Install tube (1) on adapter (2).**

- (1) Lubricate threads of adapter (2). Use petrolatum (item 138, App F).
- (2) Install tube (1) through grommet (5).
- (3) Hold flats (3) of adapter (2). Install coupling nut (4).

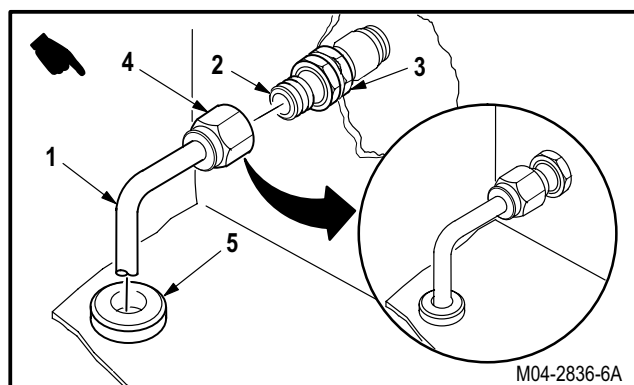
**d. Inspect (QA).**

**e. Install No. 2 engine primary nozzle and duct** (para 4.119).

**f. Install No. 2 engine radiation shroud** (para 4.55).

**g. Secure engine work platform door RN1** (para 2.7).

END OF TASK

## SECTION III. AUXILIARY POWER UNIT EXHAUST SYSTEM AND ENCLOSURE

---

### 15.40. APU EXHAUST NOZZLE AND DUCT REMOVAL/INSTALLATION

---

#### 15.40.1. Description

■ This task covers: Removal. Cleaning. Inspection. Repair. Installation.

---

#### 15.40.2. Initial Setup

##### **Tools:**

Aircraft maintenance tool kit (item 371, App H)  
1 3/4 & 2 3/4-inch rubber mallet (item 213, App H)  
0 - 75 inch-pound 1/4-inch drive dial indicator torque wrench (item 446, App H)

##### **References:**

TM 1-1520-238-T

##### **Materials/Parts:**

■ Tape (item 204, App F)

##### **Personnel Required:**

68B	Aircraft Powerplant Repairer
67R3F	Attack Helicopter Repairer/Technical Inspector

##### **Equipment Conditions:**

<u>Ref</u>	<u>Condition</u>
1.57	Helicopter safed
15.41	APU enclosure upper center cover removed

---

**WARNING**

**APU is easy to start. Disconnect battery. Remove all other electrical power before performing any maintenance in this area. Death or serious injury could result if APU starts. If injury occurs, seek medical aid.**

GO TO NEXT PAGE

**15.40. APU EXHAUST NOZZLE AND DUCT REMOVAL/INSTALLATION - continued**

15.40.3. Removal

- a. **Enter pilot station (para 1.56). Observe all safety precautions.**
- b. **On pilot center circuit breaker panel, open FUEL APU and APU HOLD circuit breakers.**

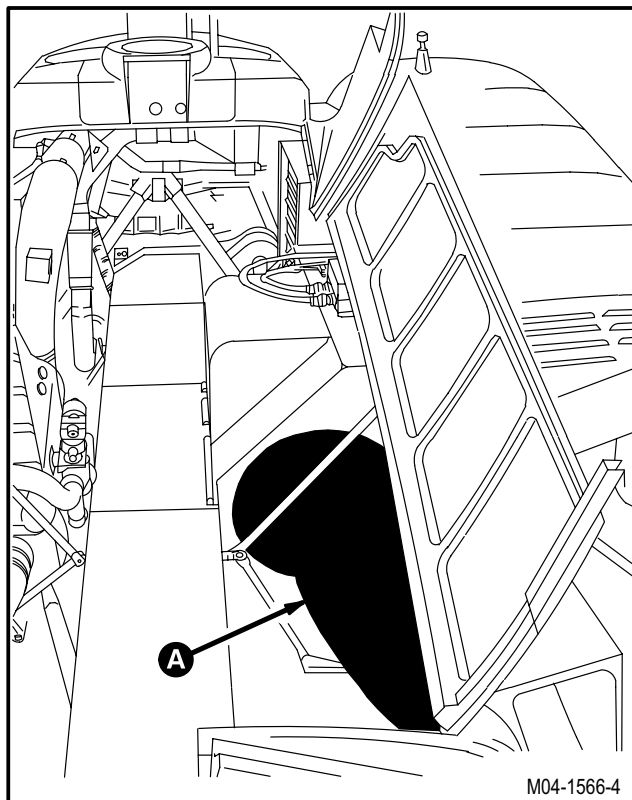

c. **Remove strut (1).**

- (1) Hold bolt (2). Remove nut (3) and washer (4).
- (2) Remove bolt (2) and washer (5).
- (3) Hold bolt (6). Loosen but do not remove nut (7).

d. **Remove exhaust nozzle (8) from plenum (9).**

- (1) Remove nut (10) from coupling (11).
- (2) Remove coupling (11) from plenum (9).
- (3) Place nozzle (8) inside duct (12).

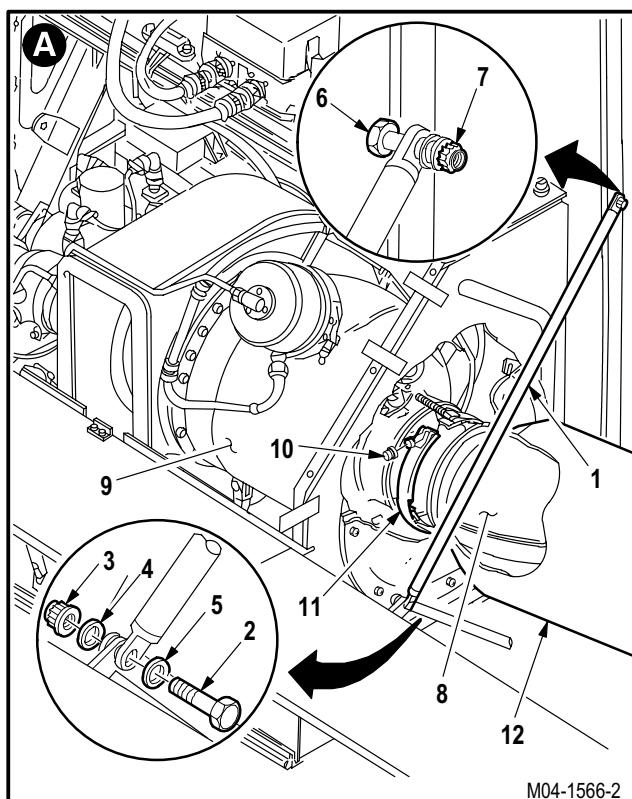

GO TO NEXT PAGE

**15.40. APU EXHAUST NOZZLE AND DUCT REMOVAL/INSTALLATION - continued**

**e. Remove exhaust duct (12) from helicopter.**

- (1) Remove eight screws (13) and washers (14).
- (2) Remove screw (15), two washers (16), and nut (17) from bracket (18).
- (3) Remove duct (12) and nozzle (8) from helicopter.
- (4) Remove nozzle (8) from duct (12).

**15.40.4. Cleaning**

- a. **Clean removed and attaching parts** (para 1.47).

**15.40.5. Inspection**

- a. **Check exhaust nozzle and duct for cracks, dents, and distortion** (para 15.1).
- b. **Check exhaust nozzle and duct for oxidation, erosion, and pitting** (para 15.1).
- c. **Check removed and attaching parts for corrosion** (para 1.49).

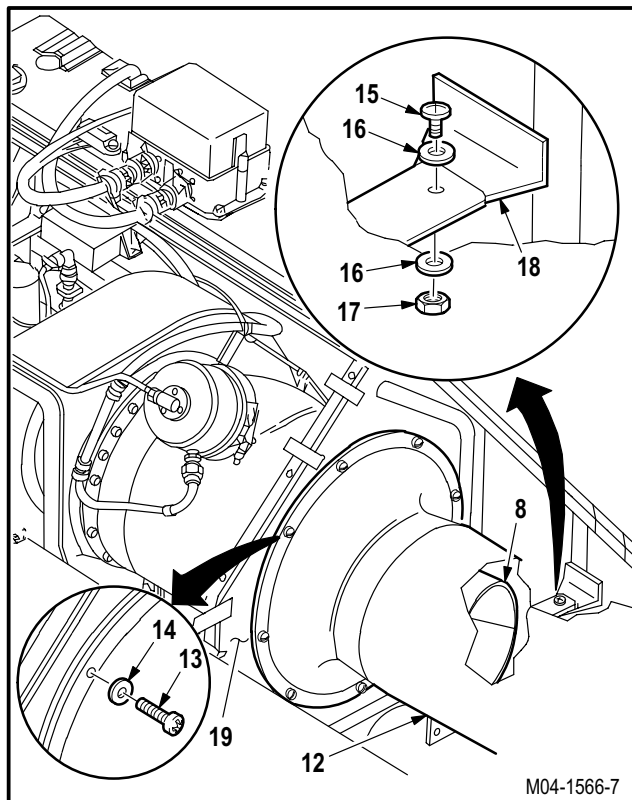

**15.40.6. Repair**

- a. **Repair cracks, tears, holes, punctures or roll-back on insulation blanket if damage is 4.0 inches or less.**
  - (1) Apply tape to overlap damaged or rolled back area at least **0.50 INCH**. Use tape (item 204, App F).

**15.40.7. Installation**

- a. **Install exhaust duct (12) and nozzle (8) in helicopter.**
  - (1) Position exhaust nozzle (8) in duct (12).
  - (2) Aline duct (12) with aft bulkhead (19).
  - (3) Insert screw (15) through washer (16), bracket (18), and washer (16).
  - (4) Install nut (17).
  - (5) Install eight screws (13) and washers (14).

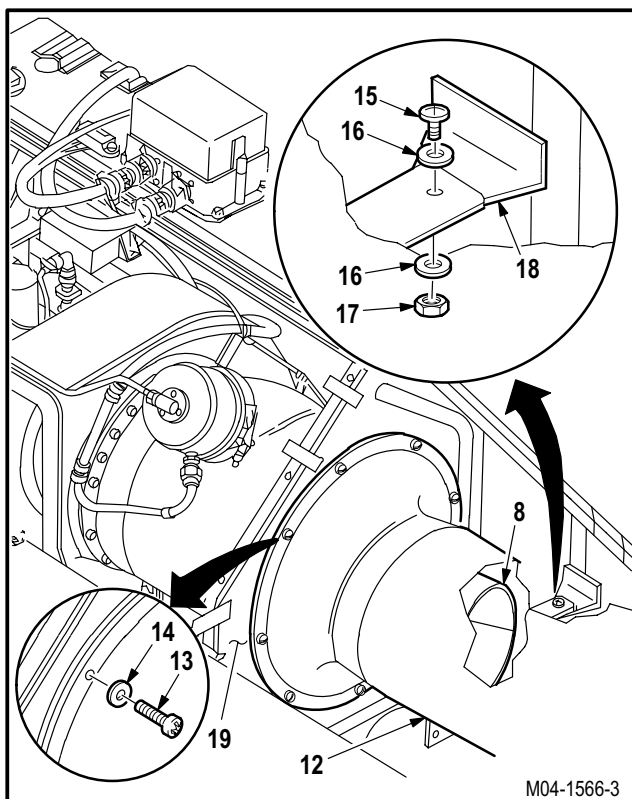

GO TO NEXT PAGE



## 15.40. APU EXHAUST NOZZLE AND DUCT REMOVAL/INSTALLATION - continued

**CAUTION**

Do not over torque coupling. Damage will occur to the coupling, nozzle, and plenum.

**b. Install exhaust nozzle (8) on plenum (9). Torque nut (10) to 30 INCH-POUNDS.**

- (1) Install coupling (11) around flange of nozzle (8) and plenum (9).
- (2) Install nut (10) on coupling (11).
- (3) Torque nut (10) to **20 INCH-POUNDS**. Use torque wrench.
- (4) Tap around outside of coupling (11). Use mallet.
- (5) Torque nut (10) to **30 INCH-POUNDS**. Use torque wrench.

**c. Install strut (1).**

**NOTE**

Ensure lower strut is forward of bracket and upper strut is aft of bracket.

- (1) Pull strut (1) down to align with lower strut (20) and bracket (21).
- (2) Install bolt (2) through washer (5), strut (1), bracket (21), lower strut (20), and washer (4).
- (3) Install nut (3) on bolt (2).
- (4) Tighten nut (7) on bolt (6).

**d. Inspect (QA).**

**e. Install APU enclosure upper center cover (para 15.42).**

**NOTE**

Torque check of exhaust coupling required after initial APU run.

**f. Perform auxiliary power unit maintenance operational check (TM 1-1520-238-T).**

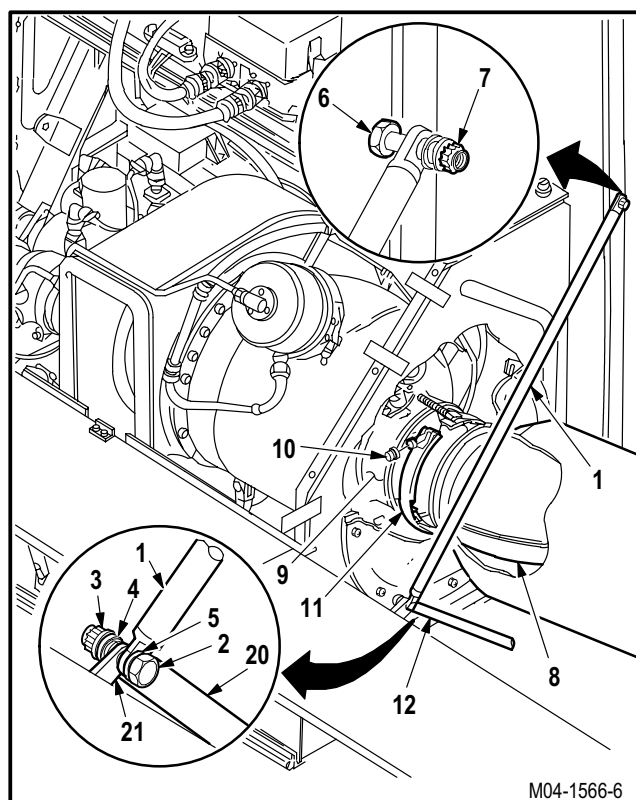

END OF TASK

**15.41. APU ENCLOSURE REMOVAL**

15.41.1. Description

This task covers: Removal. Cleaning. Inspection. Repair.

15.41.2. Initial Setup

**Tools:**

Aircraft mechanic's tool kit (item 376, App H)  
 Airframe repairman's tool kit (item 377, App H)  
 Electrical tool kit (item 378, App H)  
 Light duty laboratory apron (item 27, App H)  
 Chemical protective gloves (item 154, App H)  
 Adjustable air filtering respirator (item 262, App H)

**Personnel Required:**

67R Attack Helicopter Repairer  
 68G Aircraft Structural Repairer  
 68X Armament/Electrical System Repairer  
 67R3F Attack Helicopter Repairer/Technical Inspector

**References:**

TM 1-1500-204-23

**Materials/Parts:**

Grommet (Table D-19, App D)  
 Seal (Table D-167, App D)  
 Adhesive (item 3, App F)  
 Methyl ethyl ketone (item 124, App F)  
 Paper (item 134, App F)  
 Tape (item 205, App F)

**Equipment Conditions:**

<u>Ref</u>	<u>Condition</u>
1.57	Helicopter safed
2.2	Access doors T250L, T250R, T290L, T290R, and L325 opened
15.23	APU controller removed
■ 15.24	APU time totalizing meter removed

GO TO NEXT PAGE

## 15.41. APU ENCLOSURE REMOVAL - continued

**WARNING**

APU is easy to start. Disconnect battery. Remove all other electrical power before performing any maintenance in this area. Death or serious injury could result if APU starts. If injury occurs, seek medical aid.

## 15.41.3. Removal

- a. Enter pilot station (para 1.56). Observe all safety precautions.
- b. On pilot center circuit breaker panel, open FUEL APU and APU HOLD circuit breakers.

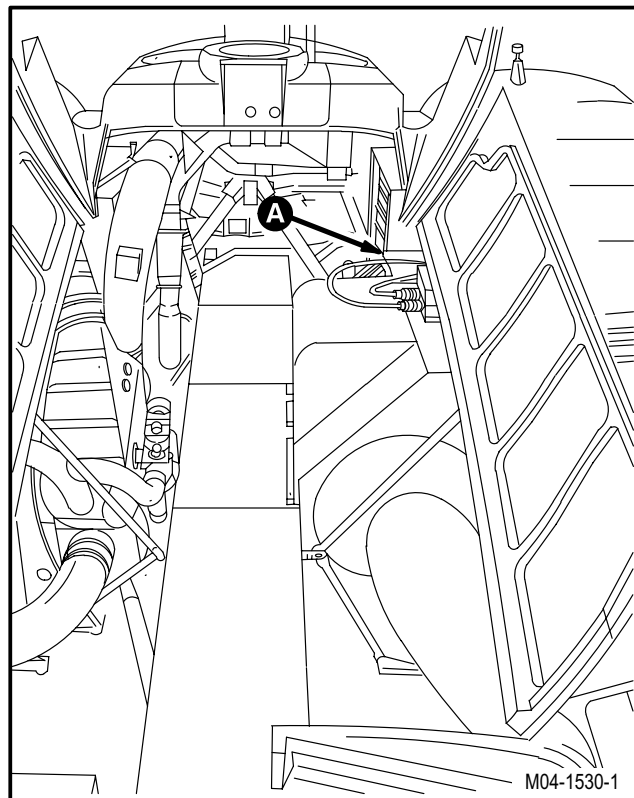

## c. Remove upper center cover (1).

- (1) Unlock six hook-and-pile fasteners (2).
- (2) Remove four screws (3) and washers (4).
- (3) Remove upper center cover (1).

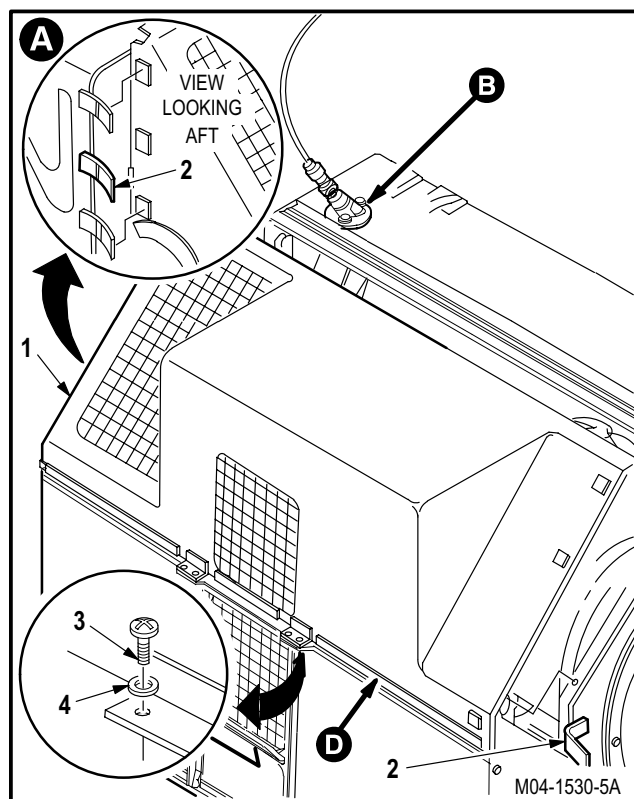

GO TO NEXT PAGE

15.41. APU ENCLOSURE REMOVAL - continued

d. Detach connector P78 (5) from receptacle (A10)J1 (6).

e. Remove flame detector (7) from cover (8).

- (1) Remove two screws (9) and washers (10).
- (2) Remove detector (7).

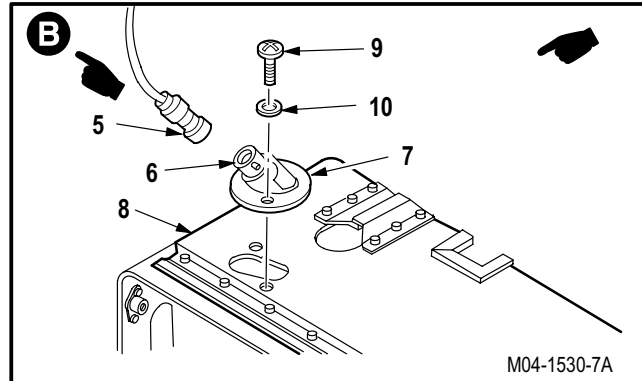

f. Remove cover (8).

- (1) Unlock four fasteners (11).
- (2) Disengage three spring clips (12) by pulling up on cover (8).
- (3) Remove cover (8).

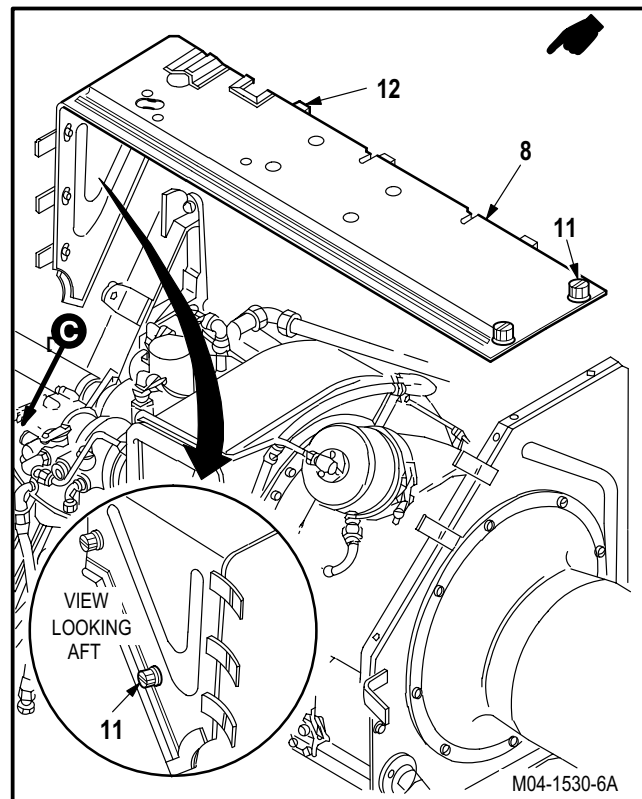

GO TO NEXT PAGE

**15.41. APU ENCLOSURE REMOVAL - continued**

**g. Remove fire extinguishing tube (13) from fitting (14).**

(1) Hold elbow (15). Remove nut (16).

**h. Remove fitting (14) from forward upper panel (17).**

(1) Hold three screws (18). Remove three nuts (19) and washers (20).

(2) Remove three screws (18) and fitting (14).

**i. Remove panel (17).**

(1) Unlock seven fasteners (21).

(2) Remove panel (17).

**j. Remove forward lower panel (22).**

(1) Remove two screws (23) and washers (24).

(2) Remove panel (22).

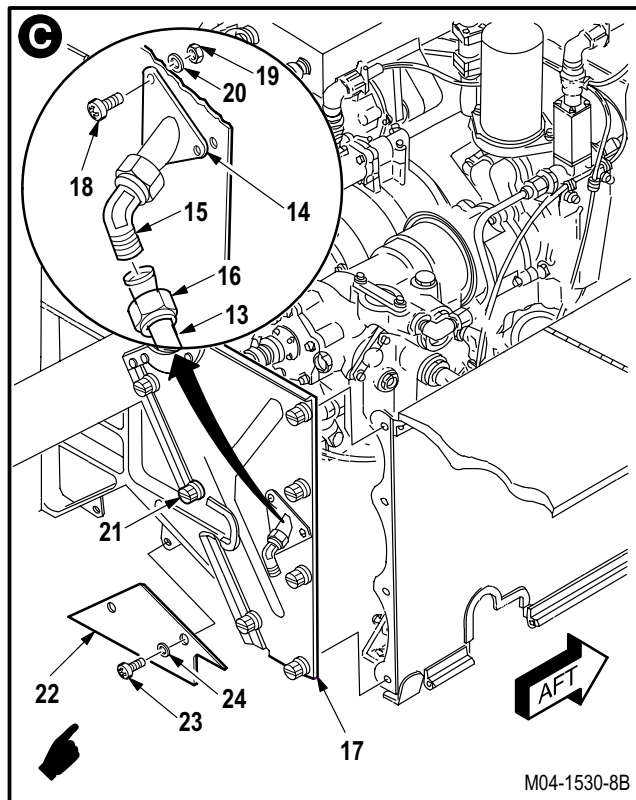

M04-1530-8B

**k. Remove forward catwalk panel (para 2.84).**

**l. Remove center forward catwalk panel (para 2.84).**

**m. Remove screw and washer from forward right corner of center aft catwalk panel (para 2.84).**

**n. Remove lower center cover (25).**

(1) Remove five screws (26) and washers (27).

(2) Unlock three fasteners (28).

(3) Remove cover (25).

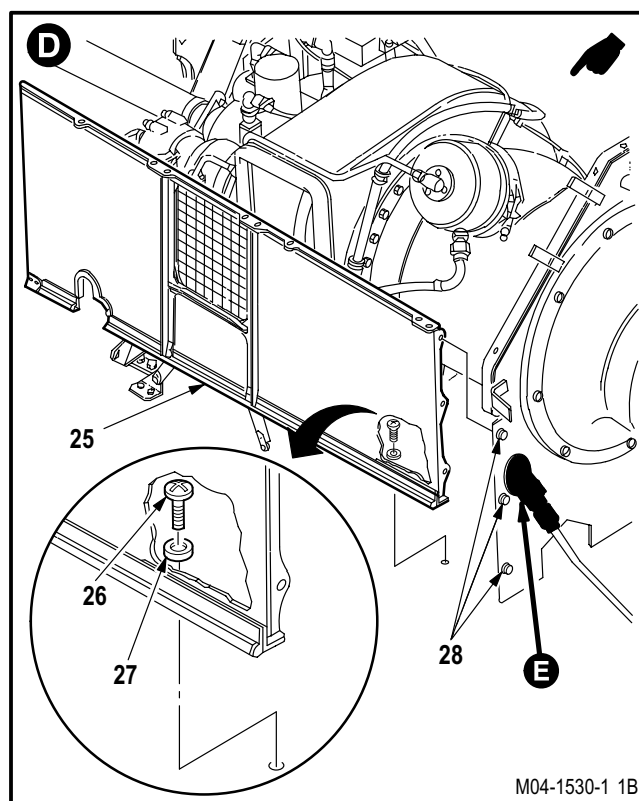

M04-1530-1 1B

GO TO NEXT PAGE

15.41. APU ENCLOSURE REMOVAL - continued

**NOTE**

Perform step o. if aft bulkhead is to be removed. Perform steps o. and p. if aft bulkhead is to be replaced.

**o. Detach connector P79 (29) from receptacle (A11)J1 (30).**

**p. Remove flame detector (31) from aft bulkhead (32).**

(1) Hold two screws (33). Remove two nuts (34) and washers (35).

(2) Remove two screws (33) and detector (31).

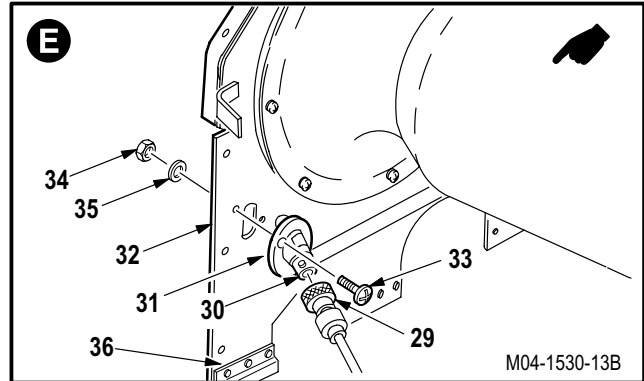

**q. Remove bulkhead (32).**

(1) Remove exhaust duct (para 15.40).

(2) Pull aft on bulkhead (32) to disengage three spring clips (36) and (37) at firewall (38) and deck (39).

(3) Remove bulkhead (32).

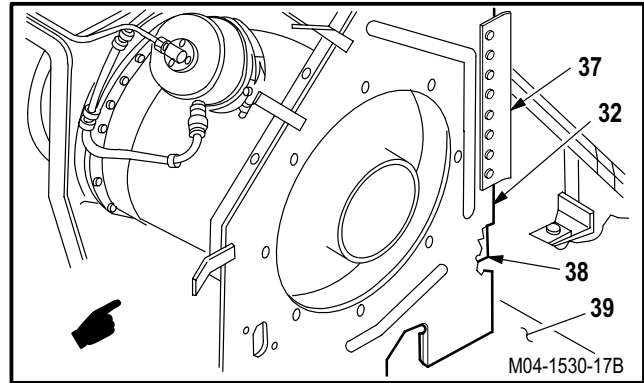

15.41.4. Cleaning

**a. Wipe panels, supports, and brackets with a clean rag.**

**b. Remove residual sealant (para 1.47).**

15.41.5. Inspection

**a. Check for delaminated or cracked bulkhead, panels, and covers (para 15.1).**

**b. Check for loose, missing or damaged hook-and-pile fasteners, stud fasteners, turnlock receptacles, nutplates, doublers, seals, and clips (para 15.1).**

**c. Check removed and attaching parts for corrosion (para 1.49).**

GO TO NEXT PAGE

## 15.41. APU ENCLOSURE REMOVAL - continued

### 15.41.6. Repair



#### a. Repair bulkhead (32) by replacing seal (40).

- (1) Remove seal (40) from aft bulkhead (32).
  - (a) Cut away and discard defective portion of seal (40).
- (2) Clean area where seal (40) was removed. Use methyl ethyl ketone (item 124, App F) and clean rag.
- (3) Install new seal (40) on APU aft bulkhead (32).
  - (a) Cut seal (40) to desired length.
  - (b) Place seal (40) on bulkhead (32) and cut holes as necessary.
  - (c) Apply adhesive to bulkhead (32). Use adhesive (item 3, App F).
  - (d) Place seal (40) on bulkhead (32). Apply pressure until adhesive holds seal (40) in place.
  - (e) Allow adhesive to cure **20 MINUTES** at ambient temperature.

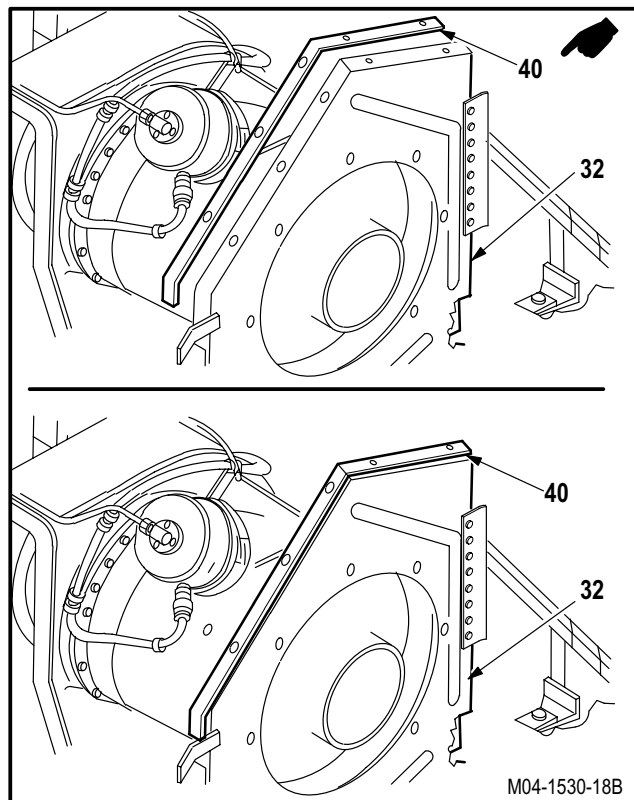

GO TO NEXT PAGE

15.41. APU ENCLOSURE REMOVAL - continued



b. Repair lower center cover (25) by replacing seals (41) and (42).

- (1) Remove 29 rivets (43) and washers (44) (TM 1-1500-204-23).
- (2) Remove retainers (45) and (46), seals (41) and (42), two clips (47) and clip (48) from two stiffeners (49) and cover (25).
- (3) Discard seals (41) and (42).
  - (a) Visually check cover and retainers for cracks or damage.

**CAUTION**

Ensure seals, clips, and retainers are positioned under existing stiffeners. Improper installation could cause stiffeners to crack.

- (4) Install two clips (47), clip (48), new seals (41) and (42), and retainers (45) and (46) under two stiffeners (49) on cover (25).
- (5) Install 29 washers (44) and rivets (43) (TM 1-1500-204-23).

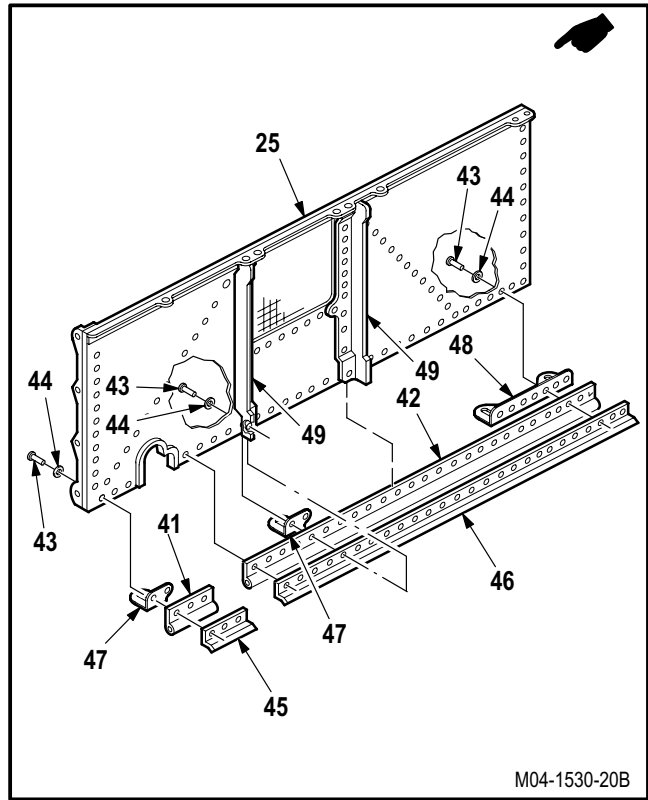

M04-1530-20B

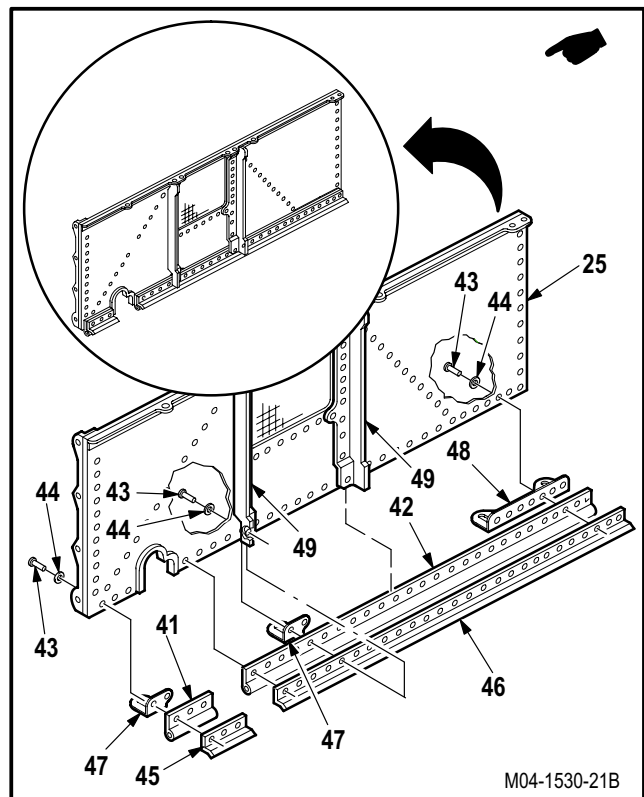

M04-1530-21B

GO TO NEXT PAGE



15.41. APU ENCLOSURE REMOVAL - continued

c. Repair upper forward panel (17) by replacing seal (50).

- (1) Remove five rivets (51) and washers (52) (TM 1-1500-204-23).
- (2) Remove retainer (53) and seal (50) from panel (17). Discard seal.
  - (a) Visually check retainer (53) and panel (17) for cracks and damage.
- (3) Install new seal (50) and retainer (53) on panel.
- (4) Install five washers (52) and rivets (51) (TM 1-1500-204-23).

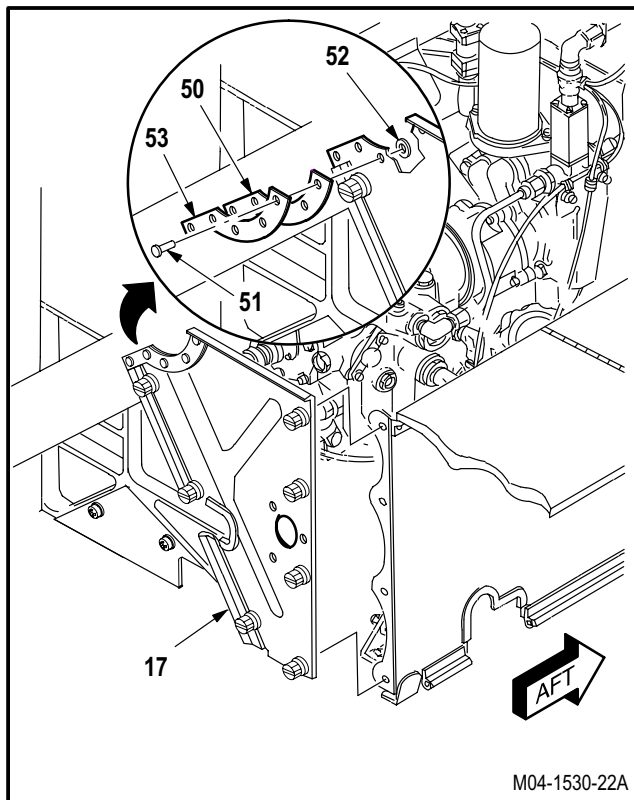

d. Repair upper forward panel (17) by replacing grommet (54).

- (1) Remove grommet (54) from panel (17) and discard.
  - (a) Visually check panel (17) for cracks and damage.
- (2) Prepare attaching area for adhesive bonding.
  - (a) Sand area down to parent kevlar material. Use paper (item 134, App F).
  - (b) Clean with methyl ethyl ketone (item 124, App F) and clean rag.
- (3) Install new grommet (54) on panel (17). Use adhesive (item 3, App F).
  - (a) Cut new grommet (54) to size.

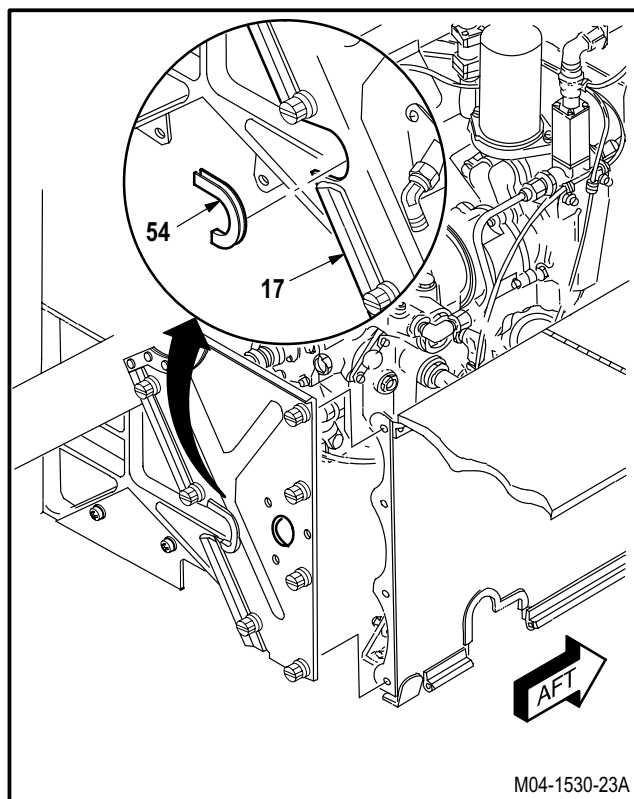

GO TO NEXT PAGE

---

**15.41. APU ENCLOSURE REMOVAL - continued**

---

- (b) Bond new grommet (54) to panel (17). Use adhesive (item 3, App F).
- (c) Tape grommet (54) in place. Use tape (item 205, App F).
- (d) Allow adhesive to cure per manufacturer's instructions.
- (e) Remove excess adhesive. Use paper (item 134, App F).

**e. Inspect (QA).**

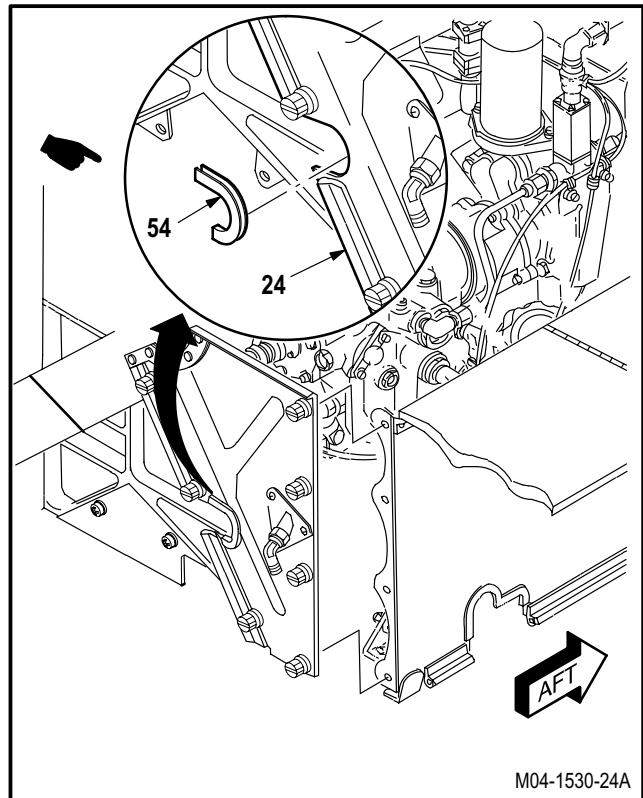

END OF TASK

## 15.42. APU ENCLOSURE INSTALLATION

### 15.42.1. Description

This task covers: Installation.

### 15.42.2. Initial Setup

#### Tools:

- Aircraft mechanic's tool kit (item 376, App H)
- Electrical tool kit (item 378, App H)
- Light duty laboratory apron (item 27, App H)
- Chemical protective gloves (item 154, App H)
- Adjustable air filtering respirator (item 262, App H)
- 150 - 750 inch-pound 3/8-inch drive click type torque wrench (item 442, App H)
- 0 - 75 inch-pound 1/4-inch drive dial indicator torque wrench (item 446, App H)

#### Materials/Parts:

- Sealing compound (item 176, App F)

#### Personnel Required:

- 67R Attack Helicopter Repairer
- 68X Armament/Electrical System Repairer
- 67R3F Attack Helicopter Repairer/Technical Inspector

#### References:

- TM 1-1520-238-T

#### Equipment Conditions:

<u>Ref</u>	<u>Condition</u>
1.57	Helicopter safed
2.2	Access doors T250L, T250R, T290L, T290R, and L325 opened

### 15.42.3. Installation

**CAUTION**

Tail rotor drive shaft and catwalk supports can be damaged while catwalk panels are removed. Use care when working in this area.

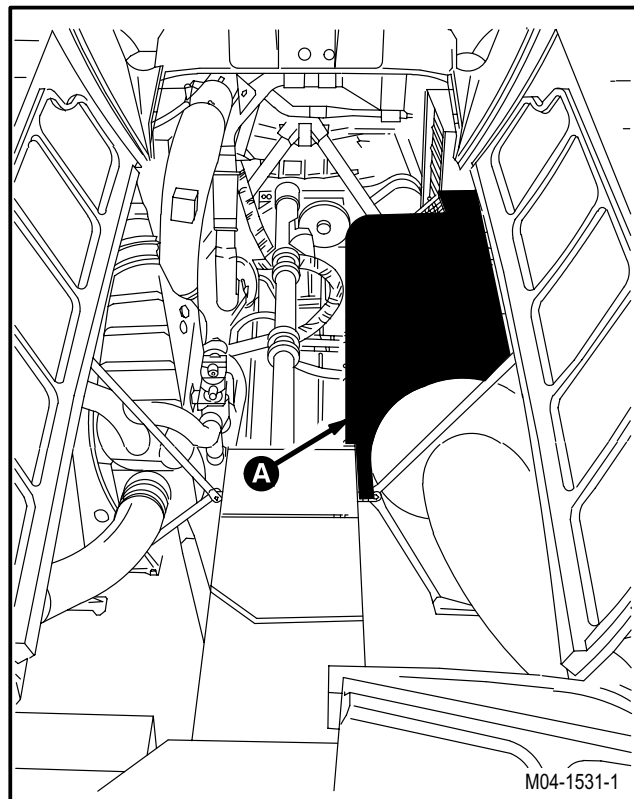

M04-1531-1

GO TO NEXT PAGE

15.42. APU ENCLOSURE INSTALLATION - continued

a. Install aft bulkhead (1).

- (1) Position bulkhead (1).
- (2) Push forward to engage spring clips at fire-wall (2) and deck (3).
- (3) Install exhaust duct (para 15.40).

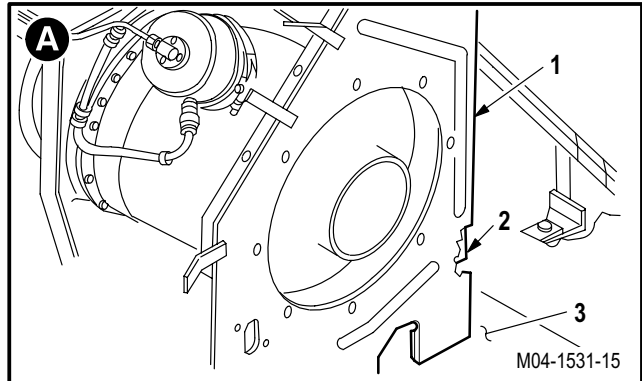

b. Install flame detector (4) on aft bulkhead (1), if previously removed.

**NOTE**

Ensure that flame detector lens is pointing up.

- (1) Position flame detector (4) on aft bulkhead (1).
- (2) Install two screws (5) through flame detector (4) and aft bulkhead (1).
- (3) Hold screws (5). Install two washers (6) and nuts (7).

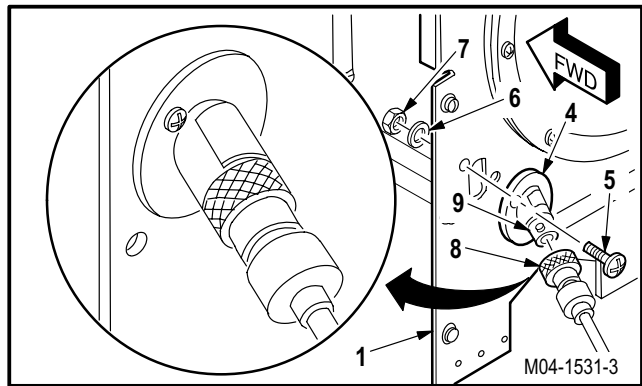

c. Attach connector P79 (8) to receptacle (A11)J1 (9).

d. Install lower center cover (10).

- (1) Aline cover (10) and lock three fasteners (11).
- (2) Install five screws (12) with washers (13).

e. Install screw and washer through forward right corner of center aft catwalk panel (para 2.84).

f. Install center forward catwalk panel (para 2.84).

g. Install forward catwalk panel (para 2.84).

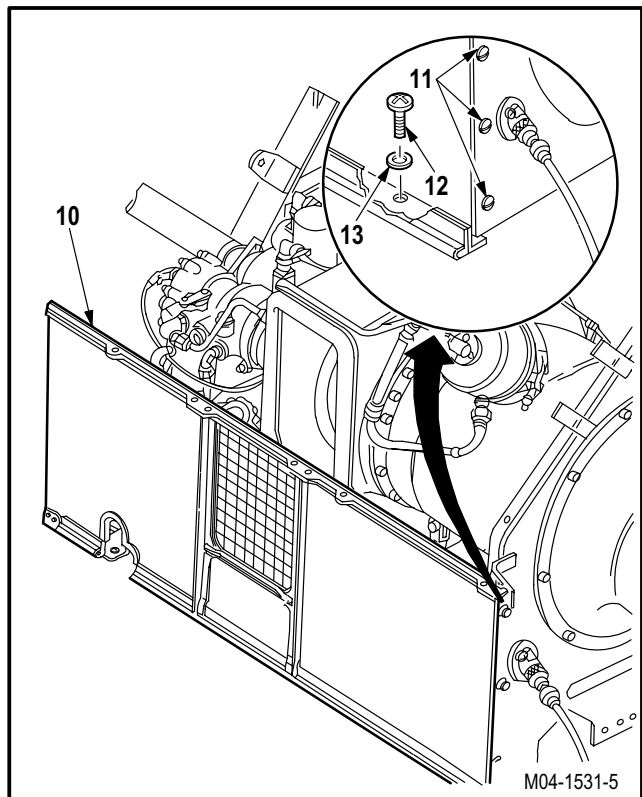

h. Seal three panel brackets at floor on center cover (10). Use sealing compound (item 176, App F).



GO TO NEXT PAGE

**15.42. APU ENCLOSURE INSTALLATION - continued**

**i. Aline and install forward lower panel (14).**

- (1) Install two screws (15) through washers (16) and panel (14) into structure.

**j. Install forward upper panel (17).**

- (1) Aline panel (17). Lock seven fasteners (18).

**k. Install fitting (19) on panel (17).**

- (1) Install three screws (20) through fitting (19) and panel (17).
- (2) Hold three screws (20). Install three washers (21) with nuts (22).

**l. Install fire extinguisher tube (23) on fitting (19). Torque tube nut to 360 INCH-POUNDS.**

- (1) Hold elbow (24) at flats.
- (2) Install tube nut (25).
- (3) Torque tube nut to **360 INCH-POUNDS**. Use torque wrench.

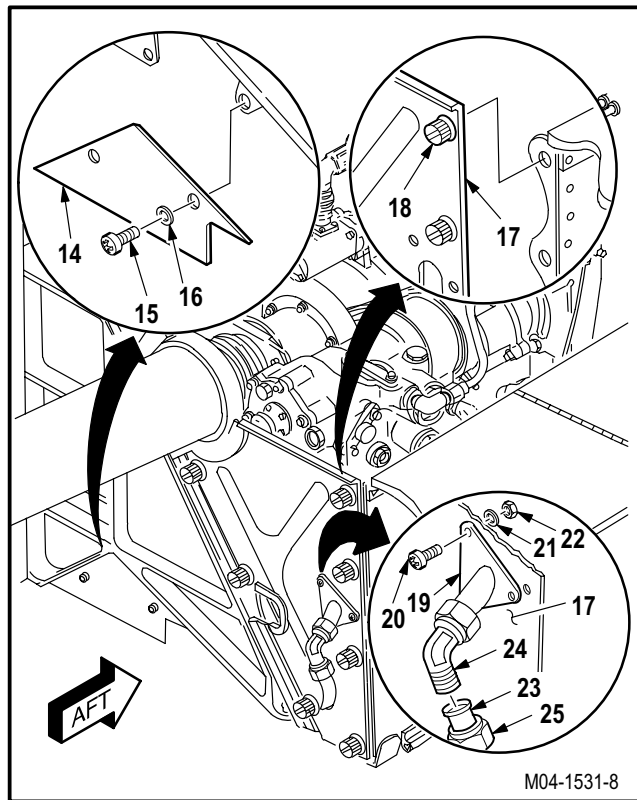

**m. Install top cover (26).**

- (1) Position cover (26) over three spring clips (27). Push down until clips (27) are engaged.
- (2) Lock four fasteners (28).

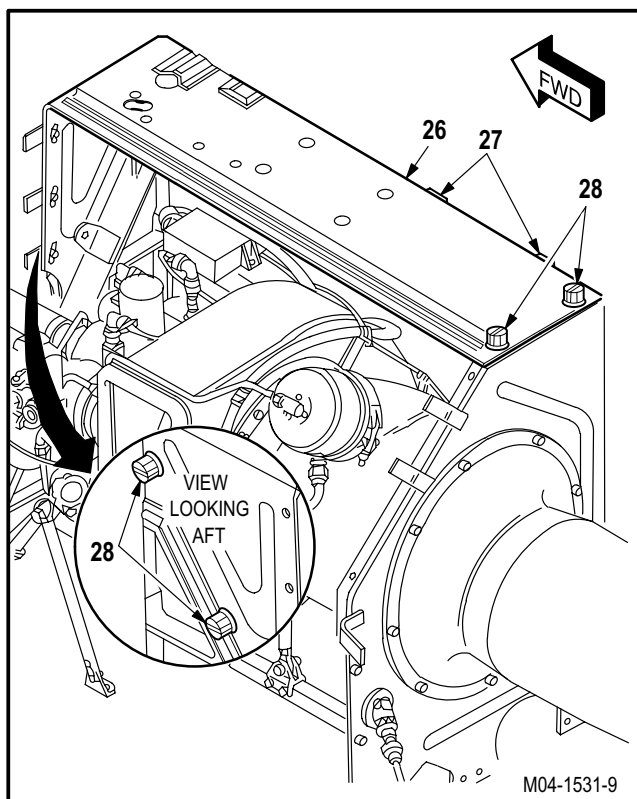

GO TO NEXT PAGE

15.42. APU ENCLOSURE INSTALLATION - continued

**NOTE**

Ensure flame detector lens is pointing aft.

n. **Install flame detector (29) on cover (26), if removed.**

- (1) Position detector (29) on cover (26).
- (2) Install two screws (30) through washers (31) and detector (29) into cover (26).

o. **Install APU controller** (para 15.23).

p. **Install APU time totalizing meter** (para 15.24).

q. **Attach connector P78 (32) to receptacle (A10)J1 (33).**

r. **Install upper center cover (34).**

- (1) Position cover (34) on APU enclosure. Lock six hook-and-pile fasteners (35).

s. **Install four screws (36) through washers (37) into cover (34).**

t. **Inspect (QA).**

u. **Secure access doors T250L, T250R, T290L, T290R, and L325** (para 2.2).

v. **Perform auxiliary power unit maintenance operational check** (TM 1-1520-238-T).

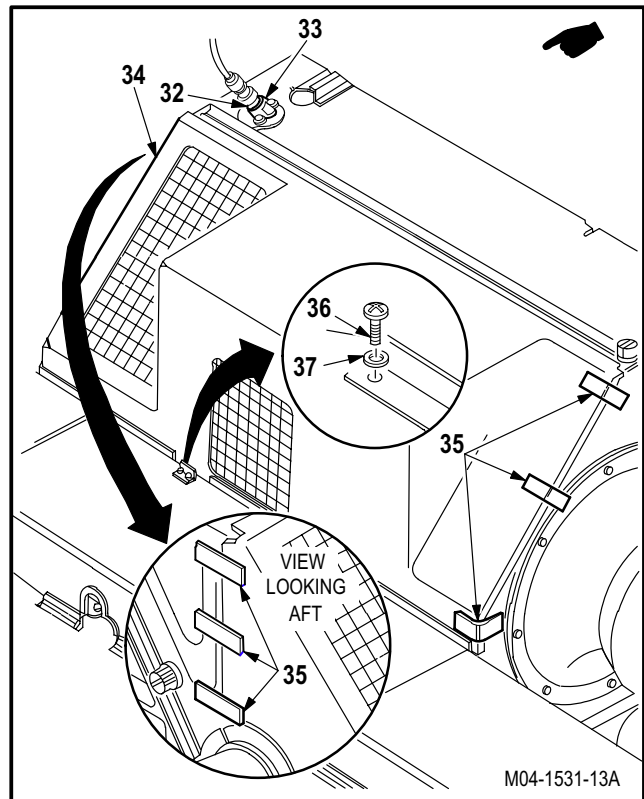
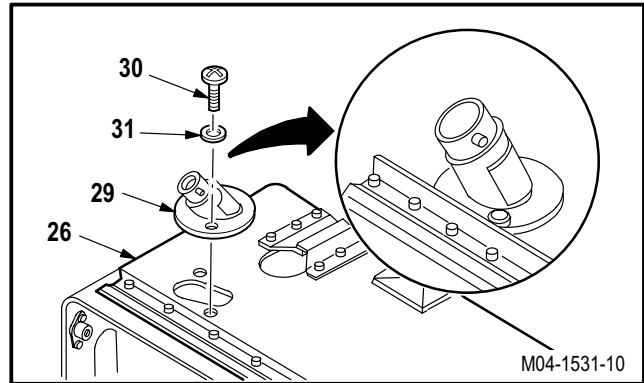

END OF TASK

**15.43. APU ENCLOSURE SUPPORT BRACKETS REMOVAL/INSTALLATION**

15.43.1. Description

This task covers: Removal. Cleaning. Inspection. Repair. Installation.

15.43.2. Initial Setup

**Tools:**

- Airframe repairman's tool kit (item 377, App H)
- Light duty laboratory apron (item 27, App H)
- 6-inch C clamp (item 61, App H)
- Chemical protective gloves (item 154, App H)
- Heat protective gloves (item 155, App H)
- Electric gun type heater (item 163, App H)
- Aircraft power unit (item 232, App H)
- Adjustable air filtering respirator (item 262, App H)

**Materials/Parts:**

- Adhesive (item 3, App F)
- Depressor (item 70, App F)
- Methyl ethyl ketone (item 124, App F)
- Primer (item 142, App F)

**Personnel Required:**

- 68G Aircraft Structural Repairer
- 67R3F Attack Helicopter Repairer/Technical Inspector

**References:**

TM 1-1500-204-23

**Equipment Conditions:**

<u>Ref</u>	<u>Condition</u>
1.57	Helicopter safed
15.41	APU enclosure removed

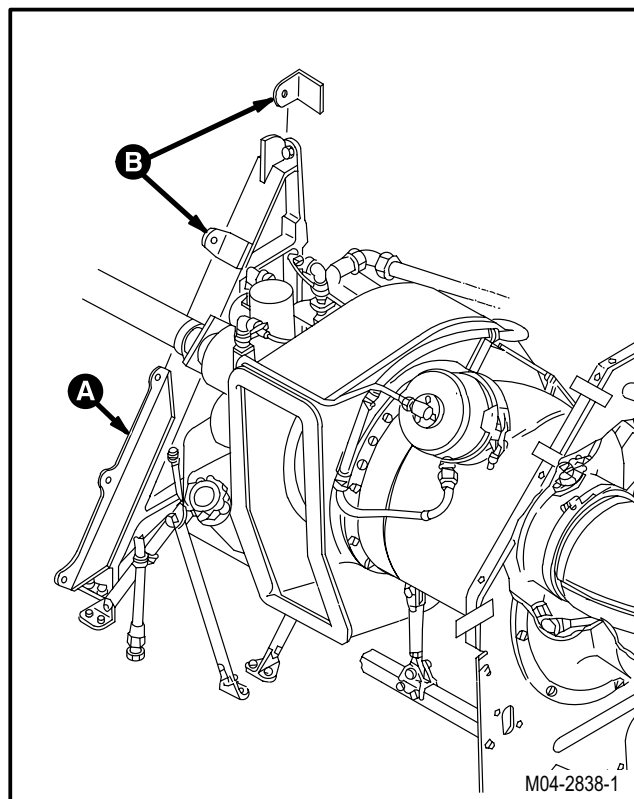

GO TO NEXT PAGE

15.43. APU ENCLOSURE SUPPORT BRACKETS REMOVAL/INSTALLATION - continued

15.43.3. Removal

**WARNING**

**Do not place heater near flammable material or allow heater to contact skin: severe burns can result. Wear protective equipment. If injury occurs, seek medical aid.**

a. Remove support bracket (1) from support (2).

- (1) Apply heat to bracket (1) and support assembly (2) for **1 HOUR**. Do not exceed 300 °F (148 °C). Use heater.
- (2) Remove bracket (1) by pulling to break adhesive bond.

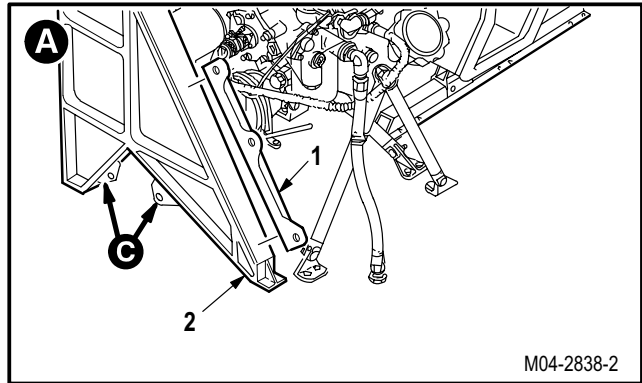

b. Remove two support brackets (3) from support (2).

- (1) Apply heat to brackets (3) and support assembly (2) for **1 HOUR**. Do not exceed 300 °F (148 °C). Use heater.
- (2) Remove two brackets (3) by pulling to break adhesive bond.

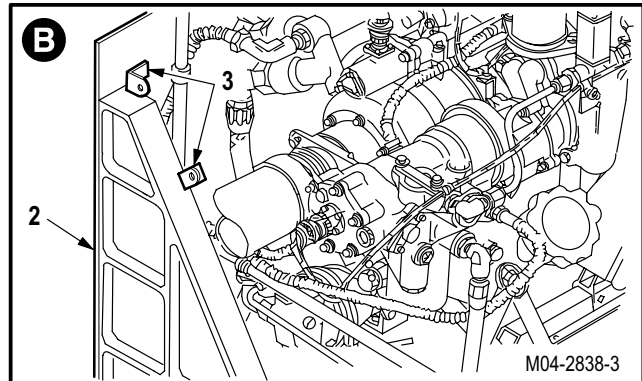

c. Remove APU if necessary (para 15.2).

d. Remove two lower support brackets (4) from support (2).

- (1) Apply heat to brackets (4) and support (2) for **1 HOUR**. Do not exceed 300 °F (148 °C). Use heater.
- (2) Remove brackets (4) by pulling to break adhesive bond.

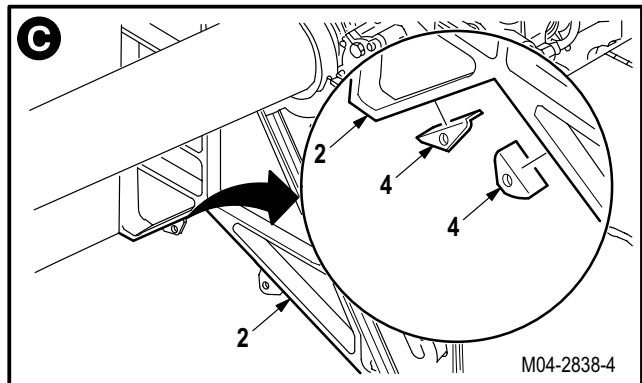

GO TO NEXT PAGE



---

**15.43. APU ENCLOSURE SUPPORT BRACKETS REMOVAL/INSTALLATION - continued**

---

15.43.4. Cleaning

- a. **Clean removed and attaching parts** (para 1.47).

15.43.5. Inspection

- a. **Check support assembly for cracks** (None allowed).
- b. **Check removed and attaching parts for corrosion** (para 1.49).

15.43.6. Repair

- a. **Repair bracket (1) by replacing turnlock receptacle (5)** (TM 1-1500-204-23).
- b. **Repair bracket (3) by replacing nutplate (6)** (TM 1-1500-204-23).
- c. **Repair bracket (4) by replacing turnlock receptacle (7)** (TM 1-1500-204-23).

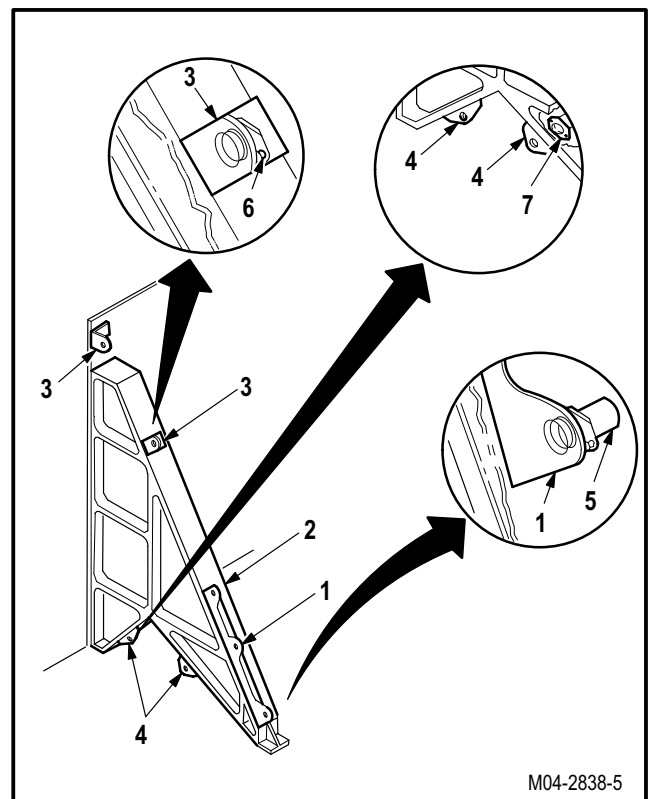

GO TO NEXT PAGE

15.43. APU ENCLOSURE SUPPORT BRACKETS REMOVAL/INSTALLATION - continued

15.43.7. Installation



**WARNING**

**Do not place heater near flammable material or allow heater to contact skin: severe burns can result. Wear protective equipment. If injury occurs, seek medical aid.**

a. Prepare support brackets (1), (3), and (4) and support (2) for bonding.

- (1) Apply a uniform coat of primer to mating surfaces of parts to be bonded. Use primer (item 142, App F).
- (2) Let primer air dry **30 MINUTES** minimum at room temperature.
- (3) Cure primed surfaces **30 to 35 MINUTES** at 300 to 310 °F (148 to 171 °C). Use heater.

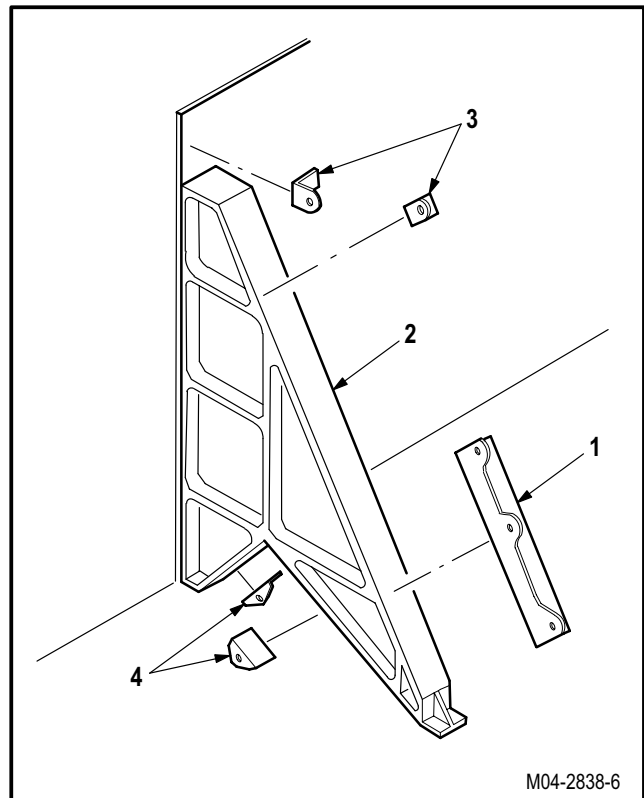

GO TO NEXT PAGE

---

**15.43. APU ENCLOSURE SUPPORT BRACKETS REMOVAL/INSTALLATION - continued**

---

**b. Install bracket (1) on support (2).**

- (1) Lightly wipe mating surfaces of bracket (1) and support assembly (2). Use methyl ethyl ketone (item 124, App F) and clean rag.
- (2) Position enclosure panel (8). Install three fasteners (9) in bracket (1).
- (3) Mark position of bracket (1) on support (2). Do not mark on mating surfaces.
- (4) Remove fasteners (9) from bracket (1). Remove panel (8).
- (5) Spread a thin, uniform layer of adhesive on mating surfaces. Use adhesive (item 3, App F) and depressor (item 70, App F).
- (6) Aline bracket (1) with marks on support (2). Press together. Clamp in place. Use C clamp.
- (7) Cure adhesive **1 HOUR** minimum at 190 to 210 °F (87 to 98 °C). Use heater.
- (8) Remove C clamp.

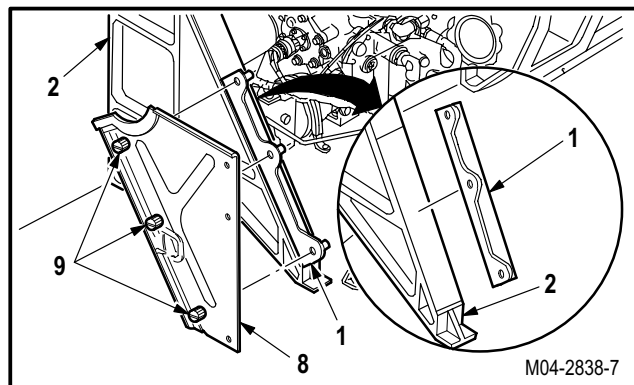

GO TO NEXT PAGE

15.43. APU ENCLOSURE SUPPORT BRACKETS REMOVAL/INSTALLATION - continued

c. Install support brackets (3) on support assembly (2).

- (1) Lightly wipe mating surfaces of bracket (3) and support assembly (2). Use methyl ethyl ketone (item 124, App F) and clean rag.
- (2) Position enclosure panel (10). Install two fasteners (11) in two brackets (3).
- (3) Mark position of bracket (3) on support (2). Do not use mating surfaces.
- (4) Remove fasteners (11) from brackets (3). Remove panel (10).
- (5) Spread a thin, uniform layer of adhesive on mating surfaces. Use adhesive (item 3, App F) and depressor (item 70, App F).
- (6) Aline bracket (3) with position marks on support (2). Press together and clamp in place. Use C clamp.
- (7) Cure adhesive **1 HOUR** minimum at 190 to 210 °F (87 to 98 °C). Use heater. Wear protective gloves.
- (8) Remove C clamp.

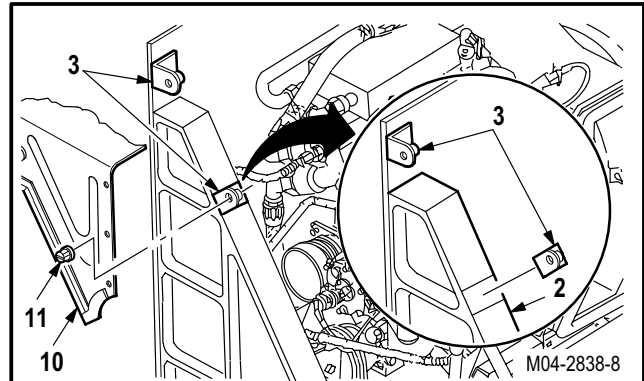

GO TO NEXT PAGE

---

**15.43. APU ENCLOSURE SUPPORT BRACKETS REMOVAL/INSTALLATION - continued**

---

**d. Install lower brackets (4) on support (2).**

- (1) Lightly wipe mating surfaces of bracket (4) and support (2). Use methyl ethyl ketone (item 124, App F) and clean rag.
- (2) Position enclosure panel (12). Install three fasteners (13) in bracket (4).
- (3) Mark position of bracket (4) on support (2). Do not use mating surfaces.
- (4) Remove fasteners (13) from brackets (4). Remove panel (12).
- (5) Spread a thin uniform layer of adhesive on mating surfaces. Use adhesive (item 3, App F) and depressor (item 70, App F).
- (6) Aline bracket (4) to position marks on support assembly (2). Press together and clamp in place. Use C clamp.
- (7) Cure adhesive **1 HOUR** minimum at 190 to 210 °F (87 to 98 °C). Use heater.
- (8) Remove C clamp.

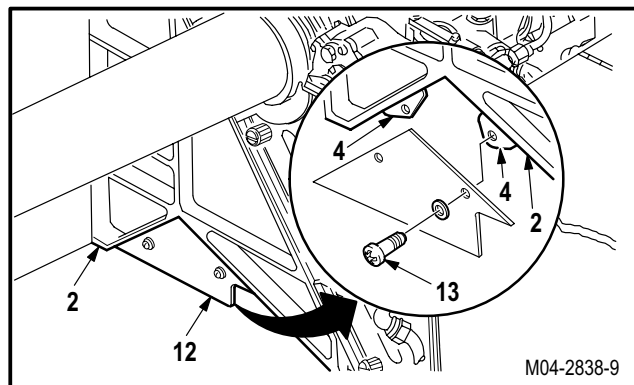
**e. Inspect (QA).**

f. **Install APU** (para 15.3).

g. **Install APU enclosure** (para 15.42).

END OF TASK



## CHAPTER 16 MISSION EQUIPMENT

### CHAPTER OVERVIEW

Chapter 16 contains the maintenance instructions for the mission equipment system. Mission equipment system description, operation, and troubleshooting information is contained in TM 1-1520-238-T.

### CHAPTER INDEX

<u>Para Title</u>	<u>Para No.</u>
<b>SECTION I. EXTERNAL STORES/PYLONS MAINTENANCE</b>	
Pylon Inspection .....	16.1
Pylon Removal/Installation .....	16.2
Pylon Rack Ejector Impulse Cartridge Removal/Installation .....	16.3
Pylon Rack Removal/Installation .....	16.4
Pylon Rack Disassembly/Assembly (AVIM) .....	16.5
Pylon Rack Ejector Removal/Installation .....	16.6
Pylon Rack Ejector Disassembly/Assembly .....	16.7
Pylon Rack Ejector Test Set Installation/Removal .....	16.8
Pylon Actuator and Top Plate Removal/Installation .....	16.9
Pylon Actuator Hose and Nipple Removal/Installation .....	16.10
Pylon Actuator Filter Hose and Adapter Removal/Installation .....	16.11
Pylon Actuator Cylinder Removal/Installation .....	16.12
Pylon Actuator Rod End Removal/Installation .....	16.13
Pylon Aerial Bracket Removal/Installation .....	16.14
Pylon Controller and Controller Bracket Removal/Installation .....	16.15

CHAPTER INDEX - continued

<u>Para Title</u>	<u>Para No.</u>
Pylon Multiplex Remote Terminal Unit (MRTU) Bracket Removal/Installation .....	16.16
Pylon Stow Bracket Removal/Installation .....	16.17
Pylon Wire Harness Replacement .....	16.18
Pylon Circuit Card and Jettison Wire Harness Removal/Installation .....	16.19
Pylon Frame Straight Pin Replacement .....	16.20
Pylon Sway Brace Replacement (AVIM) .....	16.21
Pylon Frame Removal/Installation .....	16.22
Pylon Telescoping Strut and Support Bracket Removal/Installation .....	16.23
Pylon Top Connector Plate Removal/Installation .....	16.24
Pylon Rack Bushing Replacement .....	16.25
Pylon Fairing Aft Bumper Replacement .....	16.26
Ground Maintenance Pylon Switch Removal/Installation .....	16.27
Ground Maintenance Pylon Switch Bracket Removal/Installation .....	16.28

**SECTION II. COUNTERMEASURE SYSTEM MAINTENANCE**

Chaff Dispenser Support Removal/Installation .....	16.29
Chaff Safety Switch Replacement .....	16.30
Radar Jammer Blower Assembly Removal/Installation .....	16.30A
Radar Jammer Blower Assembly Disassembly/Assembly .....	16.30B

**SECTION III. WINTERIZATION AND BATTERY COLD START SYSTEM MAINTENANCE**

Winterization Accumulator Removal/Installation .....	16.31
Battery Heater Blanket Removal/Installation .....	16.32
APU Cold Start - Battery .....	16.33



CHAPTER INDEX - continued

<u>Para Title</u>	<u>Para No.</u>	
<b>SECTION IV. DESERT OPERATION PROVISIONS MAINTENANCE</b>		
Desert Operation Provisions Description and Operation .....	16.35	
Aft Avionics Bay and Survival Bay Filter Replacement .....	16.35	■
APU Air Filter Replacement .....	16.36	

## SECTION I. EXTERNAL STORES/PYLONS MAINTENANCE

### 16.1. PYLON INSPECTION

#### 16.1.1. Description

This task covers: Inspection.

#### 16.1.2. Initial Setup

**Tools:**

Electrical tool kit (item 378, App H)  
 Light duty laboratory apron (item 27, App H)  
 Chemical protective gloves (item 154, App H)  
 5X & 12X monocular magnifier (item 206, App H)  
 Adjustable air filtering respirator (item 262, App H)  
 0 - 100 pound spring resiliency tester (item 352, App H)

**References:**

TM 1-1500-204-23  
 ■ TM 1-1520-264-23  
 TM 43-0001-39  
 TM 55-1500-323-24

**Personnel Required:**

68X Armament/Electrical System Repairer  
 68X3F Armament/Electrical System Repairer/  
 Technical Inspector

**Equipment Conditions:**

<u>Ref</u>	<u>Condition</u>
1.57	Helicopter safed

#### 16.1.3. Inspection

**a. Check pylon hollow pin for damage.**

- (1) Measure outside diameter of hollow pin approximately 5/8 INCH from each end. The diameter shall be no less than **1.434 INCHES** or out of round by no more than **0.001 INCH**. If out of tolerance replace hollow pin. Use caliper set.
- (2) Check bushing interface surface area for scoring or metal transfer. None allowed. Use magnifier.

**b. Check pylon frame assembly for cracks on both inboard and outboard sides.** Use magnifier around pivot pin area and up arm of frame. No cracks allowed. If cracks are suspected, perform nondestructive inspection (TM 1-1520-264-23).

**c. When disassembled, rack inspection area shall be mounting area around pivot point, extending outward four inches onto rack surface. Inspection shall be performed internally and externally.**

**d. Check wire harness for broken or frayed wires; loose or damaged connections, and loose, damaged, or missing clamps** (TM 55-1500-323-24).

**e. Check aerial bracket for cracks.** None allowed.

GO TO NEXT PAGE

## 16.1. PYLON INSPECTION - continued

- f. **Check circuit card for broken wires, connectors, or clamps** (TM 55-1500-323-24).

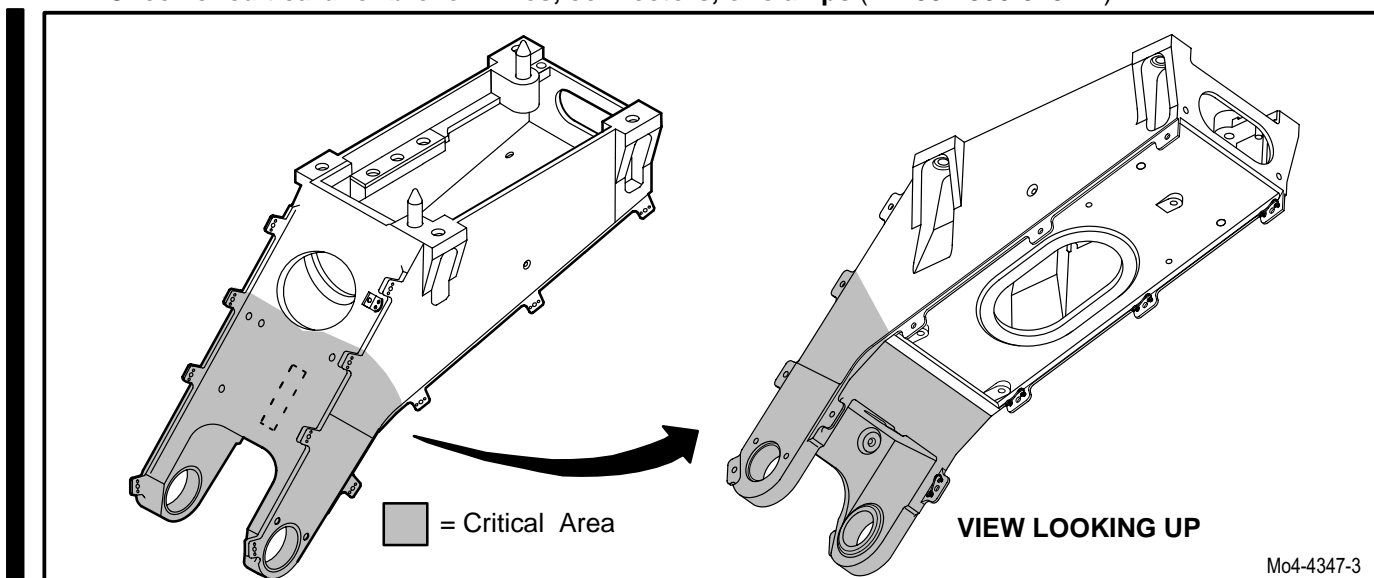

- g. **Check ejector for actuation.** Ensure ejector rod is not extended and jettison cartridges are not fired. Disassemble/assemble ejector, if fired (para 16.7).
- h. **Check ejector assembly for cracks. Use magnifier.** None allowed. If cracks are suspected, perform nondestructive inspection (TM 1-1520-264-23).
- i. **Check MRTU bracket for cracks or weld separation in corners. Use magnifier.** None allowed. If cracks are suspected, perform nondestructive inspection (TM 1-1520-264-23).
- k. **Check stow bracket for cracks.** None allowed. Ensure release mechanism is functioning. Check chain for damage. None allowed.
- l. **Check stow bracket receptacles for cracks, damaged keyways or stripped threads** (TM 55-1500-323-24). No cracks allowed. Thread damage not to exceed 50 percent of one thread.
- m. **Check nutplates and fastener receptacles for damage** (TM 1-1500-204-23).
- n. **Check all components for loose, damaged, or missing hardware.** None allowed.
- o. **Check pylon actuator for leaks or seepage.** Leaks shall not exceed three drops per packing per 25 cycles of operation. No other leakage permitted (para 7.2).
- p. **Check for chafed, cracked, dented, nicked, and scored tubes** para 7.56

GO TO NEXT PAGE

**16.1. PYLON INSPECTION - continued**

- p. **Check pylon rack for allowable release torque** (para 16.2).
- q. **Check pylon stores jettison cartridges for damage.** Ensure CCU-44/B cartridges are installed (TM 43-0001-39).
- r. **Check pylon, pylon rack, and attached components for corrosion** (para 1.49).

**NOTE**

Pylon rack mounting bushings are located where the pivot pin is inserted through the pylon, which holds the pylon rack in position.

- s. **Check pylon rack mounting bushings for damage.**
  - (1) Measure inner diameter (ID) of bushing. ID measurement not to exceed **1.438 INCHES** or out of round by no more than **0.001 INCH**. If ID does not meet specifications, replace bushing (TM 55-1500-322-24). Use caliper set.
  - (2) Check bushing for gouges and scratches. Gouges and scratches will be no more than 30 percent of the hollow pin interface surface area. If gouges and scratches exceed 30 percent, replace bushing (TM 55-1500-322-24).

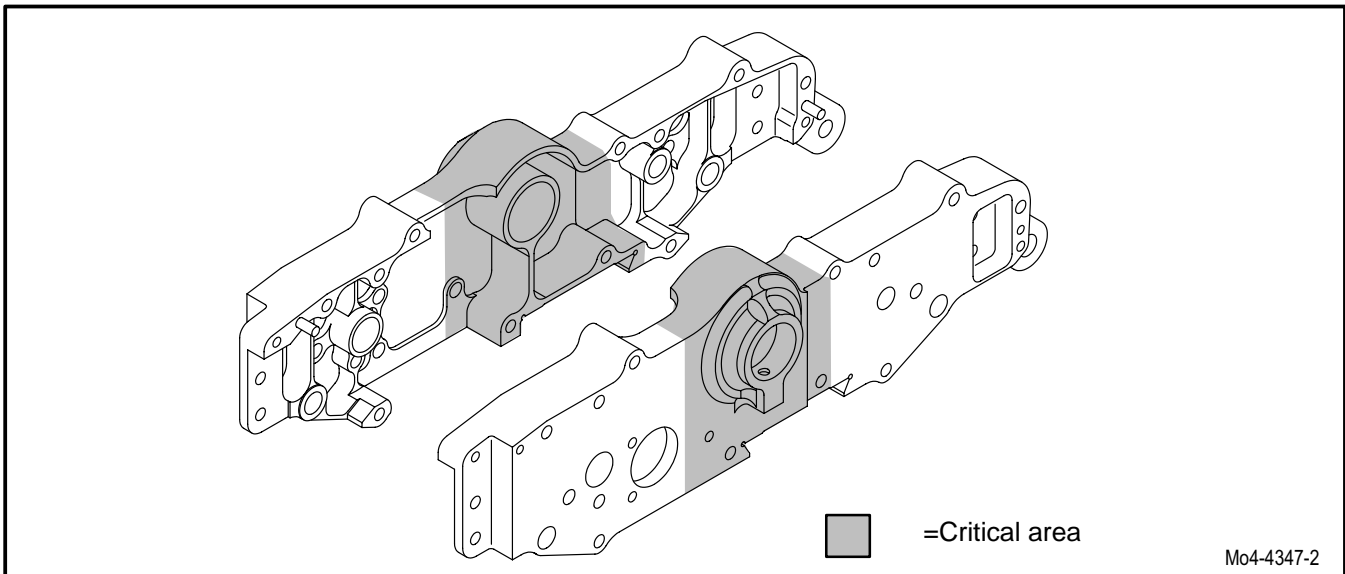

- t. **Check pylon rack articulation.**
  - (1) Disconnect actuator rod end from yoke of pylon rack (para 16.25).
  - (2) Rotate the pylon rack about the hollow pin. The pylon rack must rotate freely and smoothly with less than **15 POUNDS** of load applied by hand on the yoke at the aft end of the pylon rack. Use spring tester.
  - (3) If pylon rack requires less than **15 POUNDS** of load to move, and moves smoothly and quietly, connect rod end (para 16.25).

GO TO NEXT PAGE

---

**16.1. PYLON INSPECTION - continued**

---

- (4) If pylon rack requires **15 POUNDS** or more of load to rotate around the hollow pin, or is noisy (squeaks), or shows signs of binding or gritty action, remove pylon rack (para 16.4). Inspect hollow pin and two bushings for any signs of distress or material transfer. If present, replace hollow pin (para 16.4).
- (5) If there are no signs of distress or material transfer, connect rod end and reinstall pylon rack (para 16.25 and para 16.4).

END OF TASK

**16.2. PYLON REMOVAL/INSTALLATION**

16.2.1. Description

This task covers: Removal. Cleaning. Inspection. Installation.

16.2.2. Initial Setup

**Tools:**

- Electrical tool kit (item 378, App H)
- Light duty laboratory apron (item 27, App H)
- Chemical protective gloves (item 154, App H)
- Adjustable air filtering respirator (item 262, App H)
- 30 - 150 inch-pound 1/4-inch drive click type torque wrench (item 435, App H)
- 150 - 750 inch-pound 3/8-inch drive click type torque wrench (item 442, App H)

**References:**

- TM 1-1520-238-T
- TM 1-1500-204-23
- TM 9-1090-208-23
- TM 9-1427-475-20
- TM 9-1230-476-20-1
- TM 55-1500-345-23

**Materials/Parts:**

- Cloth (item 52, App F)
- Hydraulic fluid (item 92, App F)
- Isopropyl alcohol (item 106, App F)
- Pad (item 130, App F)

**Equipment Conditions:**

**Personnel Required:**

- 68X Armament/Electrical System Repairer  
Two persons to assist
- 68X3F Armament/Electrical System Repairer/  
Technical Inspector

<u>Ref</u>	<u>Condition</u>
1.57	Helicopter safed
16.3	Pylon rack ejector impulse cartridge removed
7.57	Utility hydraulic system vented

**NOTE**

- This task is typical for all four pylons.
- Before pylon is returned to depot, remove multiplex remote terminal unit (MRTU) (TM 9-1230-476-20-1).

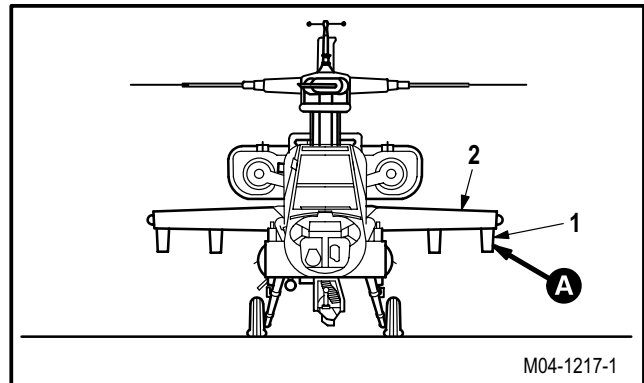

GO TO NEXT PAGE

---

**16.2. PYLON REMOVAL/INSTALLATION - continued**

---

**16.2.3. Removal****a. Remove pylon (1) from wing (2).**

- (1) Support pylon (1) under wing (2).
- (2) Remove four bolts (3) that secure pylon (1) to wing (2).
- (3) Slowly lower pylon (1) straight down from wing (2).

**16.2.4. Cleaning**

- a. **Wipe pylon and mounting area.** Use cloth (item 52, App F).

**16.2.5. Inspection**

- a. **Check mounting area, actuator and top plate assembly, rack, pins, and fairings for cracks and warps.** None allowed.
- b. **Check connector for cracks, broken pins, or damaged wiring connections** (para 16.1).
- c. **Check packing and retainer inside of wing hydraulic coupling quick disconnect (female half) for cuts or deterioration.** None allowed.
  - (1) If packing and/or retainer are found damaged, replace both parts (TM 1-1500-204-23).
  - (2) If wing hydraulic coupling quick disconnect is found damaged, replace quick disconnect (para 7.100).
- d. **Check pylon for loose or missing hardware** (para 16.1).

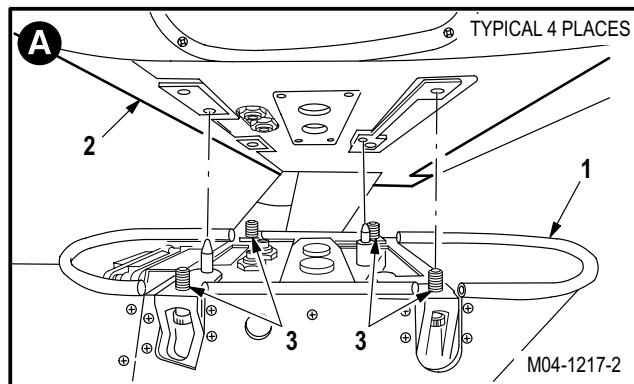

GO TO NEXT PAGE

16.2. PYLON REMOVAL/INSTALLATION - continued

e. Check pylon rack hooks for allowable release torque.

- (1) Position rack hooks to the indicated HOOK-LOCKED position.
- (2) Move rack hooks to the indicated HOOK-UNLOCKED position. Use torque wrench. Note torque reading at release point.
- (3) Rack is operational if torque reading is less than **120 INCH-POUNDS**. Repair rack if torque reading to open rack hooks is greater than **120 INCH-POUNDS** (para 16.5).

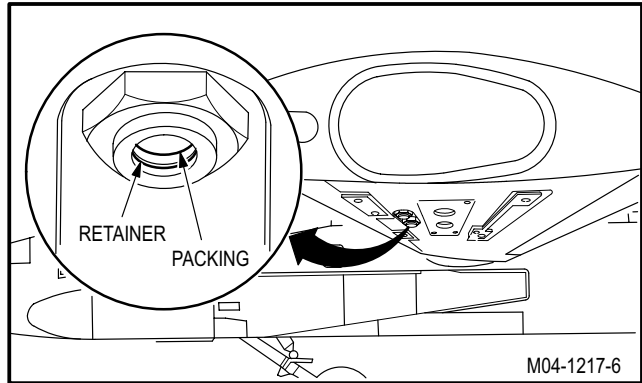

f. Check all components for corrosion; paying particular attention to suspension hook, hollow pivot pin, actuator shaft bearing nut, inner and outer shell surfaces (para 1.49).

- (1) Unpitted surface corrosion is acceptable if it can be removed with a scouring pad. Use pad (item 130, App F). Refinish cleaned parts (TM 55-1500-345-23).
- (2) Corrosion pits are unacceptable. Replace parts that have corrosion pits.
- (3) Replace steel parts that have pitted or broken cadmium plating.

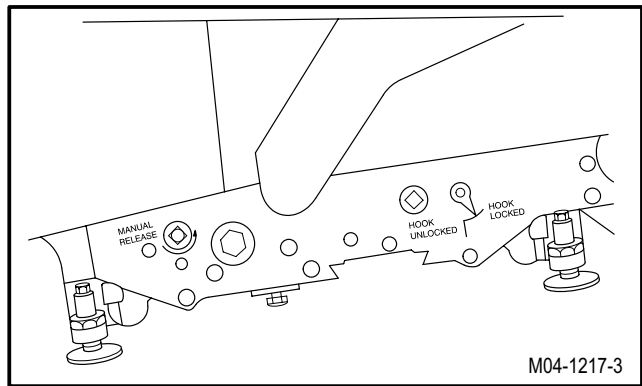

16.2.6. Installation



a. Just before installing pylon (1), clean and lubricate mating surface of hydraulic couplings female half (4) and male half (5).

- (1) Clean mating surfaces of hydraulic couplings female half (4) and male half (5). Use cloth (item 52, App F) dampened with isopropyl alcohol (item 106, App F).

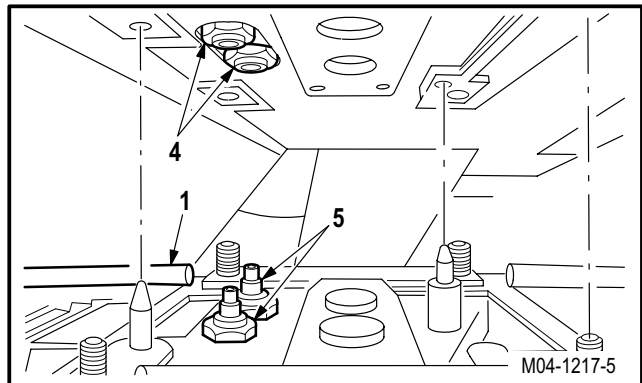

GO TO NEXT PAGE



## 16.2. PYLON REMOVAL/INSTALLATION - continued

- (2) Apply hydraulic fluid to mating surfaces of hydraulic couplings female half (4) and male half (5). Use hydraulic fluid (item 92, App F). Ensure packings (6) and retainer (7) are completely lubricated before installing pylon.

### CAUTION

Connector pin damage will occur if an AH-64D pylon is installed on an AH-64A wing. To prevent damage to the pylon and wing connector, ensure the pylons are AH-64A configuration prior to installation.

- b. **Install pylon (1) on wing (2).** Torque four bolts (3) to **650 INCH-POUNDS**.

- (1) Lift pylon (1) straight up and position under wing (2).
- (2) Aline two straight pins (8) and four bolts (3) with mounting holes in wing (2).
- (3) Install two of the four bolts (3) diagonally from each other, then install the two remaining bolts (3).
- (4) Torque four bolts (3) to **650 INCH-POUNDS**. Use torque wrench.

- c. **Inspect (QA).**

- d. **Perform utility hydraulic system bleeding operation** (para 1.35).

- e. **Perform utility hydraulic system servicing operation** (para 1.34).

- f. **Perform external stores elevation control maintenance operational check** (TM 1-1520-238-T).

- g. **Perform external stores jettison maintenance operational check** (TM 1-1520-238-T).

- h. **Perform pylon boresighting** (TM 9-1230-476-20-1).

- i. **Install pylon rack ejector impulse cartridge** (para 16.3).

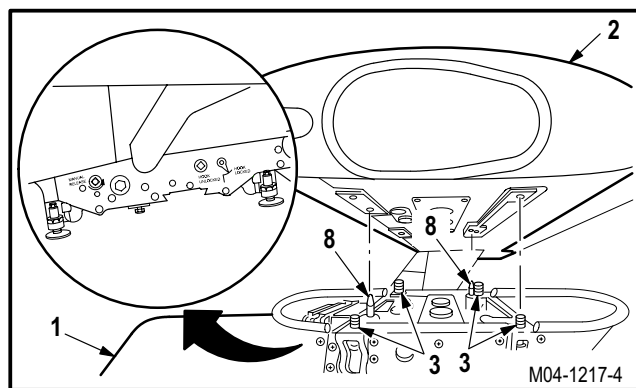
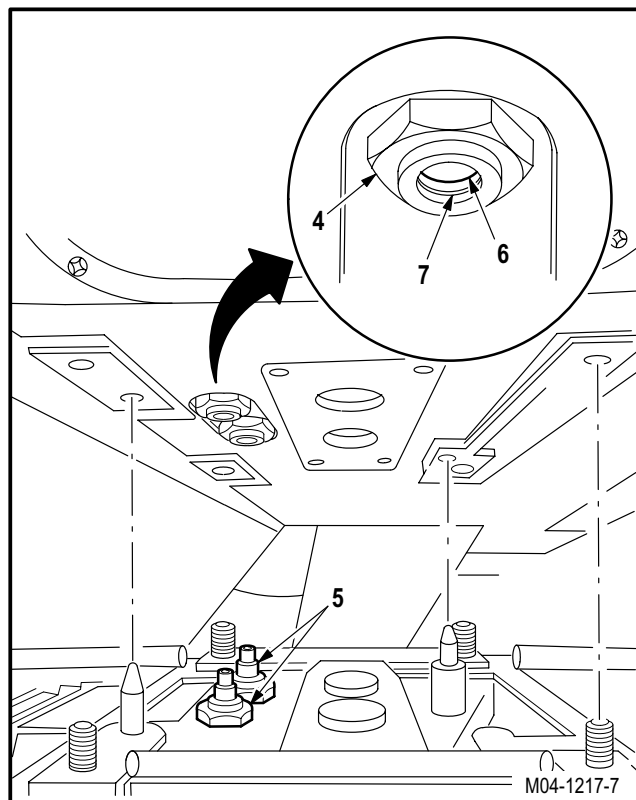

END OF TASK

### 16.3. PYLON RACK EJECTOR IMPULSE CARTRIDGE REMOVAL/INSTALLATION

#### 16.3.1. Description

This task covers: Removal. Cleaning. Inspection. Installation.

#### 16.3.2. Initial Setup

##### Tools:

Aircraft maintenance tool kit (item 373, App H)  
 Electrical tool kit (item 378, App H)  
 Multimeter (item 215, App H)  
 30 - 150 inch-pound 1/4-inch drive click type torque wrench (item 435, App H)  
 150 - 750 inch-pound 3/8-inch drive click type torque wrench (item 442, App H)

##### Materials/Parts:

Marker (item 123, App F)  
 Wire (item 224, App F)

##### Personnel Required:

68X Armament/Electrical System Repairer  
 Two persons to assist  
 68X3F Armament/Electrical System Repairer/  
 Technical Inspector

##### References:

TM 9-1300-206

##### Equipment Conditions:

<u>Ref</u>	<u>Condition</u>
1.57	Helicopter safed

#### WARNING

**Ensure all helicopter safing procedures are accomplished. Observe all safety precautions during maintenance. Failure to do so could result in death or serious injury. If injury occurs, seek medical aid.**

#### NOTE

This task is typical for all four pylons.

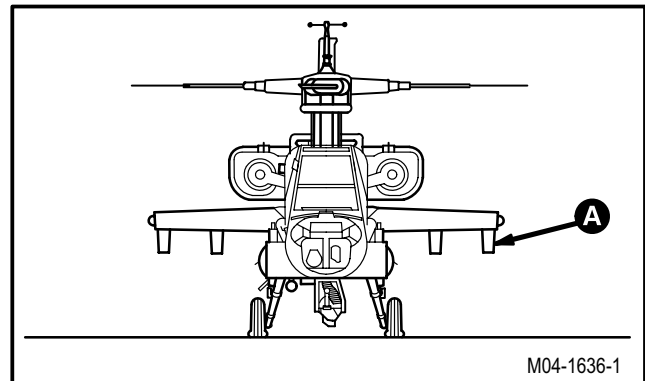

#### 16.3.3. Removal

- a. **Enter pilot station (para 1.56). Observe all safety precautions.**
- b. **On pilot forward circuit breaker panel, open MISSION JETT, MISSION ARM CONTR, and MISSION RKT ELEX circuit breakers.**
- c. **On pilot center circuit breaker panel, open JETT circuit breaker.**

GO TO NEXT PAGE

16.3. PYLON RACK EJECTOR IMPULSE CARTRIDGE REMOVAL/INSTALLATION - continued

- d. Verify that safety pin (1) is installed in pylon rack (2).

**WARNING**

Static electricity can accidentally fire ejection cartridge. To prevent possible injury to personnel or cause damage to equipment, do not touch cartridge primer. If injury occurs, seek medical aid.

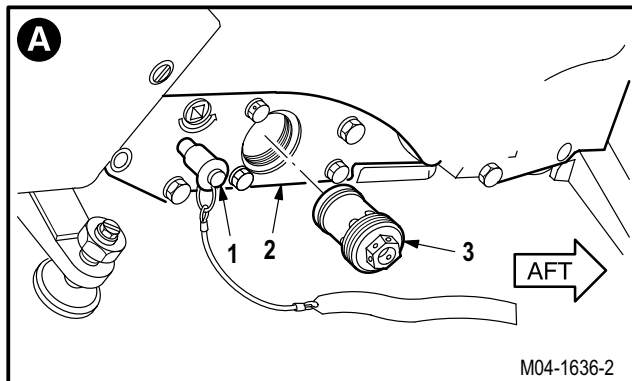

- e. Remove housing (3) from rack (2).

- (1) Remove lockwire from housing (3).
- (2) Unscrew housing (3) from rack (2).

- f. Remove cartridge (4) from housing (3). Do not touch primer (5).

- (1) Remove cartridge (4) out of housing (3). Do not touch primer (5).
- (2) Place cartridge (4) in storage container (6) (TM 9-1300-206).

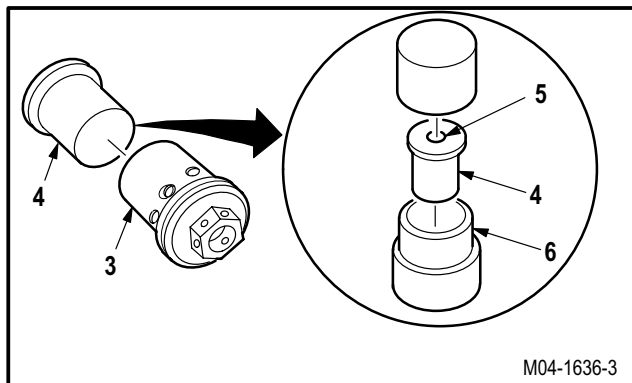

16.3.4. Cleaning

**NOTE**

Anytime stores are jettisoned, clean and inspect jettison rack (para 16.7).

- a. **Wipe impulse cartridge mounting area with a clean rag.**

16.3.5. Inspection

- a. **Check cartridge mounting area for cracks** (para 16.1).
- b. **Check cartridge mounting area for corrosion** (para 1.49).

GO TO NEXT PAGE

16.3. PYLON RACK EJECTOR IMPULSE CARTRIDGE REMOVAL/INSTALLATION - continued

16.3.6. Installation

**NOTE**

- If housing is to be installed with a cartridge, perform steps b., c., and d. only. If housing and cartridge are to be installed, perform steps b. through o.
- If housing is to be installed without a cartridge, perform step a only. Cartridge housing is to be installed in reverse position, for safety.

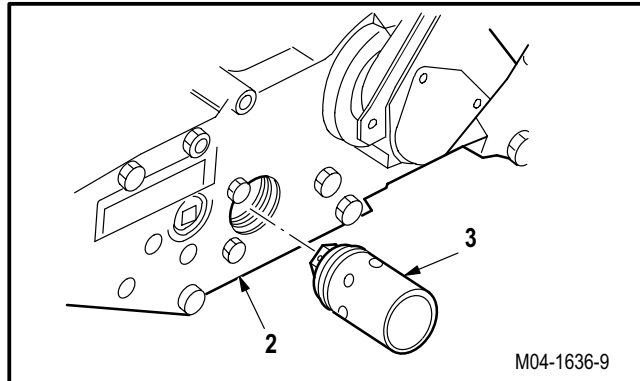

- a. **Install housing (3) 180° in reverse position, to show no cartridge installed.**
- b. **Install housing (3) in rack (2).** Torque housing (3) to **85 INCH-POUNDS**.
- c. **Lockwire housing (3) to ejector bolt (12).** Use wire (item 224, App F).
- d. **Inspect (QA).**
- e. **Calibrate and install ejector test set (7)** (para 16.8).
- f. **Check test set indicator (8) for allowable contact pin length.** Indicator should read between **0.025** and **0.065 INCH**.
- g. **Replace contact pin if indicator (8) does not read between 0.025 and 0.065 INCH** (para 16.19).
- h. **Check for static electricity in rack (2).**
  - (1) Insert multimeter positive lead (9) in test set meter jack (10). Use multimeter.
  - (2) Place multimeter negative lead (11) on any helicopter ground.
  - (3) Check for voltage on multimeter. Repeat step h if voltage is present. If voltage is not present go to step i.
- i. **Remove ejector test set from pylon rack** (para 16.8).

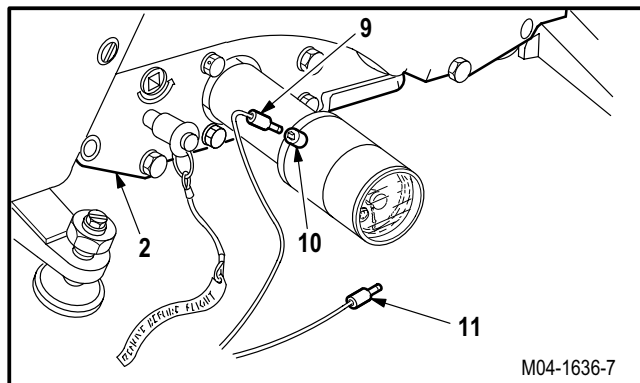
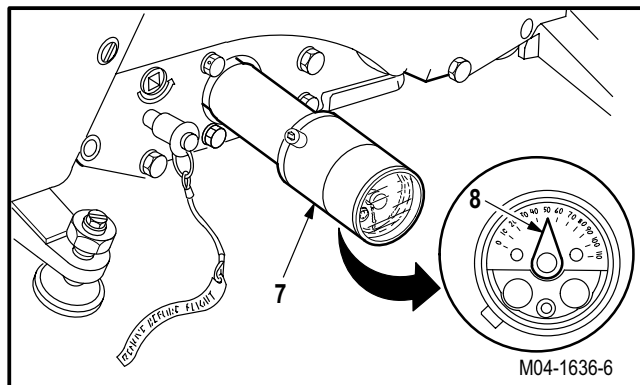
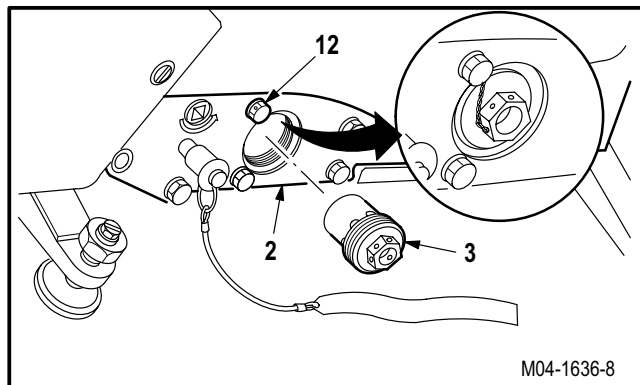

GO TO NEXT PAGE

16.3. PYLON RACK EJECTOR IMPULSE CARTRIDGE REMOVAL/INSTALLATION - continued

**WARNING**

Static electricity can accidentally fire ejection cartridge. To prevent possible injury to personnel or cause damage to equipment, do not touch cartridge primer. If injury occurs, seek medical aid.

**CAUTION**

To prevent external stores jettison system malfunction, do not install or use damaged cartridges.

**NOTE**

Use CCU-44/B cartridge only.

- j. Remove cartridge (4) from container (6). Do not touch primer (5).
- k. Install cartridge (4) in housing (3). Do not touch primer (5).

(1) Mark installation date on cartridge (4). Use marker (item 123, App F)

- l. Install housing (3) with cartridge (4) in rack (2). Torque housing (3) to **225 INCH-POUNDS**. Use torque wrench.

- m. Lockwire housing (3) to ejector bolt (12). Use wire (item 224, App F).

**NOTE**

Monitor service life by expiration date or 36 months after installation, whichever occurs first.

- n. Record installation date in appropriate log-books.
- o. Inspect (QA).

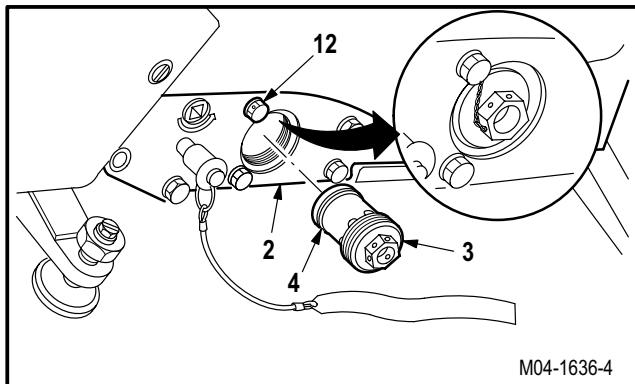
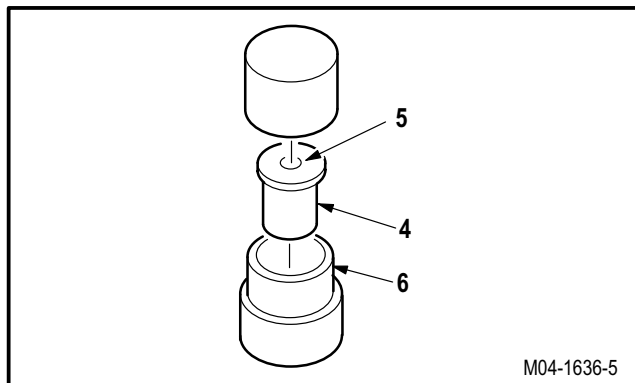

END OF TASK

## 16.4. PYLON RACK REMOVAL/INSTALLATION

### 16.4.1. Description

This task covers: Removal. Cleaning. Inspection. Installation.

### 16.4.2. Initial Setup

#### Tools:

Electrical tool kit (item 378, App H)  
 Light duty laboratory apron (item 27, App H)  
 0.000 - 6.000-inch outside micrometer caliper set (item 52, App H)  
 Chemical protective gloves (item 154, App H)  
 5X & 12X monocular magnifier (item 206, App H)  
 Adjustable air filtering respirator (item 262, App H)  
 0 - 30 inch-pound 1/4-inch drive dial indicator torque wrench (item 445, App H)  
 0 - 75 inch-pound 1/4-inch drive dial indicator torque wrench (item 446, App H)  
 0 - 600 inch-pound 3/8-inch drive dial indicator torque wrench (item 447, App H)

#### Materials/Parts:

Antiseize compound (item 26, App F)  
 Adhesive (item 14, App F)  
 Corrosion preventive compound (item 63, App F)  
 Strap (item 193, App F)  
 Wire (item 224, App F)

#### Personnel Required:

68X Armament/Electrical System Repairer  
 One person to assist  
 68X3F Armament/Electrical System Repairer/  
 Technical Inspector

#### References:

TM 1-1520-238-T  
 TM 55-1500-323-24

#### Equipment Conditions:

<u>Ref</u>	<u>Condition</u>
1.57	Helicopter safed
2.2	Pylon fairing P1 removed
16.3	Pylon rack ejector impulse cartridge removed
16.9	Actuator rod end detached

### NOTE

This task is typical for all four pylons.

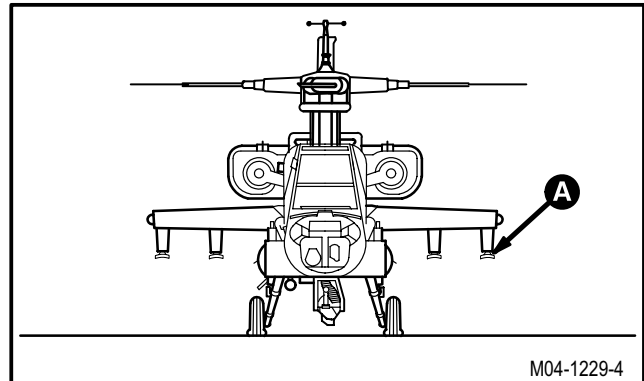

M04-1229-4

GO TO NEXT PAGE

---

**16.4. PYLON RACK REMOVAL/INSTALLATION - continued**

---

**16.4.3. Removal**

- a. **Detach connector P511 (1) from dummy receptacle J511 (2) on pylon stow bracket (3).**

(1) Pull lanyard (4) to release connector (1).

- b. **Detach connector P512 (5) from dummy receptacle J512 (6) on bracket (3).**

(1) Pull lanyard (7) to release connector (5).

- c. **Detach connector P513 (8) from dummy receptacle J513 (9) on bracket (3).**

(1) Pull lanyard (10) to release connector (8).

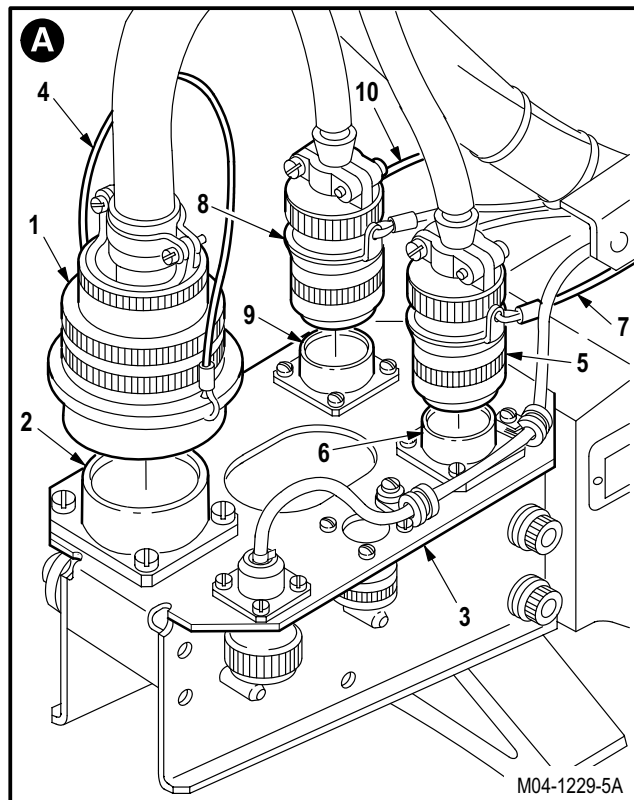
**NOTE**

Identify each wire and terminal during removal for proper placement during installation.

- d. **Remove wire harness (11) from bracket (3).**

(1) Remove tie strap (12) from receptacle J256 (13).

(2) Depin and identify wires (14) and (15) from receptacle J256 (13) (TM 55-1500-323-24).

(3) Remove two screws (16), washers (17), and clamps (18) from bracket (3).

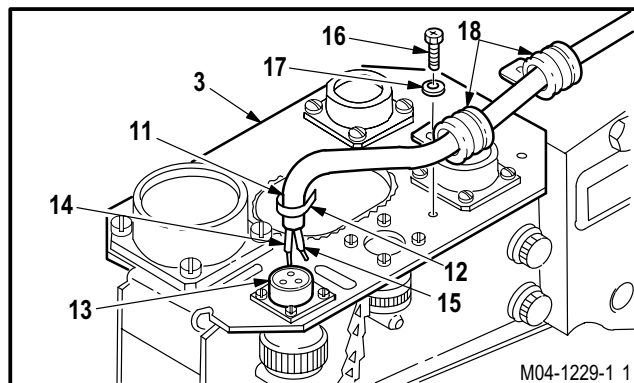

GO TO NEXT PAGE

16.4. PYLON RACK REMOVAL/INSTALLATION - continued

e. Remove wire harnesses (19) and (20) from support clamp (21).

- (1) Remove screw (22) and washer (23) from bracket (24).

**NOTE**

Identify each wire and terminal during removal for proper placement during installation.

f. Identify and depin wires (19) and (20) from TB1 (25) and TB2 (26) (TM 55-1500-323-24).

g. Remove bonding jumper (27) from pylon rack (28).

- (1) Remove nut (29), washer (30), jumper (27), and electrical lead (31).

**NOTE**

- If pylon rack load sharing tie per MWO 1-1520-238-55-TBD (AED) perform steps j and k to remove pylon rack.
- If pylon rack is not modified (AEC) perform steps h and i to remove pylon rack.

h. Remove hollow pin (32) from rack (28) and frame (33).

- (1) Remove sealant from cover plate (34).
- (2) Remove two screws (35), washers (36), and plate (34).
- (3) Remove lockwire from two pins (37).
- (4) Remove two pins (37) from rack (28).
- (5) Remove pin (32).

i. Remove rack (28) from frame (33).

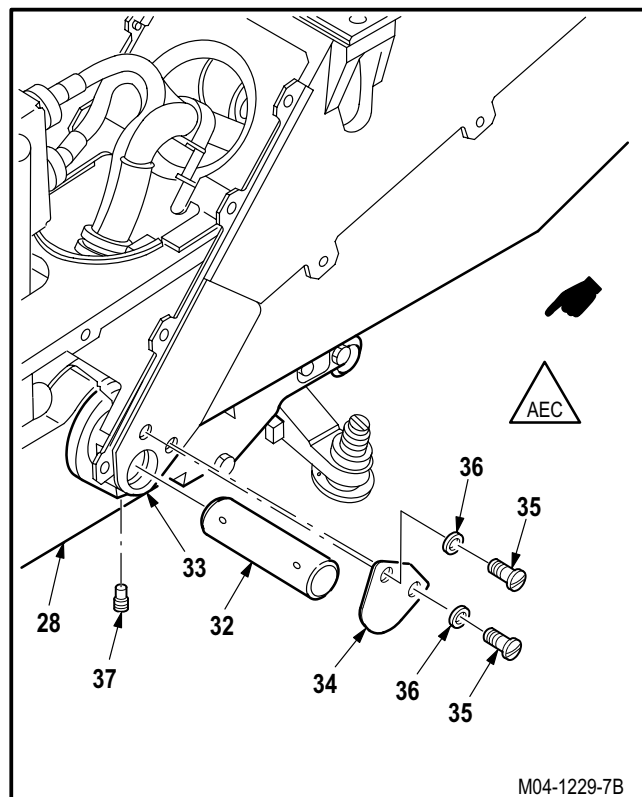
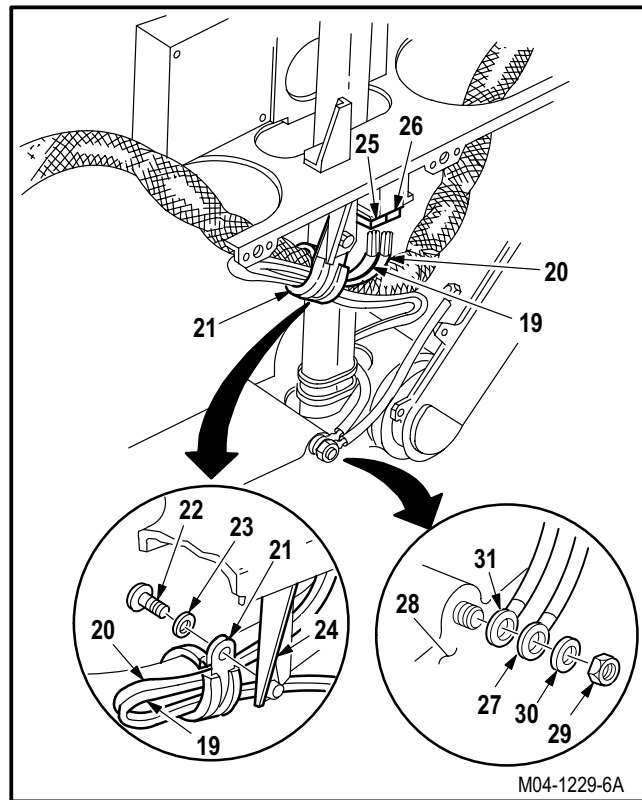

GO TO NEXT PAGE



## 16.4. PYLON RACK REMOVAL/INSTALLATION

### j. Remove hollow pin (32) and load sharing tie (37.1) from rack (28) and frame (33).

- (1) Remove lockwire from two endcaps (37.3).
- (2) Remove endcap (37.3) from load sharing tie (37.1).
- (3) Remove load sharing tie (37.1) and endcap (37.3) from frame (33).
- (4) Remove endcap (37.3) from load sharing tie (37.1).
- (5) Remove sealant from two end plates (37.2).
- (6) Remove four screws (35) and washers (36) from two endplates (37.2). Remove two endplates (37.2) from frame (33).
- (7) Remove lockwire from two pins (37).
- (8) Remove two pins (37) from rack (28).
- (9) Remove hollow pin (32) from rack (28) and frame (33).

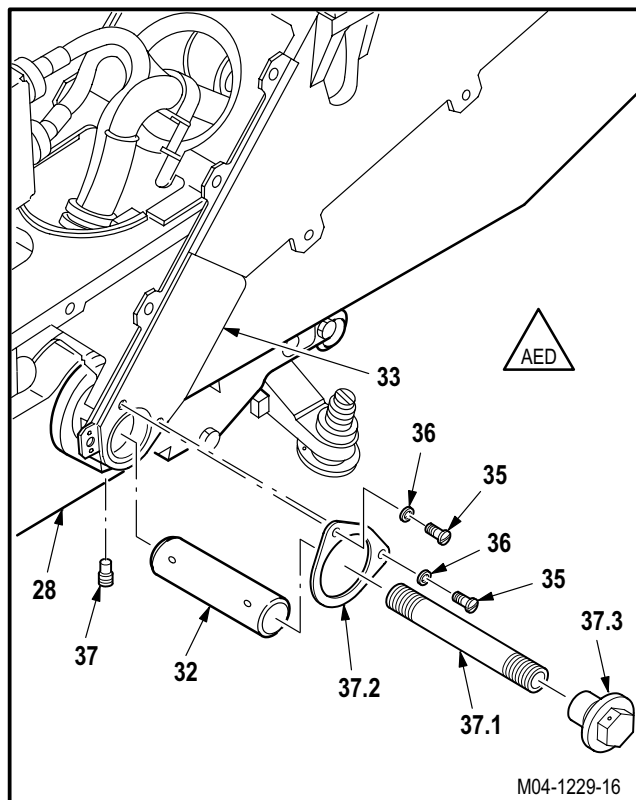

### k. Remove rack (28) from frame (33).

#### 16.4.4. Cleaning

- a. **Wipe pylon rack and mounting area with a clean rag.**

#### 16.4.5. Inspection

- a. **Check pylon rack and mounting area for cracks.** (para 16.1).
- b. **Check pylon hollow pin for damage** (para 16.1).
- c. **Check mounting area around pivot point** (para 16.1).
- d. **Check bonding cable for fraying and /or cuts.** No more than 25 percent of original cable can be frayed or cut.
- e. **Check bonding cable for damaged or missing heat shrink between terminal ends and sleeve.** None allowed. Install or replace heat shrink (TM 55-1500-323-24).
- f. **Check pylon rack and mounting area for corrosion** (para 1.49).
- g. **Check pylon rack inserts, bushings, and bearings for visible damage** (para 16.1).
- h. **Check connectors P511, P512, and P513 for backshell screw torques.** Torque should be **8 INCH-POUNDS**. Use torque wrench.

GO TO NEXT PAGE

**16.4. PYLON RACK REMOVAL/INSTALLATION - continued**

16.4.6. Installation

a. **Install rack (28) on frame (33).** Torque two pins (37) to **50 INCH-POUNDS**.

- (1) Aline rack (28) with frame (33).
- (2) Install hollow pin (32).
- (3) Aline two holes (39) in pin (32) with two holes (38) rack (28). Install two pins (37).
- (4) Torque two pins (37) to **50 INCH-POUNDS**. Use torque wrench.
- (5) Lockwire two pins (37) to rack (28). Use wire (item 224, App F).

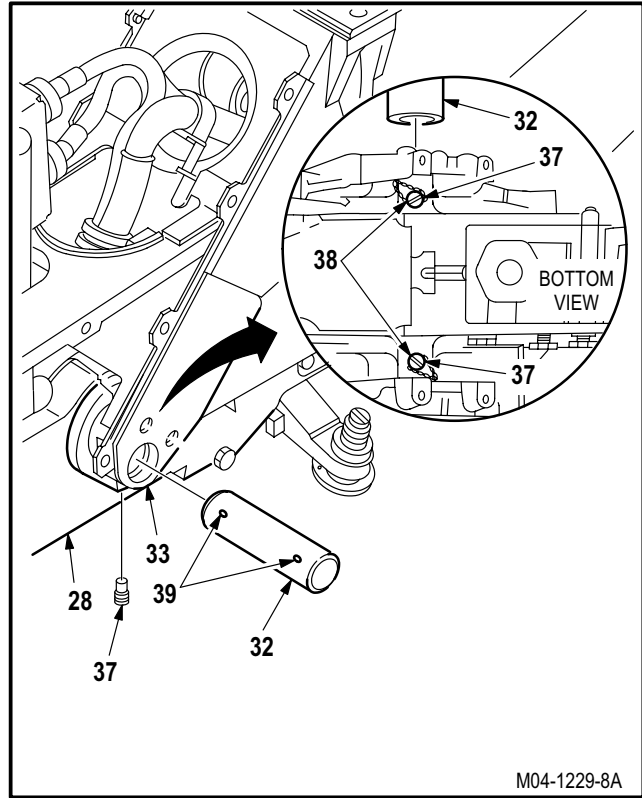

b. **Attach electrical lead (31) and jumper (27) to rack (28).**

- (1) Install electrical lead (31), jumper (27), washer (30), and nut (29).

c. **Secure wire harnesses (19) and (20).**

- (1) Position clamp (21) on wires (19) and (20).
- (2) Install screw (22) through washer (23) and clamp (21) into bracket (24).

d. **Attach wires of wire harnesses (19) and (20) to TB1 (25) and TB2 (26).**

- (1) Pin identified wires of wire harness (19) to TB1 (25) (TM 55-1500-323-24).
- (2) Pin identified wires of wire harness (20) to TB2 (26) (TM 55-1500-323-24).

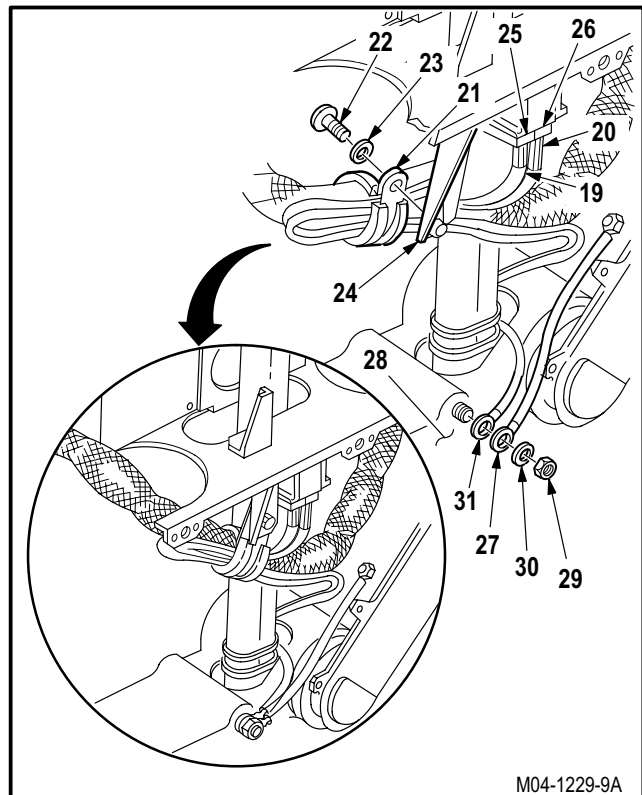

GO TO NEXT PAGE

**16.4. PYLON RACK REMOVAL/INSTALLATION - continued**

**e. Install harness (11) on bracket (3).**

- (1) Install tie strap (12) on harness (11) at receptacle (13). Use strap (item 193, App F).
- (2) Install two screws (16) through washers (17) and clamp (18) into bracket (3).
- (3) Pin two identified wires (14) and (15) of wire harness (11) to receptacle J256 (13) (TM 55-1500-323-24).

**f. Attach connector P513 (8) to receptacle J513 (9).**

**g. Attach connector P512 (5) to receptacle J512 (6).**

**h. Attach connector P511 (1) to receptacle J511 (2).**

**i. Check pylon rack articulation.**

- (1) Disconnect actuator rod end from yoke of pylon rack (para 16.25).
- (2) Rotate the pylon rack about the hollow pin. The pylon rack must rotate freely and smoothly with less than **15 POUNDS** of load applied by hand on the yoke at the aft end of the pylon rack. Use spring tester.
- (3) If pylon rack requires less than **15 POUNDS** of load to move and moves smoothly and quietly, connect rod end (para 16.25).
- (4) If pylon rack requires **15 POUNDS** or more of load to rotate around the hollow pin, or is noisy (squeaks), or shows signs of binding or gritty action, remove pylon rack (para 16.4). Inspect hollow pin and two bushings for any signs of distress or material transfer. If present, replace hollow pin (para 16.4).
- (5) If there are no signs of distress or material transfer, connect rod end and reinstall pylon rack (para 16.25 and para 16.4).

**j. Check rack hooks (39) and (40) for allowable release torque.**

- (1) Position rack hooks (39) and (40) to **HOOK-LOCKED** position (41).

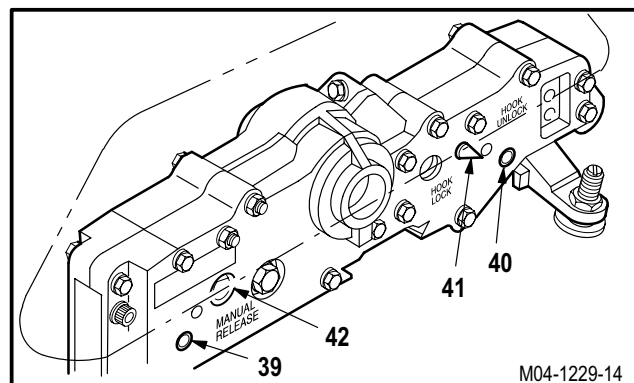
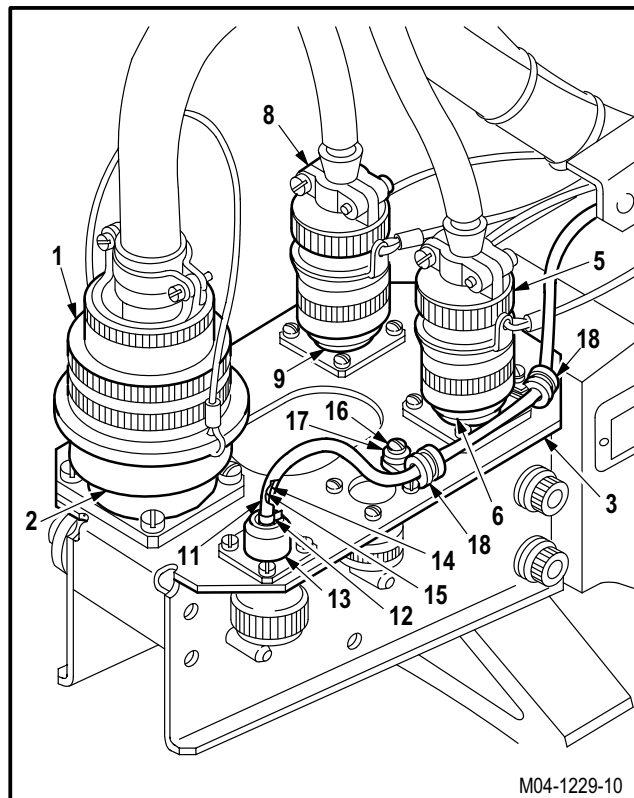

GO TO NEXT PAGE

---

**16.4. PYLON RACK REMOVAL/INSTALLATION - continued**

---

- (2) Position torque wrench in **MANUAL RELEASE** fitting (42) and move hooks to **HOOK-UNLOCKED** position (41). Note torque reading at release point.
- (3) Rack is operational if torque reading is less than **120 INCH-POUNDS**. Repair rack if torque reading to open rack hooks is greater than **120 INCH-POUNDS** (para 16.5).

**k. Inspect (QA).**

**l. Attach actuator rod end** (para 16.9).

**m. Perform external stores jettison maintenance operational check** (TM 1-1520-238-T).

**n. Install pylon fairing P1** (para 2.2).



**CAUTION**

Do not apply corrosion preventive compound on individual components after or during assembly. Application will result in wet (lubricated) torque which can result in a much higher torque value than specified.

**NOTE**

- Do not use corrosion preventive film on weapons pylons (Teflon coated) pivot pins, part number 7-318000061-3.
- New pylon rack initially requires two applications of corrosion preventive compound, which must be applied in intervals at least one hour apart.
- When applying corrosion preventive compound, use the precision (straw-like) applicator attached to the spray head of aerosol can.
- After two minutes, wipe excess corrosion preventive compound from applied area.

GO TO NEXT PAGE

16.4. PYLON RACK REMOVAL/INSTALLATION - continued

o. **Apply corrosion preventive compound to pylon rack pivot points.** Use corrosion preventive compound (item 63, App F). Make application in single short duration squirts, to the following areas.

- (1) Forward hook shaft (39) inboard and outboards sides of rack (28).
- (2) Aft hook shaft (40) inboard and outboard sides of rack (28).
- (3) MANUAL RELEASE pivot point (41) inboard and outboard sides of rack (28).
- (4) HOOK-LOCK/HOOK-UNLOCK indicator pivot point (43) inboard and outboard sides of rack (28).
- (5) Pylon rack pivot (43) between rack support and rack (28).

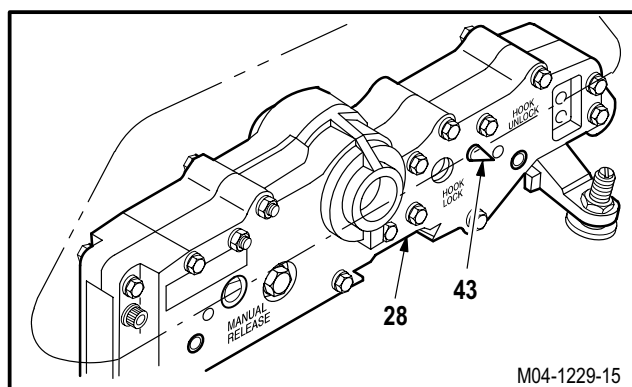
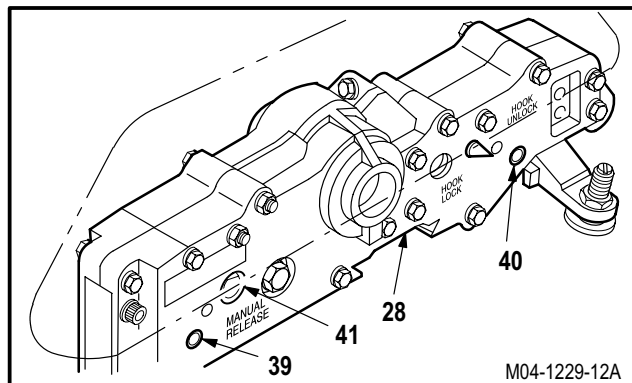

**NOTE**

- If pylon rack load sharing tie per MWO 1-1520-238-55-TBD (AED) perform step q to remove pylon rack.
- If pylon rack is not modified (AEC) perform step p remove pylon rack.



p. **Install cover plate (34).**

- (1) Apply adhesive to mating surface of plate (34). Use adhesive (item 14, App F).
- (2) Install two screws (35) through washers (36) and plate (34) into frame (33).
- (3) Apply continuous bead of adhesive to edge of seal plate (34). Use adhesive (item 14, App F).

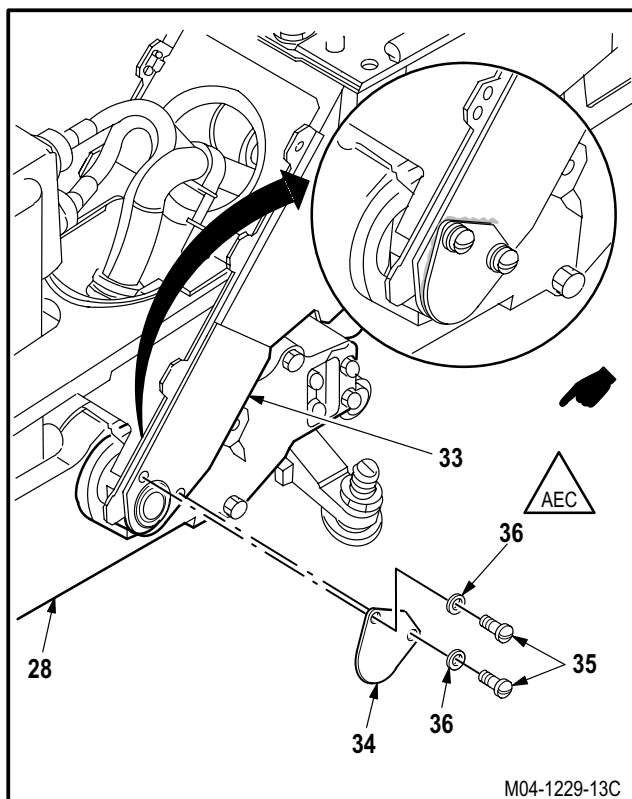

GO TO NEXT PAGE

16.4. PYLON RACK REMOVAL/INSTALLATION - continued

q. Install load sharing tie (37.1) in rack (28) and frame (33).

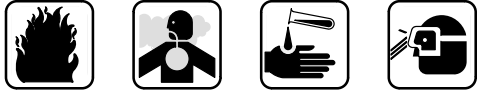

- (1) Apply adhesive to mating surface of end plates (37.2). Use adhesive (item 14, App F).
- (2) Install two screws (35) through washers (36) and end plates (37.2) into frame (33).
- (3) Apply continuous bead of adhesive to edge of end plates (37.2). Use adhesive (item 14, App F).
- (1) Apply antiseize compound to first endcap (37.3) and insert load sharing tie (37.1) until the load sharing tie (37.1) bottoms out in endcap (37.3). Use antiseize compound (item 26, App F)
- (2) Insert load sharing tie (37.1) through hollow pin (32).
- (3) Install second end cap (37.3) on load sharing tie (37.1).

**CAUTION**

While applying torque to the endcaps, ensure that free rotation of the rack is maintained. Over torque of the endcaps could result in excessive binding, and possible failure of the pylon.

- (4) Torque endcaps (37.3) in **10 INCH-POUND** increments. Torque endcaps to **100 INCH-POUNDS** or until rack (28) begins to bind. Back off torque until free rotation is achieved. Use torque wrench

r. Inspect (QA).

s. Install pylon rack ejector impulse cartridge (para 16.3).

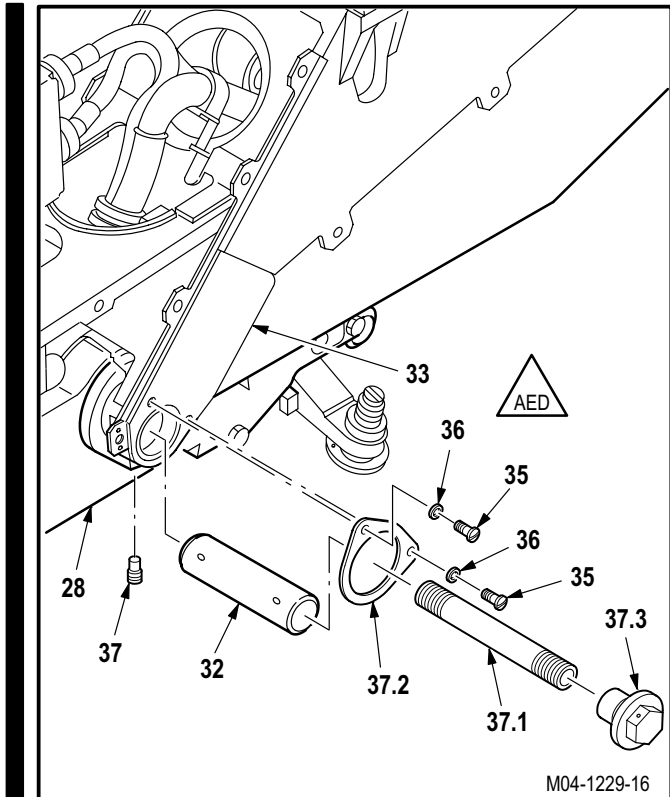

END OF TASK

---

**16.5. PYLON RACK DISASSEMBLY/ASSEMBLY (AVIM)**

---

16.5.1. Description

This task covers: Disassembly. Cleaning. Inspection. Repair. Assembly.

---

16.5.2. Initial Setup**Tools:**

Electrical tool kit (item 378, App H)  
 Light duty laboratory apron (item 27, App H)  
 Chemical protective gloves (item 154, App H)  
 ■ 5X & 12X monocular magnifier (item 206, App H)  
 10-ton hydraulic hand operated arbor press (item 236, App H)  
 Adjustable air filtering respirator (item 262, App H)  
 30 - 150 inch-pound 1/4-inch drive click type torque wrench (item 435, App H)  
 0 - 600 inch-pound 3/8-inch drive dial indicator torque wrench (item 447, App H)

**Personnel Required:**

68X Armament/Electrical System Repairer  
 68X3F Armament/Electrical System Repairer/  
 Technical Inspector

**Materials/Parts:**

Cotter pin (8)  
 Spring pin (4)  
 Corrosion preventive compound (item 63, App F)  
 Dry cleaning solvent (item 74, App F)  
 Epoxy primer coating kit (item 78, App F)  
 Grease (item 86, App F)

**References:**

TM 1-1500-204-23  
 TM 55-1500-345-23

---

16.5.3. Disassembly**NOTE**

Ensure pylon rack is set to HOOK UN-LOCKED.

a. **Remove HOOK LOCKED/HOOK UNLOCKED indicator (1).**

- (1) Remove screw (2), washer (3), and indicator (1) (two places).

**NOTE**

The pylon rack halves are matched set of mounting brackets and must be maintained and or replaced as such.

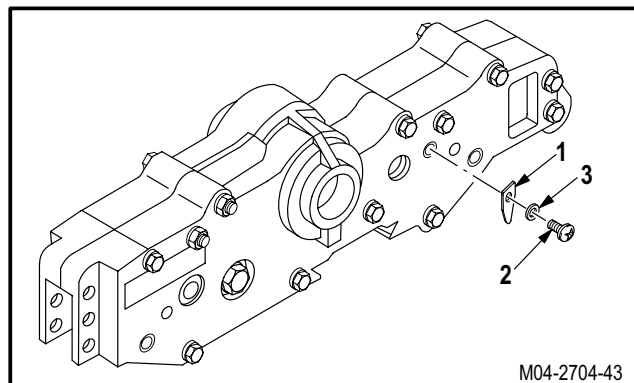

GO TO NEXT PAGE

16.5. PYLON RACK DISASSEMBLY/ASSEMBLY (AVIM) - continued

b. Separate pylon rack (4) into left mounting bracket (5) and right mounting bracket (6).

- (1) Remove three nuts (7) and washers (8) from bolts (9).
- (2) Remove three bolts (9) with washers (8).
- (3) Remove nut (7) and washer (8) from bolt (9)
- (4) Remove electrical leads (9.1) from bolt (9).
- (5) Remove bolt (9) and washer (8).
- (6) Remove nut (7) and washer (10) from bolt (11).
- (7) Remove bolt (11) with washer (10).
- (8) Remove six nuts (7) and washers (8) from bolts (12).
- (9) Remove six bolts (12) with washers (8).
- (10) Remove nut (13) with washer (14) from bolt (15).
- (11) Remove bolt (15) with washer (14).
- (12) Separate pylon rack (4) into left mounting bracket (5) and right mounting bracket (6) by tapping and prying evenly.

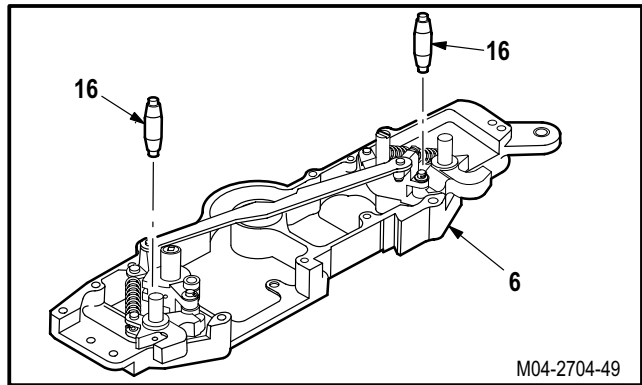
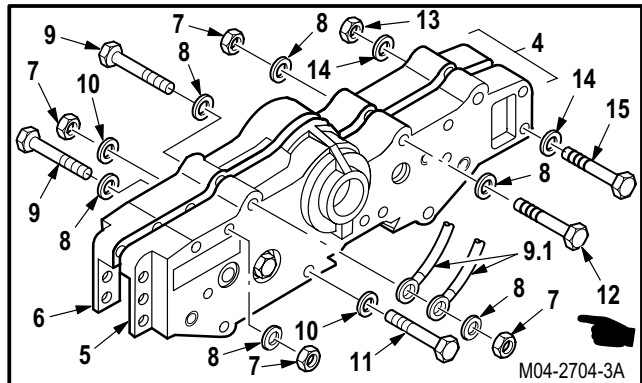

**NOTE**

The right mounting bracket contains the hook assemblies.

c. Remove two bumpers (16) from mounting bracket (6).

d. Install temporary cotter pin (17) through hole at end of rod (18) to retain springs (19) and (20) and spacer (21) on forward hook assembly (22) during removal.

- (1) Compress springs (19) and (20) until the hole in rod (18) is extended beyond pin (23).
- (2) Insert pin (17) through hole in rod (18).

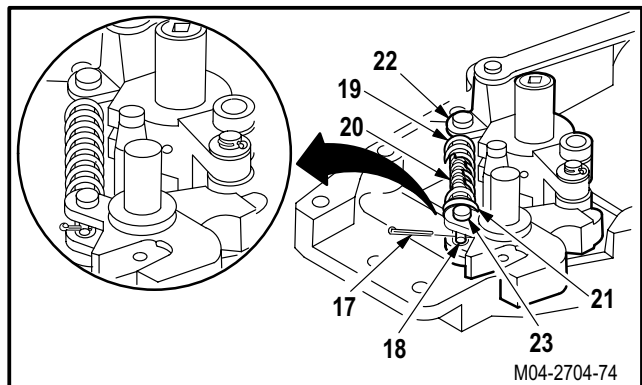

GO TO NEXT PAGE



## 16.5. PYLON RACK DISASSEMBLY/ASSEMBLY (AVIM) - continued

e. Install temporary cotter pin (24) through hole at end of rod (25) to retain springs (26) and (27) and spacer (28) on aft hook assembly (29) during removal.

- (1) Compress springs (26) and (27) until cotter pin hole in rod (25) is visible.
- (2) Insert pin (24) through hole in rod (25).

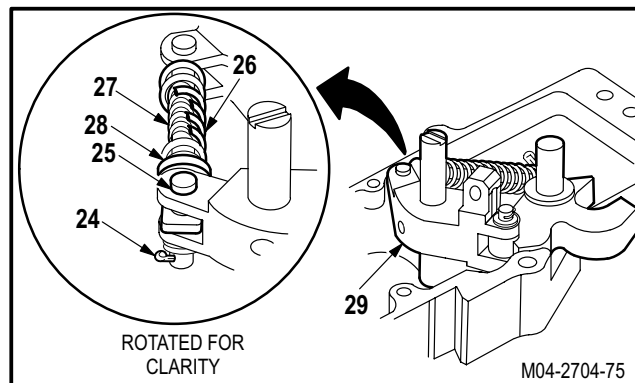

f. Remove forward hook assembly (22), link (30), and Aft hook assembly (29) from mounting bracket (6).

- (1) Grasp Forward hook assembly (22) with left hand and Aft hook assembly (29) with right hand. Slowly work both assemblies loose from mounting bracket (6) with link (30) still attached.

g. Remove link (30) from assemblies (22) and (29).

- (1) Remove and discard two cotter pins (31).
- (2) Remove two washers (32) and two pins (33).

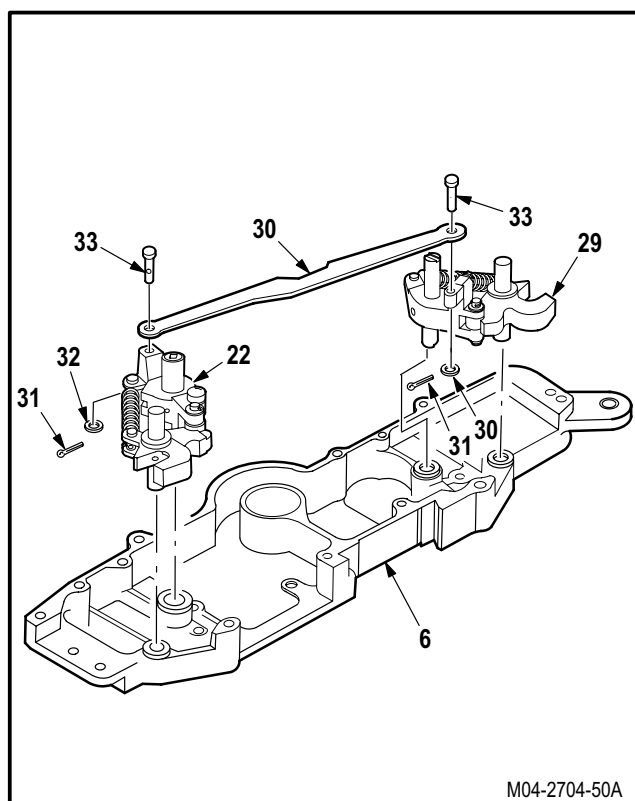

GO TO NEXT PAGE

16.5. PYLON RACK DISASSEMBLY/ASSEMBLY (AVIM) - continued

h. Forward hook disassembly (22).

- (1) Remove and discard cotter pin (34).
- (2) Remove washer (35).
- (3) Remove pin (36) from bellcrank (37).
- (4) Compress springs (19) and (20) and remove cotter pin (17).
- (5) Remove rod (18), springs (19) and (20), and spacer (21).
- (6) Remove pin (38) from hook (39).
- (7) Remove and discard two cotter pins (40).
- (8) Remove two washers (41).
- (9) Remove pin (42) and sleeve bearing (43) from bellcrank (37).
- (10) Remove spring pin (44) from bellcrank (37). Discard spring pin (TM 1-1500-204-23).
- (11) Remove pin (45) from bellcrank (37).
- (12) Remove spring pin (46) from hook (39) and pin (47). Discard spring pin (TM 1-1500-204-23).
- (13) Remove pin (47) from hook (39).

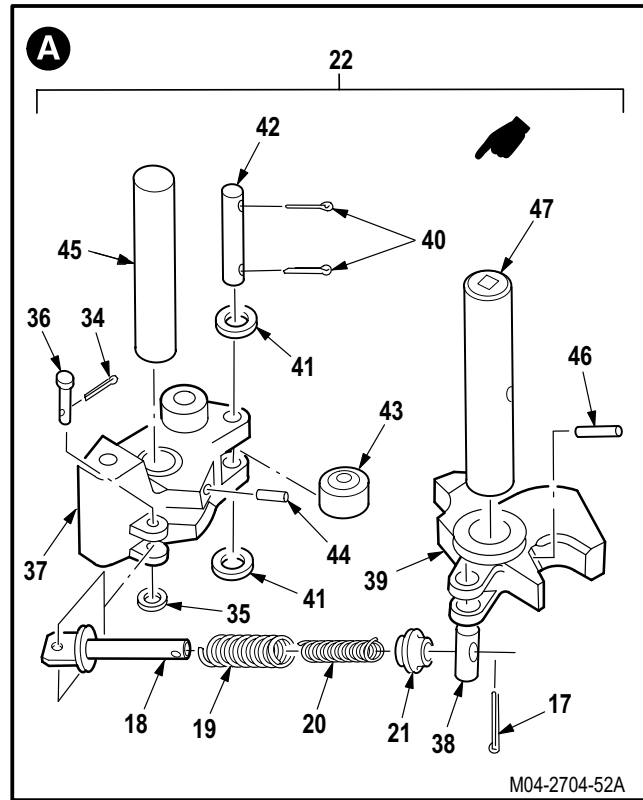

GO TO NEXT PAGE

**16.5. PYLON RACK DISASSEMBLY/ASSEMBLY (AVIM) - continued**

**i. Aft hook disassembly (29).**

- (1) Remove and discard cotter pin (48).
- (2) Remove washer (49).
- (3) Remove pin (50) from bellcrank (51).
- (4) Compress springs (26) and (27) and remove cotter pin (24).
- (5) Remove rod (25), springs (26) and (27), and spacer (28).
- (6) Remove pin (52) from hook (53).
- (7) Remove and discard two cotter pins (54).
- (8) Remove two washers (55).
- (9) Remove pin (56) and sleeve bearing (57) from bellcrank (51).
- (10) Remove spring pin (58) from bellcrank (51). Discard spring pin (TM 1-1500-204-23).
- (11) Remove pin (59) from bellcrank (51).
- (12) Hold eye bolt (60). Remove nut (61) and washer (62).
- (13) Remove bolt (60) and washers (62) from bellcrank (51).
- (14) Remove spring pin (63) from hook (53) and pin (64). Discard spring pin (TM 1-1500-204-23).
- (15) Remove pin (64) from hook (53).

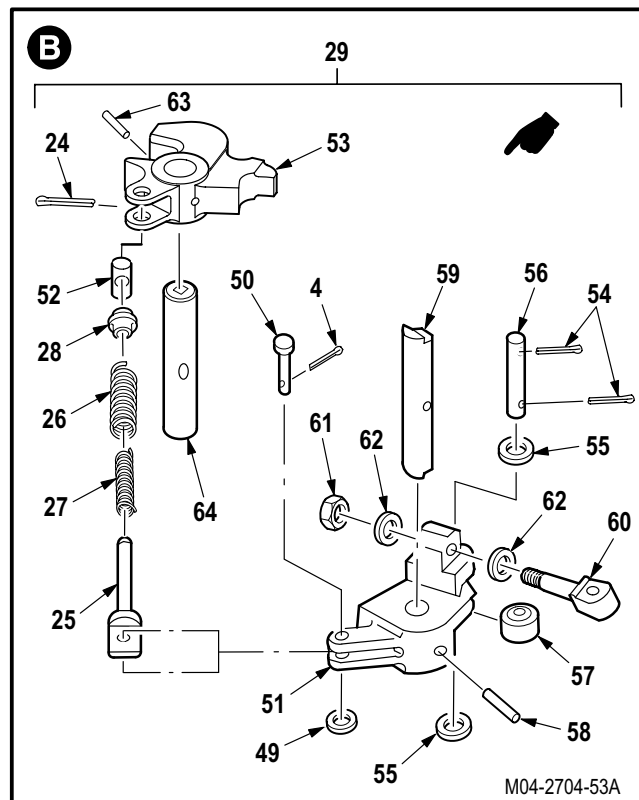

**16.5.4. Cleaning**

- a. Clean pylon rack components** (para 1.47). Use dry cleaning solvent (item 74, App F).

GO TO NEXT PAGE

**16.5. PYLON RACK DISASSEMBLY/ASSEMBLY (AVIM) - continued**

16.5.5. Inspection

- a. **Check pylon rack components for corrosion** (para 1.49).
- b. **Check dowel pins for cracks or distortion.** None allowed.

**NOTE**

Inspection of pylon rack shall be performed internally and externally.

- c. **Check the left and right housing for cracks** (para 16.1). None allowed.
- d. **Inspection area for pylon rack shall be mounting area around pivot point, extending outward four inches onto rack surface** (para 16.1). None allowed.
- e. **Check internal component assemblies for cracks.** None allowed.
- f. **Check forward bellcrank for cracks using magnifier.** None allowed.

16.5.6. Repair

**NOTE**

Replacement of the two dowel pins is typical for forward and aft pins.

- a. **Repair mounting bracket (5) by replacing dowel pins (65).**
  - (1) Position mounting bracket (5) in arbor press (66) with pins (65) inside of mounting bracket facing away from ram (67).
  - (2) Ensure driver (68) and pin (65) are alined. Slowly press pins (65) out of mounting bracket (5).
  - (3) Remove mounting bracket (5) from arbor press (66).

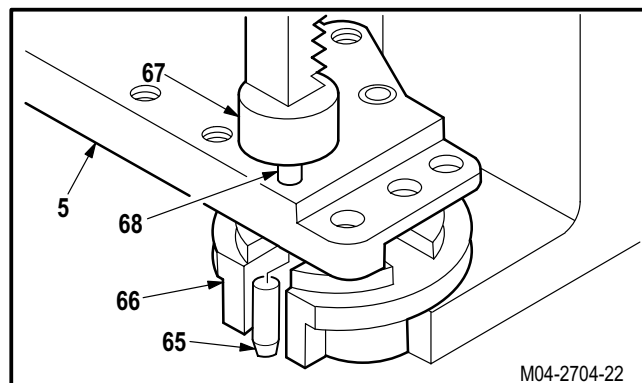
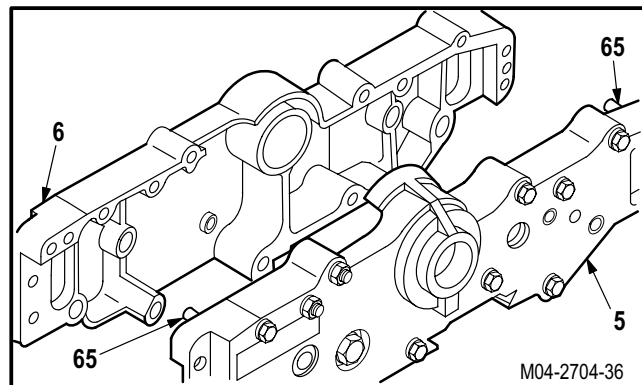

GO TO NEXT PAGE

**16.5. PYLON RACK DISASSEMBLY/ASSEMBLY (AVIM) - continued**

- (5) Ensure driver (68) and new pin (65) are alined. Slowly press dowel pin (65) into mounting bracket (5) until pin (65) is protruding **0.500 INCH** from mounting bracket (5) mating surface.
- (6) Remove mounting bracket (5) from arbor press (66).

16.5.7. Assembly



**NOTE**

Applied primer must be wet when pins are installed.

**a. Aft hook assembly (29).**

- (1) Apply primer to new spring pin (63). Use epoxy primer coating kit (item 78, App F) (TM 55-1500-345-23).
- (2) Insert pin (64) in hook (53).
- (3) Aline hole in pin (64) with hole in hook (53). Install spring pin (63) (TM 1-1500-204-23).

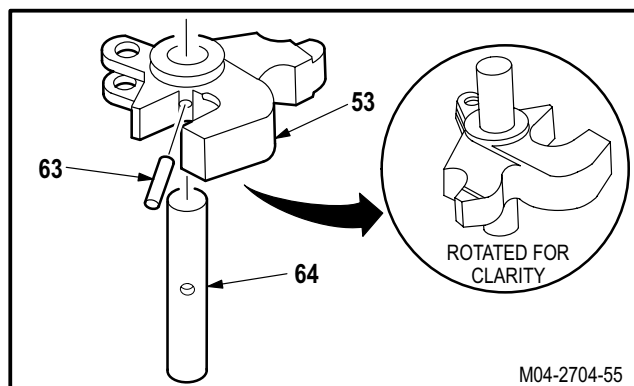
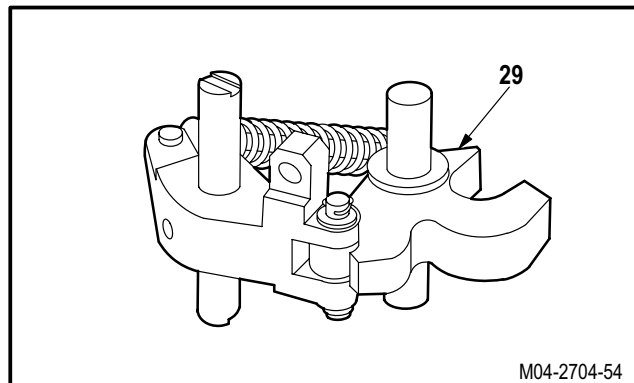

GO TO NEXT PAGE

16.5. PYLON RACK DISASSEMBLY/ASSEMBLY (AVIM) - continued

- (4) Apply primer to new spring pin (58). Use epoxy primer coating kit (item 78, App F) (TM 55-1500-345-23).
- (5) Apply grease sparingly to pin (59). Use grease (item 86, App F).
- (6) Insert pin (59) in bellcrank (51).
- (7) Aline hole in pin (59) with hole in bellcrank (51). Ensure slotted end (69) of pin (59) is alined with mount hole for pin (56). If slotted end (69) does not aline with mount hole in pin (56), reverse pin. Install spring pin (58) (TM 1-1500-204-23).
- (8) Apply grease sparingly to pin (56). Use grease (item 86, App F).
- (9) Place sleeve bearing (57) in clevis of bellcrank (51).
- (10) Insert pin (56) through bellcrank (51) and sleeve bearing (57).
- (11) Install two washers (55).
- (12) Install two new cotter pins (54).
- (13) Apply grease sparingly to pin (52). Use grease (item 86, App F).
- (14) Install pin (52) in hook (53).
- (15) Assemble spring (27), spring (26), and spacer (28) on rod (25).

**NOTE**

Ensure temporary cotter pin is positioned to allow removal after aft hook assembly is installed in rack.

- (16) Insert rod (25) through hole in pin (52). Compress springs (26) and (27) until hole in rod (25) extends beyond pin (52).
- (17) Install cotter pin (24) through hole at end of rod (25) to retain springs (26), (27), and spacer (28).

GO TO NEXT PAGE

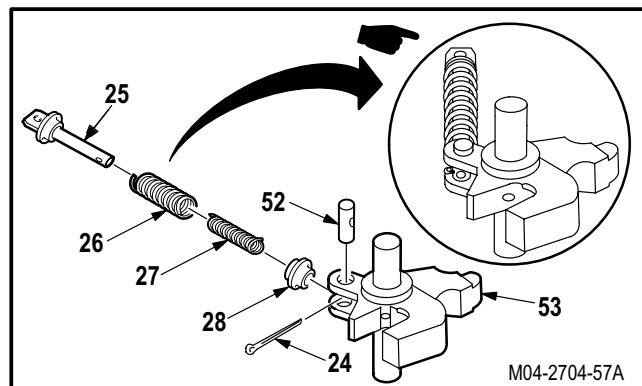
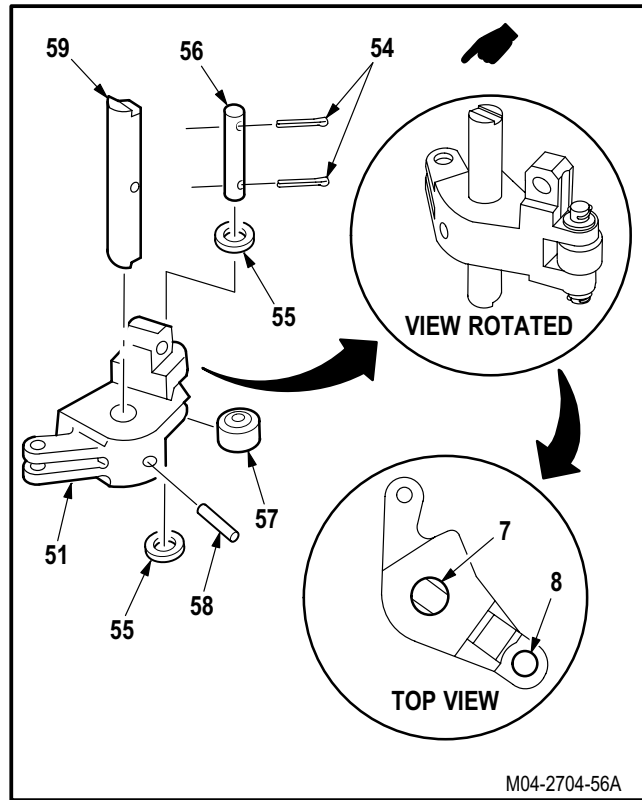

16.5. PYLON RACK DISASSEMBLY/ASSEMBLY (AVIM) - continued



(18) Apply grease sparingly to pin (50). Use grease (item 86, App F).

(19) Aline attachment holes of rod (25) and bell-crank (51). Install pin (50), washer (49), and cotter pin (48).

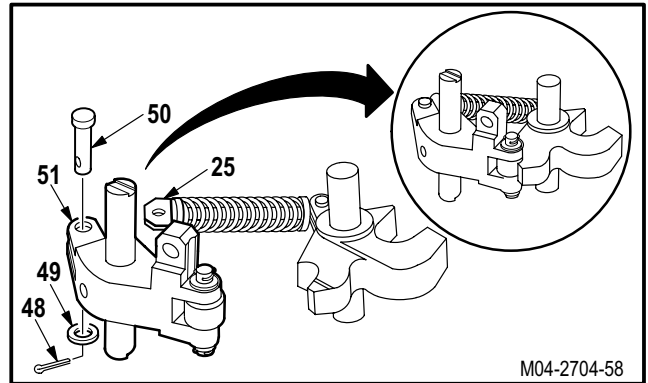

b. Forward hook assembly (22).

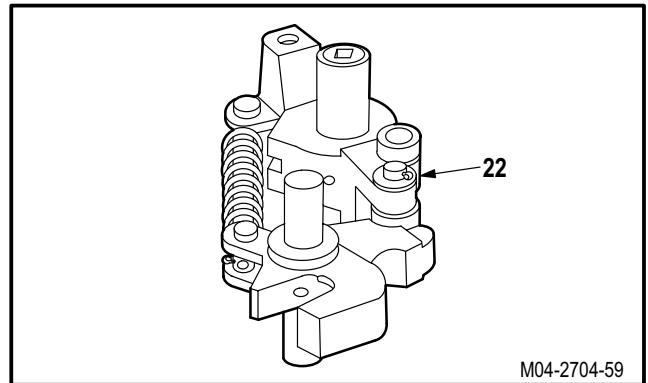

(1) Apply primer to new spring pin (46). Use epoxy primer coating kit (item 78, App F) (TM 55-1500-345-23).

(2) Insert pin (47) in hook (39).

(3) Aline hole in pin (47) with hole in hook (39). Install spring pin (46) (TM 1-1500-204-23).

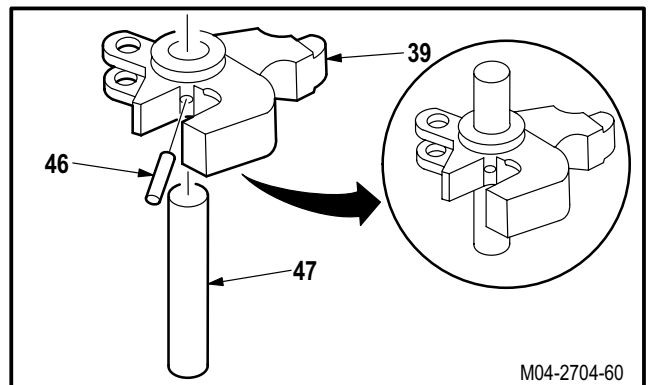

GO TO NEXT PAGE

16.5. PYLON RACK DISASSEMBLY/ASSEMBLY (AVIM) - continued

- (4) Apply primer to new spring pin (44). Use epoxy primer coating kit (item 78, App F) (TM 55-1500-345-23).



- (5) Apply grease sparingly to pin (45). Use grease (item 86, App F).
- (6) Insert pin (45) in bellcrank (37).
- (7) Aline hole in pin (45) with hole in bellcrank (37). Install pin (44) (TM 1-1500-204-23).
- (8) Apply grease sparingly to pin (42). Use grease (item 86, App F).
- (9) Place sleeve bearing (43) in clevis of bellcrank (37).
- (10) Insert pin (42) through bellcrank (37) and sleeve bearing (43).
- (11) Install two washers (41).
- (12) Install two new cotter pins (40).
- (13) Apply grease sparingly to pin (38).
- (14) Install pin (38) in hook (39).
- (15) Assemble spring (20), spring (19), and spacer (21) on rod (18).

**NOTE**

Ensure temporary cotter pin is positioned to allow removal after hook assembly is installed in rack.

- (16) Insert rod (18) through hole in pin (38). Compress springs (19) and (20) until hole in rod (18) extends beyond pin (38).
- (17) Install cotter pin (17) through hole at end of rod (18) to retain springs (19), (20), and spacer (21).

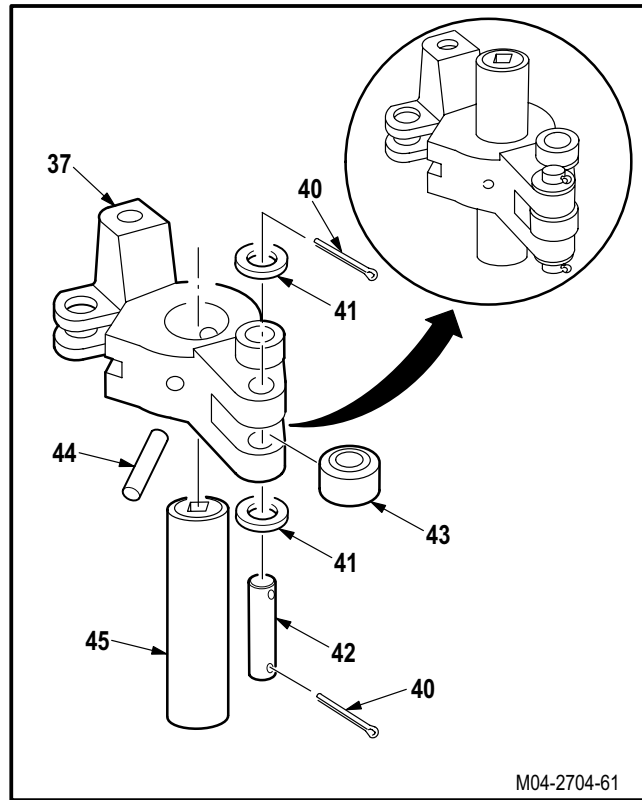

M04-2704-61

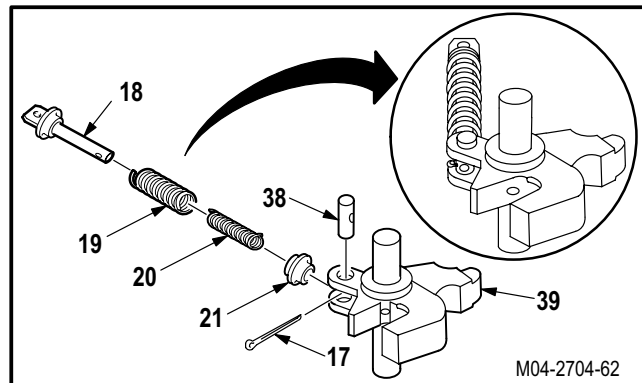

M04-2704-62

GO TO NEXT PAGE



**16.5. PYLON RACK DISASSEMBLY/ASSEMBLY (AVIM) - continued**

- (18) Apply grease sparingly to pin (36). Use grease (item 86, App F).
- (19) Aline attachment holes of rod (18) and bell-crank (37). Install pin (36), washer (35), and cotter pin (34).

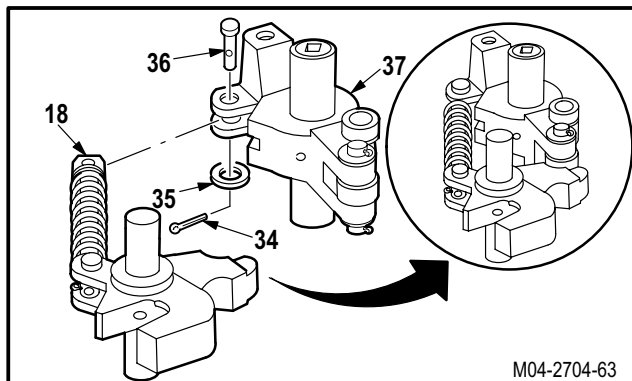

**c. Attach link (30) to forward hook assembly (22).**

- (1) Apply grease sparingly to pin (33). Use grease (item 86, App F).
- (2) Insert pin (33) through link (30) and forward hook assembly (22).
- (3) Install washer (32) and new cotter pin (34).

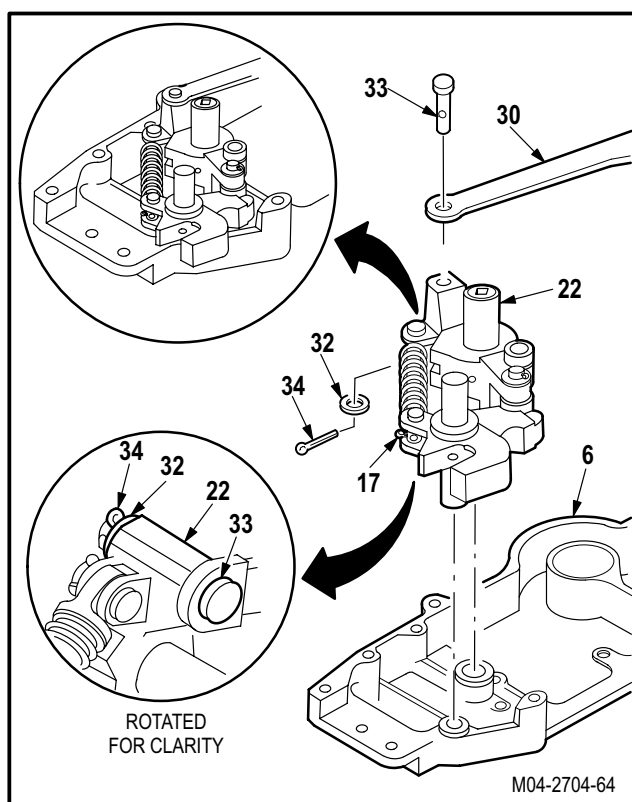

**d. Install forward hook assembly (22) in mounting bracket (6) with link (30) attached.**

- (1) Apply grease sparingly to mounting bracket (6) and forward hook assembly (22) attach point. Use grease (item 86, App F).
- (2) Install forward hook assembly (22) in mounting bracket (6).
- (3) Remove pin (17).

**e. Install aft hook assembly (29) in mounting bracket (6).**

- (1) Apply grease sparingly to mounting bracket (6) and aft hook assembly (29) attach points. Use grease (item 86, App F).
- (2) Install aft hook assembly (29) in mounting bracket (6).
- (3) Remove pin (17).

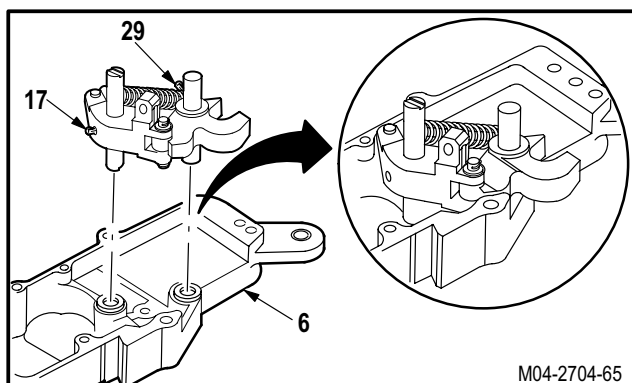

GO TO NEXT PAGE

16.5. PYLON RACK DISASSEMBLY/ASSEMBLY (AVIM) - continued

f. Attach link (30) to aft hook assembly (29).

- (1) Apply grease sparingly to pin (33). Use grease (item 86, App F).
- (2) Insert pin (33) through link (30) and eye bolt (60) of aft hook assembly (29).
- (3) Install washer (32) and new cotter pin (31).
- (4) Insert bolt (60) in aft hook assembly (29).

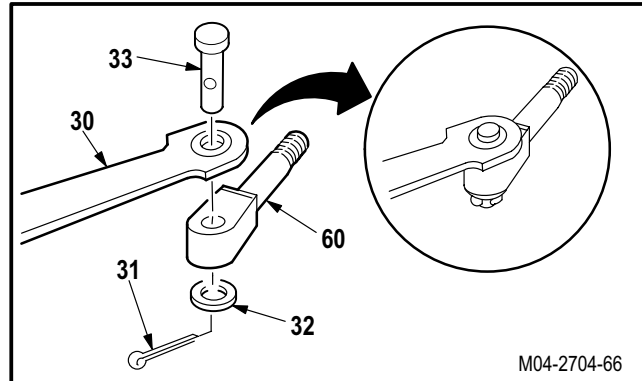

**NOTE**

Ensure both hooks are in LOCK position.

g. While applying pressure with finger to stud end of bolt (60), measure distance between shoulder of bolt (60) and attach point on aft hook assembly (29).

- (1) If distance is less than **0.005 INCH**, install washer (62) and nut (61) then go to step i.
- (2) If distance is greater than **0.005 INCH**, go to step h.

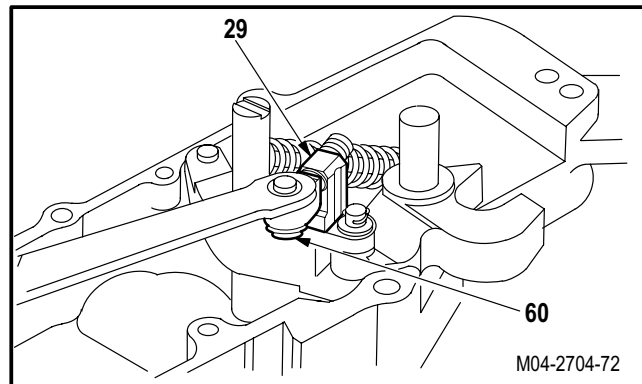

h. Adjust distance between back of bolt (60) and attach point on aft hook assembly (29).

- (1) Remove bolt (60) from attach point on aft hook assembly (29).
- (2) Add washers (62) as required until distance is less than **0.005 INCH** between shoulder of bolt (60) and attach point on aft hook assembly (29).
- (3) Insert bolt (60) through aft hook assembly (29).
- (4) Install washer (62) and nut (61).

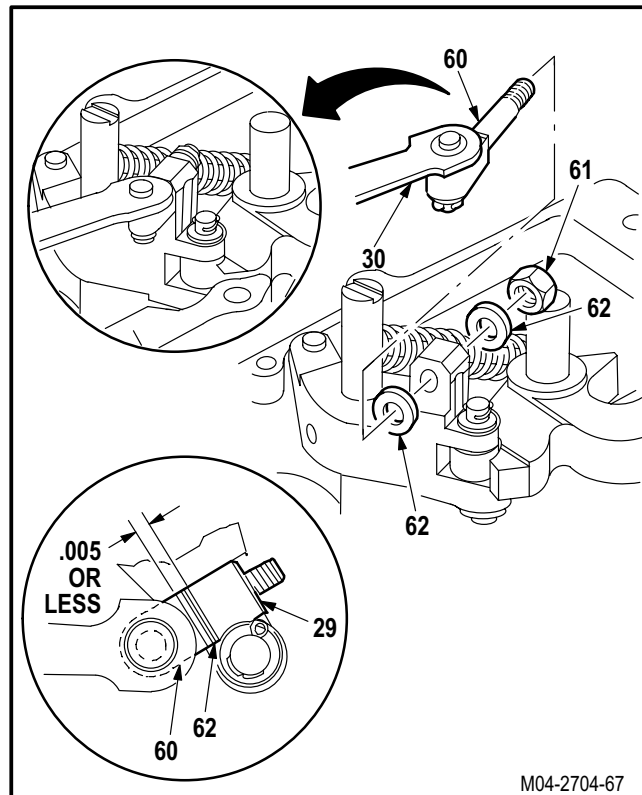

GO TO NEXT PAGE

**16.5. PYLON RACK DISASSEMBLY/ASSEMBLY (AVIM) - continued**

i. **Install two bumpers (16) in mounting bracket (6).**

j. **Join mounting brackets (5) and (6) of rack (4).**

- (1) Apply grease sparingly to attach points on assemblies (22) and (29), and mounting bracket (5). Use grease (item 86, App F).
- (2) Aline dowel pins (65), bumpers (16) and assemblies (22) and (29) with mounting bracket (5) attach points.
- (3) Press two mounting bracket halves (5) and (6) together. Tap gently until seated.

**NOTE**

- Unless otherwise stated all bolt installations in the following steps will be installed from the left half of pylon rack.
- Applied primer must be wet when bolts are installed.

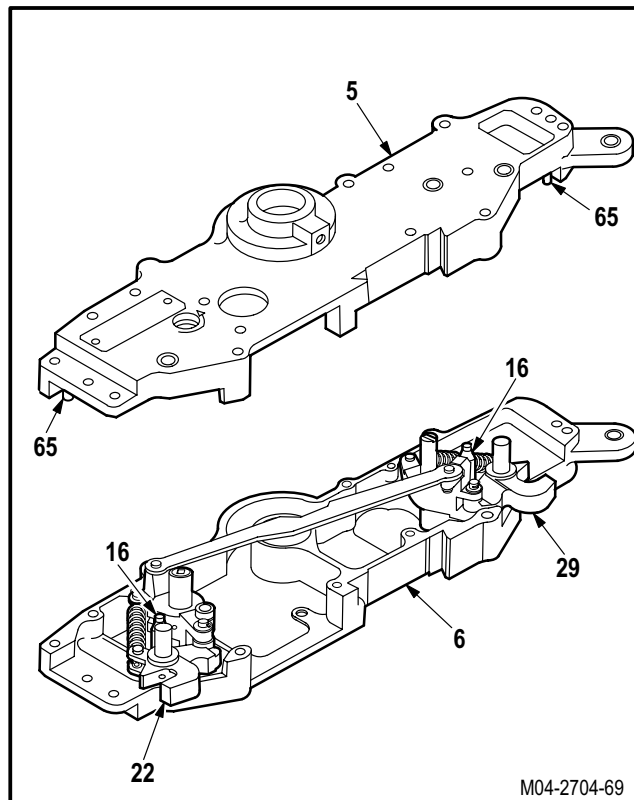

k. **Secure mounting bracket halves (5) and (6) of rack (4).**



- (1) Apply primer to bolts (9) and (11). Use epoxy primer coating kit (item 78, App F) (TM 55-1500-345-23).
- (2) Install six bolts (9) with washers (8) through rack (4).
- (3) Install six washers (8) and nuts (7) on bolts (9).
- (4) Install bolt (11) (with safety wire holes) with washer (10) through rack (4).
- (5) Install washer (10) and nut (7) on bolt (11).

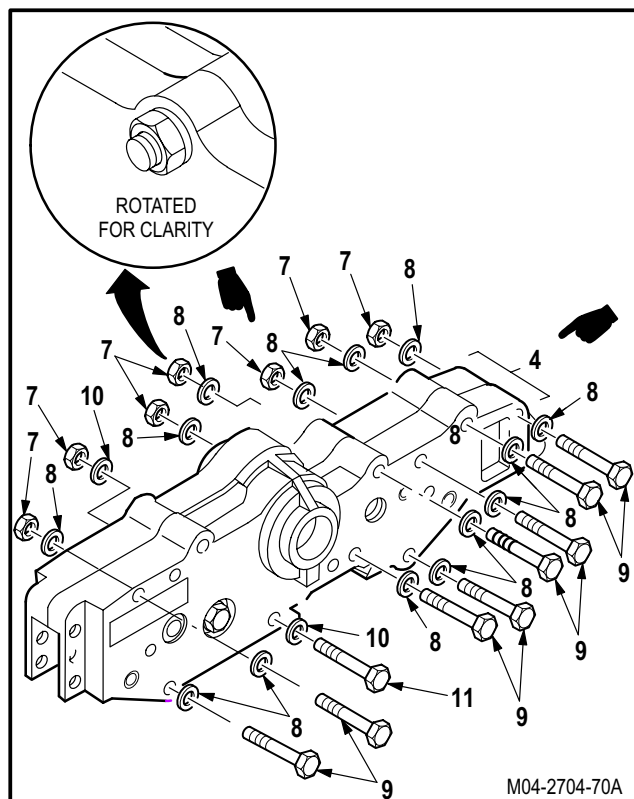

GO TO NEXT PAGE

**16.5. PYLON RACK DISASSEMBLY/ASSEMBLY (AVIM) - continued**

- (6) Apply primer to bolt (15). Use epoxy primer coating kit (item 78, App F) (TM 55-1500-345-23).
- (7) Install bolt (15) with washer (14) through rack (4).
- (8) Install washer (14) and nut (13) on bolt (15).
- (9) Install bolt (9) with washer (8) from right half (6) of rack (4).
- (10) Install washer (8) and nut (7) on bolt (9).
- (11) Install bolt (9) with washer (8) from right half (6) of rack (4).
- (12) Install electrical leads, (73) washer (8) and nut (7) on bolt (9).

**l. Install HOOK LOCKED/HOOK UNLOCKED indicator (two places).**

- (1) Insert screw (2) through washer (3) and indicator (1) in rack (4).

m. **Install two sway braces on rack** (para 16.21).

n. **Install pylon stow bracket on rack** (para 16.17).

**o. Check rack hooks (39) and (53) for allowable release torque.**

- (1) Position rack hooks (39) and (53) to HOOK-LOCKED position (70).
- (2) Position torque wrench in MANUAL RELEASE fitting (71) and move hooks (39) and (53) to HOOK-UNLOCKED position (72). Note torque reading at release point. Use torque wrench.
- (3) Rack is operational if torque reading is equal to or less than **120 INCH-POUNDS**. Replace rack if torque reading is greater than **120 INCH-POUNDS**.

p. **Lubricate all exposed areas of the manual release fitting (71) and hooks (39) and (53) mechanism.** Use corrosion preventive compound (item 63, App F).

q. **Inspect (QA).**

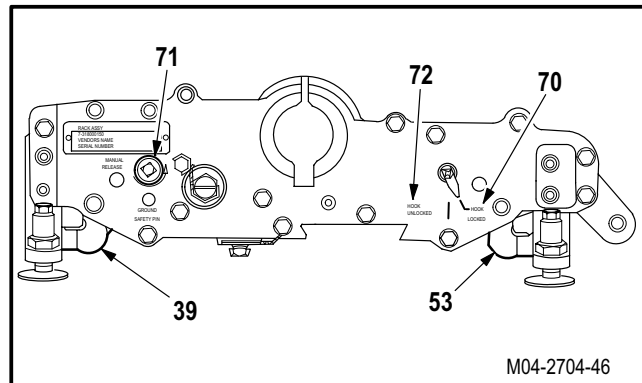
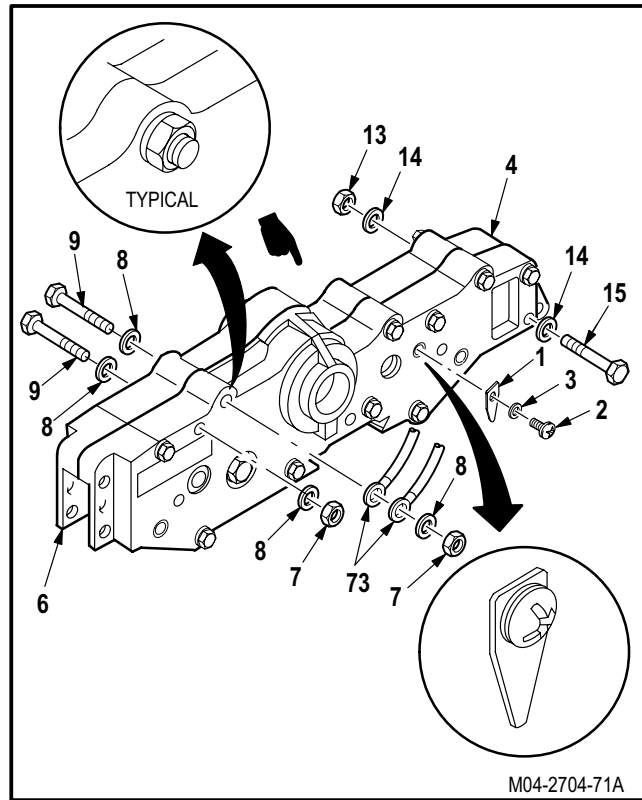

END OF TASK

**16.6. PYLON RACK EJECTOR REMOVAL/INSTALLATION**

16.6.1. Description

This task covers: Removal. Cleaning. Inspection. Installation.

16.6.2. Initial Setup

**Tools:**

- Electrical tool kit (item 378, App H)
- Light duty laboratory apron (item 27, App H)
- Chemical protective gloves (item 154, App H)
- 5X & 12X monocular magnifier (item 206, App H)
- Adjustable air filtering respirator (item 262, App H)

**Personnel Required:**

- 68X Armament/Electrical System Repairer
- 68X3F Armament/Electrical System Repairer/  
Technical Inspector

**References:**

- TM 1-1520-238-T
- TM 1-1520-264-23
- TM 55-1500-323-24

**Materials/Parts:**

- Adhesive (item 16, App F)
- Strap (item 193, App F)
- Wire (item 230, App F)

**Equipment Conditions:**

<u>Ref</u>	<u>Condition</u>
16.4	Pylon rack removed

16.6.3. Removal

a. **Remove ejector (1) from rack (2).**

- (1) Remove lockwire from piston retainer (3) and bolt (4) on rack (2).
- (2) Hold three bolts (5). Remove three nuts (6) and washers (7).
- (3) Remove three bolts (5) and three washers (7) from rack (2) and ejector (1).
- (4) Remove three bushings (8) from rack (2).

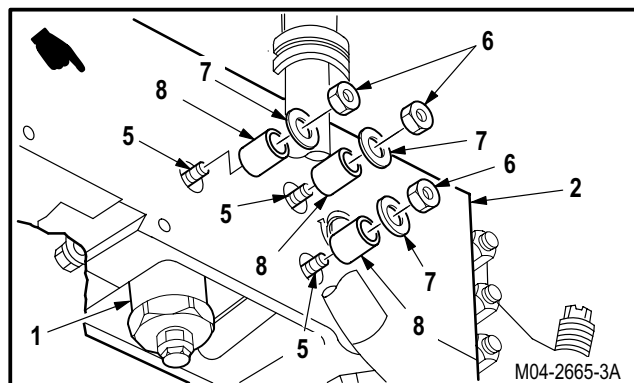
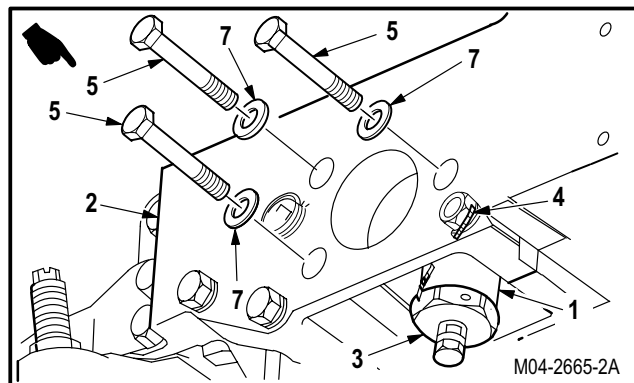

GO TO NEXT PAGE

16.6. PYLON RACK EJECTOR REMOVAL/INSTALLATION - continued

**NOTE**

Pylon hooks must be locked to remove ejector.

- (5) Slide ejector (1) down until ground wires (9) and contact wires (10) can be detached.
- (6) Remove screw (11) and washer (12) that attach ground wires (9) and electrical lead (21) to boss (13).
- (7) Remove two screws (14) from retainer (15). Remove contact (16) and insulator (17).
- (8) Remove and discard two tie straps (18) from ejector (1).
- (9) Remove jettison wire (605) harness (20) from rack (2).
- (10) Slide ejector (1) from bottom of rack (2).

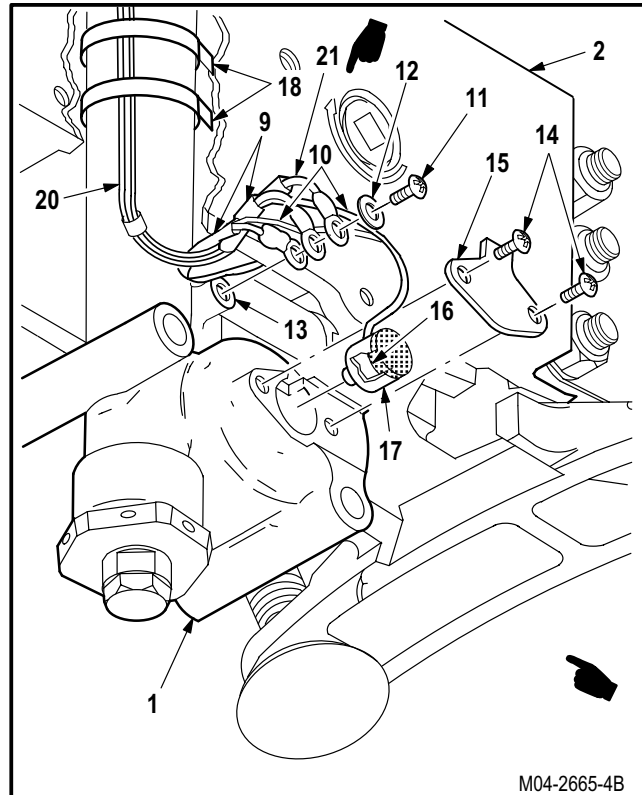

16.6.4. Cleaning

- a. **Wipe ejector and mounting surfaces of rack with a clean rag.**
- b. **Remove adhesive from contact and insulator (para 1.47).**

16.6.5. Inspection

- a. **Check rack for cracks ( TM 1-1520-264-23).**
- b. **Check ejector for cracks using a magnifier (para 16.1).**
- c. **Check contact and insulator for damage. None allowed.**

16.6.6. Installation

- a. **Install contact (16) in insulator (17) until fully seated.**



- b. **Fill insulator (17) with adhesive (TM 55-1500-323-24). Use adhesive (item 16, App F).**

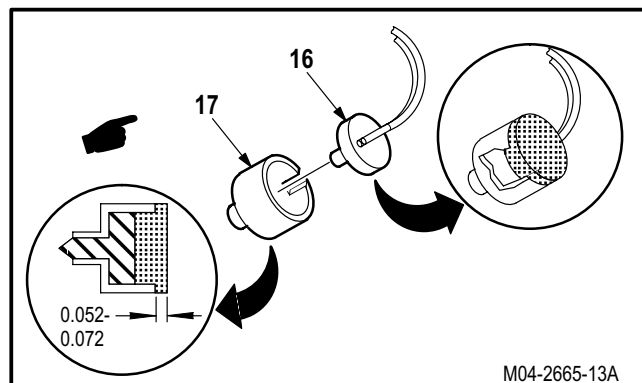

GO TO NEXT PAGE

16.6. PYLON RACK EJECTOR REMOVAL/INSTALLATION - continued

**NOTE**

- (1) Adhesive should protrude **0.052 to 0.072 INCH** from insulator.

**c. Install ejector (1) into rack (2).**

- (1) Slide ejector (1) part way into rack (2) until wires (9) and wires (10) can be attached.
- (2) Place insulator (17) and contact (16) in receptacle (19).
- (3) Install retainer (15) on receptacle (19) using two screws (14).
- (4) Install screw (11) through washer (12) and two wires (9) into boss (13).
- (5) Install two tie straps (18) on ejector (1). Use strap (item 193, App F).
- (6) Aline bolt holes in ejector (1) and rack (2).

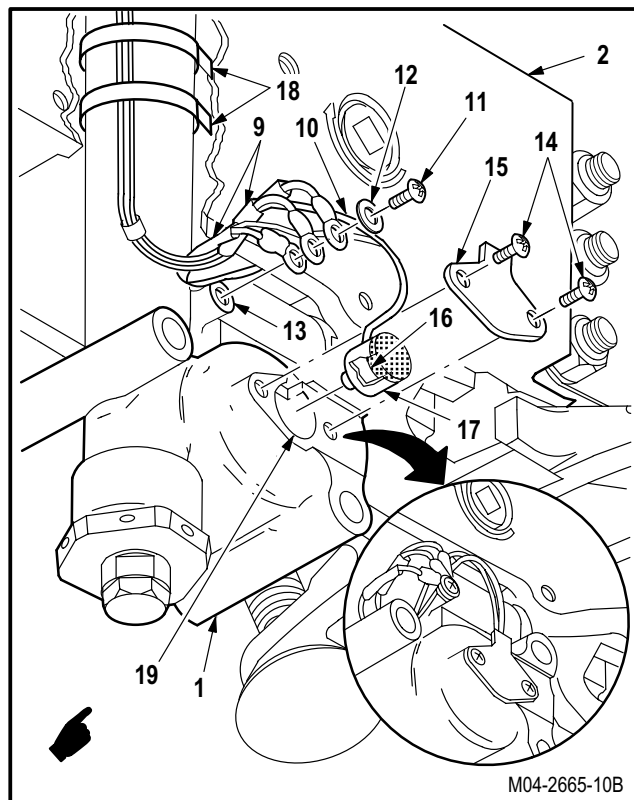

- (7) Install three bushings (8) in holes on rack (2).
- (8) Install three bolts (5) with washers (7) through alined holes.
- (9) Hold three bolts (5). Install three washers (7) and nuts (6).
- (10) Lockwire retainer (3) to bolt (4). Use wire (item 230, App F).

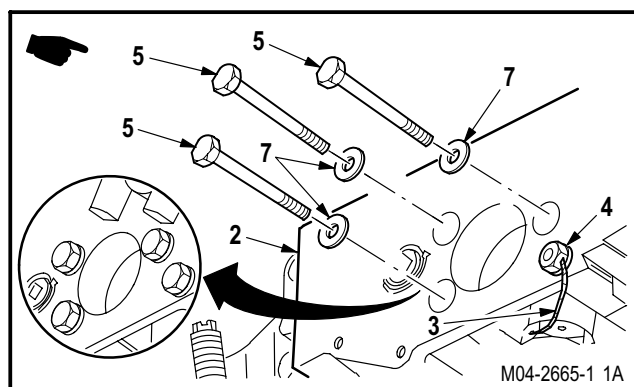

**d. Inspect (QA).**

**e. Install pylon rack (para 16.4).**

**f. Perform external stores jettison maintenance operational check (TM 1-1520-238-T).**

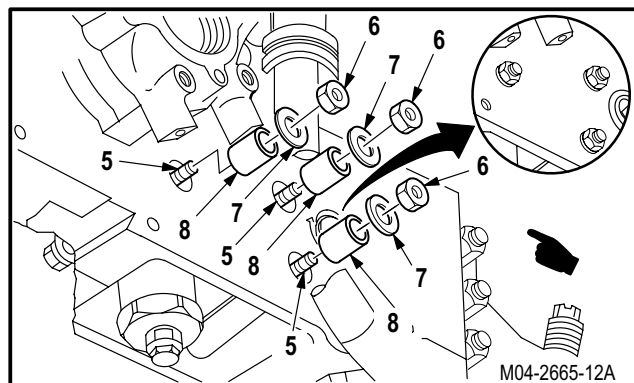

END OF TASK

**16.7. PYLON RACK EJECTOR DISASSEMBLY/ASSEMBLY**

<sup>3</sup>  
16.7.1. Description

This task covers: Disassembly. Cleaning. Inspection. Assembly.

16.7.2. Initial Setup

**Tools:**

- Electrical tool kit (item 378, App H)
- 3/4 x 3/8-inch drive torque wrench adapter (item 20, App H)
- Light duty laboratory apron (item 27, App H)
- 3/16 - 5/8-inch hexagon x 1/2-inch drive screwdriver bit set (item 37, App H)
- Chemical protective gloves (item 154, App H)
- Adjustable air filtering respirator (item 262, App H)
- 1 5/16 x 3/4-inch drive socket wrench socket (item 314, App H)
- 1 1/4 & 1 5/16-inch open end wrench (item 419, App H)
- 0 - 300 inch-pound 3/8-inch drive click type torque wrench (item 439, App H)
- 5X & 12X monocular magnifier (item 206, App H)

**Personnel Required:**

- 68X Armament/Electrical System Repairer
- 68X3F Armament/Electrical System Repairer/  
Technical Inspector

**References:**

- TM 1-1520-264-23
- TM 55-1500-344-23

**Materials/Parts:**

- Packing (5)
- Ring Piston
- Brush (item 37, App F)
- Brush (item 38, App F)
- Cloth (item 52, App F)
- Damping fluid (item 69, App F)
- Dry cleaning solvent (item 74, App F)
- Wire (item 230, App F)

**Equipment Conditions:**

<u>Ref</u>	<u>Condition</u>
1.57	Helicopter safed
16.6	Pylon rack ejector removed

GO TO NEXT PAGE



**16.7. PYLON RACK EJECTOR DISASSEMBLY/ASSEMBLY - continued**

16.7.3. Disassembly

**a. Remove plug (1) from ejector (2).**

- (1) Remove lockwire from plug (1).
- (2) Remove plug (1) from ejector (2).
- (3) Remove and discard packing (3).

**b. Remove orifice (4) from ejector (2).**

- (1) Remove and discard packing (5).

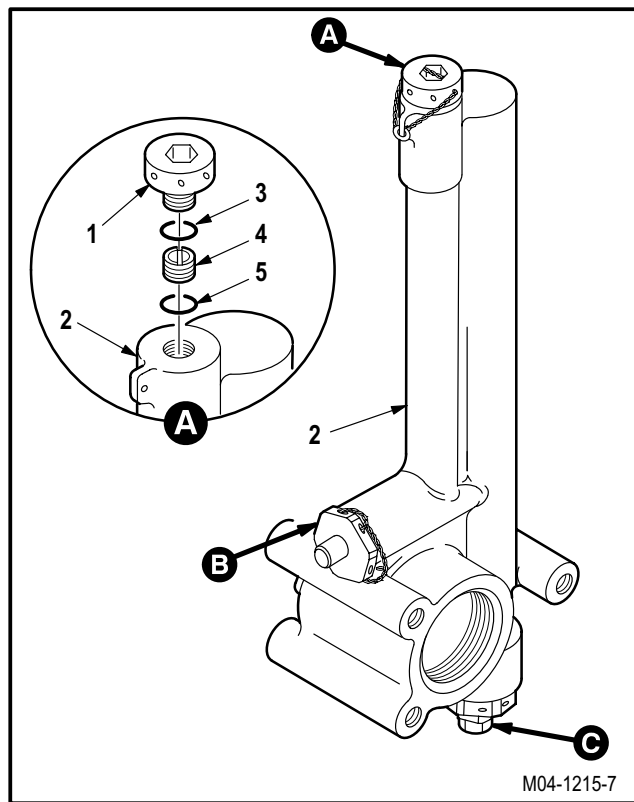

**c. Remove plunger retainer (6) and detent ring (7) from ejector (2).**

- (1) Remove lockwire from retainer (6).
- (2) Remove retainer (6) from ejector (2).
- (3) Remove detent ring (7) from retainer (6).

**d. Remove plunger (8) from ejector (2).**

- (1) Remove and discard packing (9).

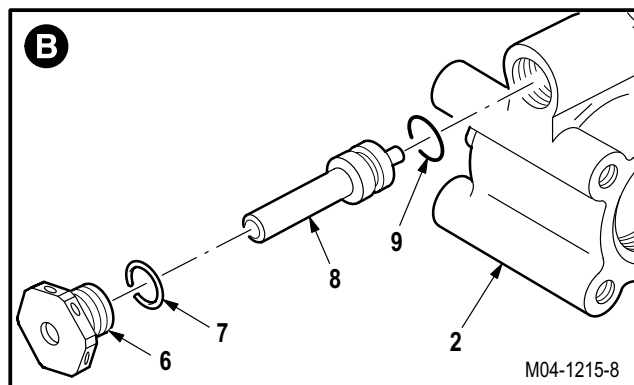

**e. Remove bolt (10) from ejector piston (11).**

- (1) Hold open end wrench on flats of piston (11).
- (2) Remove bolt (10) from piston (11).

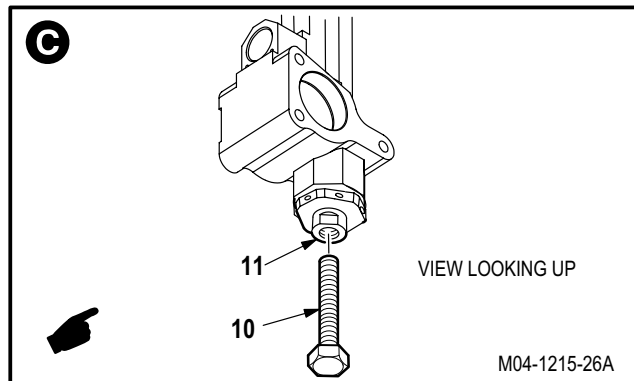

GO TO NEXT PAGE

16.7. PYLON RACK EJECTOR DISASSEMBLY/ASSEMBLY - continued

f. Remove retainer (12) and piston (11) from ejector (2).

- (1) Remove lockwire from retainer (12).
- (2) Remove retainer (12). Use torque wrench, torque wrench adapter, and socket.
- (3) Remove and discard packing (13).

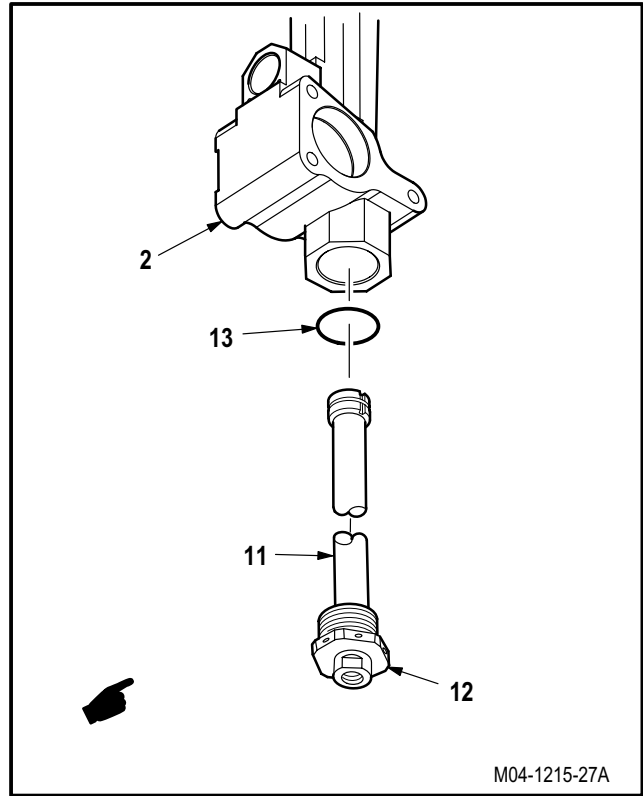

g. Remove ejector piston (11) from retainer (12).

- (1) Remove and discard packing (14).
- (2) Remove and discard piston ring (15).
- (3) Remove and discard packing (16).

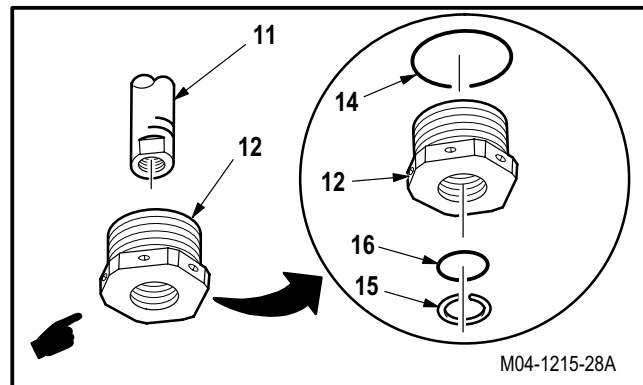

16.7.4. Cleaning



**NOTE**

When pylon stores are jettisoned, clean and inspect jettison rack.

- a. **Clean ejector piston, orifice, and plunger.** Use dry cleaning solvent (item 74, App F) and cloth (item 52, App F) (TM 55-1500-344-23).

GO TO NEXT PAGE

---

**16.7. PYLON RACK EJECTOR DISASSEMBLY/ASSEMBLY - continued**

---

**b. Clean ejector housing.**

- (1) Clean small bore hole in ejector housing. Use brush (item 37, App F) and dry cleaning solvent (item 74, App F).
- (2) Clean large bore hole in ejector housing. Use brush (item 38, App F) and dry cleaning solvent (item 74, App F).
- (3) Clean cartridge bore hole in ejector housing. Use dry cleaning solvent (item 74, App F) and cloth (item 52, App F).

16.7.5. Inspection

- a. **Check ejector housing for cracks. Use magnifier.** None allowed.
- b. **Check, piston, plunger, and retainers for cracks and distortion.** None allowed.
- c. **Check piston, ejector, plunger, and retainers for corrosion** (para 1.49).

16.7.6. Assembly**a. Assemble retainer (12).**

- (1) Lubricate new packings (14) and (16). Use damping fluid (item 69, App F).
- (2) Install packings (14) and (16) on retainer (12).
- (3) Install new piston ring (15) in retainer (12).

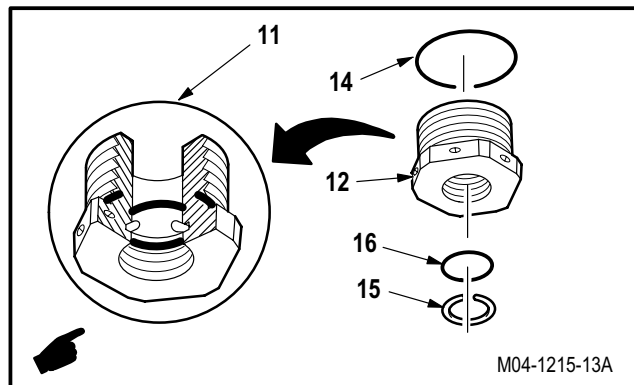

GO TO NEXT PAGE

**16.7. PYLON RACK EJECTOR DISASSEMBLY/ASSEMBLY - continued**

**b. Install piston (11) in retainer (12).**

- (1) Lubricate new packing (13). Use damping fluid (item 69, App F).
- (2) Install packing (13) on piston (11).
- (3) Insert piston (11) in retainer (12).

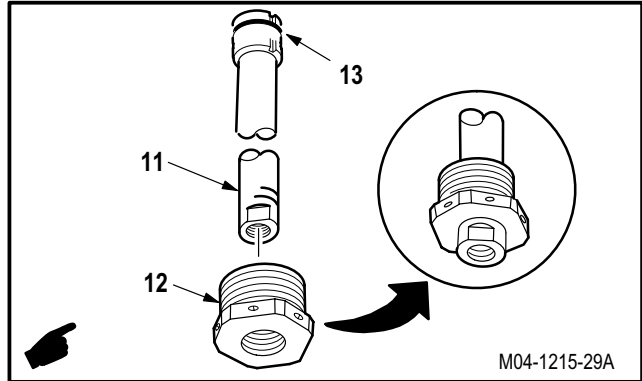

**c. Install retainer (12) and piston (11) in housing (17). Torque retainer (12) to 230 INCH-POUNDS.**

- (1) Install piston (11) with retainer (12) in housing (17).
- (2) Torque retainer (12) to **230 INCH-POUNDS**. Use torque wrench, torque wrench adapter, and socket.
- (3) Lockwire retainer (12) to ejector (2). Use wire (item 230, App F).

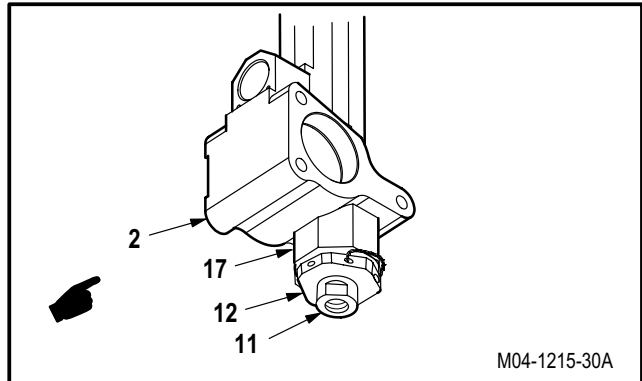

**d. Install bolt (10) in ejector piston (11).**

- (1) Hold open end wrench on flat of piston (11). Install bolt (10) in piston (11).

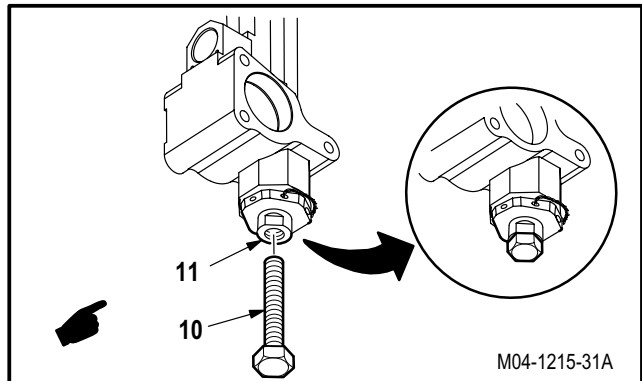

**e. Install plunger (8) in plunger port (18).**

- (1) Lubricate new packing (9). Use damping fluid (item 69, App F).
- (2) Install packing (9) on plunger (8).
- (3) Install plunger (8) in port (18).

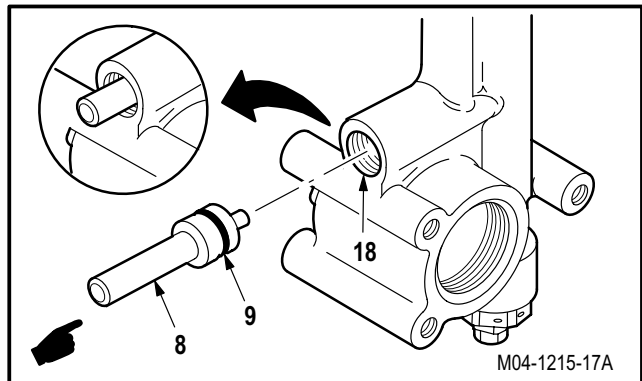

GO TO NEXT PAGE

**16.7. PYLON RACK EJECTOR DISASSEMBLY/ASSEMBLY - continued**

f. **Install plunger retainer (6) in port (18).** Torque retainer (6) to **180 INCH-POUNDS**.

- (1) Install ring (7) on retainer (6).
- (2) Install retainer (6) in port (18).
- (3) Torque retainer (6) to **180 INCH-POUNDS**. Use torque wrench.
- (4) Lockwire retainer (6) to ejector (2). Use wire (item 230, App F).

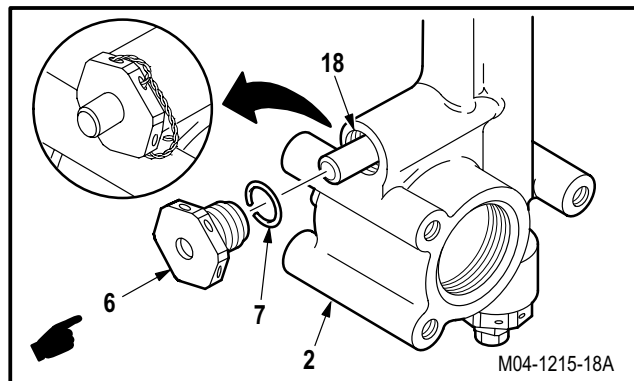

g. **Install new packing (5) in bore (19).**

- (1) Lubricate packing (5). Use damping fluid (item 69, App F).

h. **Install orifice (4) in bore (19).**

- (1) Tighten orifice (4) until threads bottom out.

i. **Install plug (1) in bore (19).** Torque plug (1) to **125 INCH-POUNDS**.

- (1) Lubricate new packing (3). Use damping fluid (item 69, App F).
- (2) Install new packing (3) in groove of plug (1).
- (3) Install plug (1) in bore (19).
- (4) Torque plug (1) to **125 INCH-POUNDS**. Use torque wrench and screwdriver bit set.
- (5) Lockwire plug (1) to housing (2). Use wire (item 230, App F).

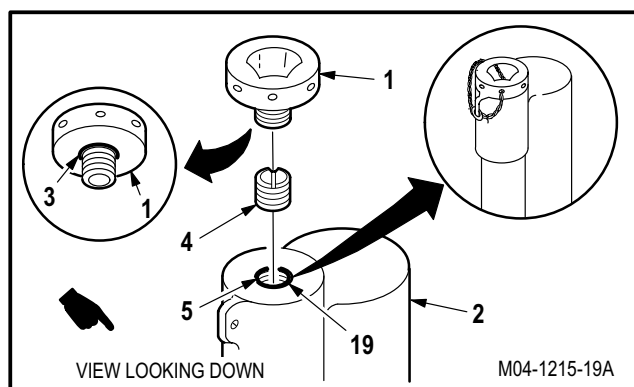

j. **Inspect (QA).**

END OF TASK

**16.8. PYLON RACK EJECTOR TEST SET INSTALLATION/REMOVAL**

16.8.1. Description

This task covers: Calibration. Installation. Removal.

16.8.2. Initial Setup

**Tools:**

Electrical tool kit (item 378, App H)  
 Pylon ejector test set (item 356, App H)

**References:**

TM 1-1520-238-T

**Equipment Conditions:**

<u>Ref</u>	<u>Condition</u>
1.57	Helicopter safed
16.3	Pylon rack ejector impulse cartridge removed

**Personnel Required:**

68X Armament/Electrical System Repairer

16.8.3. Calibration

**a. Prepare pylon ejector test set for use.**

- (1) Detach two covers (1) one from each end of case (2).
- (2) Remove tester (3) and calibration block (4).

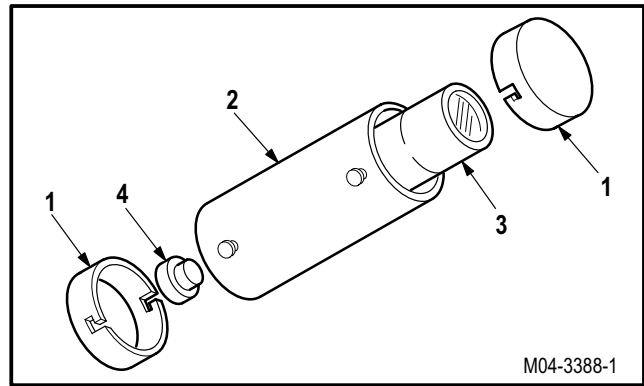

**b. Calibrate tester (3).**

- (1) Press plunger tip (5) firmly against ZERO SET side of block (4).
- (2) Unscrew retaining ring (6) and remove lens (7) if pointer (8) does not read zero. Turn pointer (8) counterclockwise to zero while pressing plunger tip (5) against ZERO SET side of block (4). Install lens (7) and retaining ring (6).
- (3) Firmly press tip (5) against calibration block (4), using 0.050 CHECK side of block (4). Ensure pointer (8) reads between 0.048 and 0.052.
- (4) Return block (4) to case (2).

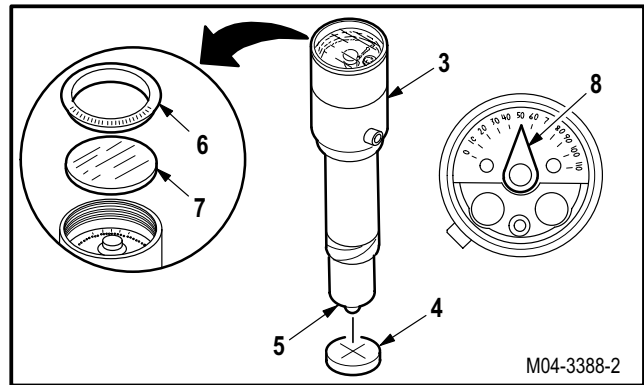

GO TO NEXT PAGE

**16.8. PYLON RACK EJECTOR TEST SET INSTALLATION/REMOVAL - continued**

16.8.4. Installation

- a. **Install calibrated tester (3) into ejector cartridge housing (9).**

**NOTE**

Ensure tester is firmly seated in ejector cartridge housing.

- b. **Perform external stores jettison maintenance operational check (TM 1-1520-238-T).**

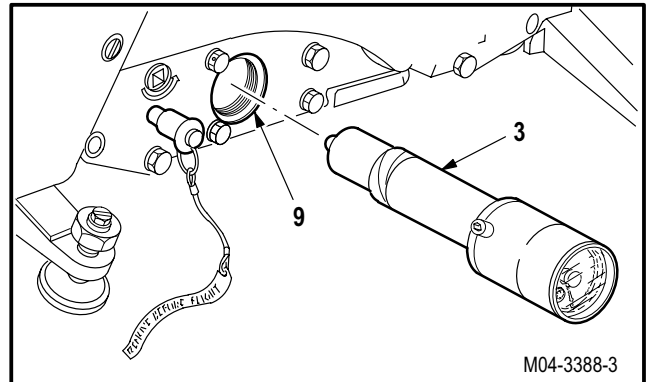

16.8.5. Removal

- a. **Remove tester (3) from housing (9).**
- b. **Return tester (3) to case (2).**
- c. **Attach two covers (1) on case (2).**
- d. **Install pylon rack ejector impulse cartridge (para 16.3).**

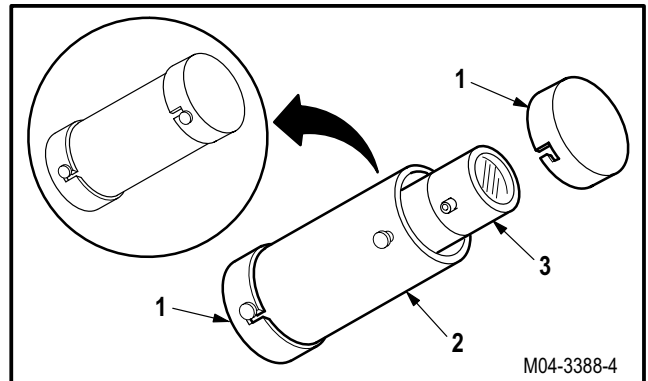

END OF TASK

## 16.9. PYLON ACTUATOR AND TOP PLATE REMOVAL/INSTALLATION

### 16.9.1. Description

This task covers: Removal. Cleaning. Inspection. Installation.

### 16.9.2. Initial Setup

#### Tools:

- Electrical tool kit (item 378, App H)
- 0 - 600 inch-pound 3/8-inch drive dial indicator torque wrench (item 447, App H)
- 5X & 12X monocular magnifier (item 206, App H)

#### References:

- TM 1-1520-264-23

#### Materials/Parts:

- Cotter Pin

#### Personnel Required:

- 68X Armament/Electrical System Repairer
- 68X3F Armament/Electrical System Repairer/  
Technical Inspector

#### Equipment Conditions:

- | <u>Ref</u> | <u>Condition</u>                      |
|------------|---------------------------------------|
| 2.2        | Pylon fairings P1, P2, and P3 removed |
| 16.2       | Pylon removed                         |

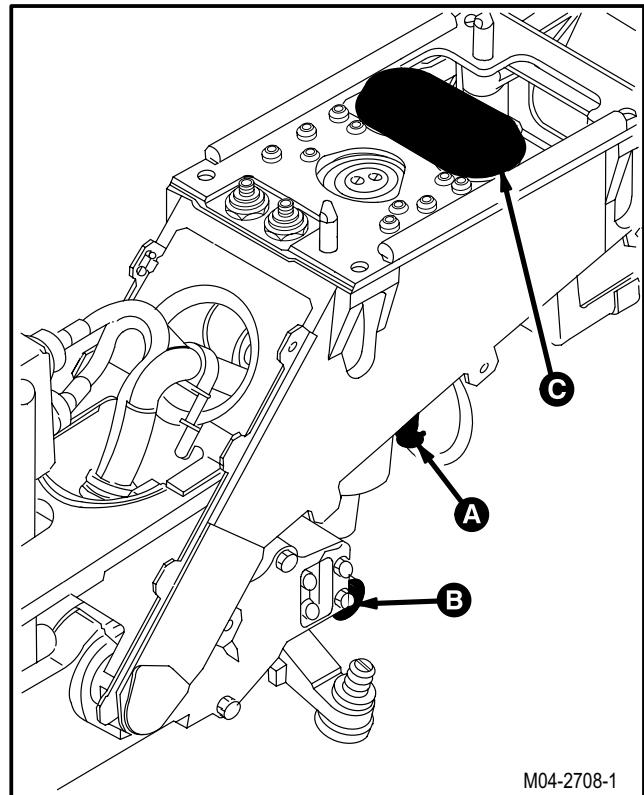

GO TO NEXT PAGE



**16.9. PYLON ACTUATOR AND TOP PLATE REMOVAL/INSTALLATION - continued**

16.9.3. Removal

a. **Detach connector P507 (1) from receptacle J507 (2).**

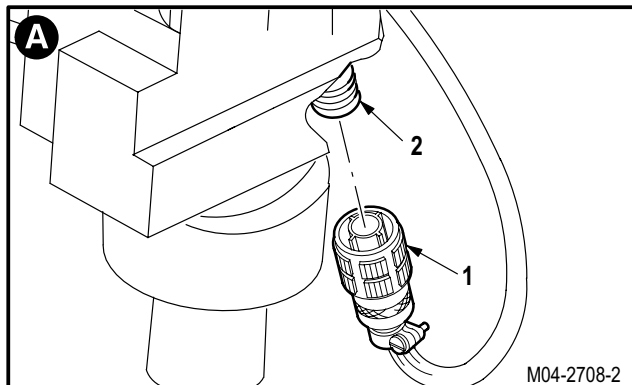

b. **Remove pylon actuator rod end (3) from yoke (4).**

- (1) Remove and discard cotter pin (5) from bolt (6).
- (2) Hold bolt (6). Remove nut (7) and washer (8).
- (3) Remove bolt (6) from yoke (4) and rod end (3).
- (4) Remove rod end (3) from yoke (4).

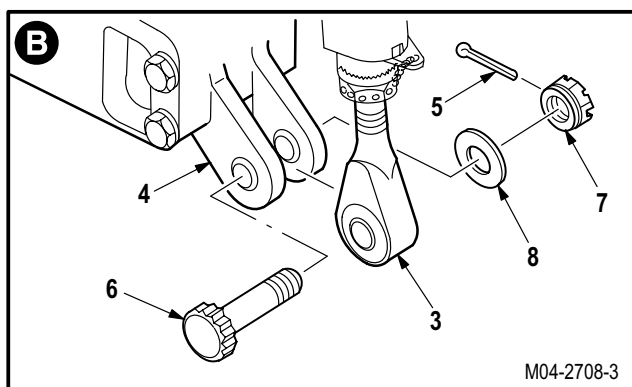

c. **Remove connector plate (9) from top plate (10).**

- (1) Remove two screws (11) and washers (12).

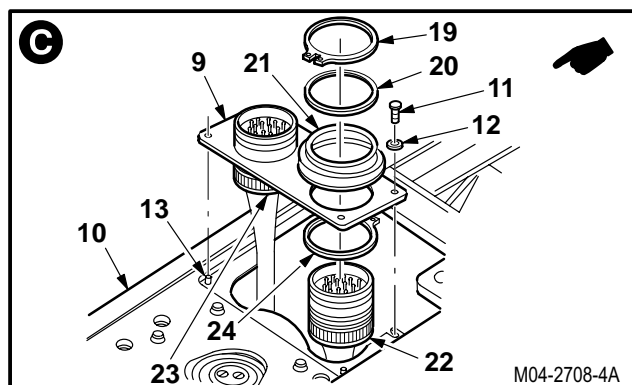

**WARNING**

**Maintain pressure on preloaded spring while removing retaining ring. A spring-loaded mechanism can cause injury to personnel if released in an uncontrolled manner. Always take care while working with the mechanism.**

- (2) Remove two connectors P505 (22) and P508 (23) from plate (9).
- (3) Maintain pressure on springs (21). Use wire (item 225, App F).
- (4) Remove retaining ring (19), backing washer (20), spring (21), and retainer (24).
- (5) Remove plate (9) from alignment pins (13).

GO TO NEXT PAGE

**16.9. PYLON ACTUATOR AND TOP PLATE REMOVAL/INSTALLATION - continued**

**d. Remove actuator (14) and plate (10) from pylon (15).**

- (1) Remove six bolts (16) with washers (17) from plate (10).
- (2) Slip plate (9) through plate (10).
- (3) Pull actuator (14) and plate (10) out top of pylon (15).

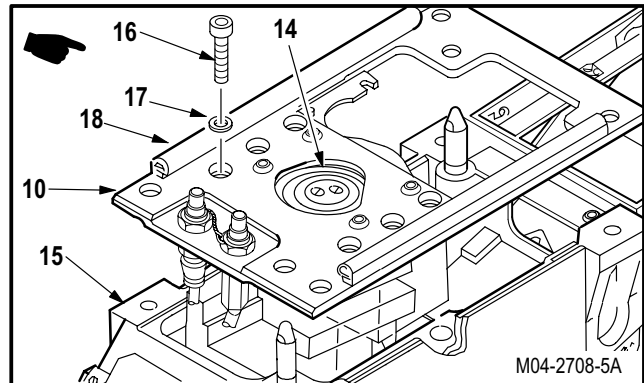

**16.9.4. Cleaning**

- a. **Wipe actuator, top plate, and mounting area with a clean rag.**

**16.9.5. Inspection**

- a. **Check elastic seal (18) for tears and excessive wear.** None allowed.
- b. **Check actuator, top plate, and mounting area for cracks.** None allowed. If cracks are suspected, perform nondestructive inspection (TM 1-1520-264-23).
- c. **Check nutplates for damage** (para 16.1).
- d. **Check actuator and top plate for sheared or damaged mounting bolts.** None allowed.
- e. **Check actuator and top plate and connector plate for corrosion** (para 1.49).
- f. **Check actuator for leaks** (para 7.2).
- e. **Check pylon yoke bushings (19) for visual wear.** If missing or visually worn, replace (para 16.25).

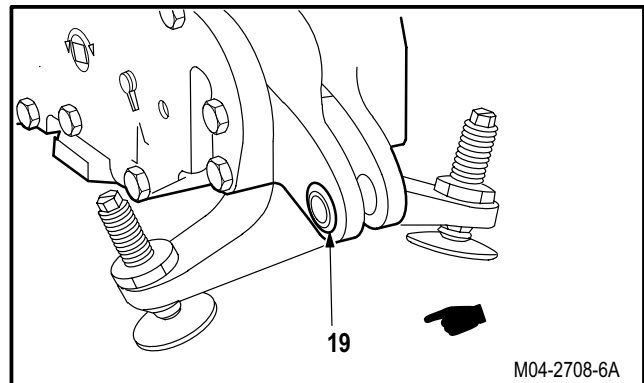

GO TO NEXT PAGE

**16.9. PYLON ACTUATOR AND TOP PLATE REMOVAL/INSTALLATION - continued**

16.9.6. Installation

a. **Install actuator (14) and plate (10) on pylon (15).**

- (1) Position actuator (14) and plate (10) on pylon (15).
- (2) Install actuator (14) and plate (10) in pylon (15). Ensure plate (9) is through plate (10).
- (3) Aline plate (9) to plate (10). Install two screws (11) and washers (12).
- (4) Aline holes. Install six bolts (16) and washers (17).

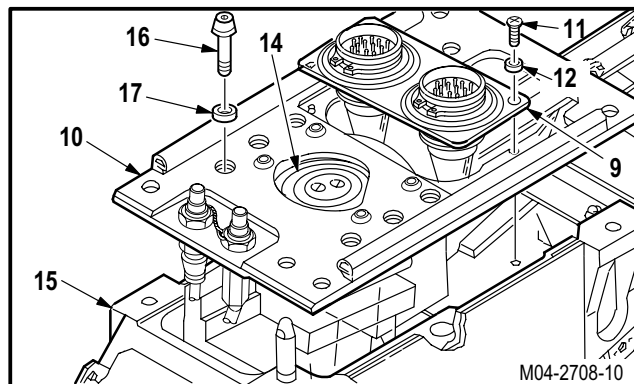

b. **Attach connector P507 (1) to receptacle J507 (2).**

c. **Install actuator rod end (3) in yoke (4). Aline holes. Torque nut (7) to 285 to 500 INCH-POUNDS.**

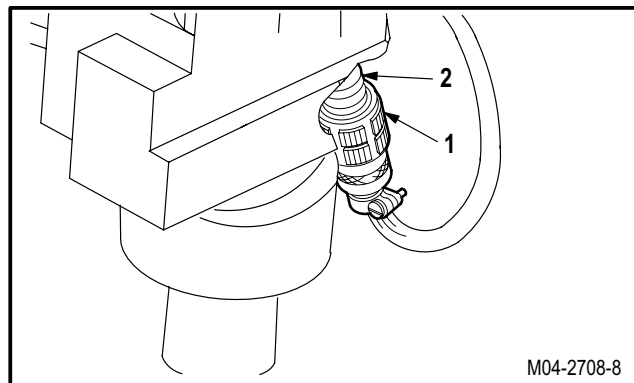

**NOTE**

If required add or remove one additional washer to aline cotter pin hole.

- (1) Install bolt (6), washer (8), and nut (7).
- (2) Hold bolt (6). Torque nut (7) to **285 INCH-POUNDS**. Use torque wrench.
- (3) Increase torque to aline cotter pin holes, but do not exceed **500 INCH-POUNDS**.
- (4) Install new cotter pin (5).

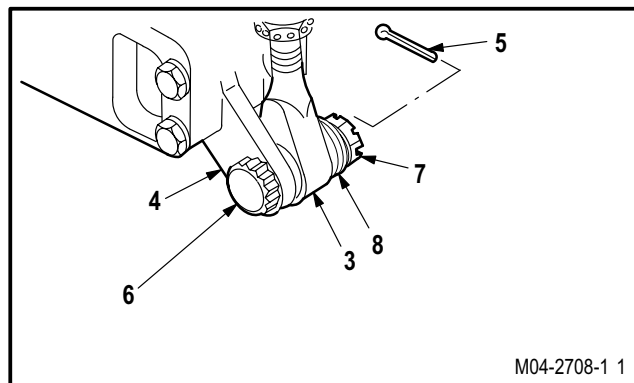

d. **Inspect (QA).**

e. **Install pylon (para 16.2).**

f. **Install pylon fairings P1, P2, and P3 (para 2.2).**

END OF TASK

**16.10. PYLON ACTUATOR HOSE AND NIPPLE REMOVAL/INSTALLATION**

16.10.1. Description

This task covers: Removal. Cleaning. Inspection. Installation.

16.10.2. Initial Setup

**Tools:**

- Electrical tool kit (item 378, App H)
- 7/8 x 3/8-inch drive open end socket wrench crowfoot attachment (item 100, App H)
- 0 - 600 inch-pound 3/8-inch drive dial indicator torque wrench (item 447, App H)

**Personnel Required:**

- 68X Armament/Electrical System Repairer
- 68X3F Armament/Electrical System Repairer/Technical Inspector

**Materials/Parts:**

- Packing
- Hydraulic fluid (item 92, App F)
- Wire (item 225, App F)

**Equipment Conditions:**

<u>Ref</u>	<u>Condition</u>
1.57	Helicopter safed
16.9	Pylon actuator and top plate removed

16.10.3. Removal

a. **Remove hose (1) from nipple (2).**

- (1) Remove lockwire from nut (3).
- (2) Hold nipple (2). Remove nut (3).

b. **Remove hose (1) from top plate (4).**

- (1) Remove lockwire from jam nut (5).
- (2) Remove nut (5) from hose (1).
- (3) Remove hose (1) from plate (4).

c. **Remove nipple (2) from actuator (6).**

- (1) Discard packing (7).

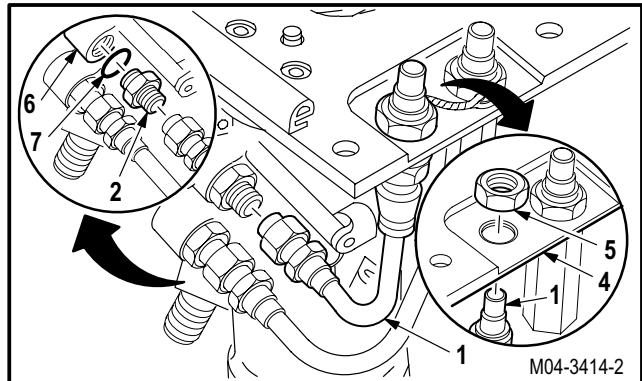
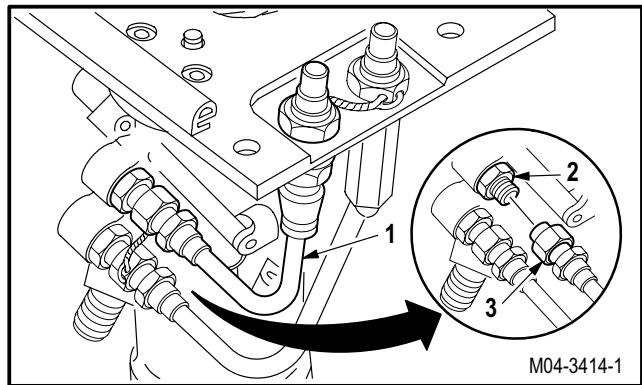

16.10.4. Cleaning

a. **Wipe hose, nipple, and mounting area with a clean rag.**

GO TO NEXT PAGE

**16.10. PYLON ACTUATOR HOSE AND NIPPLE REMOVAL/INSTALLATION - continued**

16.10.5. Inspection

- a. **Check mounting areas for cracks.** None allowed.
- b. **Check mounting areas for corrosion** (para 1.49).
- c. **Check connector for cracks, broken pins, or damaged wiring connections** (para 16.1).
- d. **Check hose for chafing, nicks, or cuts** (para 16.1).

16.10.6. Installation

- a. **Install nipple (2) in actuator (6).** Torque nipple (2) to **140 INCH-POUNDS**.



- (1) Lubricate new packing (7). Use hydraulic fluid (item 92, App F).
- (2) Install packing (7) on nipple (2).
- (3) Install nipple (2) in actuator (6).
- (4) Torque nipple (2) to **140 INCH-POUNDS**. Use adapter and torque wrench.

- b. **Install hose (1) on plate (4).** Torque nut (5) to **260 INCH-POUNDS**.

- (1) Insert hose (1) through plate (4).
- (2) Install nut (5). Torque nut (5) to **260 INCH-POUNDS**. Use torque wrench.
- (3) Lockwire nut (5) to nut (8). Use wire (item 225, App F).

- c. **Attach hose (1) to nipple (2).** Torque nut (3) to **140 INCH-POUNDS**.

- (1) Lubricate threads of nipple (2). Use hydraulic fluid (item 92, App F).
- (2) Install nut (3) on nipple (2). Torque nut (3) to **140 INCH-POUNDS**. Use crowfoot and torque wrench.
- (3) Lockwire nut (3) to nut (9). Use wire (item 225, App F).

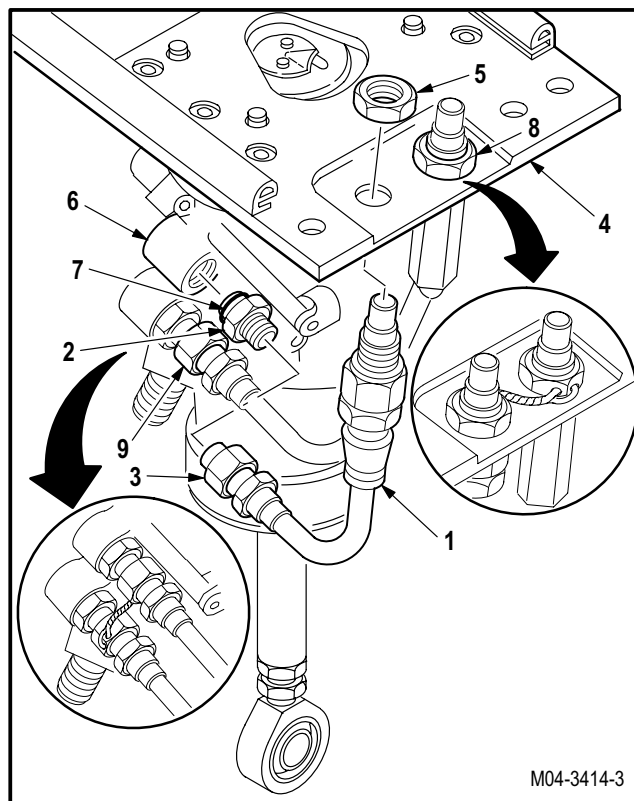

GO TO NEXT PAGE

---

**16.10. PYLON ACTUATOR HOSE AND NIPPLE REMOVAL/INSTALLATION - continued**

---

- d. **Inspect (QA).**
- e. **Install pylon actuator and top plate** (para 16.9).

END OF TASK

**16.11. PYLON ACTUATOR FILTER HOSE AND ADAPTER REMOVAL/INSTALLATION**

16.11.1. Description

This task covers: Removal. Cleaning. Inspection. Installation.

16.11.2. Initial Setup

**Tools:**

- Hydraulic tool kit (item 384, App H)
- 7/8 x 3/8-inch drive open end socket wrench crowfoot attachment (item 100, App H)
- 0 - 600 inch-pound 3/8-inch drive dial indicator torque wrench (item 447, App H)

**Personnel Required:**

- 68X Armament/Electrical System Repairer
- 68X3F Armament/Electrical System Repairer/  
Technical Inspector

**Materials/Parts:**

- Adapter
- Packing
- Hydraulic fluid (item 92, App F)
- Wire (item 225, App F)

**Equipment Conditions:**

<u>Ref</u>	<u>Condition</u>
1.57	Helicopter safed
16.9	Pylon actuator and top plate removed

16.11.3. Removal

a. **Remove filter hose (1) from filter adapter (2).**

- (1) Remove lockwire from nut (3).
- (2) Hold filter adapter (2). Remove nut (3).

b. **Remove filter hose (1) from plate (4).**

- (1) Remove lockwire from jam nut (5).
- (2) Remove nut (5) from hose (1).
- (3) Remove hose (1) from plate (4).

c. **Remove and discard adapter (2) and packing (6) from actuator (7).**

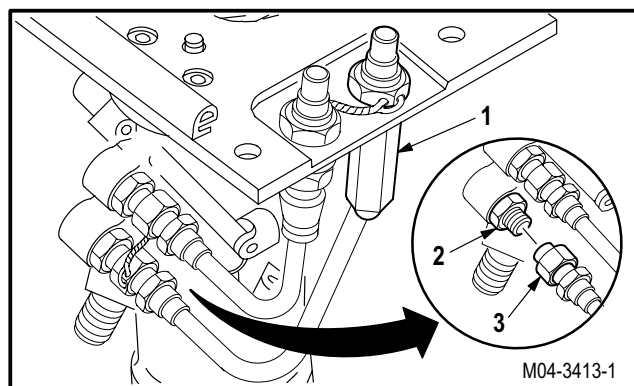

16.11.4. Cleaning

a. **Wipe filter hose and mounting area with clean rag.**

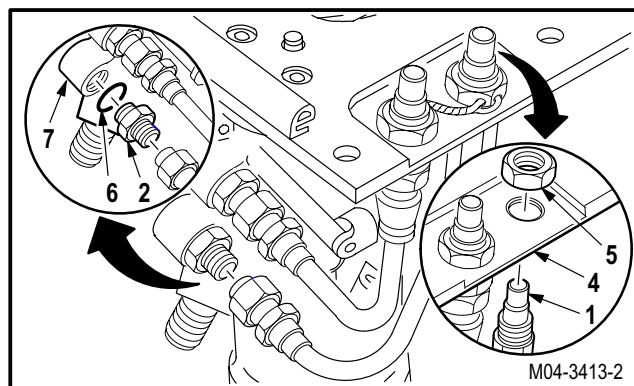

GO TO NEXT PAGE

**16.11. PYLON ACTUATOR FILTER HOSE AND ADAPTER REMOVAL/INSTALLATION - continued**

16.11.5. Inspection

- a. **Check mounting areas for cracks.** None allowed.
- b. **Check mounting areas for corrosion** (para 1.49).
- c. **Check connector for cracks, broken pins, or damaged wiring connections** (para 16.1).
- d. **Check hose for chafing, nicks, or cuts** (para 16.1).

16.11.6. Installation

- a. **Install new adapter (2) in actuator (7).** Torque adapter (2) to **230 INCH-POUNDS**.



- (1) Lubricate new packing (6). Use hydraulic fluid (item 92, App F).
- (2) Install new packing (6) on new adapter (2).
- (3) Install adapter (2) in actuator (7).
- (4) Torque adapter (2) to **230 INCH-POUNDS**. Use torque wrench.

- b. **Install hose (1) to top plate (4).** Torque nut (5) to **260 INCH-POUNDS**.

- (1) Insert hose (1) through plate (4). Install nut (5). Torque nut (5) to **260 INCH-POUNDS**. Use torque wrench.
- (2) Lockwire nut (5) to nut (8). Use wire (item 225, App F).

- c. **Attach hose (1) to adapter (2).** Torque nut (3) to **180 INCH-POUNDS**.

- (1) Lubricate threads of adapter (2). Use hydraulic fluid (item 92, App F).
- (2) Install nut (3) on adapter (2). Torque nut (3) to **180 INCH-POUNDS**. Use crowfoot and torque wrench.
- (3) Lockwire nut (3) to nut (9). Use wire (item 225, App F).

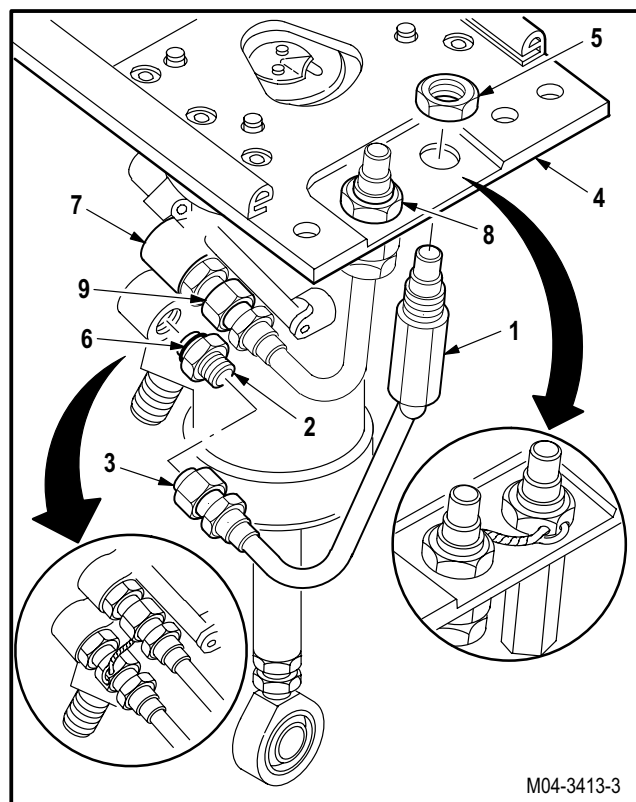

M04-3413-3

GO TO NEXT PAGE



---

**16.11. PYLON ACTUATOR FILTER HOSE AND ADAPTER REMOVAL/INSTALLATION - continued**

---

- d. **Inspect (QA).**
- e. **Install pylon actuator and top plate** (para 16.9).

END OF TASK

---

## 16.12. PYLON ACTUATOR CYLINDER REMOVAL/INSTALLATION

---

### 16.12.1. Description

This task covers: Removal. Cleaning. Inspection. Installation.

---

### 16.12.2. Initial Setup

#### Tools:

Electrical tool kit (item 378, App H)

#### Personnel Required:

68X Armament/Electrical System Repairer  
 68X3F Armament/Electrical System Repairer/  
 Technical Inspector

#### Equipment Conditions:

<u>Ref</u>	<u>Condition</u>
1.57	Helicopter safed
16.9	Pylon actuator and top plate removed
16.10	Pylon actuator hose and nipple removed
16.11	Pylon actuator filter hose adapter removed

---

### 16.12.3. Removal

#### a. Remove actuator (1) from top plate (2).

- (1) Remove two bolts (3) and washers (4).
- (2) Remove two long bolts (5) and washers (4).
- (3) Separate actuator (1) from plate (2).

### 16.12.4. Cleaning

#### a. Wipe removed and attaching parts with a clean dry rag.

### 16.12.5. Inspection

- a. Check actuator and top plate for cracks. None allowed.
- b. Check actuator and top plate for corrosion (para 1.49).

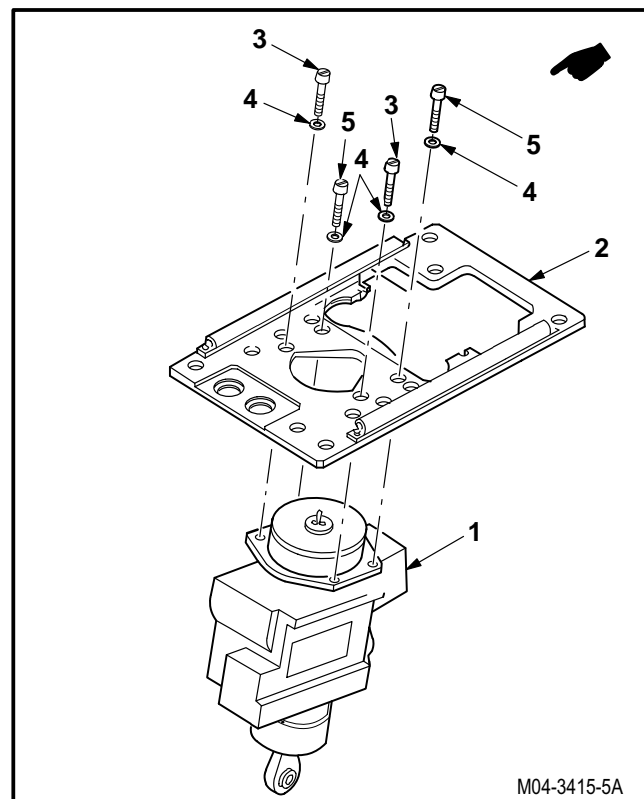

GO TO NEXT PAGE

---

**16.12. PYLON ACTUATOR CYLINDER REMOVAL/INSTALLATION - continued**

---

16.12.6. Installation**a. Install actuator (1) on plate (2).**

- (1) Aline actuator (1) with plate (2).
- (2) Install two long bolts (5) and washers (4).
- (3) Install two bolts (3) and washers (4).
- (4) Torque bolts (3) and (5) to **50 to 70 INCH-POUNDS.**

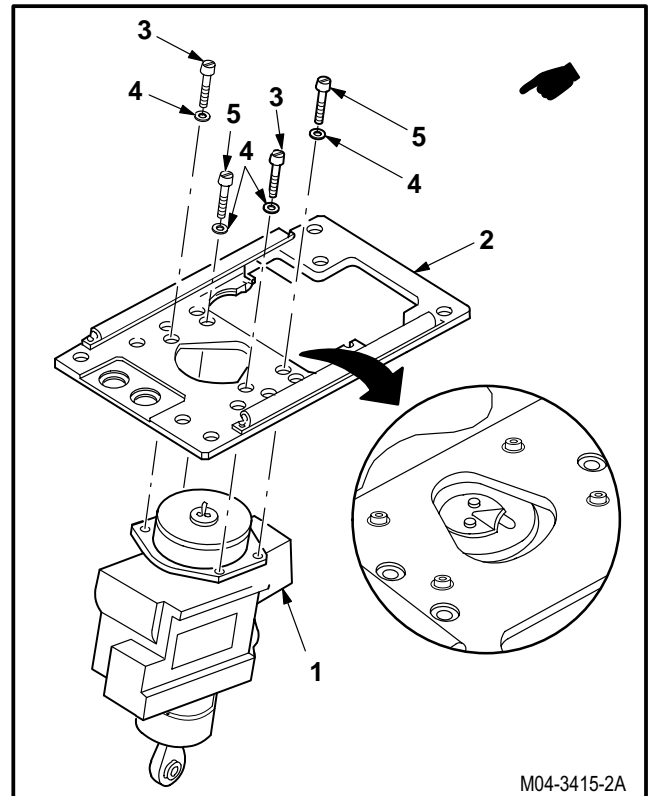
**b. Inspect (QA).****c. Install pylon actuator filter hose and adapter (para 16.11).****d. Install pylon actuator hose and nipple (para 16.10).****e. Install pylon actuator and top plate (para 16.9).**

END OF TASK

**16.13. PYLON ACTUATOR ROD END REMOVAL/INSTALLATION**

16.13.1. Description

This task covers: Removal. Cleaning. Inspection. Installation.

16.13.2. Initial Setup

**Tools:**

Electrical tool kit (item 378, App H)  
 0 - 600 inch-pound 3/8-inch drive dial indicator torque wrench (item 447, App H)

**References:**

TM 9-1230-476-20-1

**Materials/Parts:**

Cotter pin  
 Wire (item 225, App F)

**Equipment Conditions:**

**Personnel Required:**

68X Armament/Electrical System Repairer  
 68X3F Armament/Electrical System Repairer/  
 Technical Inspector

Ref

Condition

1.57	Helicopter safed
16.3	Pylon rack ejector impulse cartridge removed

16.13.3. Removal

a. **Remove actuator rod end (1) from yoke (2).**

- (1) Remove and discard cotter pin (3).
- (2) Hold bolt (4). Remove nut (5) and washer (6).
- (3) Remove bolt (4) from yoke (2) and rod end (1).
- (4) Remove rod end (1) from yoke (2).

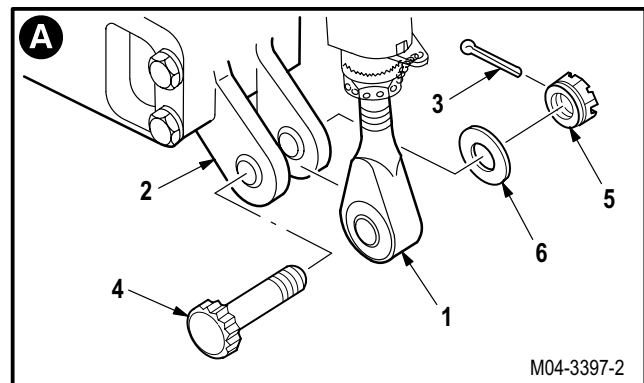
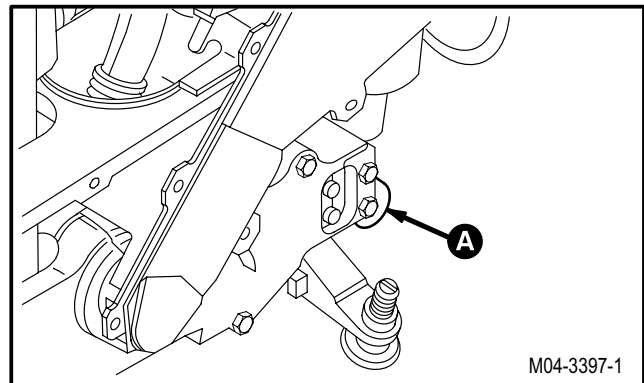

GO TO NEXT PAGE

**16.13. PYLON ACTUATOR ROD END REMOVAL/INSTALLATION - continued**

**b. Remove rod end (1) from actuator rod (7).**

- (1) Measure and record distance A between center of rod end (1) and bottom of rod (7) before removing rod end (1).
- (2) Remove lockwire from nut (8).
- (3) Hold rod (7). Loosen nut (8).
- (4) Remove rod end (1), keywasher (9), and lockwasher (10).

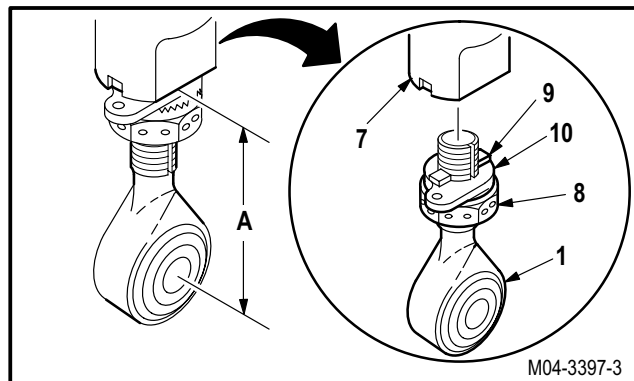

**16.13.4. Cleaning**

- a. **Wipe removed and attaching parts with clean dry rag.**

**16.13.5. Inspection**

- a. **Check rod end and actuator rod for stripped threads or cracks.** None allowed.
- b. **Check rod end and rod for corrosion** (para 1.49).
- c. **Check pylon frame yoke for damaged or worn bushings.** If damaged or worn replace bushings (para 16.25).

**16.13.6. Installation**

**CAUTION**

Rod end shaft must block inspection hole in actuator rod after adjustment.

**a. Install rod end (1) in rod (7).**

- (1) Thread nut (8) on rod end (1).
- (2) Aline tab (11) on lockwasher (10) with groove (12) on rod end (1).
- (3) Install lockwasher (10) on rod end (1).
- (4) Install keywasher (9) on rod end (1).
- (5) Aline teeth (13) of keywasher (9) and lockwasher (10).

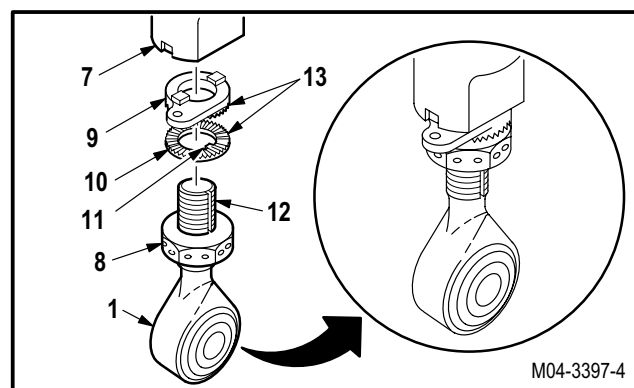

GO TO NEXT PAGE

**16.13. PYLON ACTUATOR ROD END REMOVAL/INSTALLATION - continued**

(6) Install rod end (1), nut (8), lockwasher (10), and keywasher (9) in rod (7).

(7) Adjust rod end (1) to recorded measurement.

**b. Install rod end (1) in yoke (2).**

(1) Install bolt (4) through yoke (2) and rod end (1).

(2) Install washer (6) and nut (5).

**c. Perform pylon boresight**  
(TM 9-1230-476-20-1).

**CAUTION**

Rod end shaft must block inspection hole in actuator rod after adjustment.

**NOTE**

Perform steps d. thru k. if rod end adjustment is necessary.

**d. Adjust rod end (1) by turning rod (7) to move the rod end (1) up or down.**

**e. Slide keywasher (9) and lockwasher (10) toward rod (7).**

**f. Aline tabs (14) of keywasher (9) with grooves (15) of rod (7).**

**NOTE**

Ensure tab washer and lockwasher teeth aline.

**g. Hold rod (7).** Tighten nut (8).

**h. Tighten rod end (1).** Torque nut (5) **285 to 500 INCH-POUNDS.**

(1) Hold bolt (4). Torque nut (5) to **285 INCH-POUNDS.** Use torque wrench.

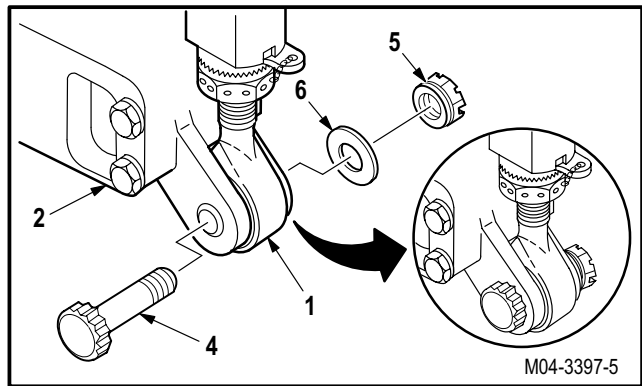
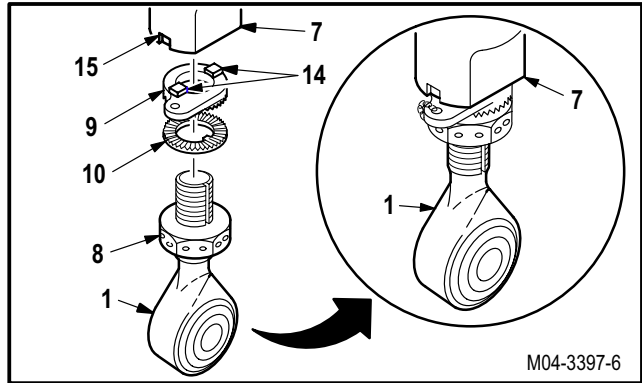

GO TO NEXT PAGE

---

**16.13. PYLON ACTUATOR ROD END REMOVAL/INSTALLATION - continued**

---

- (2) Increase torque to aline cotter pin holes, but do not exceed **500 INCH-POUNDS**.
- (3) Install new cotter pin (3) in nut (5).

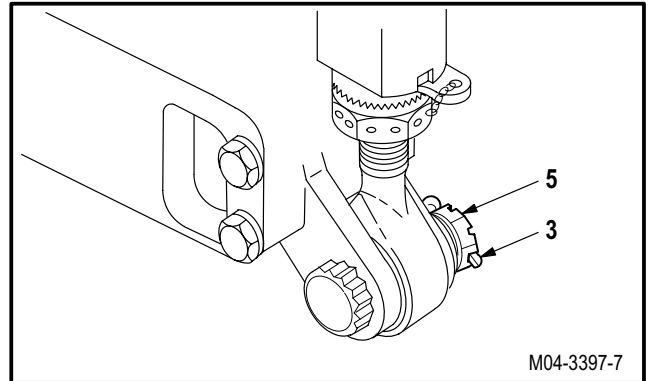

- i. **Lockwire nut (8) to keywasher (9).** Use wire (item 225, App F).
- j. **Inspect (QA).**
- k. **Install pylon rack ejector impulse cartridge** (para 16.3).

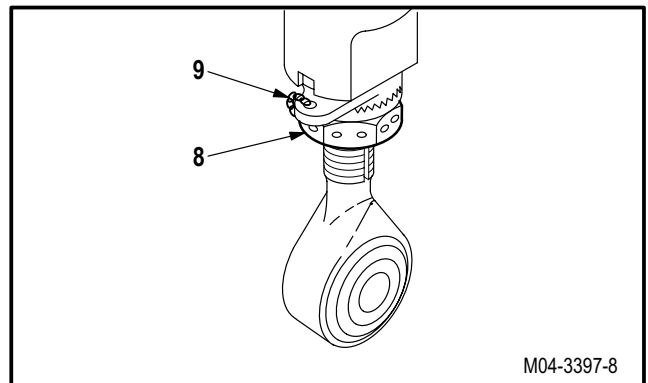

END OF TASK

---

## 16.14. PYLON AERIAL BRACKET REMOVAL/INSTALLATION

---

### 16.14.1. Description

This task covers: Removal. Cleaning. Inspection. Installation.

---

### 16.14.2. Initial Setup

#### **Tools:**

Electrical tool kit (item 378, App H)  
Retaining ring pliers (item 227, App H)

#### **References:**

TM 9-1090-208-23-1  
TM 55-1500-323-24

#### **Materials/Parts:**

Wire (item 229, App F)

#### **Equipment Conditions:**

#### **Personnel Required:**

68X Armament/Electrical System Repairer  
68X3F Armament/Electrical System Repairer/  
Technical Inspector

#### Ref

2.2

TM 9-1090-208-23-1

#### Condition

Pylon fairing P1, P2, and  
P3 removed

Station director removed

---

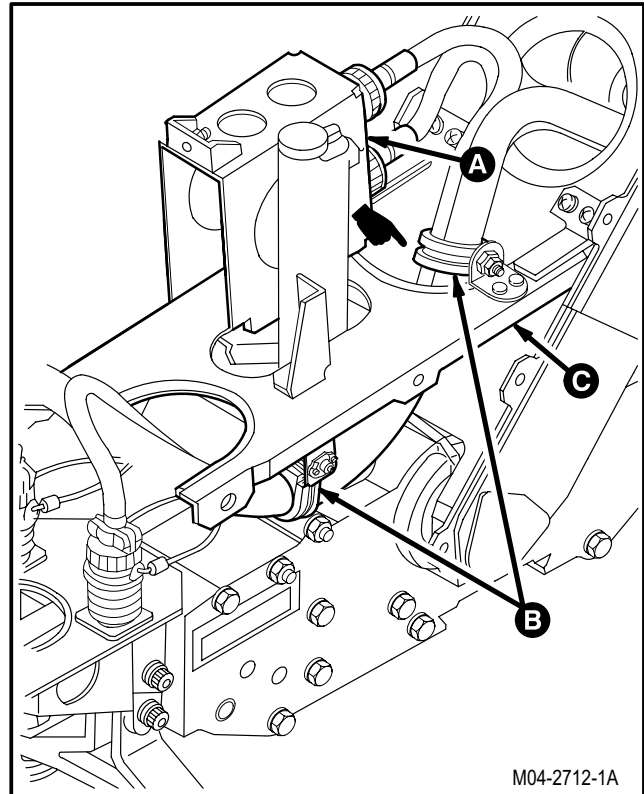

GO TO NEXT PAGE



---

**16.14. PYLON AERIAL BRACKET REMOVAL/INSTALLATION - continued**

---

16.14.3. Removal

**WARNING**

**Maintain pressure on preloaded spring while removing retaining ring. A spring-loaded mechanism can cause injury to personnel if released in an uncontrolled manner. Always take care while working with the mechanism.**

- a. **Wrap lockwire around two springs (1) at three places.**

(1) Evenly space lockwire to hold spring (1) fully compressed. Use wire (item 229, App F).

- b. **Remove connector P510 (2) and connector P525 (3) from aerial bracket (4).**

(1) Remove retaining ring (5), backing washer (6), and spring (1) from connector P510 (2). Use retaining ring pliers.

(2) Remove retaining ring (5), backing washer (6) and spring (1) from connector P525 (3). Use retaining ring pliers.

(3) Remove connector P510 (2), connector P525 (3), and retaining rings (7) from bracket (4).

- c. **Remove clamps (8) and (9) from bracket (4).**

(1) Remove two screws (10) and washers (11).

(2) Remove clamps (8) and (9).

- d. **Remove circuit card (12) from bracket (4).**

(1) Remove two screws (13) and washers (14).

(2) Remove circuit card (12).

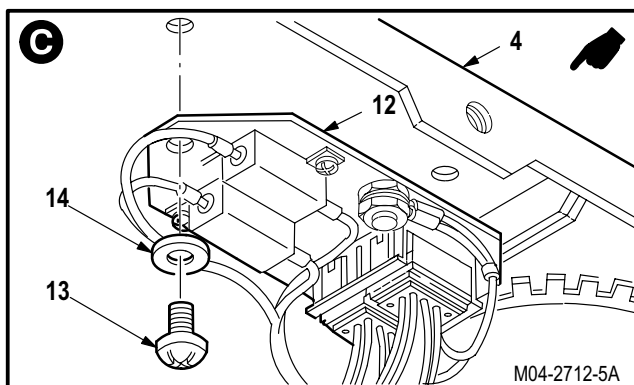
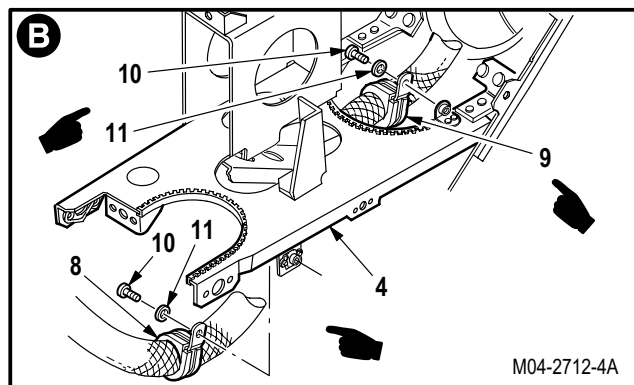
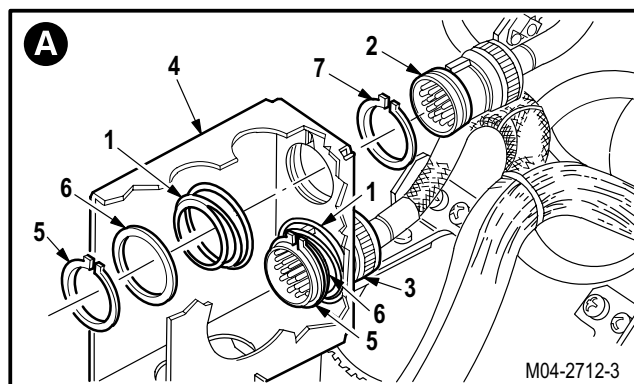

GO TO NEXT PAGE

**16.14. PYLON AERIAL BRACKET REMOVAL/INSTALLATION - continued**

**e. Remove bracket (4) from pylon frame (15).**

- (1) Remove four screws (16) and washers (17).
- (2) Remove screw (18), washer (19), and lead (20).
- (3) Remove bracket (4).

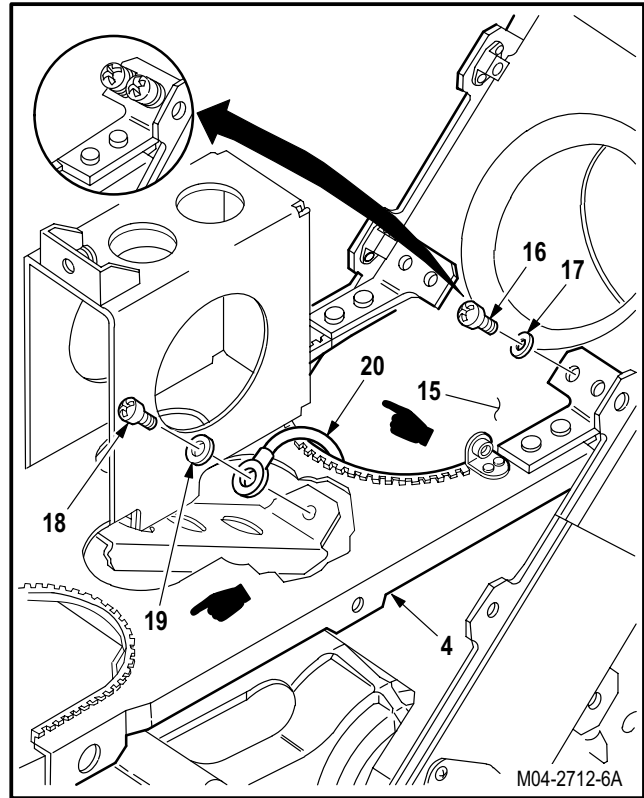

16.14.4. Cleaning

- a. **Wipe bracket with a clean rag.**

16.14.5. Inspection

- a. **Check connector for cracks, broken pins, or damaged wiring connections** (para 16.1).
- b. **Check circuit card for broken wires, connectors, or clamps** (TM 55-1500-323-24).
- c. **Check bracket for cracks** (para 16.1).
- d. **Check fasteners for damage** (para 16.1).
- e. **Check bracket for corrosion** (para 1.49).

16.14.6. Installation

**a. Install bracket (4) on frame (15).**

- (1) Position bracket (4) on frame (15). Aline screw holes.
- (2) Install four screws (16) and washers (17).

**b. Install card (12) on bracket (4).**

- (1) Position card (12) on bottom of bracket (4). Aline screw holes.
- (2) Install two screws (13) and washers (14).

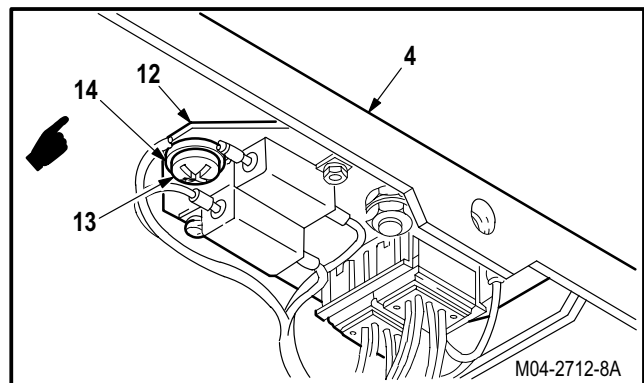

GO TO NEXT PAGE

---

**16.14. PYLON AERIAL BRACKET REMOVAL/INSTALLATION - continued**

---

**c. Install clamps (8) and (9) on bracket (4).**

- (1) Install two screws (10) and washers (11).

**WARNING**

**Maintain pressure on preloaded spring while installing retaining ring. A spring-loaded mechanism can cause injury to personnel if released in an uncontrolled manner. Always take care while working with the mechanism.**

**NOTE**

Do not perform step d if installing original spring.

**d. Compress two springs (1) in vise (21).**

- (1) Wrap lockwire around spring (1), three places.
- (2) Evenly space lockwire to hold spring (1) compressed. Use wire (item 229, App F).
- (3) Position and compress spring (1) in vise (21).
- (4) Tighten lockwire.
- (5) Remove spring (1) from vise (21).

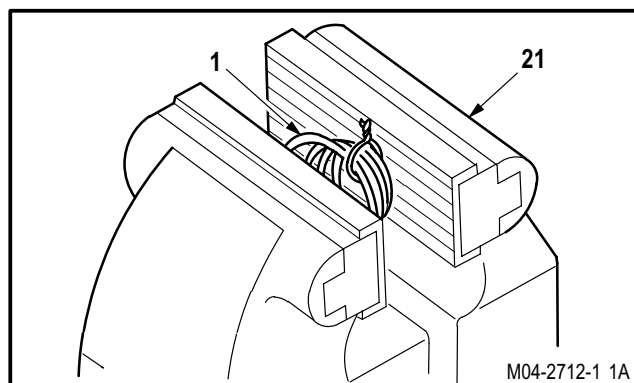
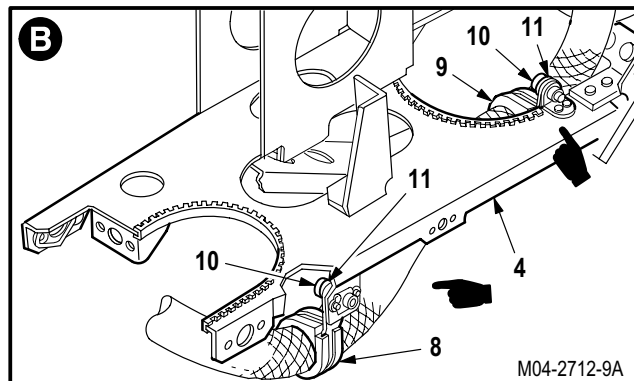

GO TO NEXT PAGE

**16.14. PYLON AERIAL BRACKET REMOVAL/INSTALLATION - continued**

**e. Install connector P510 (2) on bracket (4).**

- (1) Install ring (7) on connector P510 (2) with ring lugs (22) pointing up. Use retaining ring pliers.
- (2) Aline keyway (23) of connector P510 (2) with keyway (24) on bracket (4).
- (3) Insert connector P510 (2) on bracket (4) until ring (7) is against bracket (4).
- (4) Install spring (1), washer (6), and retaining ring (5) on connector P510 (2). Use retaining ring pliers.
- (5) Remove lockwire from spring (1).

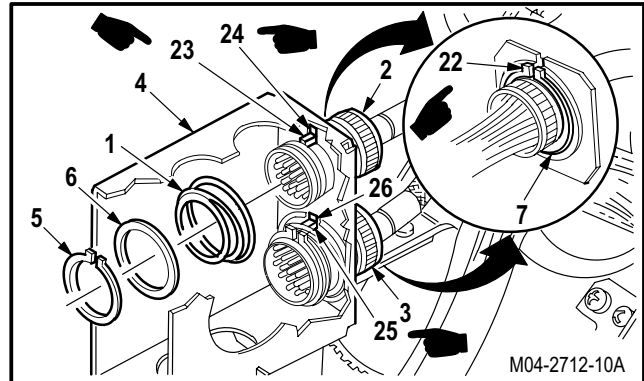

**f. Install connector P525 (3) on bracket (4).**

- (1) Install ring (7) on connector P525 (3) with ring lugs (22) pointing up. Use retaining ring pliers.
- (2) Aline keyway (25) of connector P525 (3) with keyway (26) on bracket (4).
- (3) Insert connector P525 (3) on bracket (4) until ring (7) is against bracket (4).
- (4) Install spring (1), washer (6), and retaining ring (5) on connector P525 (3). Use retaining ring pliers.
- (5) Remove lockwire from spring (1).

**g. Inspect (QA).**

**h. Install station director (TM 9-1090-208-23-1).**

**i. Install pylon fairings P1, P2, and P3 (para 2.2).**

END OF TASK

**16.15. PYLON CONTROLLER AND CONTROLLER BRACKET REMOVAL/INSTALLATION**

16.15.1. Description

This task covers: Removal. Cleaning. Inspection. Installation.

16.15.2. Initial Setup

**Tools:**

Electrical tool kit (item 378, App H)  
Retaining ring pliers (item 227, App H)

**References:**

TM 9-1090-208-23-2

**Equipment Conditions:**

<u>Ref</u>	<u>Condition</u>
1.57	Helicopter safed
2.2	Pylon fairing P3 removed
16.3	Pylon rack ejector impulse cartridge removed

**Personnel Required:**

68X Armament/Electrical System Repairer  
One person to assist  
68X3F Armament/Electrical System Repairer/  
Technical Inspector

16.15.3. Removal

- a. Remove pylon controller (1) from pylon controller bracket (2).

(1) Unlock two captive fasteners (3).

**NOTE**

Go to paragraph 16.15.4 if only controller is being replaced.

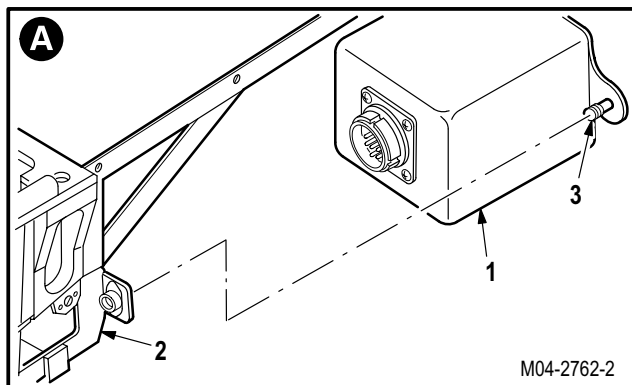
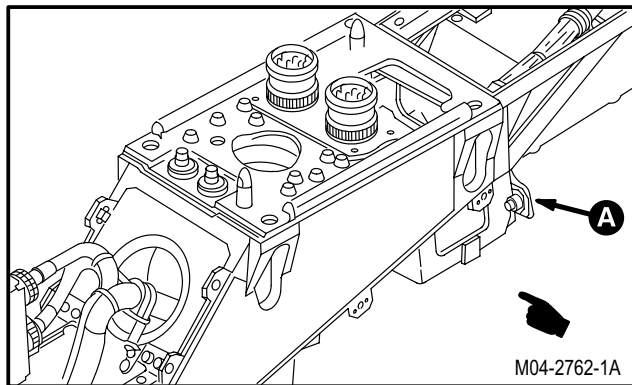

GO TO NEXT PAGE

16.15. PYLON CONTROLLER AND CONTROLLER BRACKET REMOVAL/INSTALLATION - continued

b. Remove bracket (2) from pylon frame (4).

- (1) Remove four cap screws (5) and washers (6).
- (2) Remove bracket (2).

**WARNING**

**Maintain pressure on preloaded spring while removing retaining ring. A spring-loaded mechanism can cause injury to personnel if released in an uncontrolled manner. Always take care while working with the mechanism.**

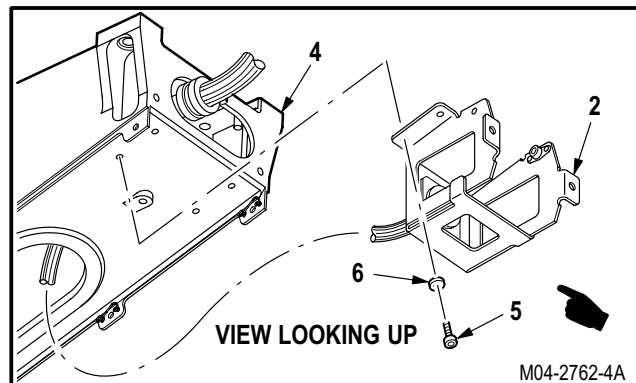

c. Detach connector P506 (8) from bracket (2).

- (1) Apply pressure to aft side of connector (8). Use handle of hammer (9) (similar object may be used if made of wood) to decrease tension on retainer ring (10). Remove retainer ring (10) from forward side of connector (8). Use retaining ring pliers.

- (2) Slowly reduce pressure on connector (8).

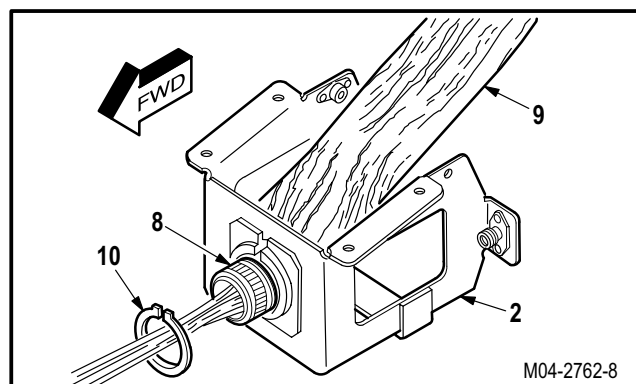

- (3) Remove retainer ring (11) from aft side of connector (8). Use retaining ring pliers.

- (4) Remove washer (12) and spring (13) from connector (8).

- (5) Detach connector (8) from bracket (2).

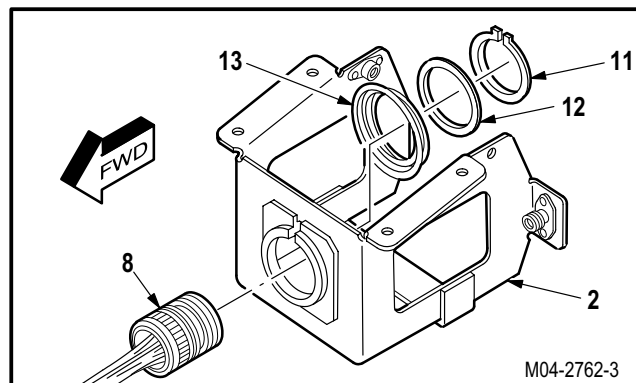

16.15.4. Cleaning

- a. **Wipe controller, bracket, and attachment area with a clean rag.**

GO TO NEXT PAGE

**16.15. PYLON CONTROLLER AND CONTROLLER BRACKET REMOVAL/INSTALLATION - continued**

16.15.5. Inspection

- a. **Check mounting bracket and connector P506 for cracks.** None allowed.
- b. **Check nutplates damage** (para 16.1).
- c. **Check mounting bracket for corrosion** (para 1.49).

16.15.6. Installation

**WARNING**

**Maintain pressure on preloaded spring while installing retaining ring. A spring-loaded mechanism can cause injury to personnel if released in an uncontrolled manner. Always take care while working with the mechanism.**

**NOTE**

Go to step c if only controller is being installed.

a. **Attach connector P506 (8) on bracket (2).**

- (1) Route connector (8) through bracket (2). Ensure connector (8) is aligned with key on bracket (2).
- (2) Place spring (13) and washer (12) on aft side of connector (8).
- (3) Install retainer ring (11). Use retaining ring pliers.
- (4) Apply pressure to aft side of connector (8). Use handle of hammer (9) (a similar object may be used if made of wood) to maintain tension on spring (13). Install retainer ring (10) on forward side of connector (8). Use retaining ring pliers.

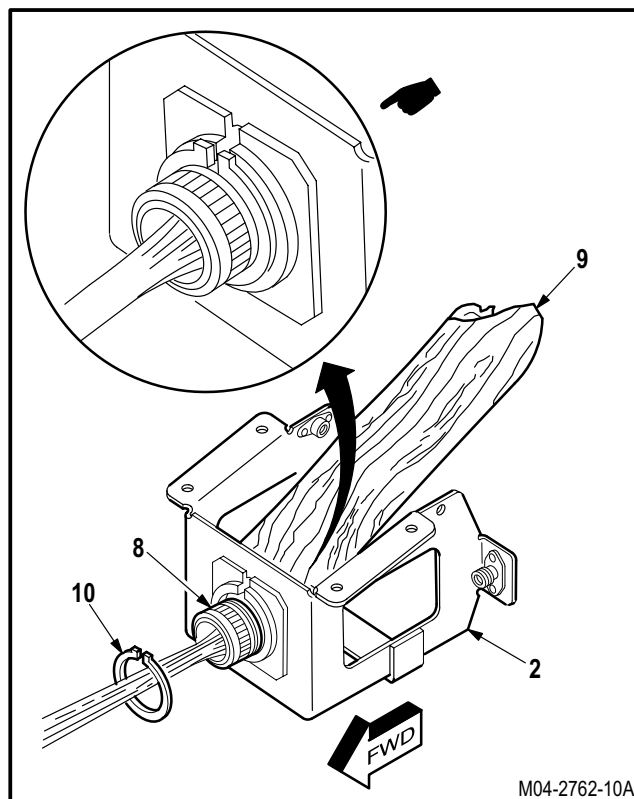
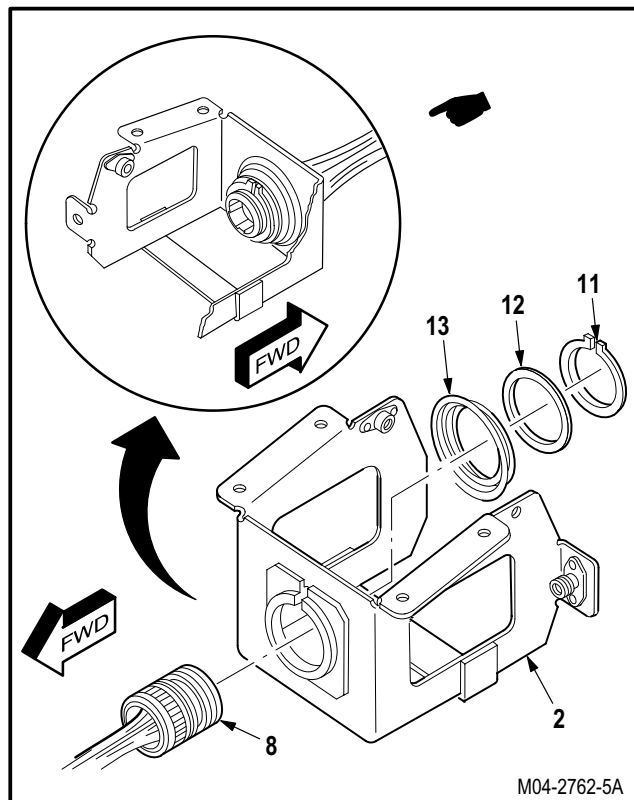

GO TO NEXT PAGE

**16.15. PYLON CONTROLLER AND CONTROLLER BRACKET REMOVAL/INSTALLATION - continued**

**b. Install bracket (2) on frame (4).**

- (1) Aline holes in bracket (2) with holes in frame (4).
- (2) Install cap screws (7) with washers (6) through bracket (2) on frame (4).
- (3) Install cap screws (5) with washers (6) through bracket (2) on frame (4).

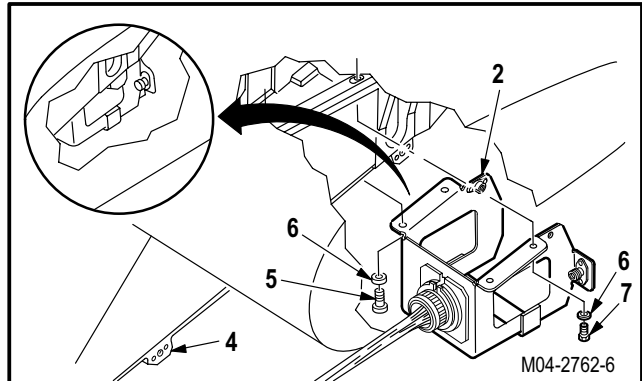

**c. Install controller (1) in bracket (2).**

- (1) Position controller (1) on bracket (2). Ensure electrical receptacle on controller (1) is properly aligned with electrical connector (8) on bracket (2).
- (2) Lock two captive fasteners (3).

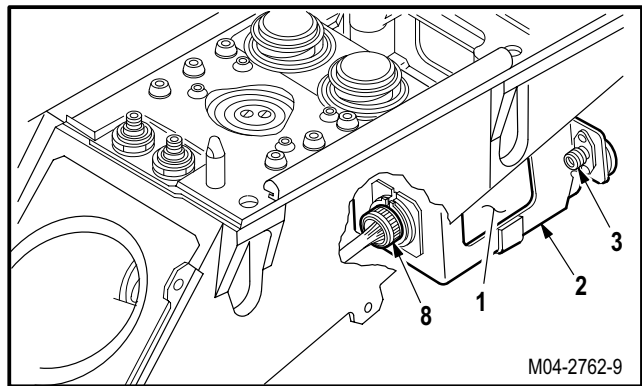

**d. Inspect (QA).**

**e. Perform external stores system maintenance operational check (TM 9-1090-208-23-2).**

**f. Install pylon fairing P3 (para 2.2).**

**g. Install pylon rack ejector impulse cartridge (para 16.3).**

END OF TASK



**16.16. PYLON MULTIPLEX REMOTE TERMINAL UNIT (MRTU) BRACKET  
REMOVAL/INSTALLATION**

16.16.1. Description

This task covers: Removal. Cleaning. Inspection. Installation.

16.16.2. Initial Setup

**Tools:**

- Electrical tool kit (item 378, App H)
- 5X & 12X monocular magnifier (item 206, App H)

**References:**

TM 9-1230-476-20-1

**Equipment Conditions:**

<u>Ref</u>	<u>Condition</u>
2.2	Pylon fairings P2 and P3 removed
16.9	Pylon actuator and top plate removed
TM 9-1230-476-20-1	Multiplex remote terminal unit (MRTU) removed

**Personnel Required:**

- 68X Armament/Electrical System Repairer
- 68X3F Armament/Electrical System Repairer/  
Technical Inspector

16.16.3. Removal

a. **Remove MRTU bracket (1) from pylon frame (2).**

- (1) Remove two nuts (3), washers (4), and screws (5) from two wire harness clamps (6).

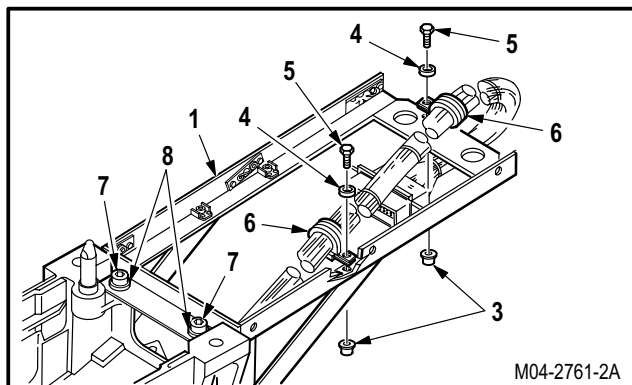

- (2) Remove four screws (7) and washers (8) from pylon frame (2).

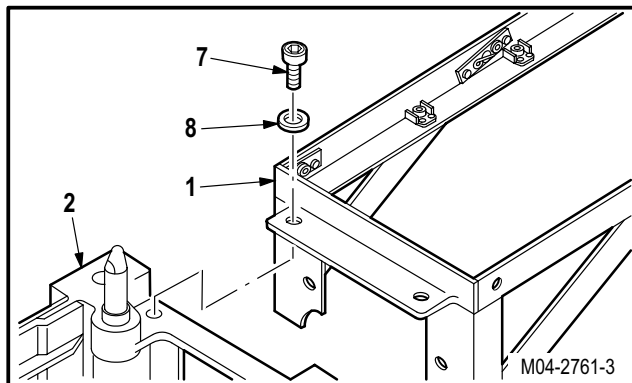

GO TO NEXT PAGE

**16.16. PYLON MULTIPLEX REMOTE TERMINAL UNIT (MRTU) BRACKET  
REMOVAL/INSTALLATION - continued**

16.16.4. Cleaning

- a. **Wipe bracket with a clean rag.**

16.16.5. Inspection

- a. **Check bracket and receptacles for cracks.**  
None allowed.
- b. **Check nutplates and receptacles for damage**  
(para 16.1).
- c. **Check bracket for corrosion** (para 1.49).
- d. **Check bracket corners and welds for separation.** Use magnifier (para 16.1)

16.16.6. Installation

- a. **Install bracket (1) on frame (2).**

- (1) Position bracket (1) on frame (2) and align screw holes.
- (2) Install four screws (7) and washers (8).

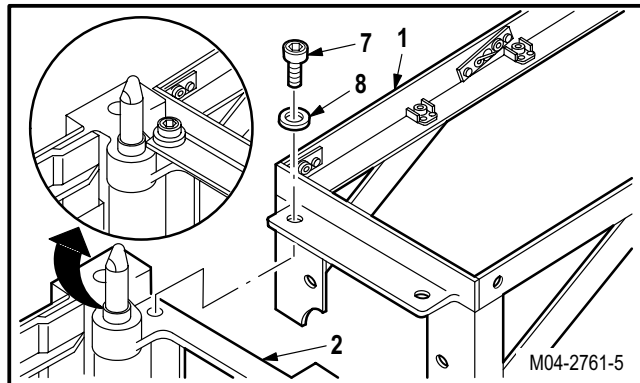

- b. **Install two clamps (6) on bracket (1).**

- (1) Position clamps (6) on bracket (1) and align screw hole.
- (2) Install two screws (5), washers (4), and nuts (3).

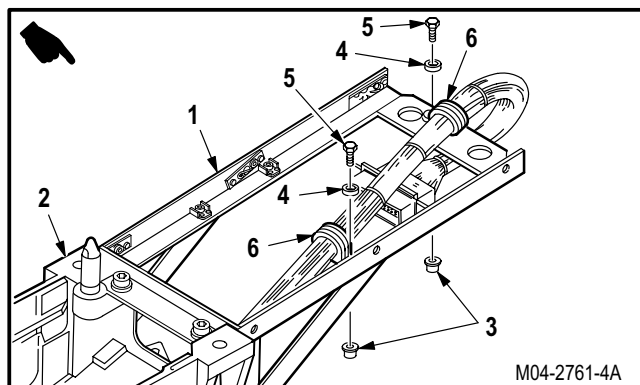

- c. **Inspect (QA).**

- d. **Install actuator and top plate assembly** (para 16.9).

- e. **Install MRTU** (TM 9-1230-476-20-1).

- f. **Install pylon fairings P2 and P3** (para 2.2).

END OF TASK

## 16.17. PYLON STOW BRACKET REMOVAL/INSTALLATION

### 16.17.1. Description

This task covers: Removal. Cleaning. Inspection. Repair. Installation.

### 16.17.2. Initial Setup

#### Tools:

Airframe repairman's tool kit (item 377, App H)  
 Electrical tool kit (item 378, App H)  
 0 - 600 inch-pound 3/8-inch drive dial indicator torque wrench (item 447, App H)

#### Personnel Required:

68G Aircraft Structural Repairer  
 68X Armament/Electrical System Repairer  
 68X3F Armament/Electrical System Repairer/  
 Technical Inspector

#### References:

TM 1-1500-204-23

#### Equipment Conditions:

Ref	Condition
1.57	Helicopter safed
2.2	Pylon fairing P1 opened
16.3	Pylon rack ejector impulse cartridge removed
16.18	Connectors and wire harness detached from stow bracket

### 16.17.3. Removal

#### a. Remove bracket (1) from pylon rack (2).

- (1) Remove nut (3) and two washers (4) from lower bolt (5).
- (2) Remove bolt (5), washer (4), and washer (6).
- (3) Remove nut (7) washer (8) and washer (9) from top bolt (10).
- (4) Remove bolt (10) washer (9), and washer (8).
- (5) Remove nut (3) and washers (4) from center bolt (11).
- (6) Remove bolt (11) washer (4) and washer (6).
- (7) Remove stow bracket (1) and forward sway brace (29) from rack (2).

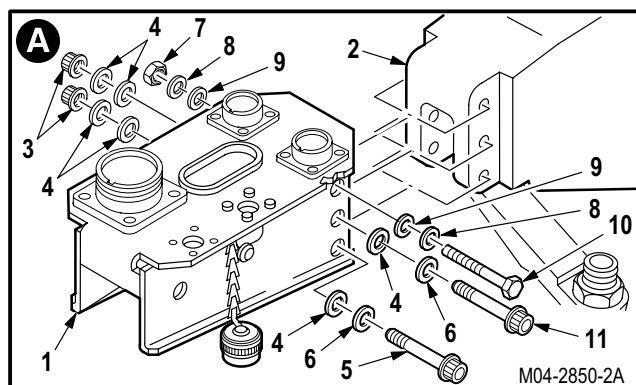
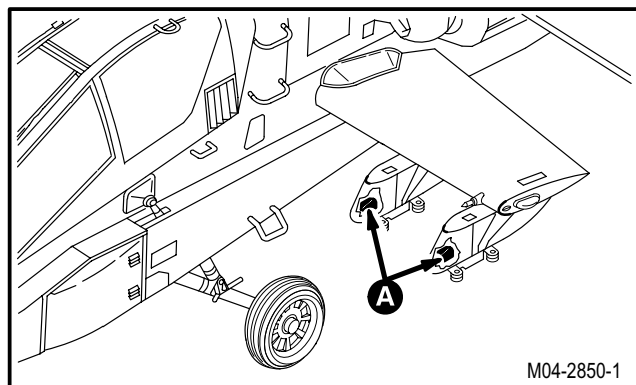

GO TO NEXT PAGE

**16.17. PYLON STOW BRACKET REMOVAL/INSTALLATION - continued**

16.17.4. Cleaning

- a. **Wipe stow bracket and mounting area with a clean rag.**

16.17.5. Inspection

- a. **Check bracket for cracks.** None allowed.
- b. **Check bracket and mounting area for warps.** None allowed.
- c. **Check bracket for corrosion** (para 1.49).
- d. **Check stow bracket receptacles for damage** (para 16.1).

16.17.6. Repair

- a. **Repair bracket cracks** (TM 1-1500-204-23).

**NOTE**

The removal and installation of these four receptacles is typical.

- b. **Repair bracket (1) by replacing dummy receptacle J511 (12), J512 (13), J513 (14), or J526 (15).**

- (1) Remove cover (16) from receptacle (15).
- (2) Remove four screws (17), eight washers (18), and four nuts (19).
- (3) Remove cover chain (20) and cover (16).
- (4) Remove and discard receptacle (12), (13), (14), or (15) from bracket (1).
- (5) Wipe receptacle mounting area with a clean rag.
- (6) Position new receptacles (12), (13), (14), or (15) on bracket (1) with keyway (21) facing forward.
- (7) Install top receptacles (12), (13), and (14).
- (8) Install eight washers (18) and four nuts (19) on four screws (17).

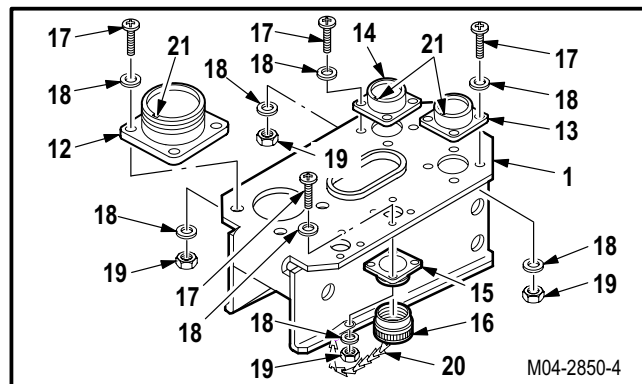
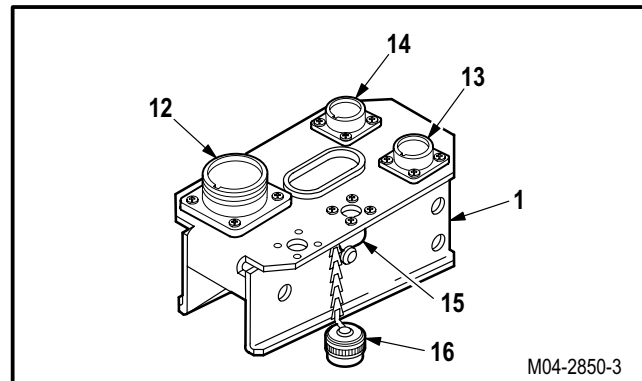

GO TO NEXT PAGE

**16.17. PYLON STOW BRACKET REMOVAL/INSTALLATION - continued**

- (9) Install bottom receptacle (15).
  - (a) Install forward outboard screw (17).
  - (b) Install cover chain (20) on forward outboard screw (17).
  - (c) Install three screws (17), eight washers, (18), and four nuts (19).
- (10) Install cover (16) on connector (15).

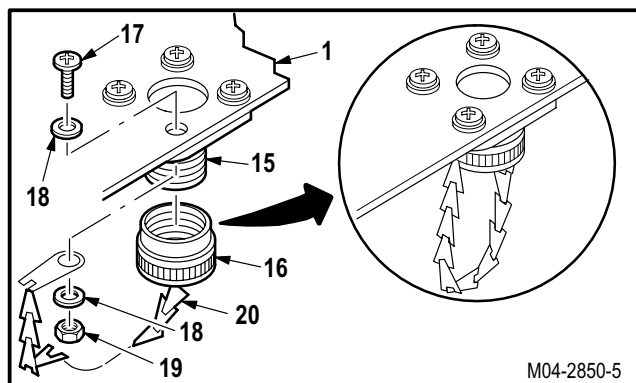

**c. Repair bracket (1) by replacing cover (16) and chain (20).**

- (1) Remove cover (16) from receptacle (15).
- (2) Remove nut (19) and washer (18) from receptacle mounting screw (17).
- (3) Remove and discard cover (16) and chain (20).
- (4) Wipe receptacle (15) with a clean rag.
- (5) Install new cover (16) with chain (20) on receptacle (15).
- (6) Install chain (20), washer (18), and nut (19) on mounting screw (17).
- (7) Install cover (16) on receptacle (15).

**d. Repair bracket (1) by replacing quick-release pin (22) or lanyard (23).**

- (1) Remove screw (24), nut (25), and washer (26).
- (2) Remove and discard lanyard (23) or pin (22) from ring (27).
- (3) Install new lanyard (23) or new pin (22) on ring (27).
- (4) Insert screw (24) through two lanyard tabs (28). Install screw (24) on bracket (1).
- (5) Hold screw (24). Install washer (26) and nut (25).

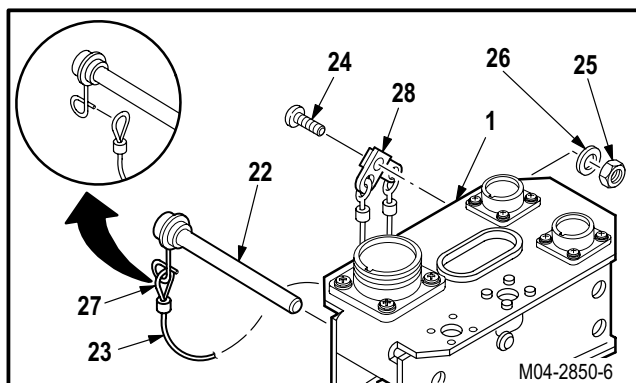

GO TO NEXT PAGE

**16.17. PYLON STOW BRACKET REMOVAL/INSTALLATION - continued**

16.17.7. Installation

a. **Install forward brace bracket (1) on frame (2).**  
Torque nuts (3) to **225 INCH-POUNDS**.

- (1) Position bracket (1) on frame (2) and align holes.
- (2) Insert bolt (11) with washer (6) and washer (4) through center hole.
- (3) Install washers (4) and nut (3) on bolt (11).
- (4) Insert bolt (10) washer (8) and washer (9) through top hole.
- (5) Install washer (9) washer (8) and nut (7).
- (6) Insert bolt (5) with washer (6) and washer (4) through bottom hole.
- (7) Hold bolt (5). Torque nut (3) to **225 INCH-POUNDS**. Use torque wrench.
- (8) Hold bolt (11). Torque nut (3) to **225 INCH-POUNDS**. Use torque wrench.

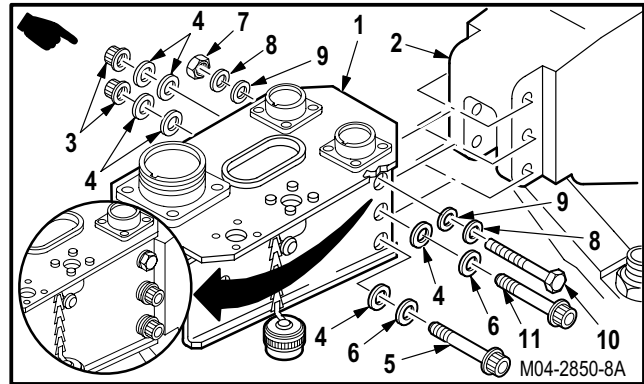

- b. **Attach all connectors and wire harness to stow bracket** (para 16.18).
- c. **Inspect (QA).**
- d. **Secure pylon fairing P1** (para 2.2).
- e. **Install pylon rack ejector impulse cartridge** (para 16.3).

END OF TASK

## 16.18. PYLON WIRE HARNESS REPLACEMENT

### 16.18.1. Description

This task covers: Removal. Cleaning. Installation.

### 16.18.2. Initial Setup

#### Tools:

Electrical tool kit (item 378, App H)  
Retaining ring pliers (item 227, App H)

#### References:

TM 9-1230-476-20-1  
TM 55-1500-323-24

#### Materials/Parts:

Strap (item 193, App F)  
Wire (item 229, App F)

#### Equipment Conditions:

Ref	Condition
TM 9-1230-476-20-1	Multiplex remote terminal unit type II removed
16.15	Pylon controller and controller bracket removed
16.9	Pylon actuator and top plate removed
16.14	Pylon aerial bracket removed

#### Personnel Required:

68X Armament/Electrical System Repairer  
68X3F Armament/Electrical System Repairer/  
Technical Inspector

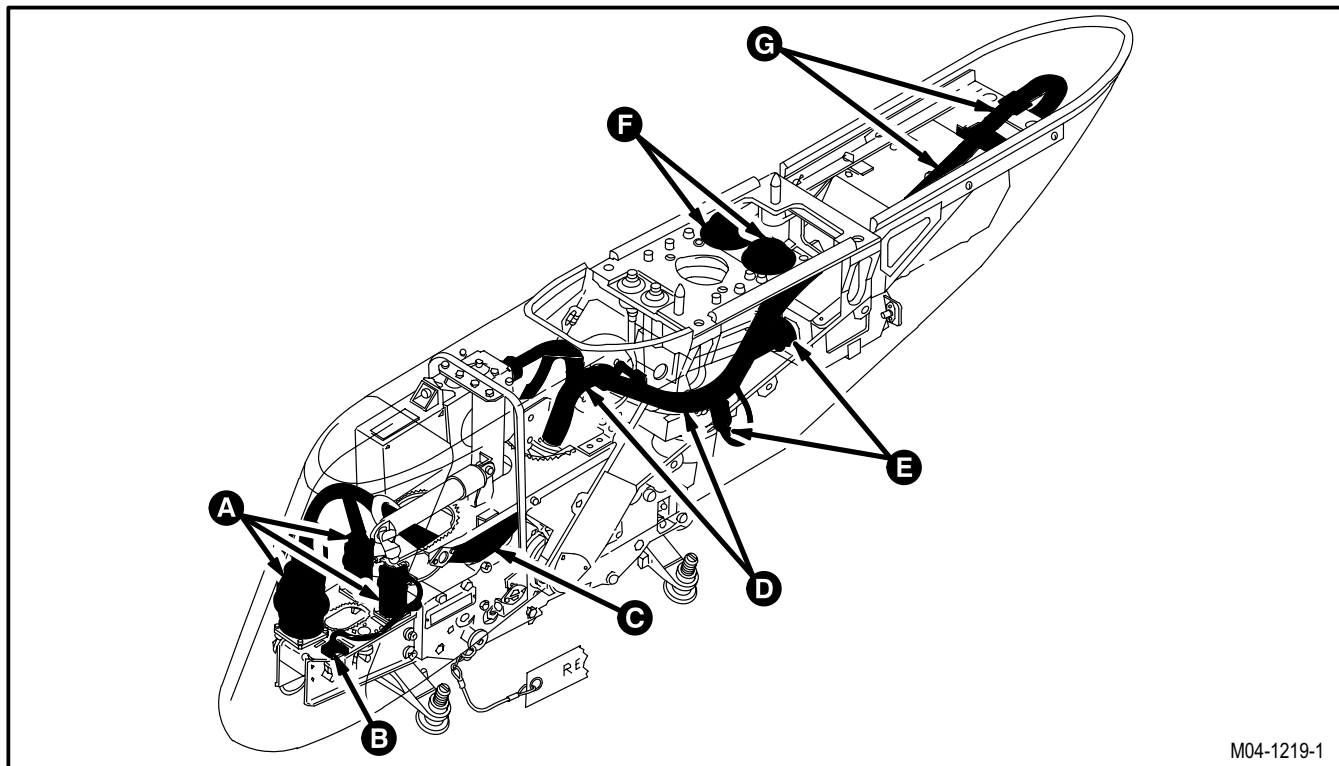

M04-1219-1

GO TO NEXT PAGE

**16.18. PYLON WIRE HARNESS REPLACEMENT - continued**

**NOTE**

This task is typical for all four pylons.

16.18.3. Removal

- a. **Detach connector P511 (1) from dummy receptacle J511 (2) on pylon stow bracket (3).**

- (1) Pull lanyard (4) to release connector (1).

- b. **Detach connector P512 (5) from dummy receptacle J512 (6) on bracket (3).**

- (1) Pull lanyard (7) to release connector (5).

- c. **Detach connector P513 (8) from dummy receptacle J513 (9) on bracket (3).**

- (1) Pull lanyard (10) to release connector (8).

- d. **Remove wire harness (11) from bracket (3).**

- (1) Remove tie strap from receptacle J256 (12).

- (2) Identify and depin wires (13) and (14) from receptacle J256 (12) (TM 55-1500-323-24).

- (3) Remove two screws (15), washers (16), and clamps (17) from bracket (3).

- e. **Remove clamp (18) from wire harness (19).**

- (1) Remove screw (20), washer (21), and clamp (18) from bracket (22).

- (2) Remove clamp (18) from harness (19).

- f. **Remove clamp (23) from harness (19).**

- (1) Remove screw (24), washer (25), and clamp (23) from bracket (26).

- (2) Remove clamp (23) from harness (19).

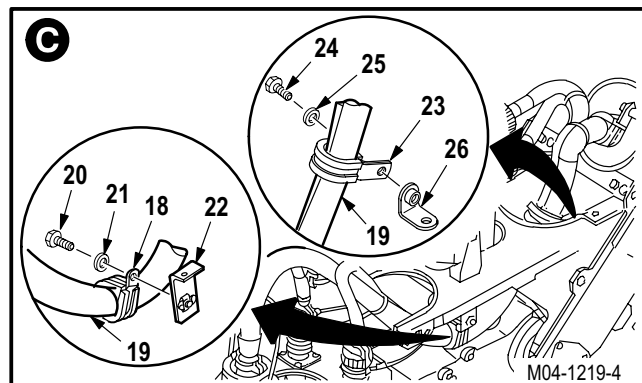
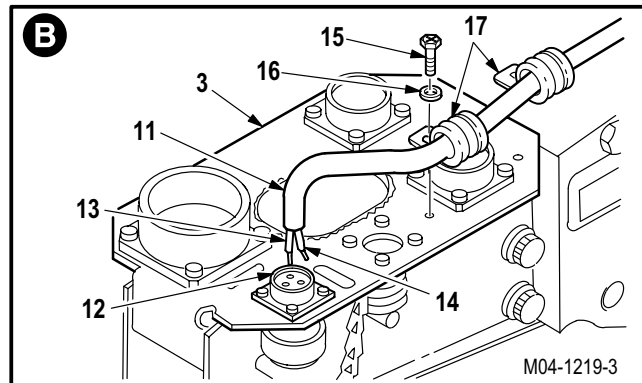
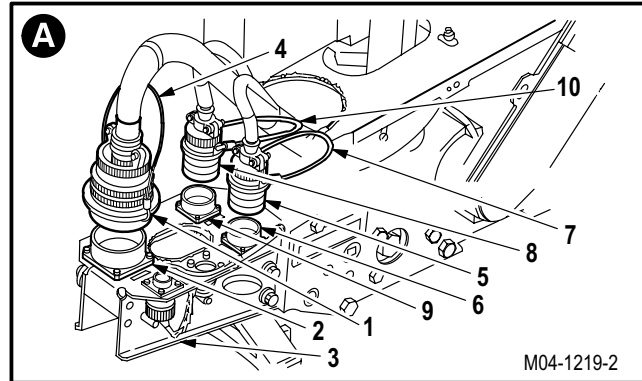

GO TO NEXT PAGE



**16.18. PYLON WIRE HARNESS REPLACEMENT - continued****g. Remove clamp (27) from harness (19).**

- (1) Remove screw (28), washer (29), clamp (27), and spacer (30) from bracket (31).
- (2) Remove clamp (27) from harness (19).

**h. Remove two clamps (32) from harness (19).**

- (1) Remove nut (33), washer (35) from clamp (32) securing P508 harness.
- (2) Hold nut (33). Remove screw (34) and washer (35).
- (3) Remove clamp (32) from harness (19).

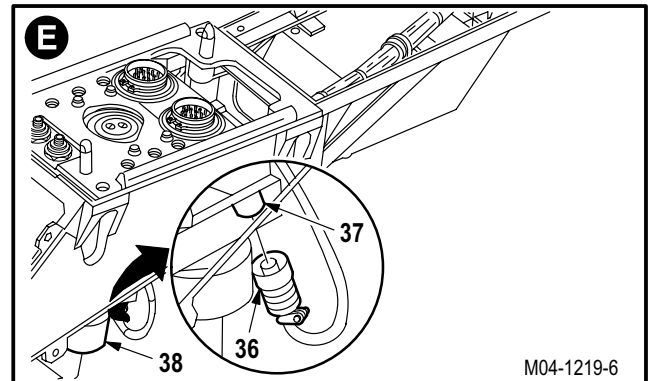
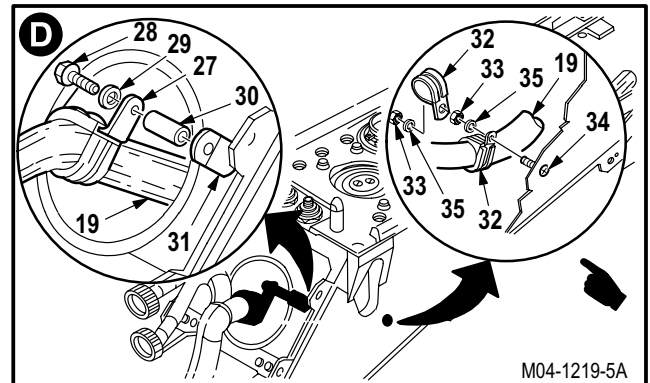
**i. Detach connector P507 (36) from receptacle J507 (37) on pylon actuator (38).**

GO TO NEXT PAGE

16.18. PYLON WIRE HARNESS REPLACEMENT - continued

**WARNING**

Maintain pressure on preloaded spring while removing retaining ring. A spring-loaded mechanism can cause injury to personnel if released in an uncontrolled manner. Always take care while working with the mechanism.

j. Maintain pressure on springs (39) while performing step k.

k. Identify and remove two connectors P505 (40) and P508 (41) from connector plate (42).

- (1) Remove two retaining rings (43), backing washers (44), and springs (39) from plate (42). Use retaining ring pliers.
- (2) Remove plate (42) from top plate (45).
- (3) Remove two screws (46) and washers (47).
- (4) Remove retaining ring (48) from connectors (40) and (41). Use retaining ring pliers.
- (5) Remove connectors (40) and (41) from plate (42).

l. Remove screw (49), washer (50), and clamp (51) from bracket (52).

- (1) Remove clamp (51) from harness (19).

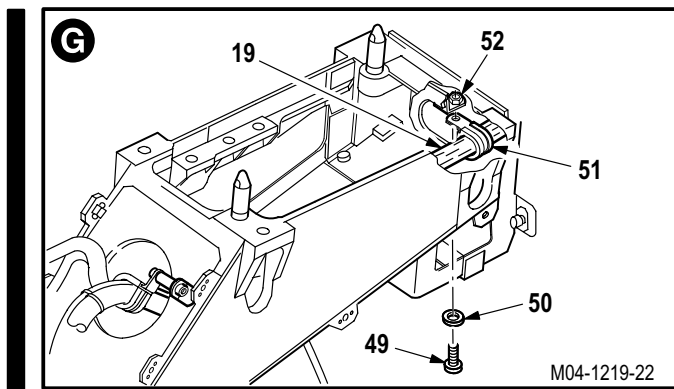
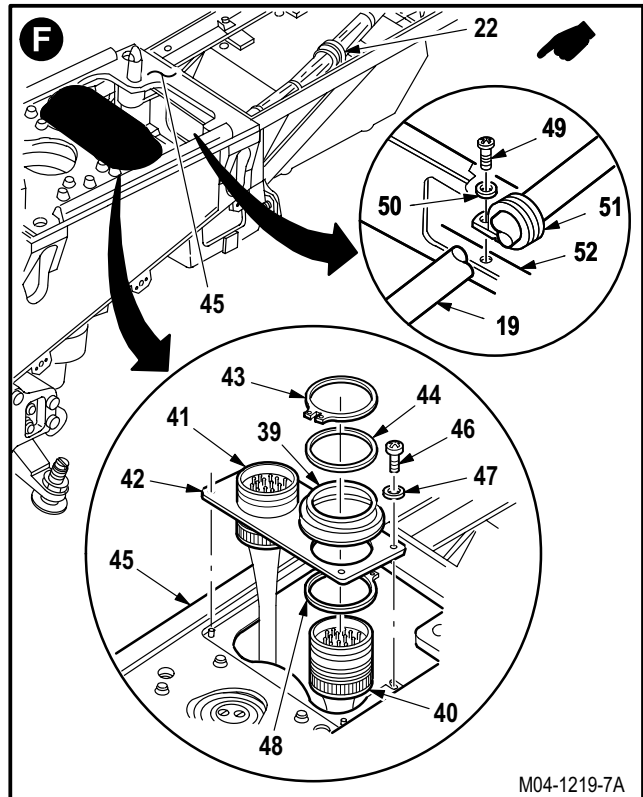

GO TO NEXT PAGE

**16.18. PYLON WIRE HARNESS REPLACEMENT - continued**

m. **Remove two clamps (53), screws (54), washers (55), and nuts (56) from bracket (57).**

- (1) Hold two screws (54). Remove two nuts (56).
- (2) Remove two screws (54), washers (55) and clamps (53) from bracket (57).
- (3) Remove two clamps (53) from harness (19).

n. **Depin six wires (58) from terminal blocks (59) and (60).**

- (1) Identify and depin six wires (58) from terminal blocks (59) and (60) (TM 55-1500-323-24).

o. **Remove harness (19) from pylon (61).**

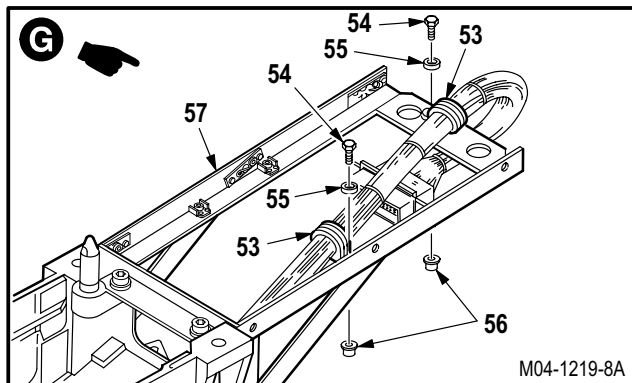

16.18.4. Cleaning

a. **Wipe removed and attaching parts with a clean rag.**

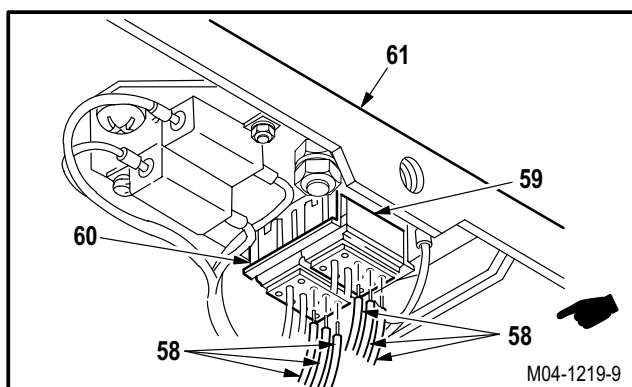

16.18.5. Installation

a. **Install harness (19) on pylon (61).**

b. **Install two clamps (53), screws (54), washers (55), and nuts (56) on bracket (57).**

- (1) Install two clamps (53) on harness (19).
- (2) Aline two clamps (53) with bracket (57).
- (3) Install two screws (54) and through clamps (53), washers (55), and brackets (57).
- (4) Hold two screws (54). Install nuts (56).

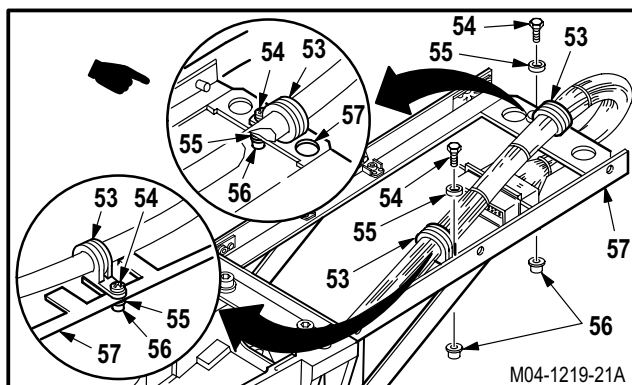

GO TO NEXT PAGE

16.18. PYLON WIRE HARNESS REPLACEMENT - continued

**WARNING**

**Maintain pressure on preloaded spring while installing retaining ring. A spring-loaded mechanism can cause injury to personnel if released in an uncontrolled manner. Always take care while working with the mechanism.**

c. **Compress spring (39) in vise (62).**

- (1) Wrap lockwire around spring (39), three places. Use wire (item 229, App F).
- (2) Evenly space lockwire to hold spring (39) compressed.
- (3) Position and fully compress spring (39) in vise (62).
- (4) Tighten lockwire.
- (5) Remove spring (39) from vise (62).

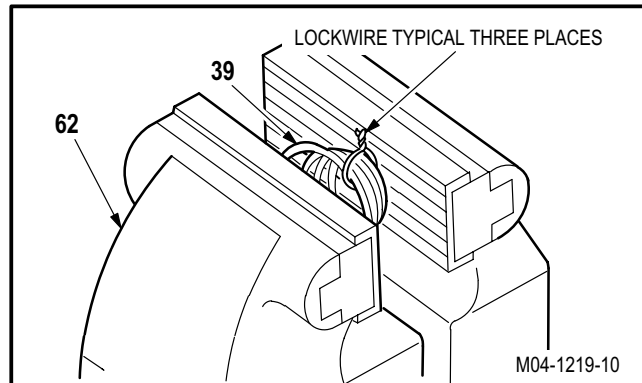

GO TO NEXT PAGE

**16.18. PYLON WIRE HARNESS REPLACEMENT - continued**

**d. Install connector P505 (40) on plate (42).**

- (1) Install ring (48) on connector (40). Use retaining ring pliers.
- (2) Position ring (48) with lugs (63) facing aft.
- (3) Aline keyway (64) on connector (40) with notch (65) in left hole (66) of plate (42).
- (4) Position connector (40) through hole (66) until ring (48) is against bottom of plate (42).
- (5) Install compressed spring (39) and washer (44) on connector (40).
- (6) Position ring (43) with lugs (67) facing forward.
- (7) Install ring (43) on connector (40). Use retaining ring pliers.
- (8) Remove lockwire from spring (39).

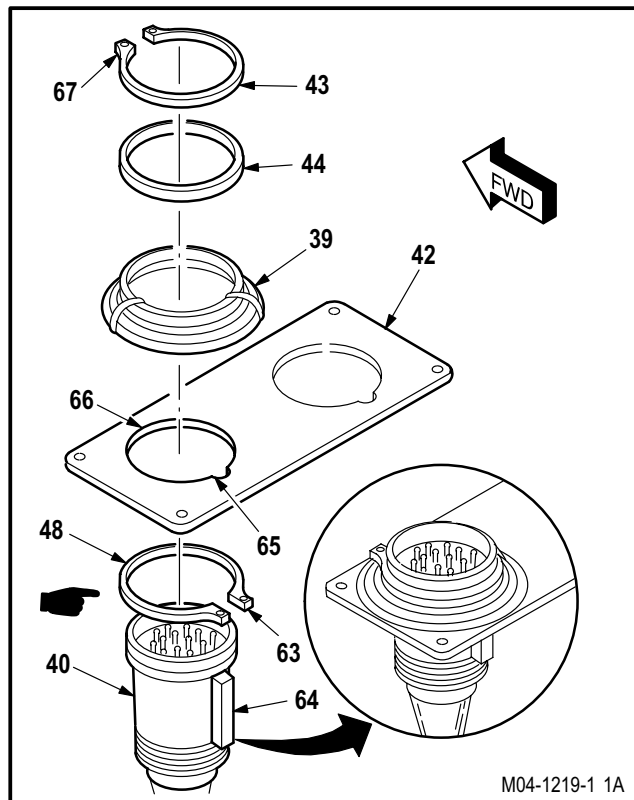

**e. Install connector P508 (41) on plate (42).**

- (1) Install ring (48) on connector (41).
- (2) Position ring (48) with lug (71) facing aft.
- (3) Aline keyway (68) on connector (41) with notch (69) in right hole (70) of plate (42).
- (4) Position connector (41) through hole (70) until ring (48) is against bottom of plate (42).
- (5) Install compressed spring (39) and washer (44) on connector (41).
- (6) Position ring (43) with lug (72) facing forward.
- (7) Install ring (72) on connector (41). Use retaining ring pliers.
- (8) Remove lockwire from spring (39).

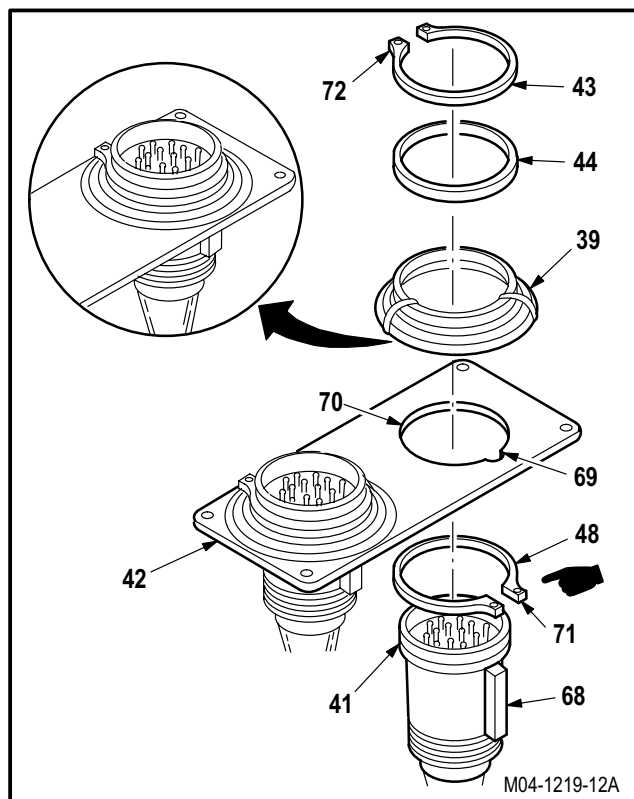

GO TO NEXT PAGE

**16.18. PYLON WIRE HARNESS REPLACEMENT - continued**

**NOTE**

Install connector plate with keyways in aft position. Aline pin with plate.

**f. Install plate (42) on pylon (61).**

- (1) Aline two holes on plate (42) with holes in pylon (61).
- (2) Install two screws (46) through washers (47) and plate (42), and into pylon (61).

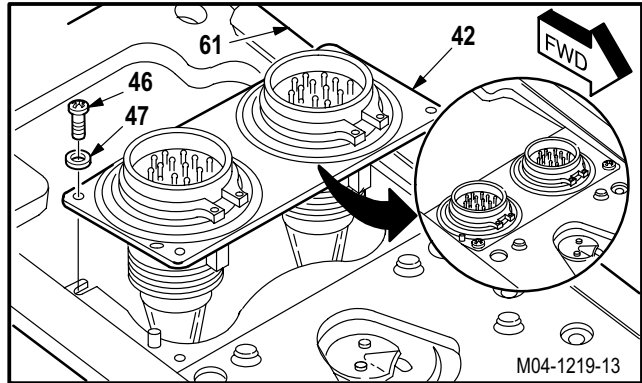

**g. Install clamp (51) on bracket (52).**

- (1) Install clamp (51) on wire harness 19).
- (2) Aline clamp (51) with bracket (52).
- (3) Install screw (49) through washer (50) and clamp (51), and into bracket (52).

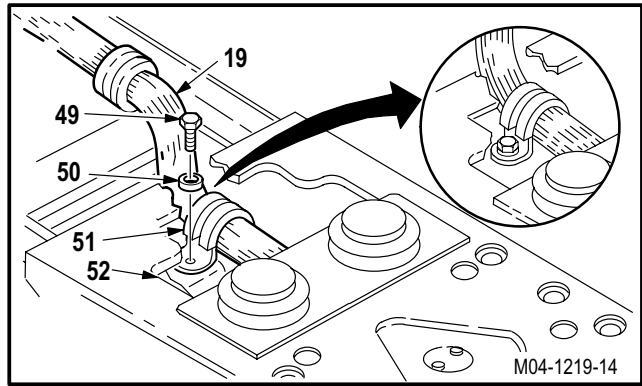

**h. Attach connector P507 (36) to receptacle J507 (37) on pylon actuator (38).**

**i. Install clamp (32) on pylon (61).**

- (1) Install clamp (32) on harness (19).
- (2) Install screw (34) in pylon (61).
- (3) Install clamp (32), washer (35), and nut (33) on screw (34).

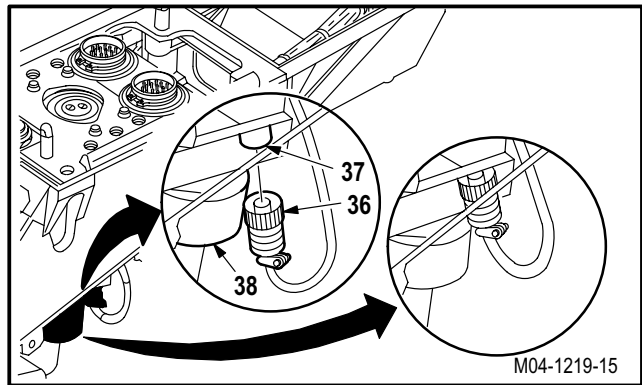

- (4) Hold screw (34). Tighten nut (33).

**j. Install clamp (27) on bracket (31).**

- (1) Install clamp (27) on wire harness (19).
- (2) Install screw (28) through washer (29), clamp (27), spacer (30), and bracket (31).

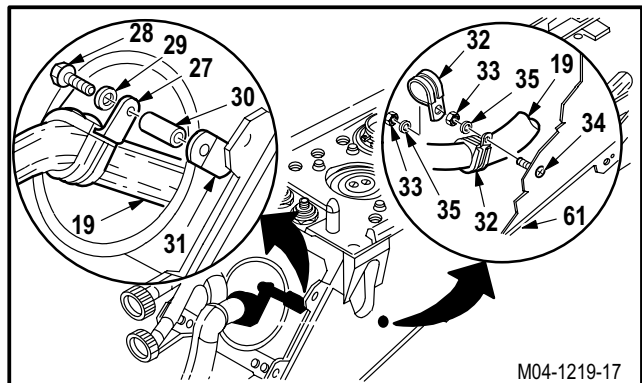

GO TO NEXT PAGE

**16.18. PYLON WIRE HARNESS REPLACEMENT - continued**

**k. Install clamp (23) on bracket (26).**

- (1). Install clamp (23) on wire harness (19).
- (2). Install screw (24) through washer (25), clamp (23), and bracket (26).

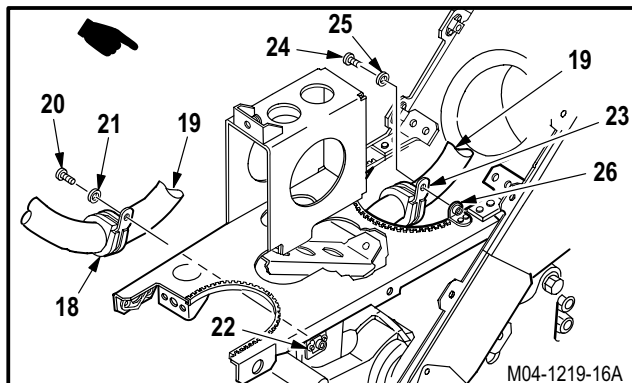

**l. Install clamp (18) on bracket (22).**

- (1). Install clamp (18) on wire harness (19).
- (2). Install screw (20) through washer (21), clamp (18), and bracket (22).

**m. Install wire harness (11) on bracket (3).**

- (1). Pin identified wires (13) and (14) to receptacle J256 (12) (TM 55-1500-323-24).
- (2). Install two clamps (15) on harness (11).
- (3). Install two screws (16) through washers (17) and clamps (15) and into bracket (3).

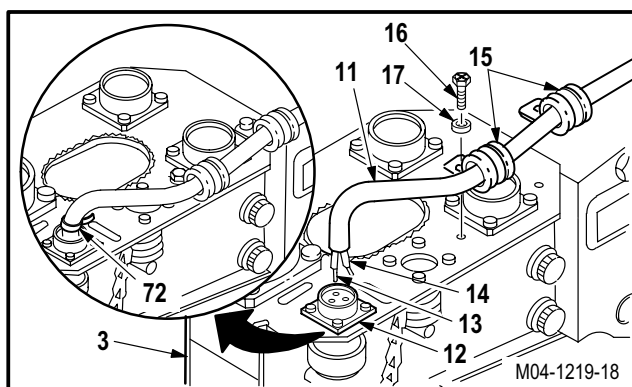

**n. Install tie strap (72) on harness (11). Use strap (item 193, App F).**

**o. Attach connector P513 (8) to receptacle J513 (9) on bracket (3).**

**p. Attach connector P512 (5) to receptacle J512 (6) on bracket (3).**

**q. Attach connector P511 (1) to receptacle J511 (2) on bracket (3).**

**r. Pin six identified wires (58) on terminal blocks (59) and (60) (TM 55-1500-323-24).**

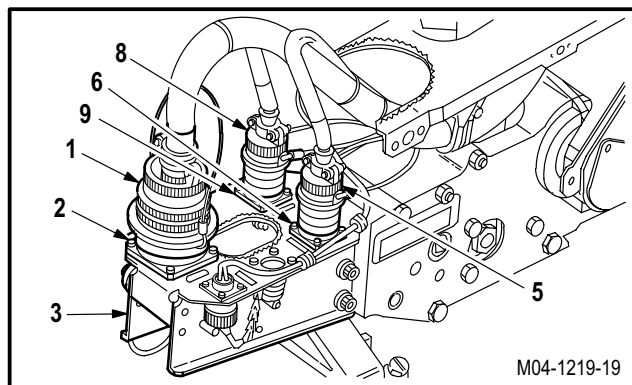

**s. Inspect (QA).**

**t. Install pylon aerial bracket (para 16.14).**

**u. Install pylon actuator and top plate (para 16.9).**

**v. Install pylon controller and controller bracket (para 16.15).**

**w. Install multiplex remote terminal unit type II (TM 9-1230-476-20-1).**

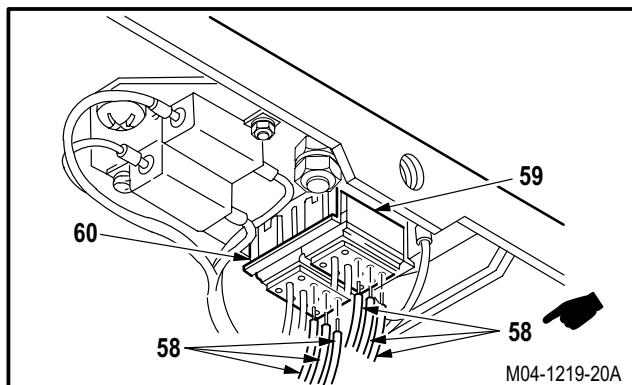

END OF TASK

---

**16.19. PYLON CIRCUIT CARD AND JETTISON WIRE HARNESS REMOVAL/INSTALLATION**

---

16.19.1. Description

This task covers: Removal. Cleaning. Inspection. Repair. Installation.

---

16.19.2. Initial Setup

**Tools:**

- Electrical tool kit (item 378, App H)
- Light duty laboratory apron (item 27, App H)
- Chemical protective gloves (item 154, App H)
- Socket removal tool (item 258, App H)
- Adjustable air filtering respirator (item 262, App H)
- 5-watt electric soldering iron (item 333, App H)

**Materials/Parts:**

- Sealing compound (item 155, App F)
- Solder (item 189, App F)
- Strap (item 193, App F)

**Personnel Required:**

- 68X Armament/Electrical System Repairer
- 68X3F Armament/Electrical System Repairer/  
Technical Inspector

**References:**

TM 55-1500-323-24

**Equipment Conditions:**

<u>Ref</u>	<u>Condition</u>
1.57	Helicopter safed
16.6	Pylon rack ejector removed



**Electrical shock hazard. Turn off and disconnect external and battery electrical power. Tag external battery power switch "Do not apply electrical power." An electrical shock could cause death, serious injury, or burns. If an injury occurs, seek medical aid.**

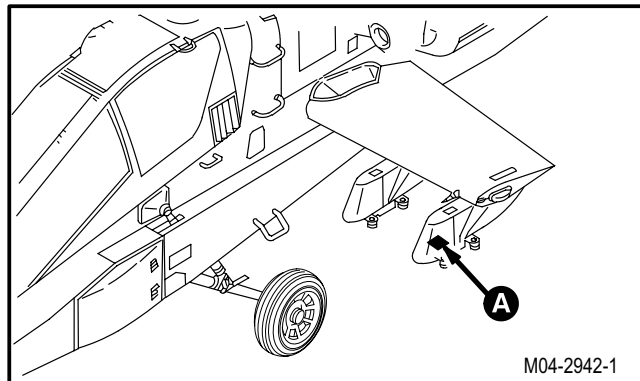

M04-2942-1

GO TO NEXT PAGE



**16.19. PYLON CIRCUIT CARD AND JETTISON WIRE HARNESS REMOVAL/INSTALLATION - continued**

16.19.3. Removal

- a. **Remove and discard two tie straps (1) that attach harness W650 (2) to harness W601 (3).**

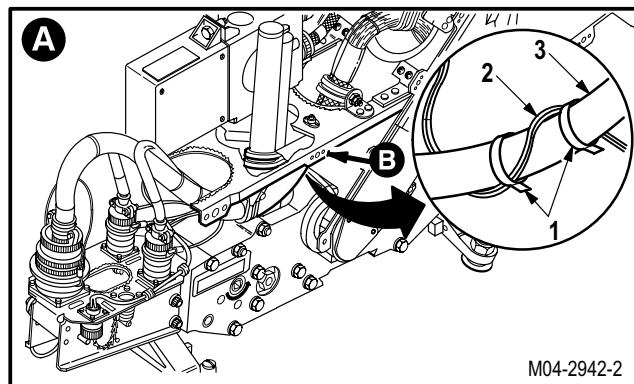

- b. **Remove circuit card (4) from underside of station director mounting bracket (5).**

- (1) Identify and depin three wires (6) from terminal block (7).
- (2) Identify and depin three wires (8) from terminal block (9).
- (3) Remove two screws (10) and washers (11).
- (4) Remove card (4) from bracket (5).

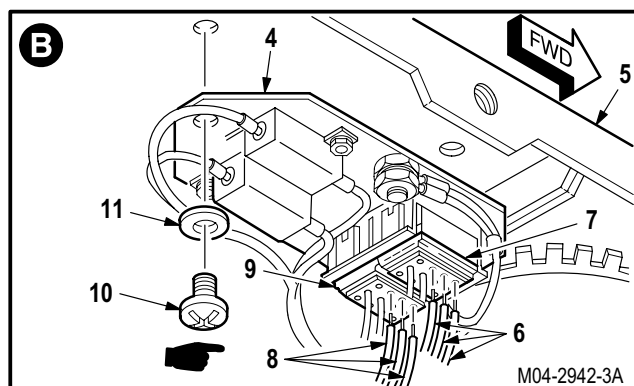

16.19.4. Cleaning

- a. **Wipe removed and attaching parts with a clean rag.**

16.19.5. Inspection

- a. **Check circuit card assembly and wire harness W650 for frayed or broken wires and damaged connections (TM 55-1500-323-24).**

GO TO NEXT PAGE

16.19. PYLON CIRCUIT CARD AND JETTISON WIRE HARNESS REMOVAL/INSTALLATION - continued

16.19.6. Repair



**WARNING**

Soldering iron can cause severe burns to personnel and start fires. Observe all safety precautions when using soldering iron. If injury occurs, seek medical aid.

a. Repair harness (2) by replacing insulator (12) and firing contact pin (13).

- (1) Remove sealing compound from pin (13) (TM 55-1500-323-24).
- (2) Desolder wires (14) and (15) from pin (13). Use soldering iron (TM 55-1500-323-24).
- (3) Solder wires (14) and (15) to new pin (13). Use solder (item 189, App F) and soldering iron (TM 55-1500-323-24).
- (4) Install new insulator (12) on pin (13).

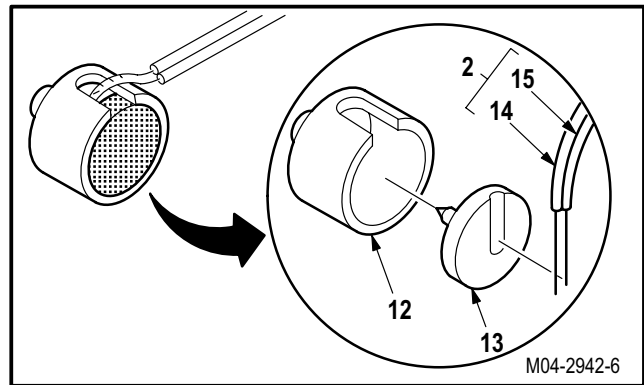

**NOTE**

The pin needs to be held firmly against the face of the insulator as the sealing compound is applied and the sealing compound must be allowed to cure.

- (5) Apply sealing compound to pin (13). Use sealing compound (item 155, App F).
- (6) Allow sealing compound to cure.

**NOTE**

This repair is typical for resistors R1 or R2 replacement.

b. Repair card (4) by replacing resistor (16).

- (1) Identify and desolder wires (17) and (18) on ends of resistor (16). Use soldering iron (TM 55-1500-323-24).
- (2) Remove two nuts (19) and washers (20) from resistor (16).

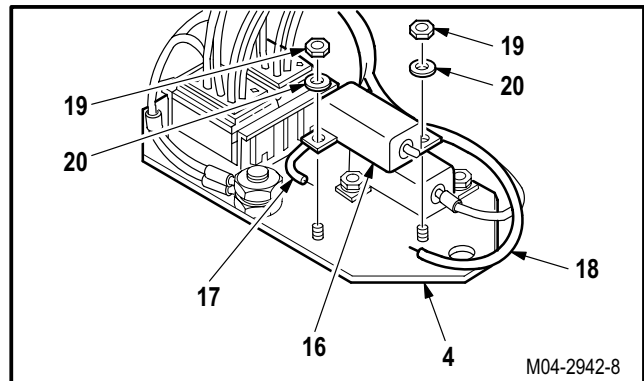

GO TO NEXT PAGE

**16.19. PYLON CIRCUIT CARD AND JETTISON WIRE HARNESS REMOVAL/INSTALLATION - continued**

- (3) Remove and discard resistor (16) from card (4).
- (4) Install new resistor (16) on card (4).
- (5) Install two nuts (19) and two washers (20) on card (4).
- (6) Solder wires (17) and (18) to resistor (16). Use solder (item 189, App F) and soldering iron (TM 55-1500-323-24).

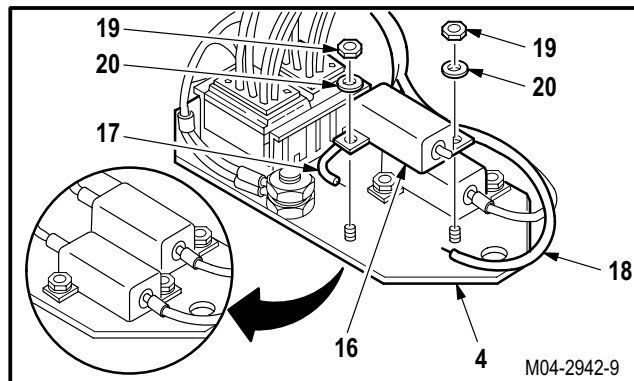

**NOTE**

This repair is typical for electrical contact module TB1 or TB2.

**c. Repair card (4) by replacing terminal block module (21).**

- (1) Identify and remove wires (22) from module (21).
- (2) Remove and discard module (21) from mounting bracket (23). Use socket removal tool.
- (3) Install new module (21) on mounting bracket (23).
- (4) Install identified wires (22) to module (21).

**d. Inspect (QA).**

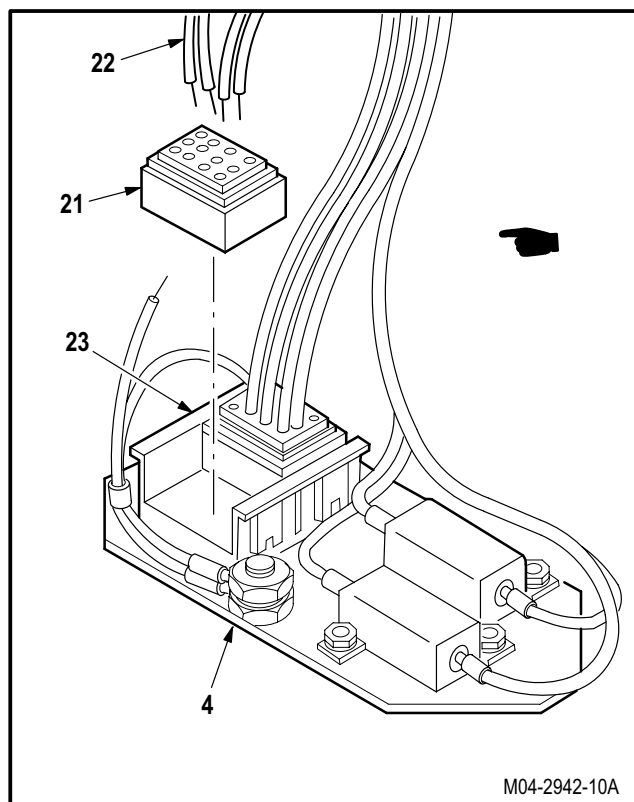

GO TO NEXT PAGE

---

**16.19. PYLON CIRCUIT CARD AND JETTISON WIRE HARNESS REMOVAL/INSTALLATION - continued**

---

16.19.7. Installation

a. **Install card (4) on bottom of bracket (5).**

- (1) Install two screws (10) and washers (11).
- (2) Pin three identified wires (6) to terminal block (7) (TM 55-1500-323-24).
- (3) Pin three identified wires (8) to terminal block (9) (TM 55-1500-323-24).

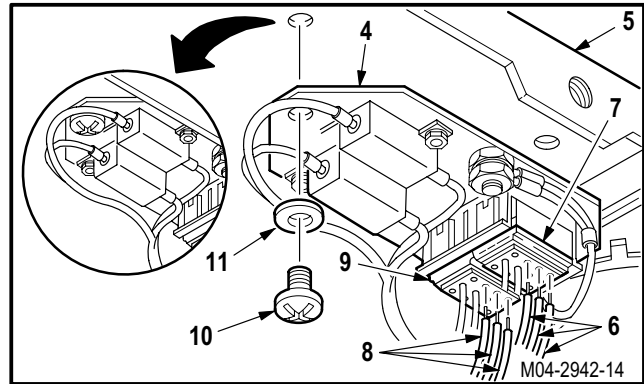

b. **Secure harness W650 (2) to harness W601 (3) with two tie straps (1).** Use strap (item 193, App F).

c. **Install pylon rack ejector** (para 16.6).

d. **Inspect (QA).**

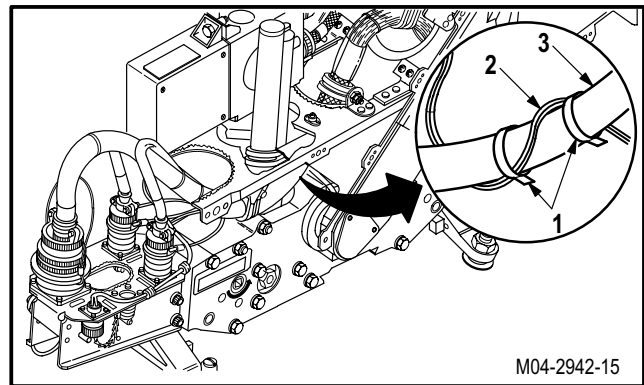

END OF TASK

## 16.20. PYLON FRAME STRAIGHT PIN REPLACEMENT

### 16.20.1. Description

This task covers: Removal. Cleaning. Inspection. Installation.

### 16.20.2. Initial Setup

#### Tools:

- Electrical tool kit (item 378, App H)
- 30 - 150 inch-pound 3/8-inch drive click type torque wrench (item 441, App H)
- 5X & 12X monocular magnifier (item 206, App H)

#### Personnel Required:

- 68X Armament/Electrical System Repairer
- 68X3F Armament/Electrical System Repairer/  
Technical Inspector

#### Equipment Conditions:

<u>Ref</u>	<u>Condition</u>
1.57	Helicopter safed
16.9	Pylon actuator and top plate removed
16.15	Pylon controller and controller bracket removed

### 16.20.3. Removal

#### a. Remove straight pin (1) from pylon frame (2).

- (1) Hold pin (1). Remove bolt (3) and washer (4).
- (2) Remove and discard pin (1).

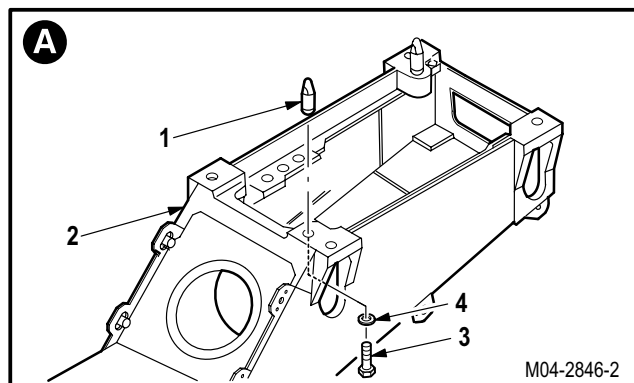
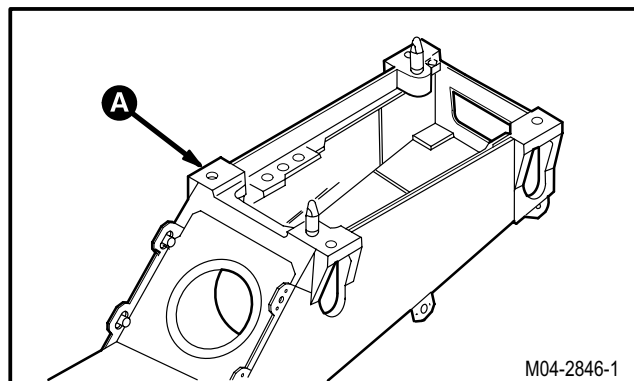

GO TO NEXT PAGE

**16.20. PYLON FRAME STRAIGHT PIN REPLACEMENT - continued**

16.20.4. Cleaning

- a. **Wipe pin mounting area with a clean rag.**

16.20.5. Inspection

- a. **Check pin mounting area for cracks.** None allowed. **Use magnifier.** If cracks are suspected, perform nondestructive inspection (TM 1-1520-264-23). Replace pylon frame if cracked (para 16.22).

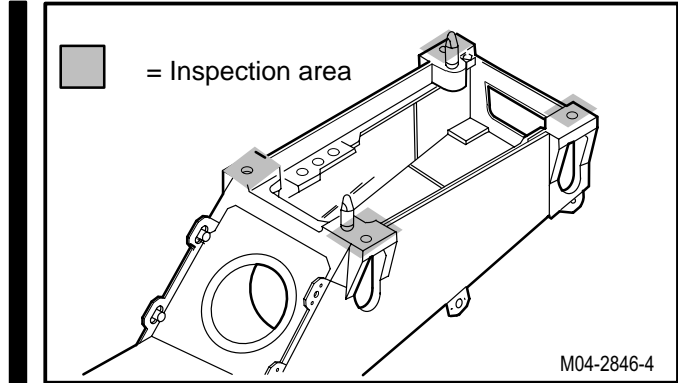

16.20.6. Installation

- a. **Install pin (1) in pylon frame (2).** Torque bolt (3) to **70 INCH-POUNDS**.

- (1) Install new pin (1) in hole.
- (2) Install bolt (3) and washer (4).
- (3) Torque bolt (3) to **70 INCH-POUNDS**. Use torque wrench.

- b. **Inspect (QA).**
- c. **Install pylon actuator and top plate** (para 16.9).
- d. **Install pylon controller and controller bracket** (para 16.15).

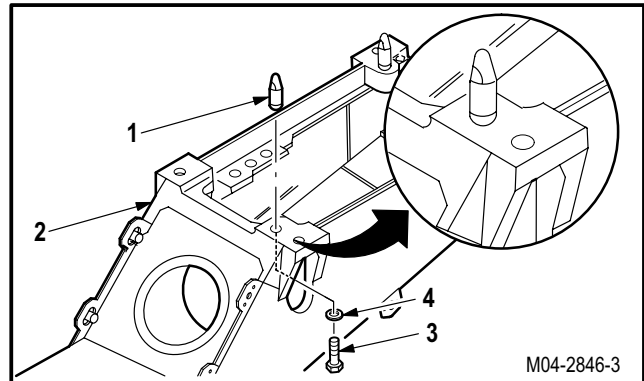

END OF TASK

---

**16.21. PYLON SWAY BRACE REPLACEMENT (AVIM)**

---

**16.21.1. Description**

This task covers: Removal. Cleaning. Inspection. Installation.

---

**16.21.2. Initial Setup****Tools:**

Electrical tool kit (item 378, App H)  
0 - 600 inch-pound 3/8-inch drive dial indicator torque  
wrench (item 447, App H)

**Equipment Conditions:**

<u>Ref</u>	<u>Condition</u>
1.57	Helicopter safed

**Personnel Required:**

68X Armament/Electrical System Repairer  
68X3F Armament/Electrical System Repairer/  
Technical Inspector

---

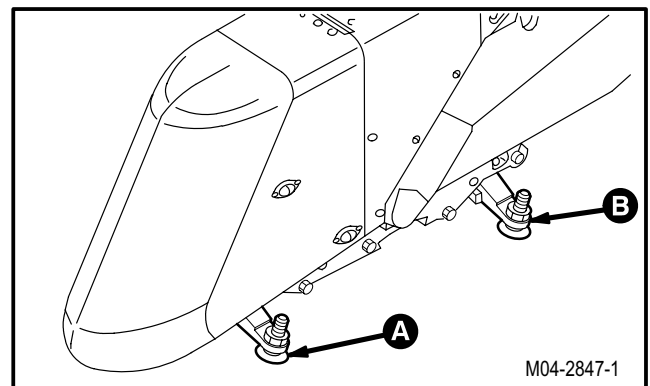

GO TO NEXT PAGE

---

**16.21. PYLON SWAY BRACE REPLACEMENT (AVIM) - continued**

---

16.21.3. Removal

a. **Remove forward sway brace (1) from pylon rack (2).**

- (1) Remove two nuts (3), bolts (4), and four washers (5).
- (2) Remove and discard brace (1) from rack (2).

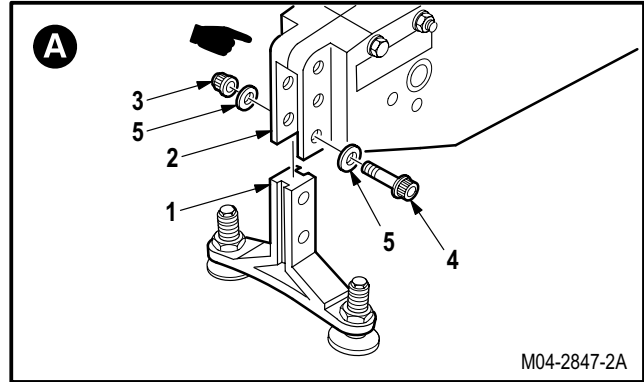

b. **Remove aft sway brace (6) from rack (2).**

- (1) Remove two nuts (7), bolts (8), and four washers (9).
- (2) Remove and discard brace (6) from rack (2).

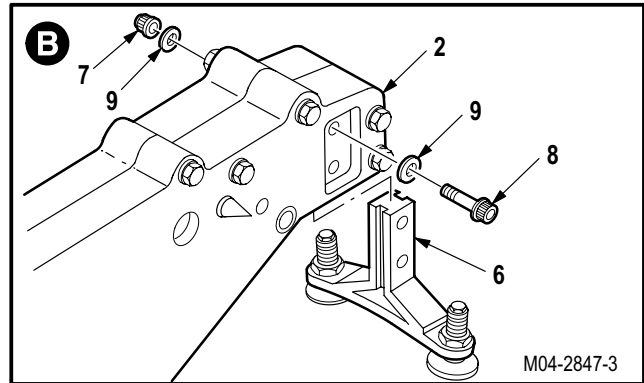

16.21.4. Cleaning

a. **Wipe sway brace with a clean rag.**

16.21.5. Inspection

- a. **Check sway brace for corrosion** (para 1.49).
- b. **Check sway brace for cracks.** None allowed.

GO TO NEXT PAGE



**16.21. PYLON SWAY BRACE REPLACEMENT (AVIM) - continued**

16.21.6. Installation

a. **Install brace (6) on rack (2).** Torque two nuts (7) to **225 INCH-POUNDS**.

- (1) Position brace (6) on aft end of rack (2) with holder (10) facing down.
- (2) Insert two bolts (8) through washers (9) and bolt holes (11).
- (3) Install two washers (9) and nuts (7) on bolts (8).
- (4) Hold bolts (8). Torque nuts (7) to **225 INCH-POUNDS**. Use torque wrench.

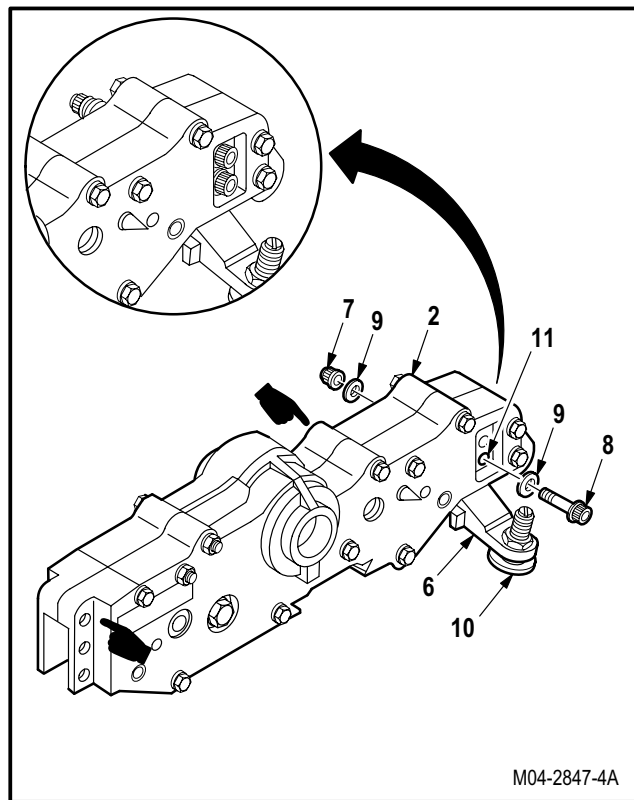

b. **Install brace (1) on rack (2).** Torque nut (3) to **225 INCH-POUNDS**.

- (1) Position brace (1) on forward end of rack (2) with holder (12) facing down.
- (2) Insert two bolts (4) through washers (5) and bolt holes (13).
- (3) Install two washers (5) and nuts (3) on bolts (4).
- (4) Hold two bolts (4). Torque nuts (3) to **225 INCH-POUNDS**. Use torque wrench.

c. **Inspect (QA).**

d. **Install pylon stow bracket** (para 16.17).

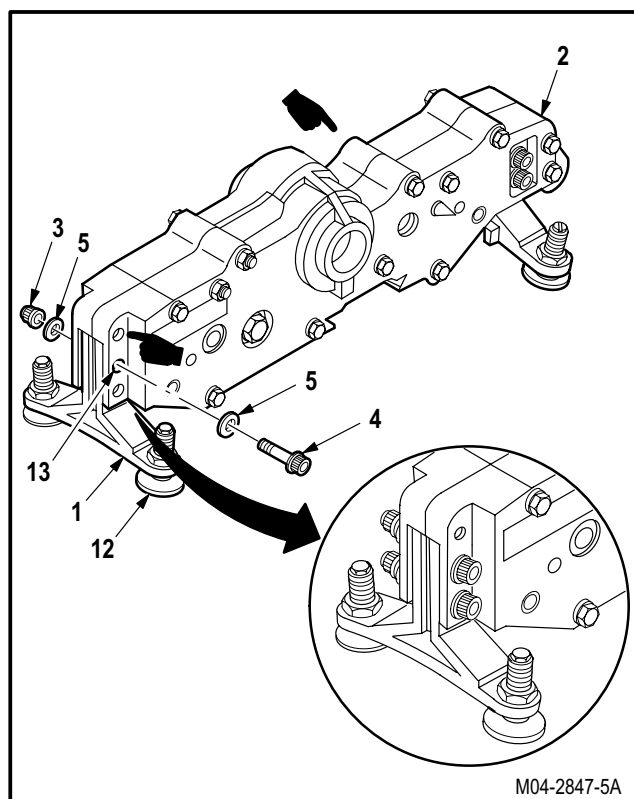

END OF TASK

---

## 16.22. PYLON FRAME REMOVAL/INSTALLATION

---

### 16.22.1. Description

This task covers: Removal. Cleaning. Inspection. Repair. Installation.

---

### 16.22.2. Initial Setup

#### Tools:

Electrical tool kit (item 378, App H)  
5X & 12X monocular magnifier (item 206, App H)

#### References:

TM 1-1500-204-23

#### Equipment Conditions:

<u>Ref</u>	<u>Condition</u>
1.57	Helicopter safed
16.4	Pylon rack removed
16.14	Pylon aerial bracket removed
16.15	Pylon controller and controller bracket removed
16.16	Pylon MRTU bracket removed
16.18	Pylon wire harness removed

#### Personnel Required:

68X Armament/Electrical System Repairer  
68X3F Armament/Electrical System Repairer/  
Technical Inspector

---

### 16.22.3. Removal

- a. **Detach connectors.** Remove wire harness clamps as required (para 16.18).

### 16.22.4. Cleaning

- a. **Wipe pylon frame with a clean rag.**

### 16.22.5. Inspection

- a. **Check pylon frame for cracks** (para 16.1).
- b. **Check pylon frame for damaged inserts, pylon frame mounting bushings, and receptacles** (para 16.1).
- c. **Check pylon frame for corrosion** (para 1.49).

GO TO NEXT PAGE

---

**16.22. PYLON FRAME REMOVAL/INSTALLATION - continued**

---

16.22.6. Repair

- a. **Damaged inserts (2), rivetless nutplates (3), riveted nutplates (7), and receptacles (4) shall be replaced** (TM 1-1500-204-23).
- b. **Pylon frame mounting bushings (6) with an ID greater than 1.438 INCHES are not acceptable.**
- c. **Repair frame (1) by removing corrosion** (para 1.49).

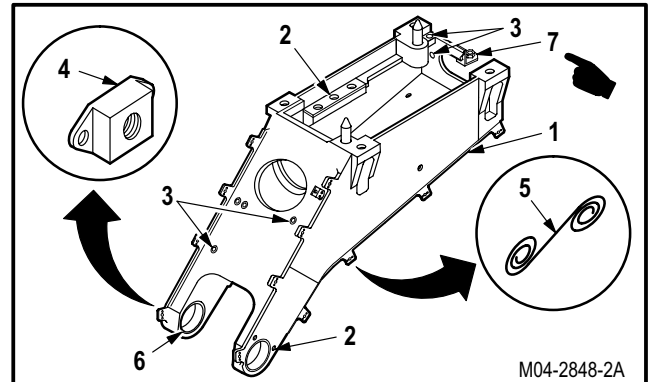
16.22.7. Installation

- a. **Install pylon wire harness** (para 16.18).
- b. **Install MRTU bracket** (para 16.16).
- c. **Install pylon controller and controller bracket** (para 16.15).
- d. **Install aerial bracket assembly** (para 16.14).
- e. **Install pylon rack** (para 16.4).
- f. **Inspect (QA).**

END OF TASK

**16.23. PYLON TELESCOPING STRUT AND SUPPORT BRACKET REMOVAL/INSTALLATION**

16.23.1. Description

This task covers: Removal. Cleaning. Inspection. Repair. Installation.

16.23.2. Initial Setup

**Tools:**

Airframe repairman's tool kit (item 377, App H)  
 Electrical tool kit (item 378, App H)

**References:**

TM 1-1500-204-23  
 TM 9-1090-208-23-1

**Equipment Conditions:**

**Personnel Required:**

68G Aircraft Structural Repairer  
 68X Armament/Electrical System Repairer  
 One person to assist  
 68X3F Armament/Electrical System Repairer/  
 Technical Inspector

<u>Ref</u>	<u>Condition</u>
1.57	Helicopter safed
2.2	Pylon fairing P1 removed
16.3	Pylon rack ejector impulse cartridge removed
TM 9-1090-208-23-1	Station director removed

16.23.3. Removal

a. **Remove telescoping strut (1) from pylon (2).**

- (1) With one person supporting nose fairing (3), second person remove two bolts (4) and washers (5) from brackets (6) and (7).
- (2) Remove strut (1).

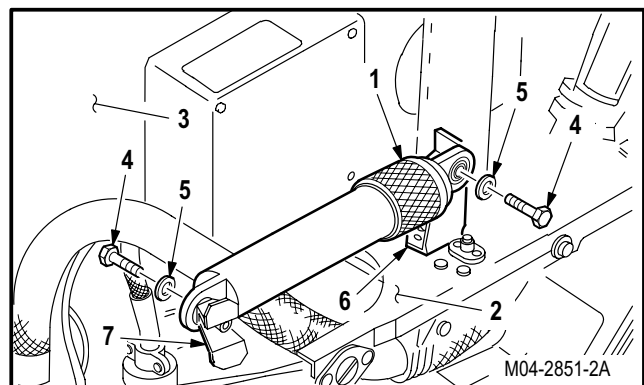
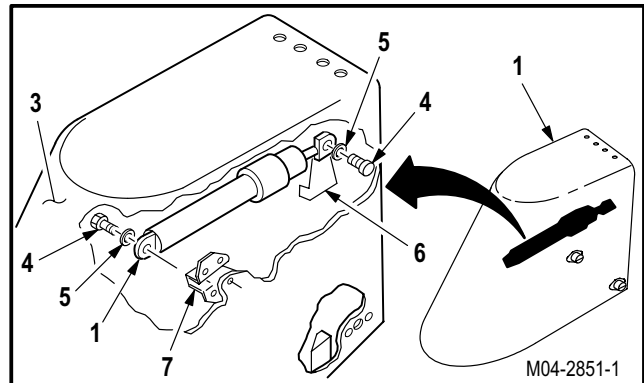

GO TO NEXT PAGE

---

**16.23. PYLON TELESCOPING STRUT AND SUPPORT BRACKET REMOVAL/INSTALLATION - continued**

---

**NOTE**

Perform step b if strut support bracket is to be replaced.

b. **Remove and discard bracket (6).**

(1) Remove three rivets (8) (TM 1-1500-204-23).

16.23.4. Cleaning

a. **Wipe telescoping strut and support bracket mounting area with a clean rag.**

16.23.5. Inspection

a. **Check station director mounting bracket for cracks and damaged nutplates (para 16.1).**

b. **Check strut support bracket for cracks and damaged insert. None allowed.**

c. **Check mounting bracket and support bracket for corrosion (para 1.49).**

16.23.6. Repair

a. **Repair brackets (6) and (9) by repairing cracks and replacing nutplate (10) (TM 1-1500-204-23).**

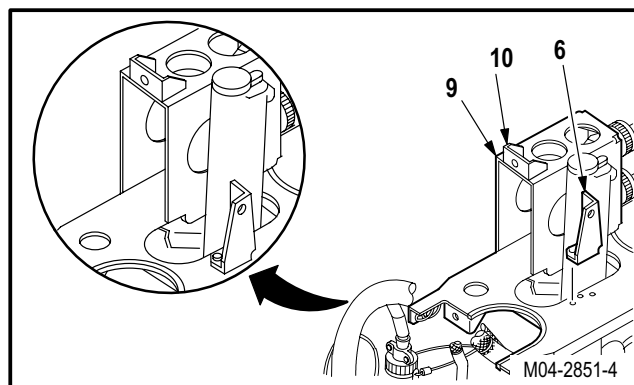
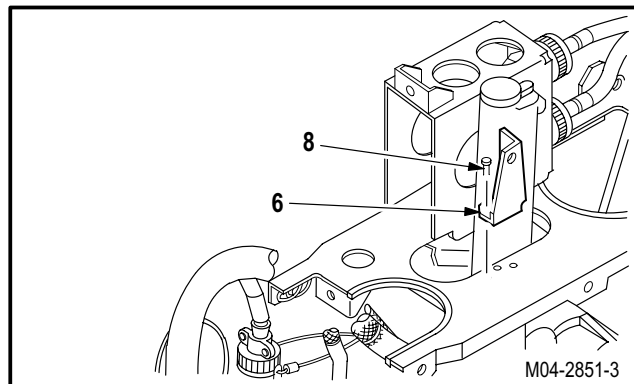

GO TO NEXT PAGE

**16.23. PYLON TELESCOPING STRUT AND SUPPORT BRACKET REMOVAL/INSTALLATION - continued**

16.23.7. Installation

a. **Install new bracket (6) on bracket (9).**

(1) Install three rivets (8) (TM 1-1500-204-23).

b. **Install station director (TM 9-1090-208-23-1).**

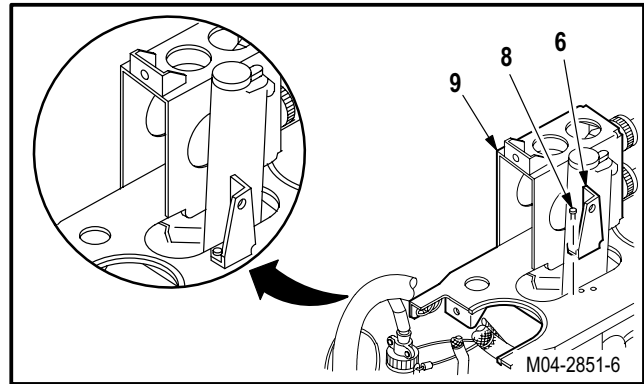

c. **Install strut (1) on pylon (2).**

(1) With one person supporting fairing (3), second person align strut (1) with brackets (6) and (7).

(2) Install two bolts (4) and washers (5).

d. **Inspect (QA).**

e. **Install pylon fairing P1 (para 2.2).**

f. **Install pylon rack ejector impulse cartridge (para 16.3).**

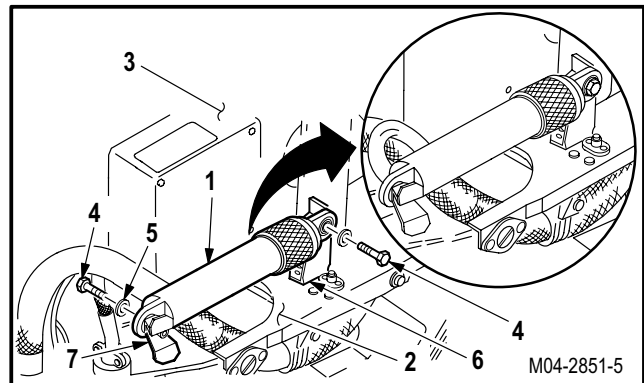

END OF TASK

---

**16.24. PYLON TOP CONNECTOR PLATE REMOVAL/INSTALLATION**

---

16.24.1. Description

This task covers: Removal. Cleaning. Inspection. Repair. Installation.

---

16.24.2. Initial Setup**Tools:**

Electrical tool kit (item 378, App H)  
Retaining ring pliers (item 227, App H)

**Personnel Required:**

68X Armament/Electrical System Repairer  
68X3F Armament/Electrical System Repairer/  
Technical Inspector

**References:**

TM 1-1500-204-23

**Equipment Conditions:**

<u>Ref</u>	<u>Condition</u>
1.57	Helicopter safed
16.2	Pylon removed

**Materials/Parts:**

Wire (item 229, App F)

16.24.3. Removal

- a. **Remove connector plate (1) from pylon frame (2).**

(1) Remove two screws (3) and washers (4).

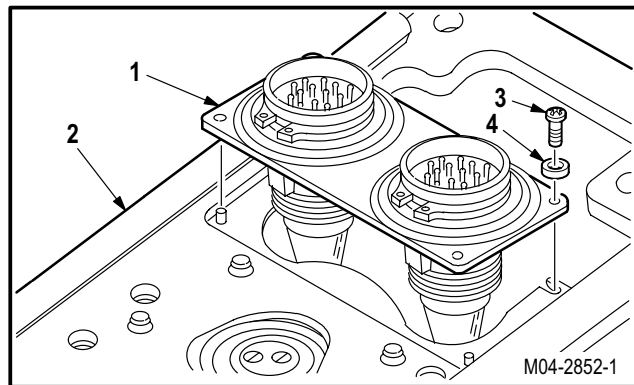

GO TO NEXT PAGE

16.24. PYLON TOP CONNECTOR PLATE REMOVAL/INSTALLATION - continued

**WARNING**

**Maintain pressure on preloaded spring while removing retaining ring. A spring-loaded mechanism can cause injury to personnel if released in an uncontrolled manner. Always take care while working with the mechanism.**

**b. Remove two connectors P505 (6) and P508 (7) from plate (1).**

- (1) Maintain pressure on springs (5). Use wire (item 229, App F).
- (2) Remove retaining ring (8), backing washer (9), spring (5), and retainer (10). Use retaining ring pliers.

**c. Remove connector plate (1).**

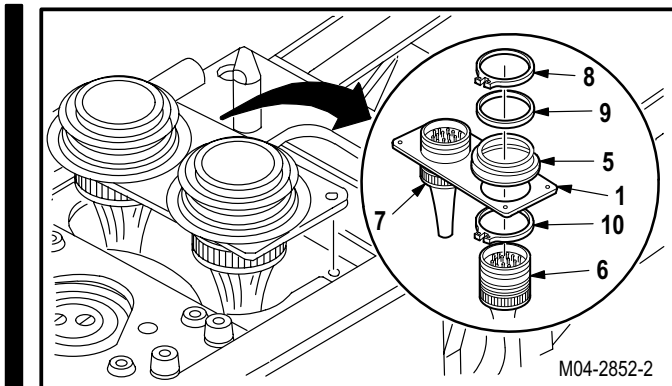

16.24.4. Cleaning

- a. **Wipe plate mounting area with a clean rag.**

16.24.5. Inspection

- a. **Check connector plate for cracks.** None allowed.
- b. **Check connector plate for corrosion** (para 1.49).
- c. **Check connector plate spacers for excessive wear.** Inner diameter not to exceed **0.220 INCH**.
- d. **Check connector plate mounting holes for excessive wear.** Inner diameter not to exceed **0.1346 INCH**.

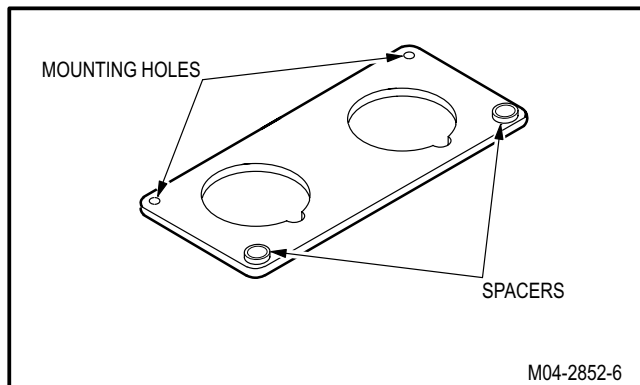

16.24.6. Repair

- a. **Repair connector plate by repairing cracks** (TM 1-1500-204-23).
- b. **Repair connector plate by removing corrosion** (para 1.49).

GO TO NEXT PAGE



---

**16.24. PYLON TOP CONNECTOR PLATE REMOVAL/INSTALLATION - continued**

---

16.24.7. Installation

**WARNING**

**Maintain pressure on preloaded spring while installing retaining ring. A spring-loaded mechanism can cause injury to personnel if released in an uncontrolled manner. Always take care while working with the mechanism.**

a. **Compress spring (5) in vise (11).**

- (1) Wrap lockwire around spring (5) at three places. Use wire (item 229, App F).
- (2) Evenly space lockwire to hold spring (5) compressed.
- (3) Position and fully compress spring (5) in vise (11).
- (4) Tighten lockwire.
- (5) Remove spring (5) from vise (11).

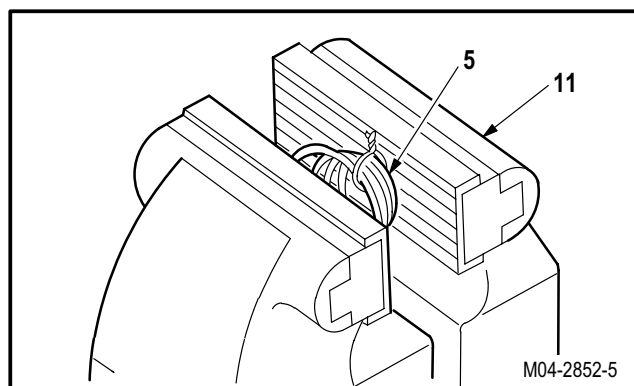
b. **Install two connectors P505 (6) and P508 (7) in plate (1).**

- (1) Aline keyway (12). Install retainer (10).
- (2) Install spring (5), backing washer (9), and ring (8). Use retaining ring pliers.

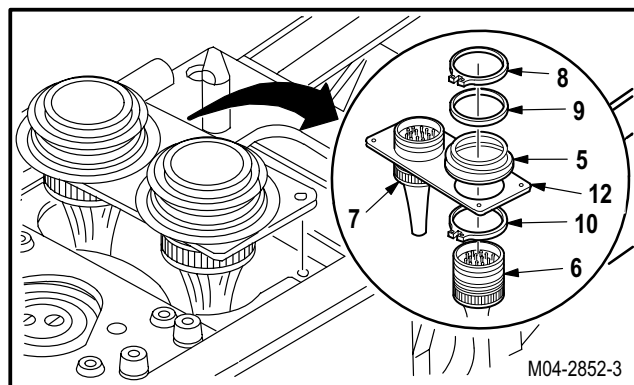
c. **Remove lockwire.**d. **Install plate (1) in frame (2).**

- (1) Aline plate (1) with frame (2). Install two screws (3) and washers (4).

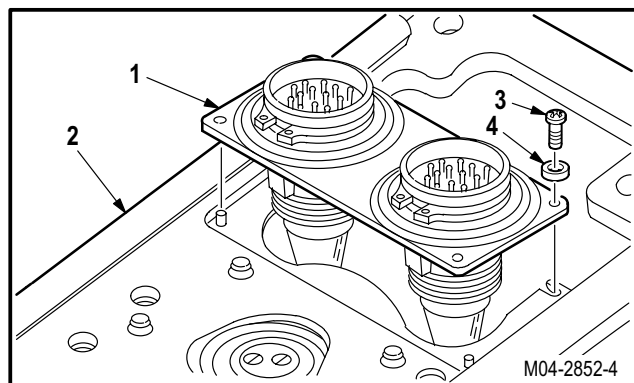
e. **Inspect (QA).**f. **Install pylon** (para 16.2).

END OF TASK

---

## 16.25. PYLON RACK BUSHING REPLACEMENT

---

### 16.25.1. Description

This task covers: Removal. Cleaning. Inspection. Installation.

---

### 16.25.2. Initial Setup

#### **Tools:**

Electrical tool kit (item 378, App H)  
0 - 600 inch-pound 3/8-inch drive dial indicator torque wrench (item 447, App H)

#### **References:**

TM 1-1520-238-T  
TM 9-1230-476-20-1

#### **Materials/Parts:**

Cotter pin

#### **Equipment Conditions:**

#### **Personnel Required:**

68X Armament/Electrical System Repairer  
68X3F Armament/Electrical System Repairer/  
Technical Inspector

#### Ref

#### Condition

1.57 Helicopter safed  
16.3 Pylon rack ejector impulse cartridge removed

---

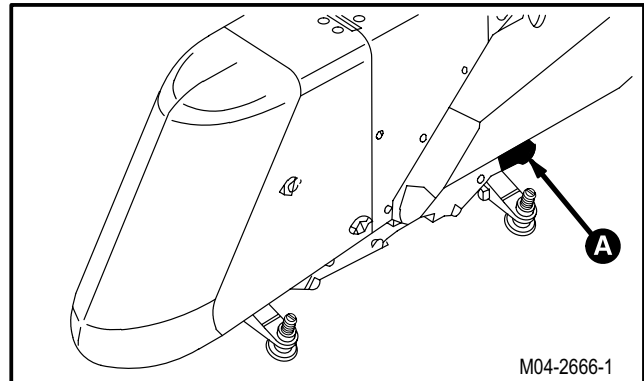

GO TO NEXT PAGE

**16.25. PYLON RACK BUSHING REPLACEMENT - continued**

16.25.3. Removal

a. **Remove pylon rack bushing (1) from yoke (2).**

- (1) Remove and discard cotter pin (3).
- (2) Hold bolt (4). Remove nut (5) and washer (6).
- (3) Remove bolt (4) and rod end (7) from yoke (2).
- (4) Remove bushing (1) from yoke (2) by tapping lightly. Discard bushing (1).

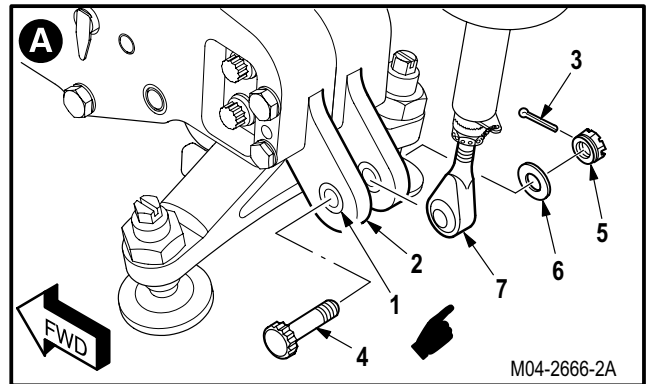

16.25.4. Cleaning

a. **Wipe actuator rod end and yoke with a clean rag.**

16.25.5. Inspection

- a. **Check actuator rod end and yoke for cracks.** None allowed.
- b. **Check actuator rod end and yoke for corrosion** (para 1.49).

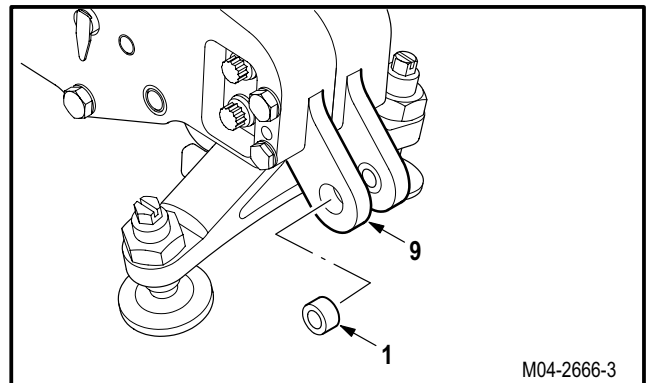

16.25.6. Installation

a. **Install new bushing (1) in yoke (2).**

- (1) Seat bushing (1) by tapping lightly.

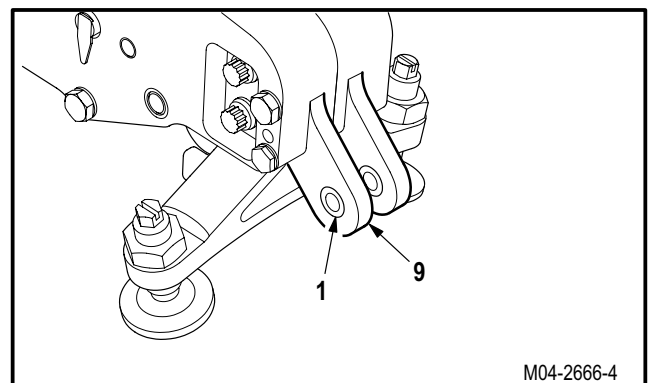

GO TO NEXT PAGE

**16.25. PYLON RACK BUSHING REPLACEMENT - continued**

b. **Install rod end (7) in yoke (2).** Torque nut (5) **285 to 500 INCH POUNDS.**

- (1) Aline rod end (7) with yoke (2).
- (2) Install bolt (4) through yoke (2), rod end (7), washer (6), and nut (5).
- (3) Hold bolt (4). Torque nut (5) to **285 INCH-POUNDS.** Use torque wrench.
- (4) Increase torque to aline cotter pin holes, but do not exceed **500 INCH-POUNDS.**
- (5) Install new cotter pin (3).

c. **Inspect (QA).**

d. **Install pylon rack ejector impulse cartridge** (para 16.3).

e. **Perform external stores elevation control maintenance operational check** (TM 1-1520-238-T).

f. **Perform pylon boresighting** (TM 9-1230-476-20-1).

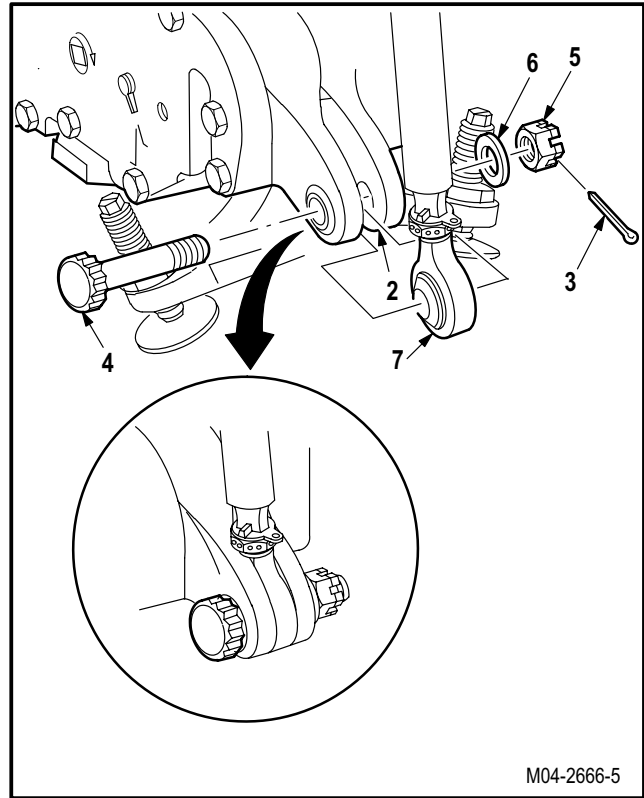

M04-2666-5

END OF TASK

**16.26. PYLON FAIRING AFT BUMPER REPLACEMENT**

16.26.1. Description

This task covers: Removal. Cleaning. Inspection. Installation.

16.26.2. Initial Setup

**Tools:**

- Electrical tool kit (item 378, App H)
- Light duty laboratory apron (item 27, App H)
- Chemical protective gloves (item 154, App H)
- Adjustable air filtering respirator (item 262, App H)

**Personnel Required:**

- 68X Armament/Electrical System Repairer
- 68X3F Armament/Electrical System Repairer/  
Technical Inspector

**References:**

TM 1-1500-204-23

**Materials/Parts:**

- Rivets (28)
- Adhesive (item 18, App F)
- Brush (item 34, App F)

**Equipment Conditions:**

<u>Ref</u>	<u>Condition</u>
1.57	Helicopter safed
2.2	Pylon fairing P3 removed

**NOTE**

This task is typical for all four pylons.

16.26.3. Removal

a. **Remove bumper (1) from fairing (2).**

- (1) Remove and discard 28 rivets (3) (TM 1-1500-204-23).
- (2) Remove 56 washers (4).
- (3) Remove and discard bumper (1) from fairing (2).

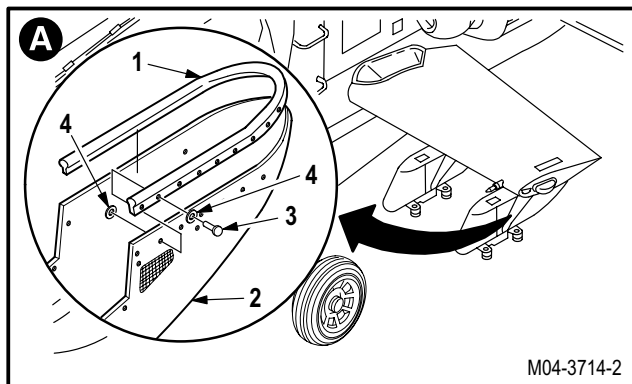
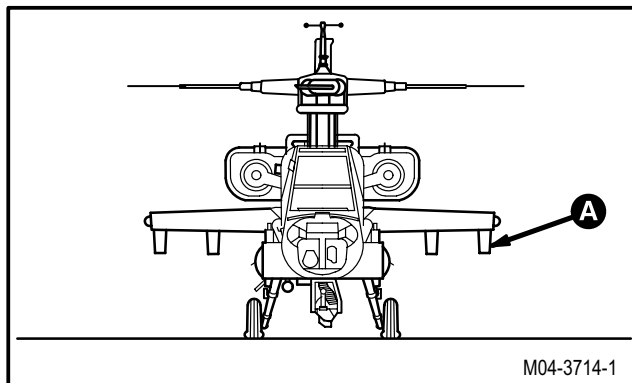

GO TO NEXT PAGE

**16.26. PYLON FAIRING AFT BUMPER REPLACEMENT - continued**



16.26.4. Cleaning

- a. **Remove old adhesive from outboard surface of fairing (2) (para 1.47).**

16.26.5. Inspection

- a. **Check fairing for cracks and delaminated areas (para 2.30).**
- b. **Check fairing for broken or missing turnlock fasteners (TM 1-1500-204-23).**

**NOTE**

Bumper may be cut in curved area to insure proper fit.

16.26.6. Installation



- a. **Using brush, apply adhesive to outboard surface of fairing (2) and inboard surface of bumper (1). Use adhesive (item 18, App F) using brush (item 34, App F).**
- b. **Allow to air dry for 15 MINUTES.**
- c. **Apply bumper (1) to fairing (2). Bumper (1) will stick to fairing (2) upon contact (TM 1-1500-204-23).**

(1) Install 28 rivets (3) and 56 washers (4) on fairing (2) (TM 1-1500-204-23).

- d. **Inspect (QA).**
- e. **Install P3 pylon fairing (para 2.2).**

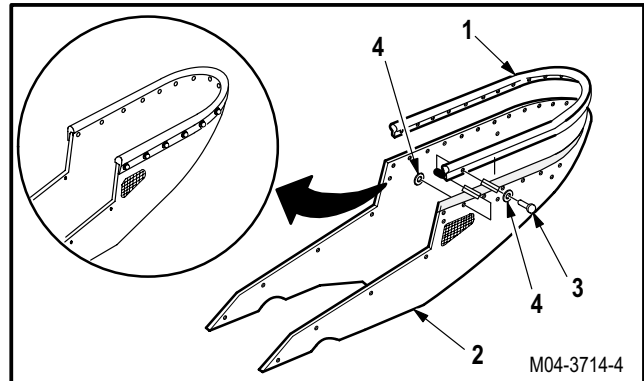

END OF TASK

**16.27. GROUND MAINTENANCE PYLON SWITCH REMOVAL/INSTALLATION**

16.27.1. Description

This task covers: Removal. Cleaning. Inspection. Installation.

16.27.2. Initial Setup

**Tools:**

Aircraft maintenance tool kit (item 373, App H)  
 Light duty laboratory apron (item 27, App H)  
 Chemical protective gloves (item 154, App H)  
 Adjustable air filtering respirator (item 262, App H)

**References:**

TM 1-1520-238-T  
 TM 55-1500-323-24

**Materials/Parts:**

Naphtha (item 127, App F)  
 Sealing compound (item 177, App F)

**Personnel Required:**

68X Armament/Electrical System Repairer  
 68X3F Armament/Electrical System Repairer/  
 Technical Inspector

**Equipment Conditions:**

<u>Ref</u>	<u>Condition</u>
1.57	Helicopter safed
2.2	Access fairing L140 removed

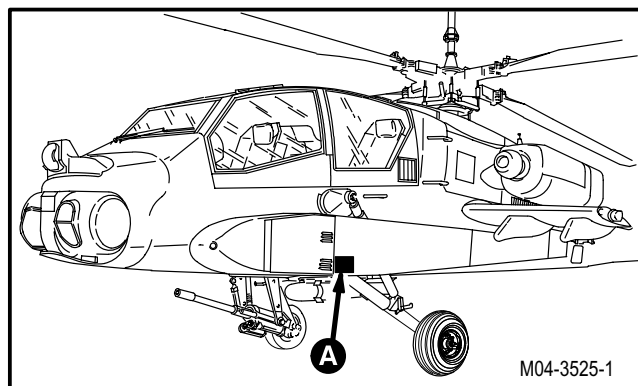

M04-3525-1

GO TO NEXT PAGE

**16.27. GROUND MAINTENANCE PYLON SWITCH REMOVAL/INSTALLATION - continued**

16.27.3. Removal

a. **Remove pylon switch (1) from bracket (2).**

- (1) Remove nut (3) and washer (4) from switch (1).
- (2) Remove switch (1) and lockring (5) from bracket (2).

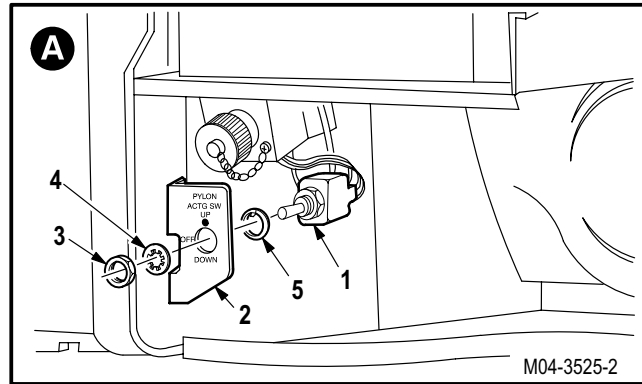

b. **Detach wires (6) from switch (1).**

- (1) Remove sealant from terminal lugs (7) and screws (8) on the back of switch (1).
- (2) Identify three wires (6) and remove three screws (8), washers (9), and terminal lugs (7) from switch (1).

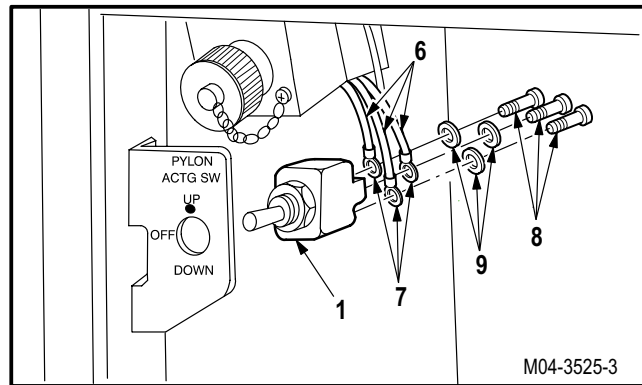

16.27.4. Cleaning

- a. **Clean any remaining sealant off terminal lugs.**  
Use naphtha (item 127, App F).
- b. **Clean removed and attaching parts** (para 1.47).

16.27.5. Inspection

- a. **Check wires for wear, cuts, breaks, and damaged terminal lugs** (TM 55-1500-323-24).

GO TO NEXT PAGE



**16.27. GROUND MAINTENANCE PYLON SWITCH REMOVAL/INSTALLATION - continued**

16.27.6. Installation



**a. Attach three identified wires (6) to switch (1).**

- (1) Install three screws (8) through washers (9) and terminal lugs (7) in switch (1).
- (2) Apply sealant on lugs (7) and screws (8). Use sealing compound (item 177, App F).

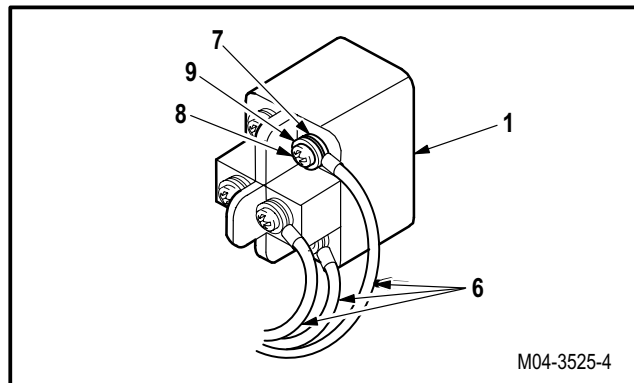

**b. Install switch (1) on bracket (2).**

- (1) Install locking (5) on switch (1).
- (2) Install switch (1) in bracket (2) with tab (10) on locking (5) seated in locator hole (11).
- (3) Adjust length of switch (1) through bracket (2) with adjustment nut (12). One to four threads of switch (1) should extend past nut (3).
- (4) Install washer (4) and nut (3).

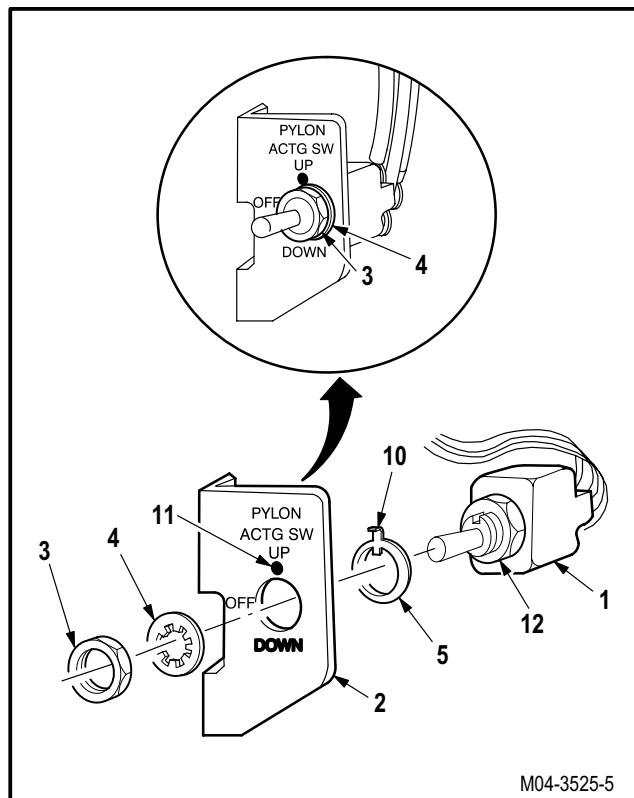

**c. Inspect (QA).**

**d. Perform ground maintenance pylon switch maintenance operational check (TM 1-1520-238-T).**

**e. Install access fairing L140 (para 2.2).**

END OF TASK

---

**16.28. GROUND MAINTENANCE PYLON SWITCH BRACKET REMOVAL/INSTALLATION**

---

16.28.1. Description

This task covers: Removal. Cleaning. Inspection. Installation.

---

16.28.2. Initial Setup

**Tools:**

Aircraft mechanic's tool kit (item 376, App H)

**Personnel Required:**

67R Attack Helicopter Repairer  
67R3F Attack Helicopter Repairer/Technical Inspector

**Equipment Conditions:**

<u>Ref</u>	<u>Condition</u>
1.57	Helicopter safed
2.2	Access fairing L140 removed

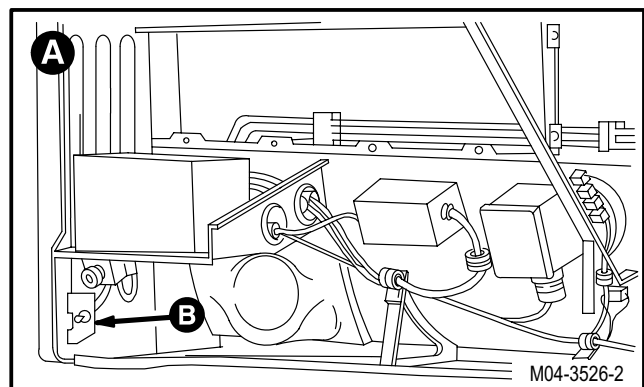
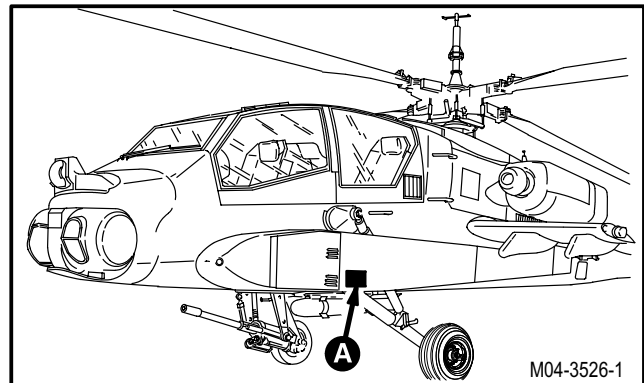

GO TO NEXT PAGE

**16.28. GROUND MAINTENANCE PYLON SWITCH BRACKET REMOVAL/INSTALLATION - continued**

16.28.3. Removal

a. **Remove pylon switch (1) from bracket (2).**

- (1) Remove nut (3) and washer (4) from switch (1).
- (2) Remove switch (1) and locking (5) from bracket (2).

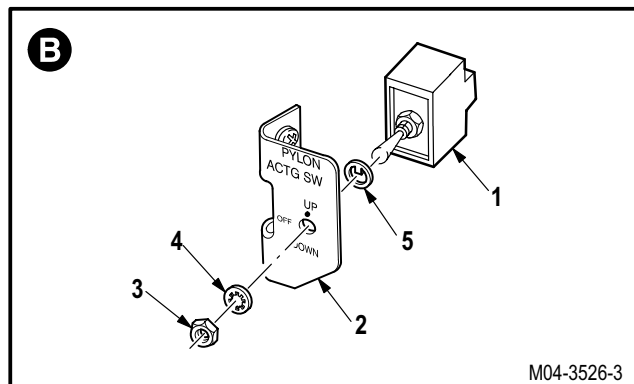

b. **Remove bracket (2) from fuselage (6).**

- (1) Remove two screws (7) and washers (8).
- (2) Remove bracket (2) from fuselage (6).

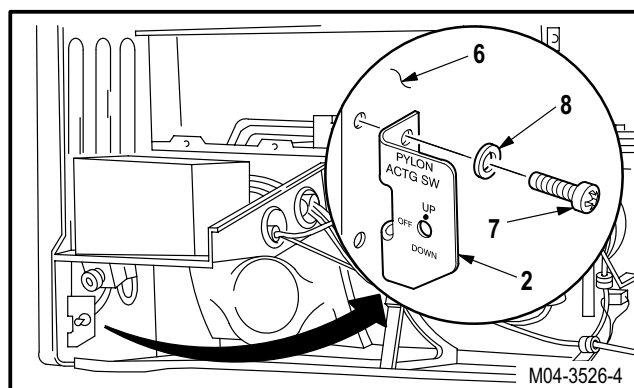

16.28.4. Cleaning

a. **Wipe bracket and attaching hardware with a clean rag.**

16.28.5. Inspection

- a. **Check pylon switch bracket for cracks.** None allowed.
- b. **Check pylon switch bracket for corrosion** (para 1.49).

16.28.6. Installation

a. **Install bracket (2) on fuselage (6).**

- (1) Aline bracket (2) with mounting holes (9).
- (2) Install two screws (7) through washers (8) and bracket (2) into mounting holes (9).

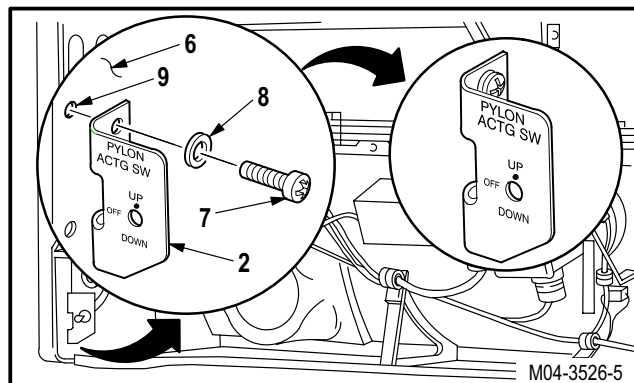

GO TO NEXT PAGE

**16.28. GROUND MAINTENANCE PYLON SWITCH BRACKET REMOVAL/INSTALLATION - continued**

**b. Install switch (1) in bracket (2).**

- (1) Install locking (5) on switch (1).
- (2) Install switch (1) in bracket (2) with tab (10) on locking (5) seated in locator hole (11).
- (3) Adjust length of switch (1) through bracket (2) with adjustment nut (12). One to four threads of switch (1) should extend past nut (3).
- (4) Install washer (4) and nut (3).

**c. Inspect (QA).**

**d. Install access fairing L140 (para 2.2).**

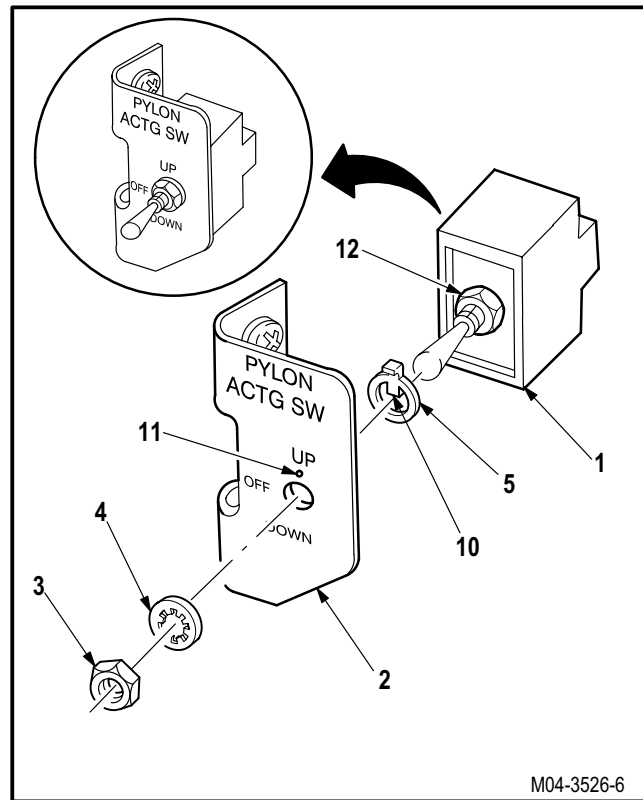

END OF TASK

## SECTION II. COUNTERMEASURE SYSTEM MAINTENANCE

### 16.29. CHAFF DISPENSER SUPPORT REMOVAL/INSTALLATION

#### 16.29.1. Description

This task covers: Removal. Cleaning. Inspection. Installation.

#### 16.29.2. Initial Setup

##### **Tools:**

Airframe repairman's tool kit (item 377, App H)  
 Electrical tool kit (item 378, App H)  
 Light duty laboratory apron (item 27, App H)  
 Chemical protective gloves (item 154, App H)  
 1 1/4-inch blade putty knife (item 199, App H)  
 Ohmmeter (item 218, App H)  
 Adjustable air filtering respirator (item 262, App H)

##### **Personnel Required:**

68G Aircraft Structural Repairer  
 68X Armament/Electrical System Repairer  
 68X3F Armament/Electrical System Repairer/  
 Technical Inspector

##### **References:**

TM 9-1090-208-23-1  
 TM 55-1500-323-24

##### **Equipment Conditions:**

##### **Materials/Parts:**

- Methyl ethyl ketone (item 124, App F)
- Sealing compound (item 156A, App F)

<u>Ref</u>	<u>Condition</u>
1.57	Helicopter safed
TM 9-1090-208-23-1	Chaff dispenser removed

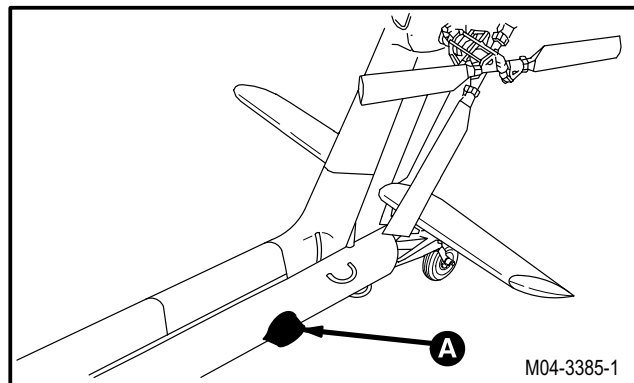

GO TO NEXT PAGE

**16.29. CHAFF DISPENSER SUPPORT REMOVAL/INSTALLATION - continued**

16.29.3. Removal

**CAUTION**

Do not damage chaff dispenser support when using putty knife.

a. **Remove chaff dispenser support (1) from aft fuselage (2).**

- (1) Remove adhesive from 10 screws (3). Use putty knife.
- (2) Remove 10 screws (3) and washers (4).

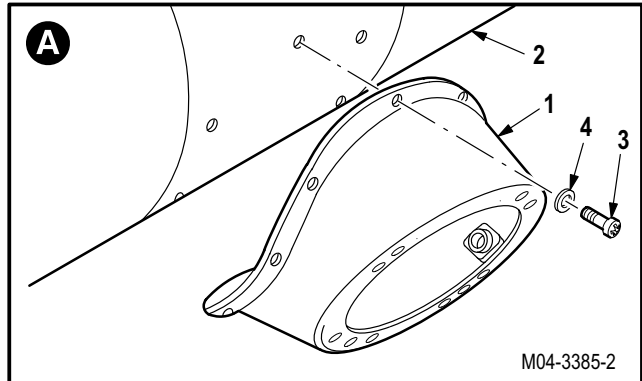

16.29.4. Cleaning

a. **Wipe chaff dispenser support mounting surface with a clean rag.**



b. **Clean chaff dispenser support assembly, 10 screws, and washers.** Use methyl ethyl ketone (item 124, App F) and a clean rag.

16.29.5. Inspection

- a. **Check chaff dispenser support and mounting surface for cracks.** None allowed.
- b. **Check chaff dispenser support and mounting surface for corrosion** (para 1.49).

GO TO NEXT PAGE

---

**16.29. CHAFF DISPENSER SUPPORT REMOVAL/INSTALLATION - continued**



---

16.29.6. Installation**a. Install support (1) on fuselage (2).**

- (1) Aline support (1) to mounting holes on fuselage (2).
- (2) Install 10 screws (3) and washers (4).

**b. Perform electrical bonding check on support (1) (TM 55-1500-323-24).**

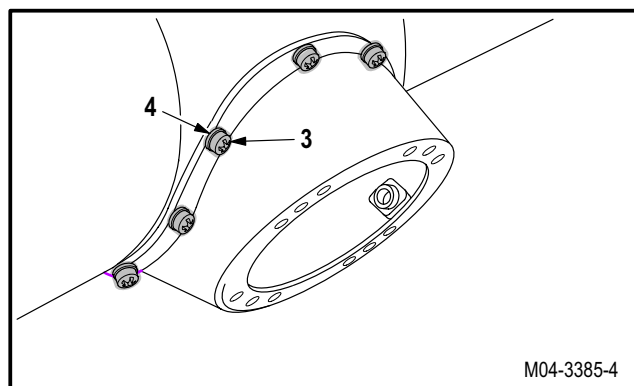
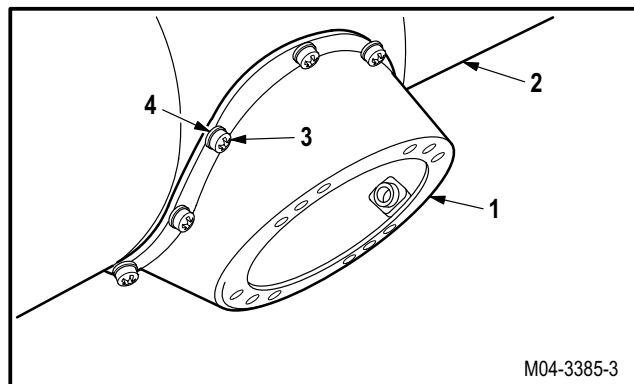
- (1) Bond shall be **0.0025 OHMS** or less. Use ohmmeter.

**c. Apply sealing compound to 10 screws (3) and washers (4).** Use sealing compound (item 156A, App F).**d. Inspect (QA).****e. Install chaff dispenser (TM 9-1090-208-23-1).**

END OF TASK

**16.30. CHAFF SAFETY SWITCH REPLACEMENT**

16.30.1. Description

This task covers: Removal. Cleaning. Inspection. Installation.

16.30.2. Initial Setup

**Tools:**

Electrical tool kit (item 378, App H)

**References:**

TM 9-1090-208-23-1  
 TM 9-1090-208-23-2

**Equipment Conditions:**

<u>Ref</u>	<u>Condition</u>
1.57	Helicopter safed
2.2	Access doors L330 and R330 opened
TM 9-1090-208-23-1	Chaff payload module removed

**Personnel Required:**

68X Armament/Electrical System Repairer  
 68X3F Armament/Electrical System Repairer/  
 Technical Inspector

16.30.3. Removal

- a. Remove chaff safety pin (1) from chaff safety switch S11 (2).

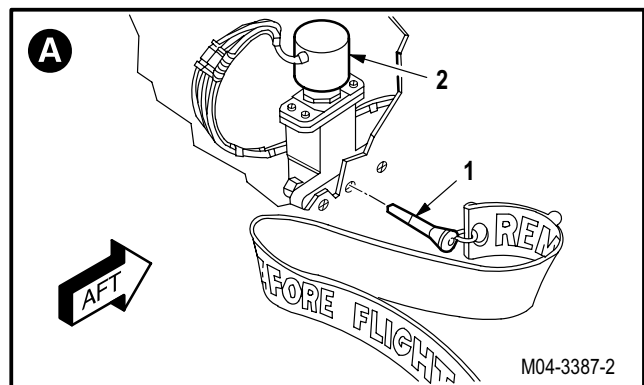
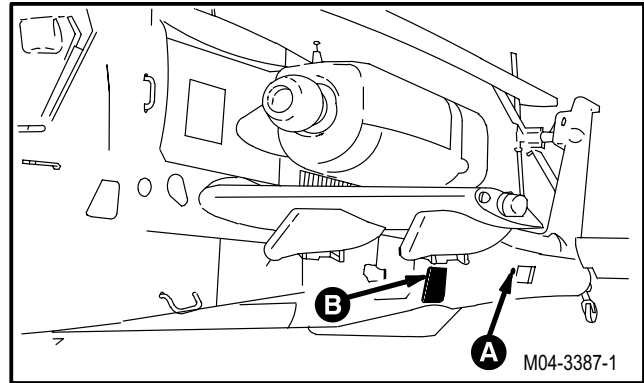

GO TO NEXT PAGE



**16.30. CHAFF SAFETY SWITCH REPLACEMENT - continued**

**b. Open lower stowage bay closure (3).**

- (1) Enter stowage bay (4) in aft fuselage (5).
- (2) Detach hook-and-pile fasteners (6). Open stowage bay closure (3).

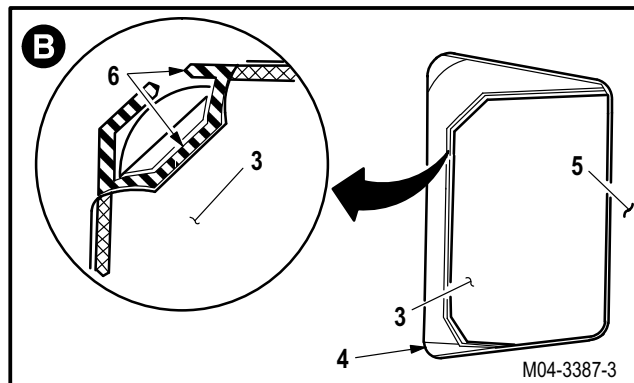

**c. Detach switch (7) ground wire (8) from grounding junction module (9) terminal C.**

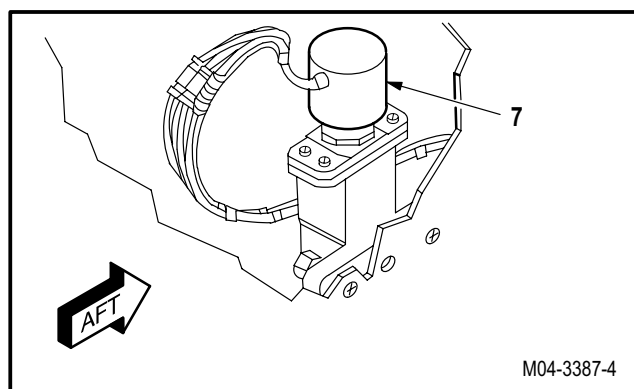

- (1) Identify wire (8).
- (2) Remove wire (8) from module (9).

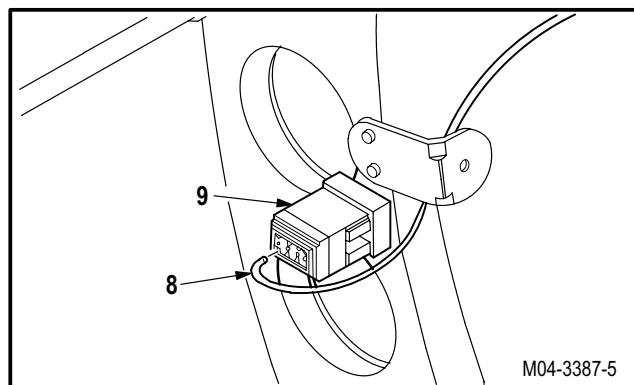

**d. Detach wires (10), (11), (12), and (13) from three splices (14), (15), and (16).**

- (1) Identify wires (10), (11), (12), and (13).
- (2) Detach wire (10) from splice SP3 (14).
- (3) Detach wire (11) from splice SP2 (15).
- (4) Detach wires (12) and (13) from splice SP1 (16).

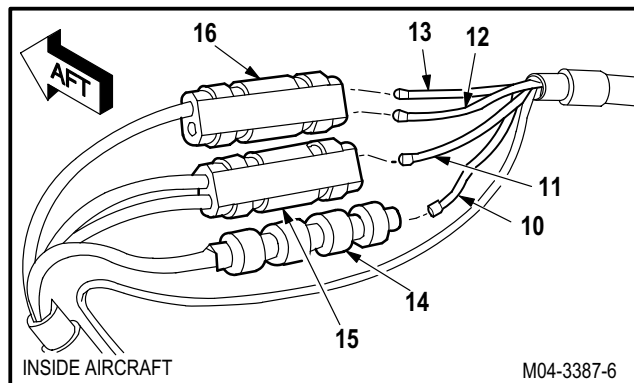

GO TO NEXT PAGE

---

**16.30. CHAFF SAFETY SWITCH REPLACEMENT - continued**

---

**e. Remove switch (7) from aft fuselage (5).**

- (1) Hold two screws (17). Remove two nuts (18) and washers (19).
- (2) Remove switch (7) from fuselage (5).
- (3) Remove two screws (17).

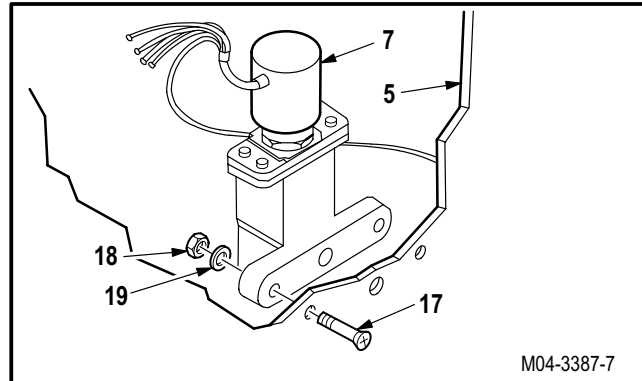

16.30.4. Cleaning

- a. **Wipe switch mounting surface on aft fuselage with a clean rag.**

16.30.5. Inspection

- a. **Check switch mounting surface on aft fuselage for cracks** (para 2.12).
- b. **Check switch mounting surface on aft fuselage for corrosion** (para 1.49).
- c. **Check switch mounting holes on aft fuselage for elongation.** Not to exceed **0.002 INCH**.
- d. **Check hook-and-pile fasteners for tears and loose attachment.** None allowed.

GO TO NEXT PAGE

**16.30. CHAFF SAFETY SWITCH REPLACEMENT - continued**

16.30.6. Installation

**a. Install switch (7) in fuselage (5).**

- (1) Install two screws (17) in holes (20) in aft fuselage (5).
- (2) Position switch (7) on two screws (76).
- (3) Install two washers (19) and nut (18).

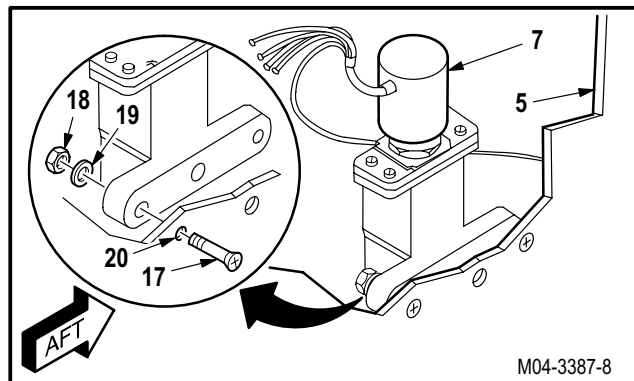

**b. Attach identified wires (10), (11), (12), and (13) to three splices (14), (15), and (16).**

- (1) Attach wire (10) to splice SP3 (14).
- (2) Attach wire (11) to splice SP2 (15).
- (3) Attach wires (12) and (13) to splice SP1 (16).

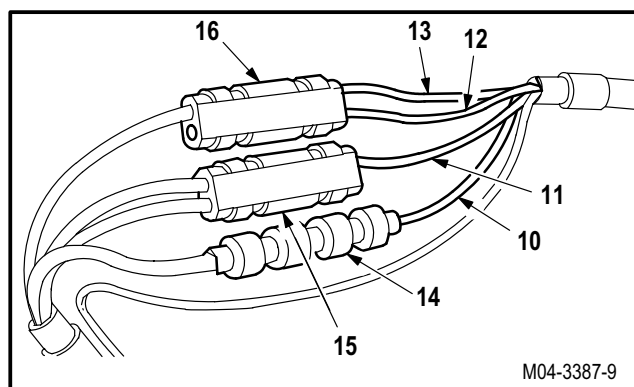

**c. Attach wire (8) to module (9) terminal C.**

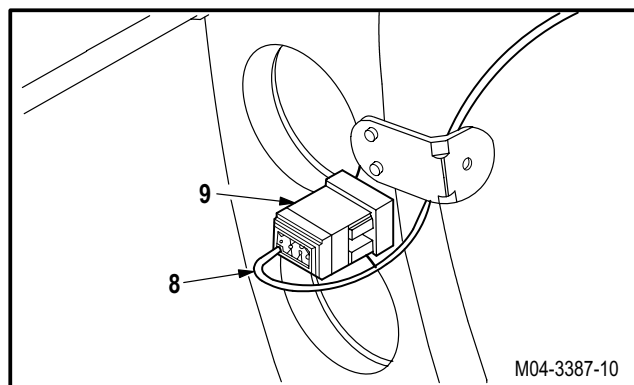

**d. Inspect (QA).**

**e. Install pin (1) in switch (7).**

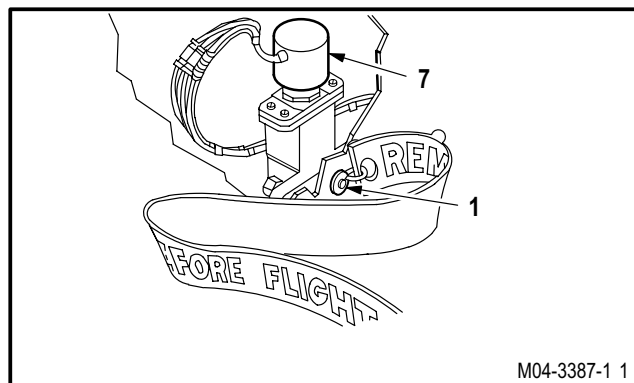

GO TO NEXT PAGE

---

**16.30. CHAFF SAFETY SWITCH REPLACEMENT - continued**

---

**f. Secure closure (3).**

- (1) Position stowage bay closure (3) over access to aft fuselage (5).
- (2) Fasten hook-and-pile fasteners (6).

**g. Secure access doors L330 and R330 (para 2.2).**

**h. Install chaff payload module (TM 9-1090-208-23-1).**

**i. Perform chaff dispenser system maintenance operational check (TM 9-1090-208-23-2).**

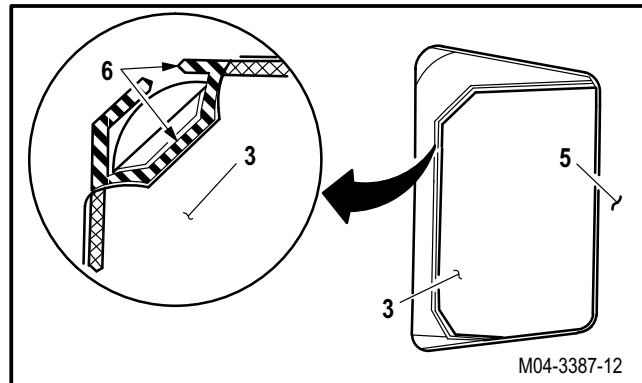

END OF TASK

**16.30A. RADAR JAMMER BLOWER ASSEMBLY REMOVAL/INSTALLATION**

16.30.A.1. Description

This task covers: Removal. Cleaning. Inspection. Installation.

16.30.A.2. Initial Setup

**Tools:**

- Electrical tool kit (item 378, App H)
- Light duty laboratory apron (item 27, App H)
- Chemical protective gloves (item 154, App H)
- Ohmmeter (item 218, App H)
- Adjustable air filtering respirator (item 262, App H)

**References:**

- TM 11-1520-238-23-1
- TM 11-1520-238-23-2
- TM 55-1500-323-24

**Materials/Parts:**

- Sealing compound (item 176, App F)

**Equipment Conditions:**

<u>Ref</u>	<u>Condition</u>
1.57	Helicopter safed
2.2	Access doors L90 opened
TM 11-1520-238-23-1	Radar jammer receiver/transmitter removed

**Personnel Required:**

- 68X Armament/Electrical System Repairer
- 68X3F Armament/Electrical System Repairer/  
Technical Inspector

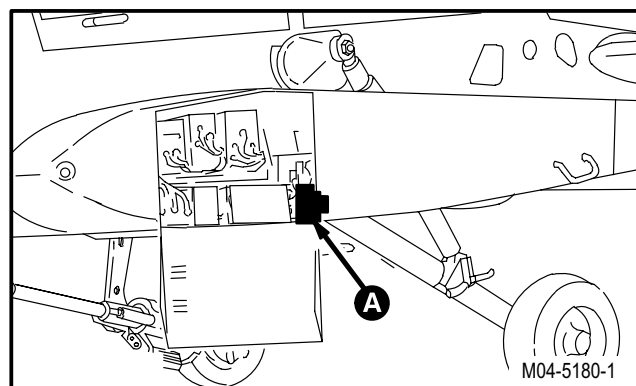

GO TO NEXT PAGE

**16.30A. RADAR JAMMER BLOWER ASSEMBLY REMOVAL/INSTALLATION - continued**

16.30A.3. Removal

**a. Install cover plate (1) on blower assembly (2).**

- (1) Obtain cover plate (1) from ASE stowage bag.
- (2) Slide cover plate (1) under retention clips (3) and align notch on index pin (4).
- (3) Lock two spring mounted fasteners (5) by turning clockwise.

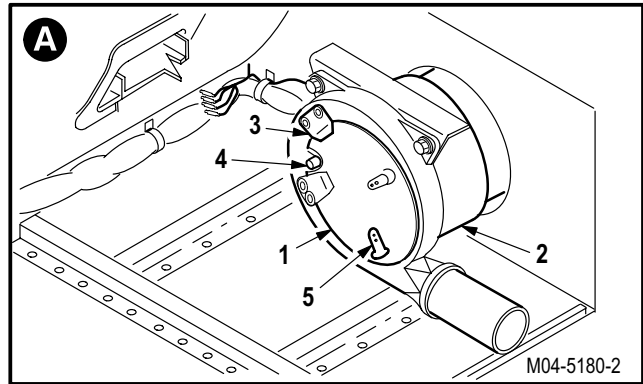

**b. Identify and depin four wires (6) from splices (7) (TM 55-1500-323-24).**

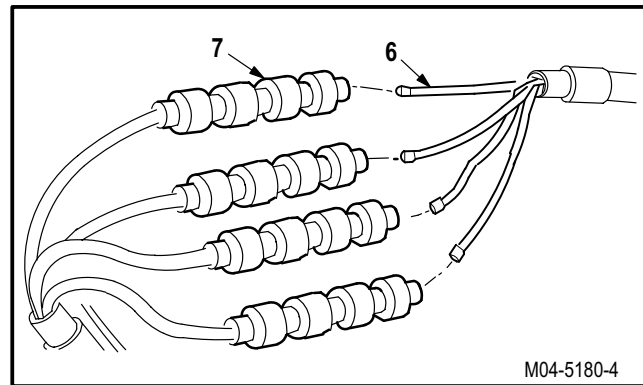

**c. Remove blower assembly (2) from two brackets (8).**

- (1) Remove sealing compound from three bolts (9) and washers (10).
- (2) Remove three bolts (9) and washers (10) from bracket (8).
- (3) Remove blower assembly (2) from brackets (8).

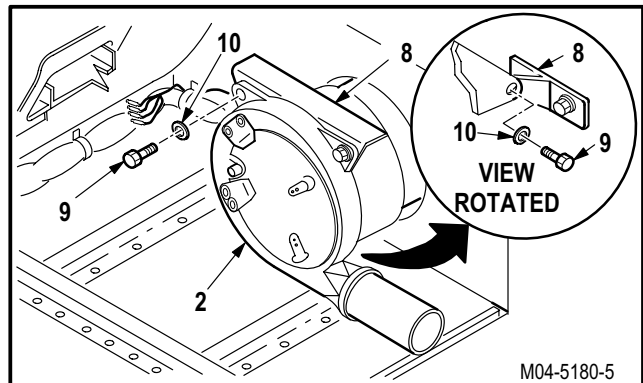

GO TO NEXT PAGE

## 16.30A. RADAR JAMMER BLOWER ASSEMBLY REMOVAL/INSTALLATION - continued

### 16.30A.4. Cleaning

- a. **Wipe switch mounting surface on aft fuselage with a clean rag.**

### 16.30A.5. Inspection

- a. **Check blower assembly for cracks.** None allowed.
- b. **Check blower assembly for corrosion** (para 1.49).

### 16.30A.6. Installation

- a. **Install blower assembly (2) on two brackets (8).**

- (1) Align blower assembly (2) on brackets (8).
- (2) Install three bolts (9) and three washers (10). Do not tighten.

- b. **Adjust blower assembly (2) by tightening bolts (9) until access door can freely open and close.**

- c. **Pin four identified wires (6) to splices (7)** (TM 55-1500-323-24).

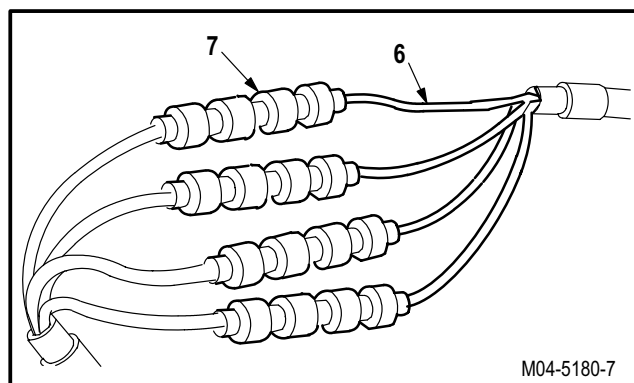
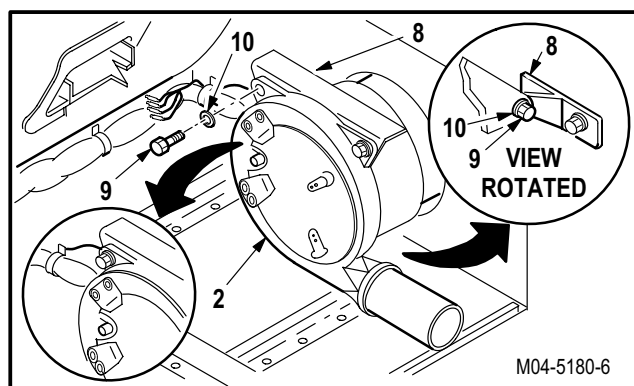

GO TO NEXT PAGE

**16.30A. RADAR JAMMER BLOWER ASSEMBLY REMOVAL/INSTALLATION - continued**

d. **Remove blower cover plate (1) from blower assembly (2).**

- (1) Unlock two spring mounted fasteners (5) by turning counterclockwise.
- (2) Slide cover plate (1) out from retention clips (3) and index pin (4).
- (3) Store in ASE stowage bag.

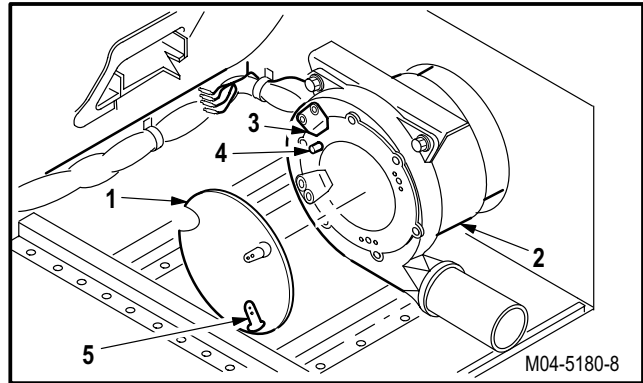

e. **Perform electrical bond check** (TM 55-1500-323-24).

- (1) Bond shall be **1.0 OHM** or less. Use ohmmeter.



f. **Apply sealing compound to three bolts (9) and washers (10).** Use sealing compound (item 176, App F).

g. **Inspect (QA).**

h. **Install radar jammer receiver/transmitter** (TM 11-1520-238-23-1).

i. **Secure access doors L90** (para 2.2).

j. **Perform radar jammer operational check** (TM 11-1520-238-23-2).

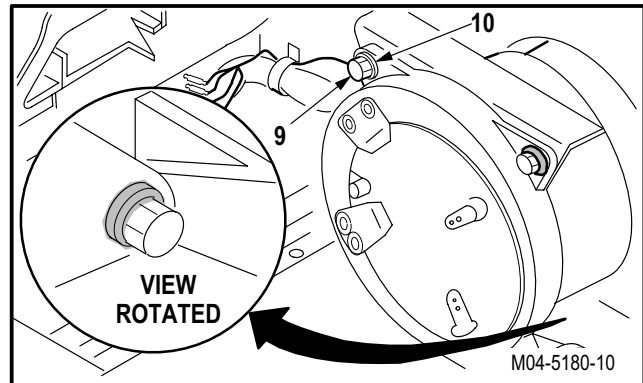

END OF TASK



---

**16.30B. RADAR JAMMER BLOWER ASSEMBLY DISASSEMBLY/ASSEMBLY (AVIM)**

---

16.30.B. Description

This task covers: Disassembly. Cleaning. Inspection. Repair. Assembly.

---

16.30.B.2. Initial Setup**Tools:**

Adjustable air filtering respirator (item 262, App H)  
 Chemical protective gloves (item 154, App H)  
 Electrical tool kit (item 378, App H)  
 Light duty laboratory apron (item 27, App H)

**Personnel Required:**

68X Armament/Electrical System Repairer  
 68X3F Armament/Electrical System Repairer/  
 Technical Inspector

**Materials/Parts:**

Adhesive (item 12, App F)  
 Adhesive (item 20A, App F)  
 Cloth (item 48, App F)

**References:**

TM 1-1500-204-23  
 TM 55-1500-323-24

---

16.30.B.3. Removal

a. **Remove blower cover plate (1) from radar jammer blower assembly (2).**

- (1) Slide blower cover plate (1) under retention clips (3) and align notch on index pin (4).
- (2) Lock two spring mounted fasteners (5) by turning clockwise.

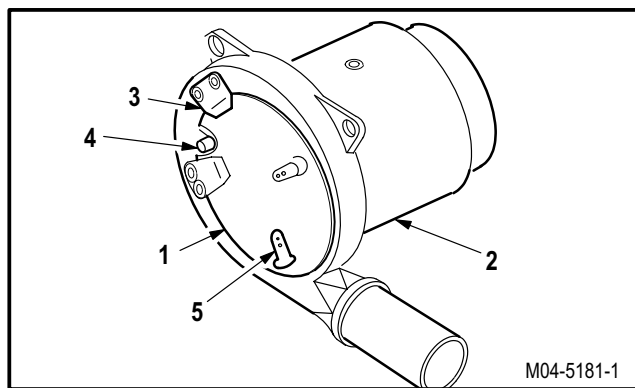

GO TO NEXT PAGE

**16.30B. RADAR JAMMER BLOWER ASSEMBLY DISASSEMBLY/ASSEMBLY (AVIM) - continued**

**b. Remove entrance cove plate (6) from centrifugal fan (7).**

- (1) Remove six screws (8) from plate (6) and fan (7).
- (2) Remove plate (6) from fan (7).

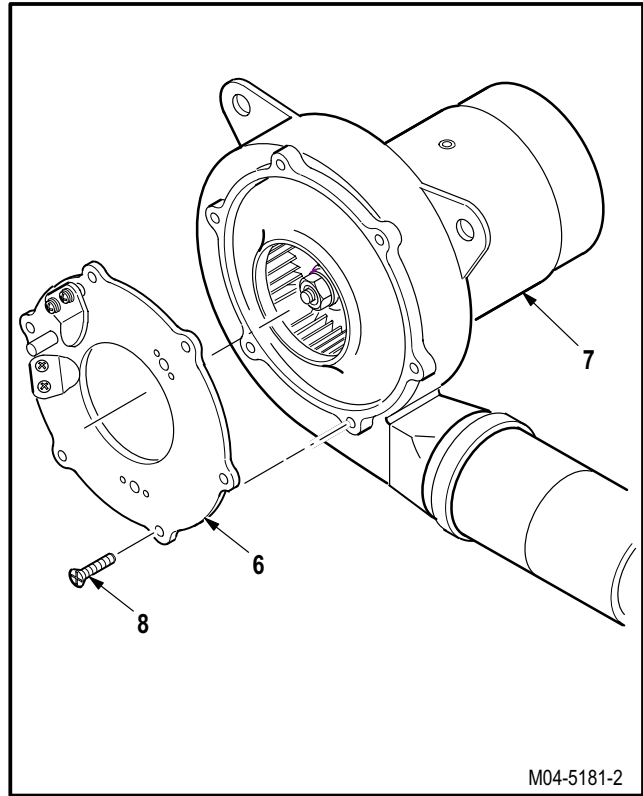

**c. Remove axial fan impeller (9) from centrifugal fan (7).**

- (1) Remove nut (10) and washer (11) from impeller (9) and stator assembly shaft (12).
- (2) Remove impeller (9) from centrifugal fan (7).
- (3) Remove woodruff key (13) from stator assembly shaft (12).

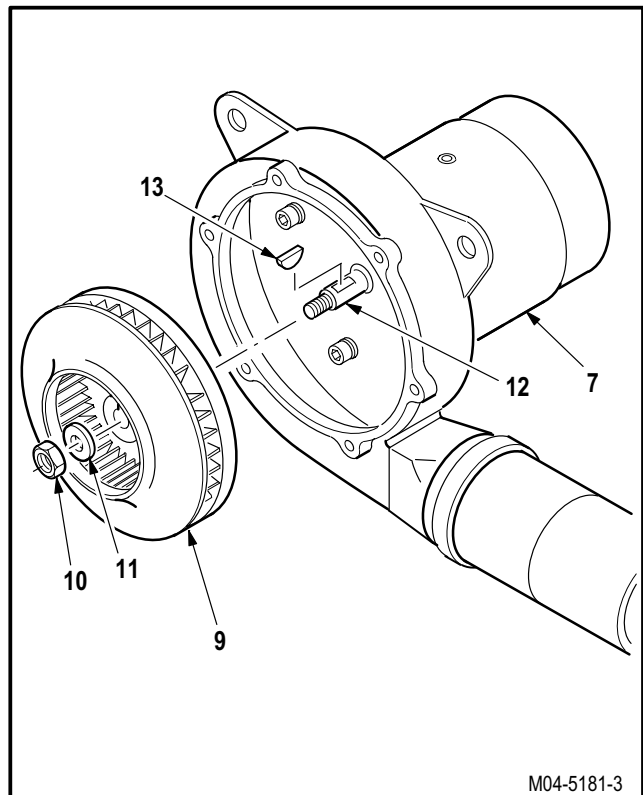

GO TO NEXT PAGE

**16.30B. RADAR JAMMER BLOWER ASSEMBLY DISASSEMBLY/ASSEMBLY (AVIM) - continued**

d. **Remove housing assembly (14) from motor housing assembly (15).**

- (1) Remove four screws (16) and washers (17) from housing assembly (15).
- (2) Remove housing (14) from motor housing assembly (15).

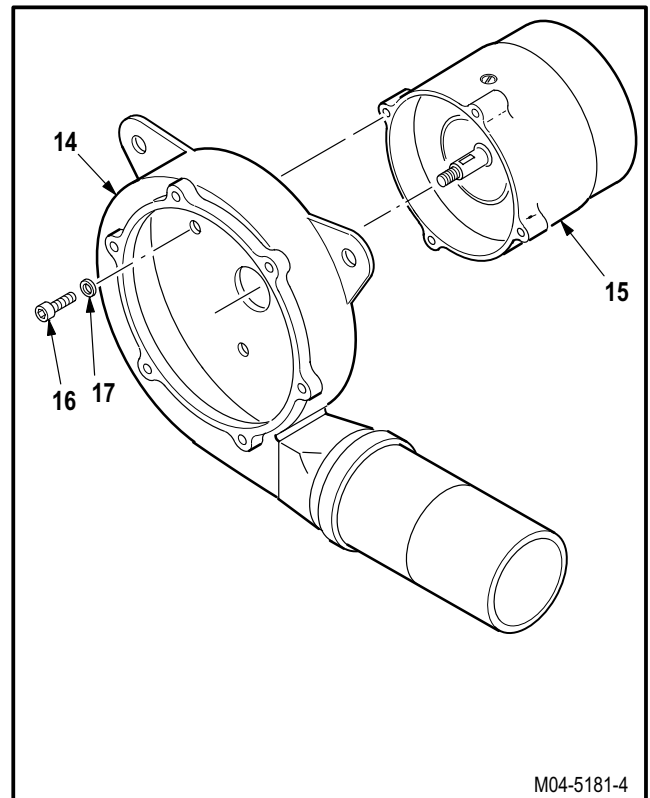

e. **Remove shaft assembly rotor (18) from motor housing (15).**

- (1) Remove bearing (19) from shaft assembly rotor (18).

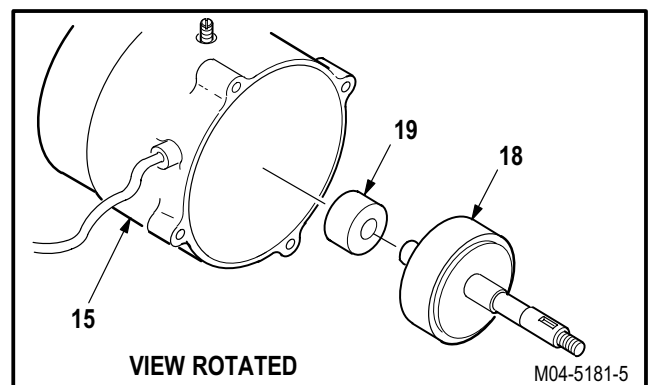

GO TO NEXT PAGE

**16.30B. RADAR JAMMER BLOWER ASSEMBLY DISASSEMBLY/ASSEMBLY (AVIM) - continued**

**f. Remove stator assembly (20) from motor housing (15).**

- (1) Loosen set screw (21) from motor housing (15).
- (2) Remove sealing compound from wire harness (para 1.47).
- (3) Remove stator assembly (20) from motor housing assembly (15).
- (4) Remove four spring tensioner washers (22) from motor housing assembly (15).

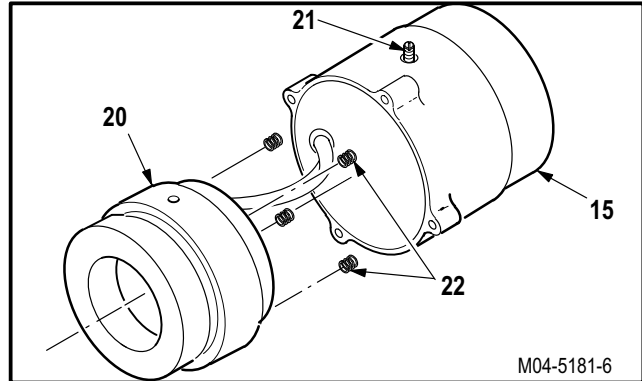

**16.30.B.4. Cleaning**

- a. **Wipe removed and attaching parts with a clean rag.**

**16.30.B.5. Inspection**

- a. **Check flex duct and blower for cracks.** None allowed.
- b. **Check flex duct and blower for corrosion** (para 1.49).
- c. **Check removed and attaching parts for stripped or damaged threads or loose rivets** (TM 1-1500-204-23). None allowed.
- d. **Check wire harness contact pins for bent or damaged pins** (TM 55-1500-323-24).

GO TO NEXT PAGE

**16.30B. RADAR JAMMER BLOWER ASSEMBLY DISASSEMBLY/ASSEMBLY (AVIM) - continued**

16.30B.6. Repair

**a. Repair damaged retention clips (23) on plate (6).**

- (1) Remove screw (24) and washer (25) from retention clip (23).
- (2) Remove retention clip (23) and sleeve spacer (26) from plate (6).
- (3) Position sleeve spacer (26) and retention clip (23) on plate (6).
- (4) Install washer (25) and screw (24) through retention clip (23) and spacer (26) into plate (6).

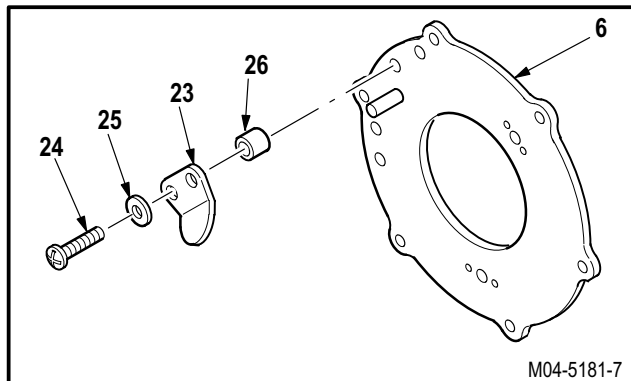

**b. Repair damaged data plate (27) on housing (14).**

- (1) Record all data on new name plate (27).
- (2) Remove old plate (27) from housing (14).
  - (a) Peel up corner of plate (27). Use putty knife.
  - (b) Remove and discard old plate (27) from housing (14).
- (3) Clean plate mounting area (para 1.47).
- (4) Transcribe recorded data on new plate (27). Use die set.

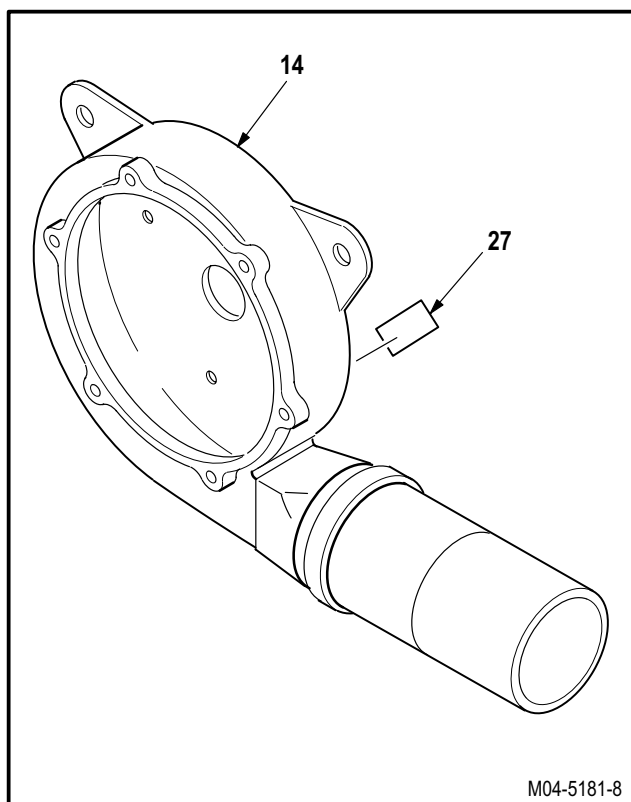

<b>Noah Howden, Inc.</b>				CIN
CORONA, CA				58163
FAN, CENTRIFUGAL				
RATING	138 CRM @ 14 IN WG Ps			
	DENSITY .0765 LBS/FT <sup>3</sup>			
MOTOR	115/200 VAC	3 PHASE	400Hz	
PART NO	41040-	SER NO		
CONTRACT				
HH P/N	02731S0CN7-267521001			
	DATE			

GO TO NEXT PAGE

16.30B. RADAR JAMMER BLOWER ASSEMBLY DISASSEMBLY/ASSEMBLY (AVIM) - continued



c. Install new data plate (27) on housing (14).

- (1) Remove backing from new plate (27).
- (2) Position plate (27) on housing (14).
- (3) Press plate (27) on housing (14).
- (4) Place a bead of adhesive around the edge of plate (27). Use adhesive (item 12, App F).

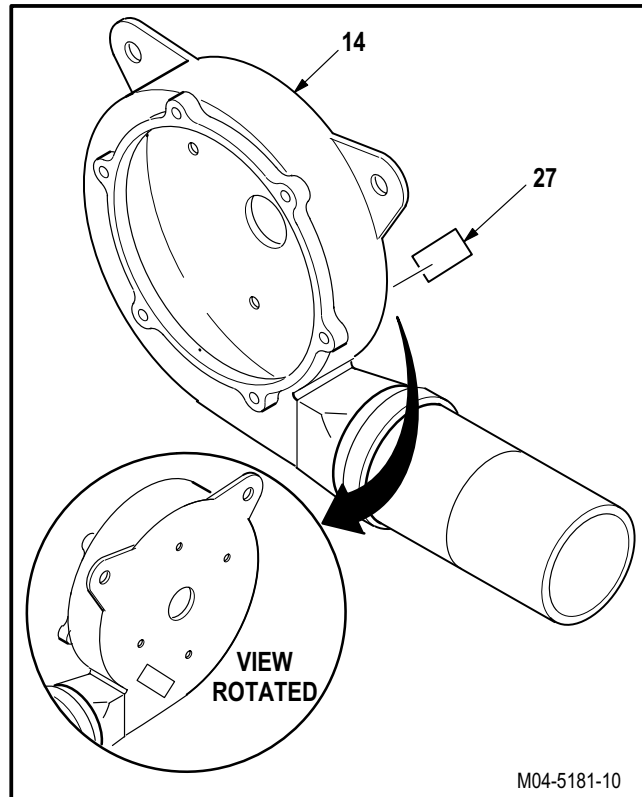

GO TO NEXT PAGE

**16.30B. RADAR JAMMER BLOWER ASSEMBLY DISASSEMBLY/ASSEMBLY (AVIM) - continued**16.30.B.7. Installation**a. Install stator assembly (20) into motor housing (15).**

- (1) Position four spring tensioner washers (22) into motor housing assembly (15).
- (2) Put wire harness (28) for stator (20) through opening in motor housing (15).
- (3) Position stator assembly on spring tensioner washers (22) in motor housing (15).
- (4) Aline stator assembly (20) with motor housing (15) and tighten set screw (21).
- (5) Apply sealing compound around stator assembly wiring harness. Use sealing compound (adhesive (item 20A, App F).

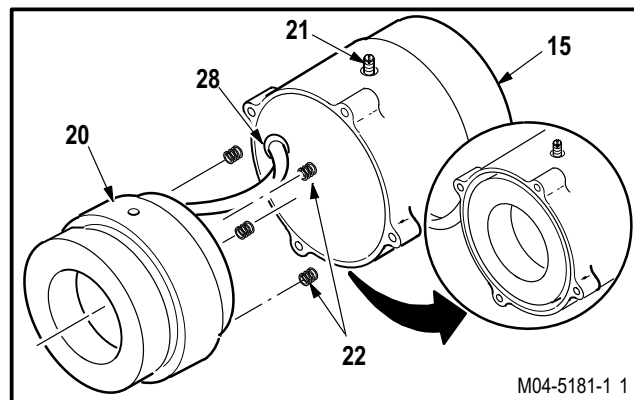
**b. Install shaft assembly rotor (18) into motor housing (15).**

- (1) Put bearing (19) on shaft assembly rotor (18).
- (2) Install shaft assembly rotor (18) into motor housing (15).

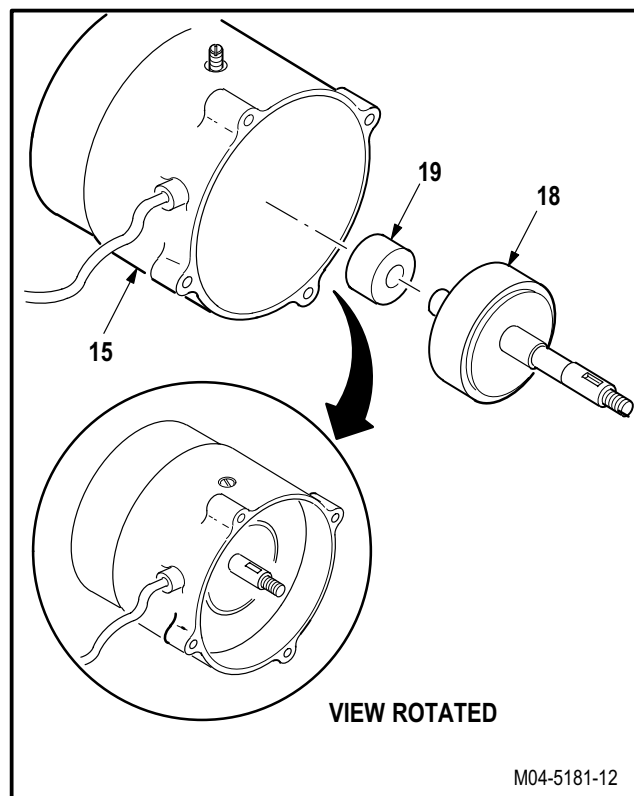

GO TO NEXT PAGE

**16.30B. RADAR JAMMER BLOWER ASSEMBLY DISASSEMBLY/ASSEMBLY (AVIM) - continued**

**c. Install housing assembly (14) on motor housing assembly (15).**

- (1) Aline housing assembly (14) with the screw holes (29) on the motor housing assembly (15).
- (2) Install four screws (16) and washers (17) into housing assembly (15).

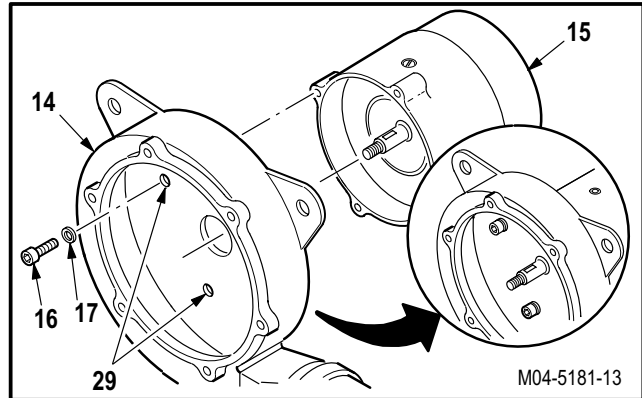

**d. Install axial fan impeller (9) on centrifugal fan (7)**

- (1) Install woodruff key (13) on stator assembly sahft (12).
- (2) Install impeller (9) on centrifugal fan (7).
- (3) Install nut (10) and washer (11) on impeller (9) and stator assembly sahft (12).

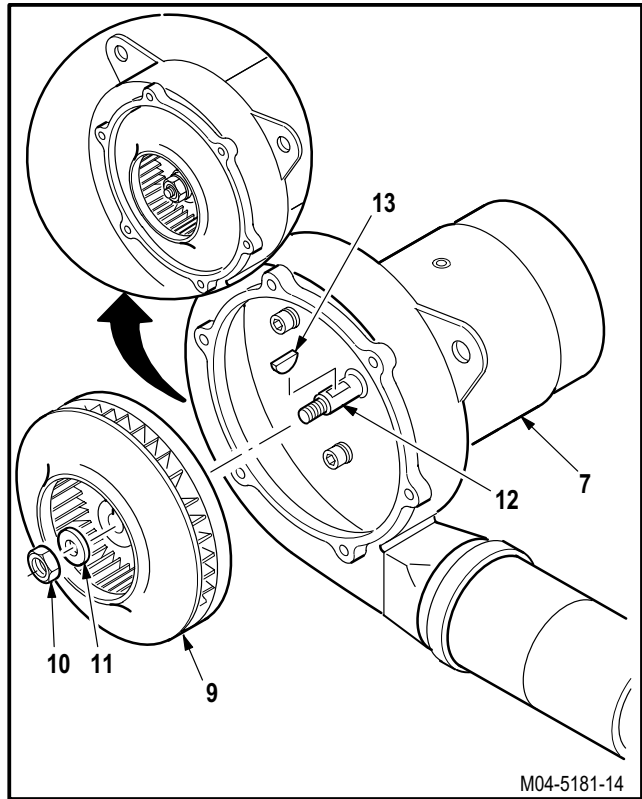

GO TO NEXT PAGE



**16.30B. RADAR JAMMER BLOWER ASSEMBLY DISASSEMBLY/ASSEMBLY (AVIM) - continued****e. Install entrance cove plate (6) on centrifugal fan (7).**

- (1) Install plate (6) on fan (7).
- (2) Install six screws (8) on plate (6) and fan (7).

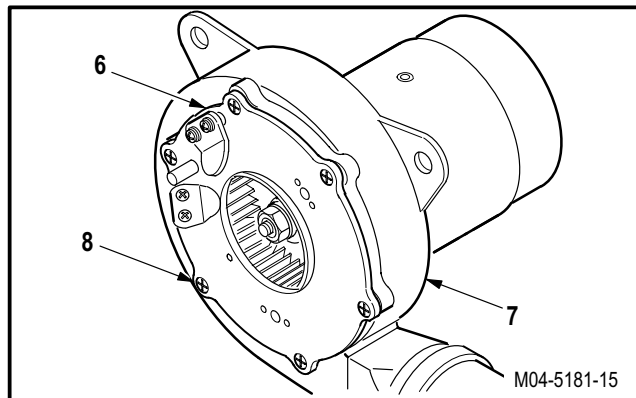
**f. Install blower cover plate (1).**

- (1) Slide blower cover plate (1) into retention clips (3) and slide notch on index pin (4).
- (2) Lock two spring mounted fasteners (5) by turning counterclockwise and observing the fasteners eject free.

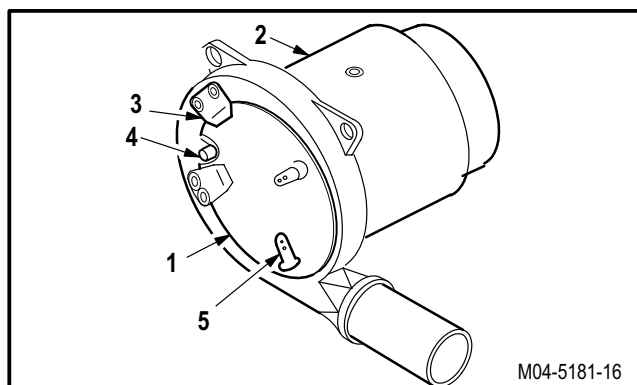
**g. Inspect (QA).**

END OF TASK



## SECTION III. WINTERIZATION AND BATTERY COLD START SYSTEM MAINTENANCE

### 16.31. WINTERIZATION ACCUMULATOR REMOVAL/INSTALLATION

#### 16.31.1. Description

This task covers: Removal. Cleaning. Inspection. Installation.

#### 16.31.2. Initial Setup

**Tools:**

Aircraft mechanic's tool kit (item 376, App H)

**References:**

TM 1-1520-238-T

**Equipment Conditions:**

<u>Ref</u>	<u>Condition</u>
1.57	Helicopter safed
2.2	Access door T355 and R325 removed
1.34	Utility hydraulic system serviced
1.38	Pneumatic accumulator vented

**Personnel Required:**

67R	Attack Helicopter Repairer
67R3F	Attack Helicopter Repairer/Technical Inspector

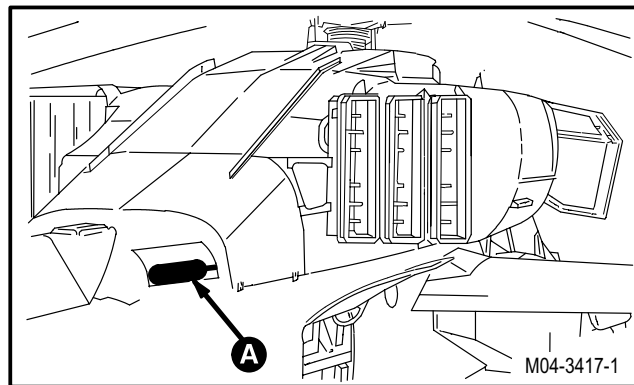

GO TO NEXT PAGE

**16.31. WINTERIZATION ACCUMULATOR REMOVAL/INSTALLATION - continued**

16.31.3. Removal

a. **Remove tube (1) from tube tee (2).**

(1) Remove nut (3) from tee (2).

b. **Remove accumulator (4) and tube (1) from deck (5).**

(1) Remove screw (6) and clamp (7) from bracket (8).

(2) Remove two bolts (9) from clamp (10).

(3) Remove two bolts (9) from clamp (11).

(4) Remove accumulator (4) and tube (1) from deck (5).

c. **Install cap (12) on tee (2).**

16.31.4. Cleaning

a. **Wipe removed and attaching parts with a clean rag.**

16.31.5. Inspection

a. **Check accumulator, brackets, clamps, and tube for cracks.** None allowed.

b. **Check accumulator, brackets, clamps, and tube for corrosion** (para 1.49).

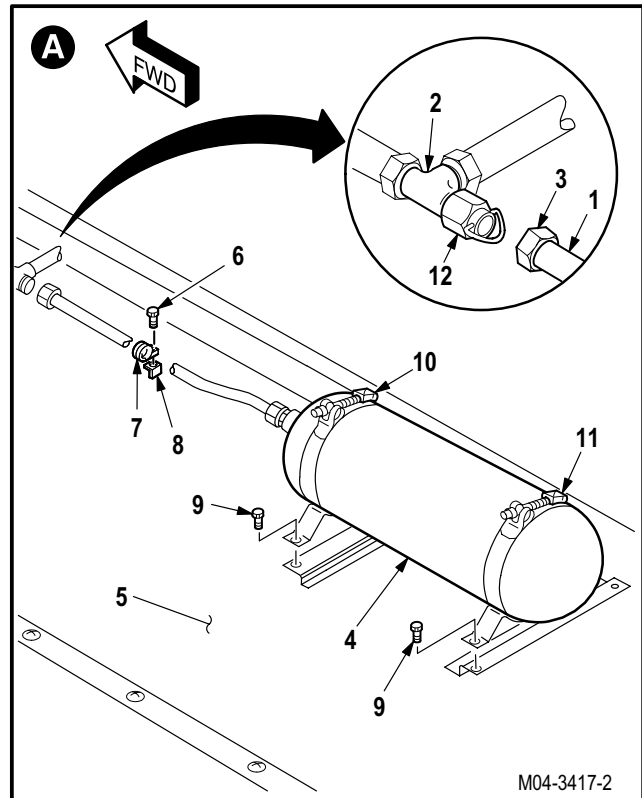

GO TO NEXT PAGE

**16.31. WINTERIZATION ACCUMULATOR REMOVAL/INSTALLATION - continued**

16.31.6. Installation

**a. Install accumulator (4) on deck (5).**

- (1) Aline clamp (11) with bracket (13). Install two bolts (9) through clamp (11) and bracket (13).
- (2) Aline clamp (10) with bracket (14). Install two bolts (9) through clamp (10) and bracket (14).

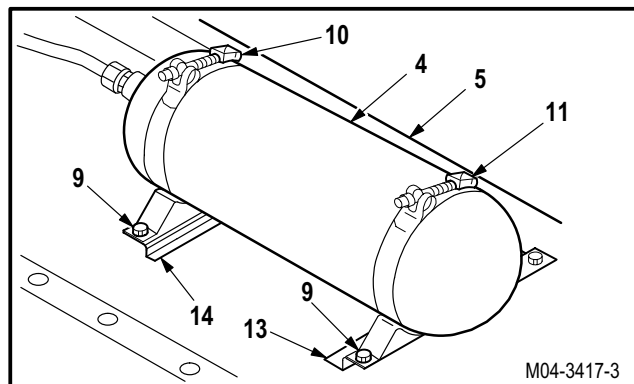

**b. Remove cap (12) from tee (2).**

**c. Install tube (1) on tee (2).**

- (1) Tighten nut (3).

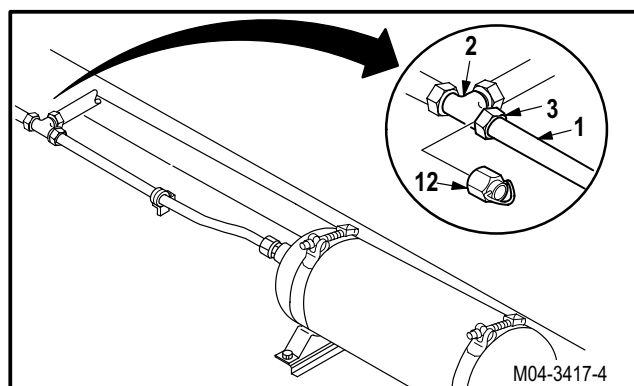

**d. Install clamp (7) on bracket (8).**

- (1) Install screw (6) through clamp (7) and bracket (8).

**e. Service utility hydraulic accumulator and winterization accumulator (para 1.36).**

**f. Inspect (QA).**

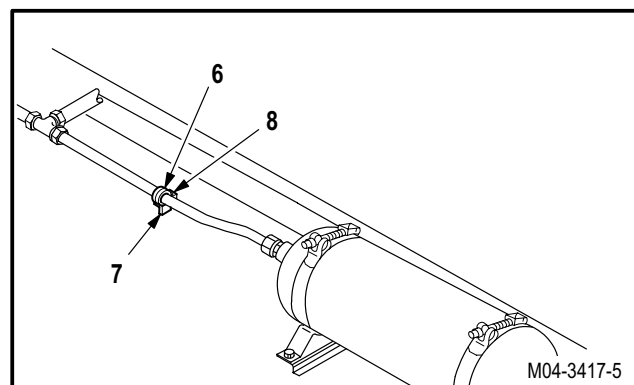

**NOTE**

Added servicing is not required after hydraulic system has been hand pumped to 3000 psi.

**g. Perform winterization system maintenance operational check (TM 1-1520-238-T).**

**h. Secure access doors R325 and T355 (para 2.2).**

END OF TASK

---

## 16.32. BATTERY HEATER BLANKET REMOVAL/INSTALLATION

---

### 16.32.1. Description

This task covers: Removal. Cleaning. Inspection. Installation.

---

### 16.32.2. Initial Setup

#### **Tools:**

Electrical tool kit (item 378, App H)

#### **References:**

TM 1-1520-238-T  
TM 11-6140-203-14-2

#### **Personnel Required:**

68X Armament/Electrical System Repairer  
68X3F Armament/Electrical System Repairer/  
Technical Inspector

#### **Equipment Conditions:**

<u>Ref</u>	<u>Condition</u>
1.57	Helicopter safed
2.2	Access door R295 opened

---

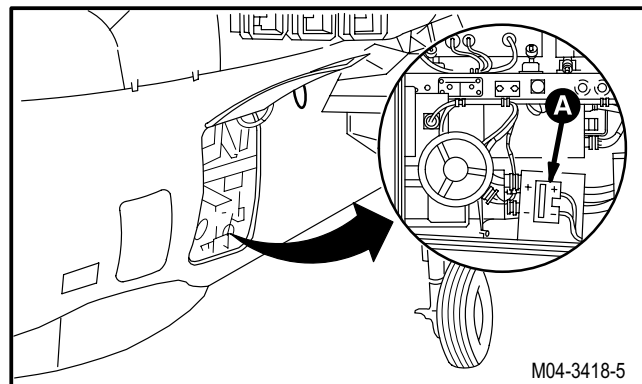

GO TO NEXT PAGE

---

**16.32. BATTERY HEATER BLANKET REMOVAL/INSTALLATION - continued**

---

**16.32.3. Removal**

- a. **Identify and detach wires (1) and (2) from splices P80 SP1 (3) and P80 SP2 (4).**
- b. **Remove upper spring (5) and lower spring (6) from heater blanket (7).**
- c. **Remove heater blanket (7) from battery (8).**

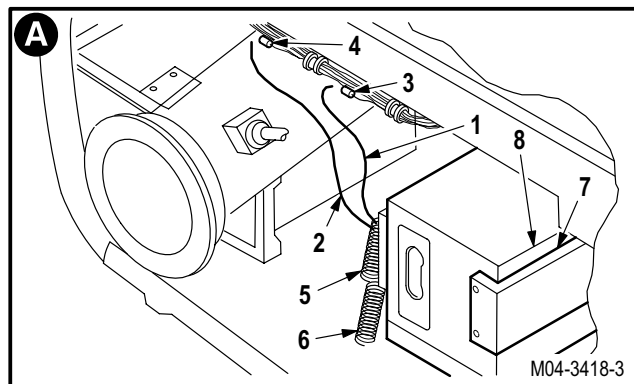
**16.32.4. Cleaning**

- a. **Wipe removed and attaching parts with a clean rag.**

**16.32.5. Inspection**

- a. **Check blanket for broken wires, springs, or tears and cuts. None allowed.**
- b. **Check battery for corrosion (TM 11-6140-203-14-2).**

**16.32.6. Installation****NOTE**

Thermostat of heater blanket must face aft of helicopter.

- a. **Install blanket (7) on battery (8).**
  - (1) Wrap blanket (7) around battery (8).
  - (2) Install spring (5) in hole (9) of blanket (7).
  - (3) Install spring (6) in hole (10) of blanket (7).
- b. **Attach yellow wire (1) to splice P80 SP1 (3).**
- c. **Attach blue wire (2) to splice P80 SP2 (4).**

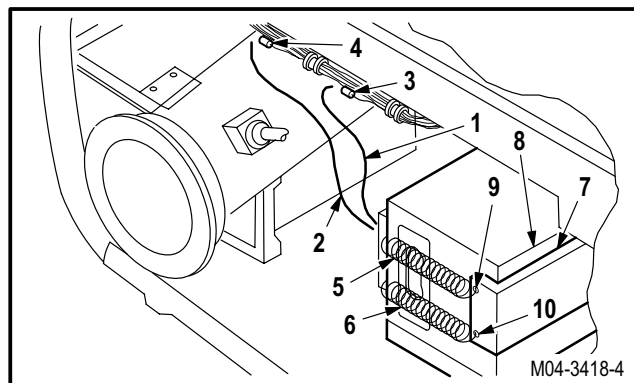

GO TO NEXT PAGE

---

**16.32. BATTERY HEATER BLANKET REMOVAL/INSTALLATION - continued**

---

- d. **Inspect (QA).**
- e. **Perform winterization system maintenance operational check (TM 1-1520-238-T).**
- f. **Secure access door R295 (para 2.2).**

END OF TASK



**16.33. APU COLD START - BATTERY**

16.33.1. Description

This task covers: Preparation. Operation. Removal.

16.33.2. Initial Setup

**Tools:**

- Aircraft mechanic's tool kit (item 376, App H)
- Emergency battery cable (Figure D-448, App D)
- External battery

**Personnel Required:**

- 67R Attack Helicopter Repairer  
One person to assist
- 67R3F Attack Helicopter Repairer/Technical  
Inspector

**Equipment Conditions:**

<u>Ref</u>	<u>Condition</u>
1.57	Helicopter safed
2.2	Access door B60R opened
9.40	Battery connected
16.31	Winterization accumulator installed
16.32	Heater blanket installed

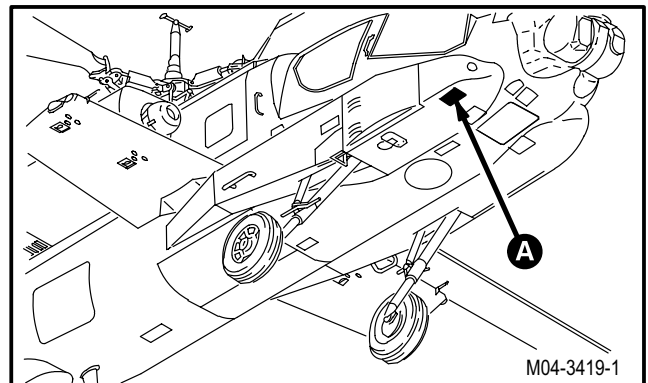

GO TO NEXT PAGE

**16.33. APU COLD START - BATTERY - continued**

16.33.3. Preparation

a. **Attach connector (1) to ground service utility receptacle J16 (2).**

- (1) Remove cap (3) from receptacle (2).
- (2) Remove cap (4) from connector (1).
- (3) Attach connector (1) to receptacle (2).

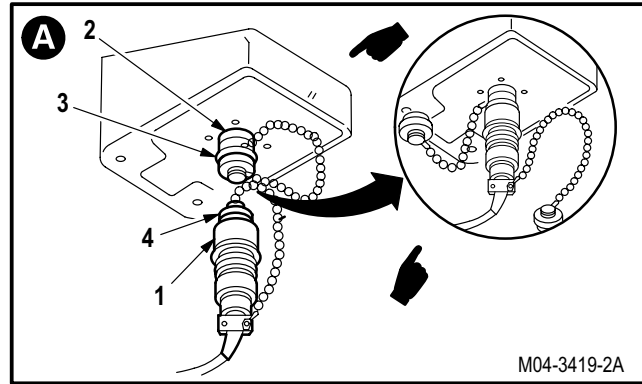

b. **Attach connector (5) to cold start battery (6).**

16.33.4. Operation

**CAUTION**

Only qualified and/or certified personnel are authorized to operate APU. Failure to comply may result in equipment damage.

a. **Enter pilot station (para 1.56). Observe all safety precautions.**

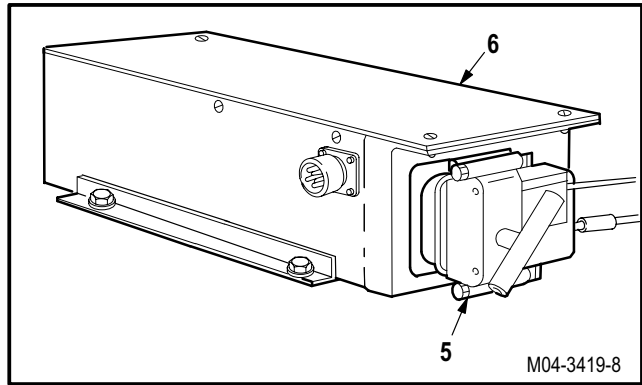

**NOTE**

**95%/NORM** switch is spring loaded to **NORM**. **NORM** switch must be held at **95%** until **APU ON** indicator lights on pilot caution/warning panel.

b. **One person, on APU/FIRE TEST panel (7), set 95%/NORM switch (8) to 95%.**

c. **Operate APU, using battery power (para 1.74).**

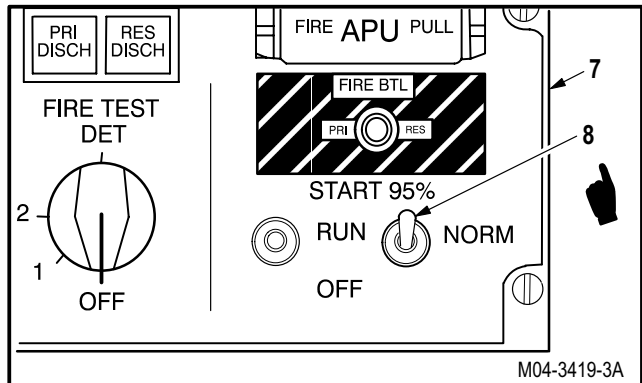

GO TO NEXT PAGE

---

**16.33. APU COLD START - BATTERY - continued**

---

**16.33.5. Removal****a. Detach connector (1) from receptacle J16 (2).**

(1) Remove connector (1) from receptacle (2) and install cap (4).

(2) Install cap (3) on receptacle (2).

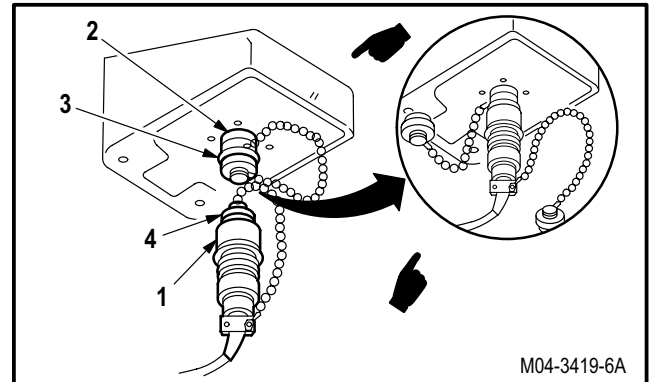
**b. Inspect (QA).****c. Secure access door B60R (para 2.2).**

END OF TASK

## SECTION IV. DESERT OPERATION PROVISIONS MAINTENANCE

---

### 16.34. DESERT OPERATION PROVISIONS DESCRIPTION AND OPERATION

---

#### DESERT OPERATION FILTER KIT (P/N EIA-001)

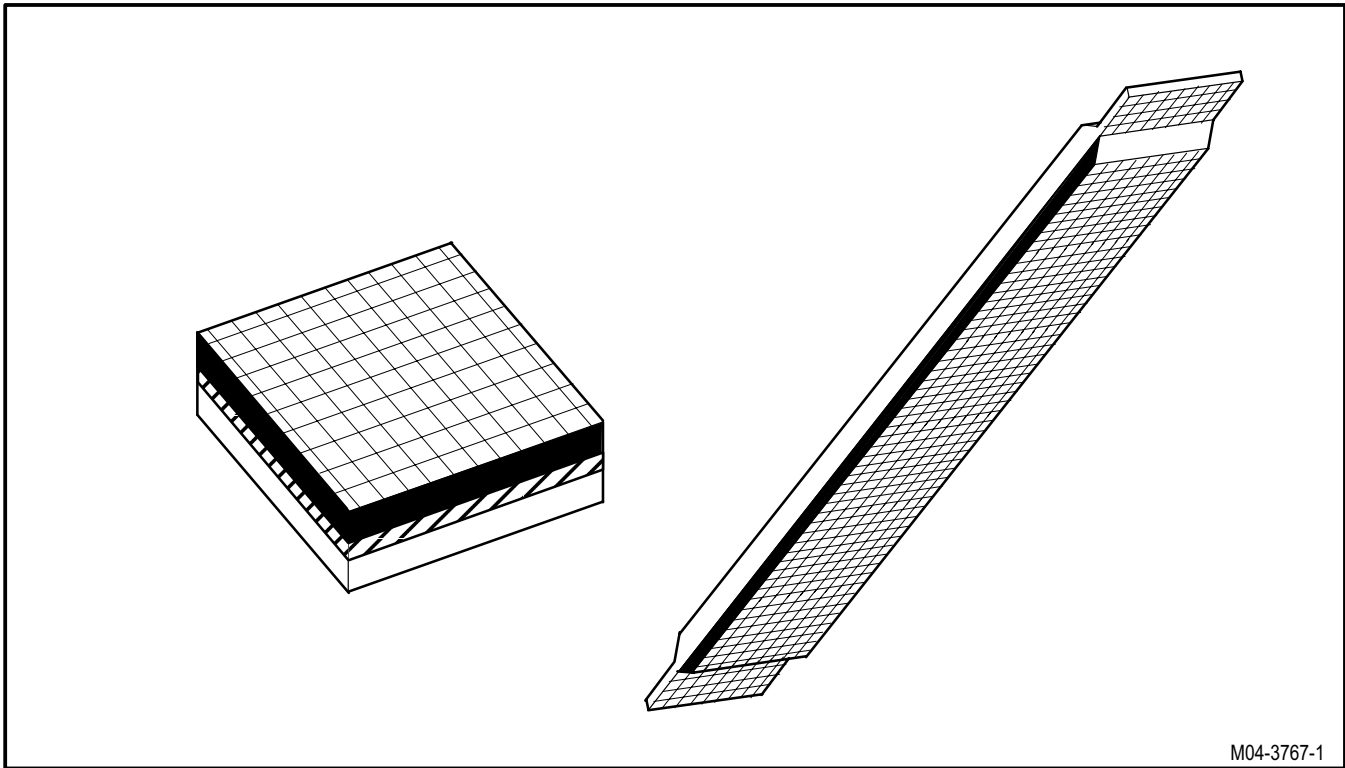

M04-3767-1

(1) AFT AVIONICS BAY DOOR AIR FILTER  
(BGAV2X5X6)

(2) APU AIR FILTER (AH-5X32WV)

#### NOTE

- (1) Refer to paragraph 16.34 for installation instructions.
- (2) Refer to paragraph 16.36 for installation instructions.

END OF TASK

**16.35. AFT AVIONICS BAY AND SURVIVAL BAY FILTER REPLACEMENT**

16.35.1. Description

This task covers: Removal. Cleaning. Inspection. Installation.

16.35.2. Initial Setup

**Tools:**

Aircraft mechanic's tool kit (item 376, App H)

**Personnel Required:**

67R Attack Helicopter Repairer

**Equipment Conditions:**

<u>Ref</u>	<u>Condition</u>
1.57	Helicopter safed
2.2	Access door R295 opened

**CAUTION**

Operating avionics housed in the aft electronics bay with clogged filters could result in inadequate cooling air flowing through the electronics units.

**NOTE**

There are a total of seven filters, three in the R/S Aft Avionics door, two in the L/S Aft Avionics door and two in the R/S Survival Bay door. The following procedure is the same for all three locations.

16.35.3. Removal

- a. **Remove and discard three filters (1) from inlet shields (2).**

16.35.4. Cleaning

- a. **Wipe air inlet shields and screens with a clean rag.**

16.35.5. Inspection

- a. **Check inlet shields and screens for cracks, obstructions, loose or missing parts. None allowed.**

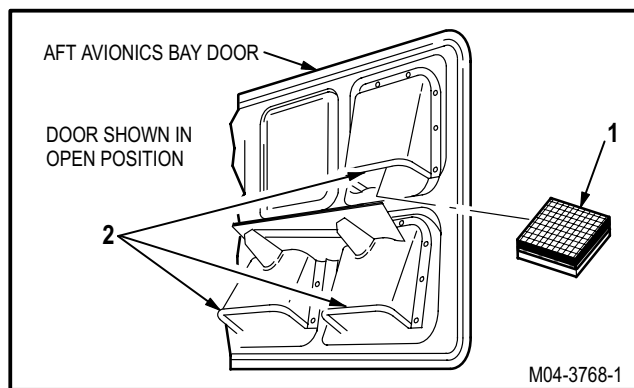

GO TO NEXT PAGE

**16.35. AFT AVIONICS BAY AND SURVIVAL BAY FILTER REPLACEMENT**

16.35.6. Installation

- a. **Fold each filter section (1) into a 2 1/2 X 6 inch filter with white side out.**

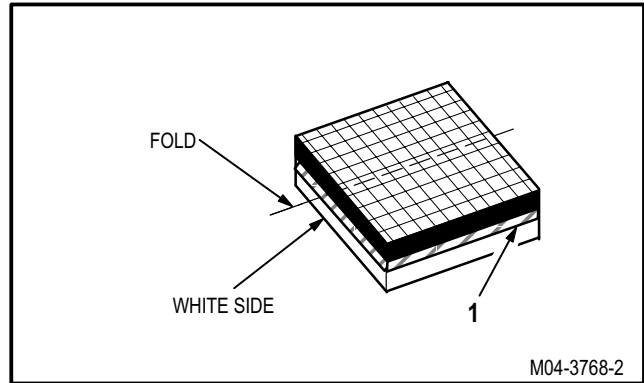

- b. **Install a folded filter (1) in each of the three inlet shields (2) with fold against the outer side of shields.**

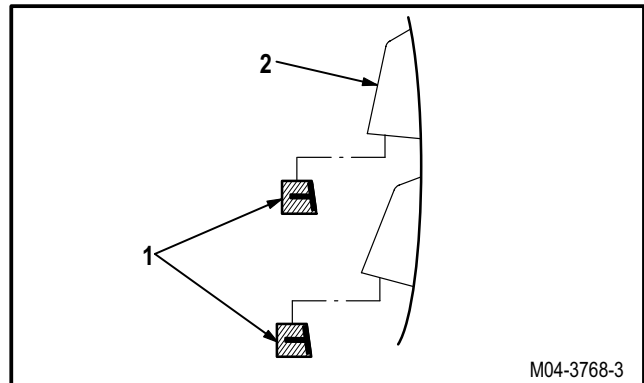

- c. **Secure access door R295 (para 2.2).**

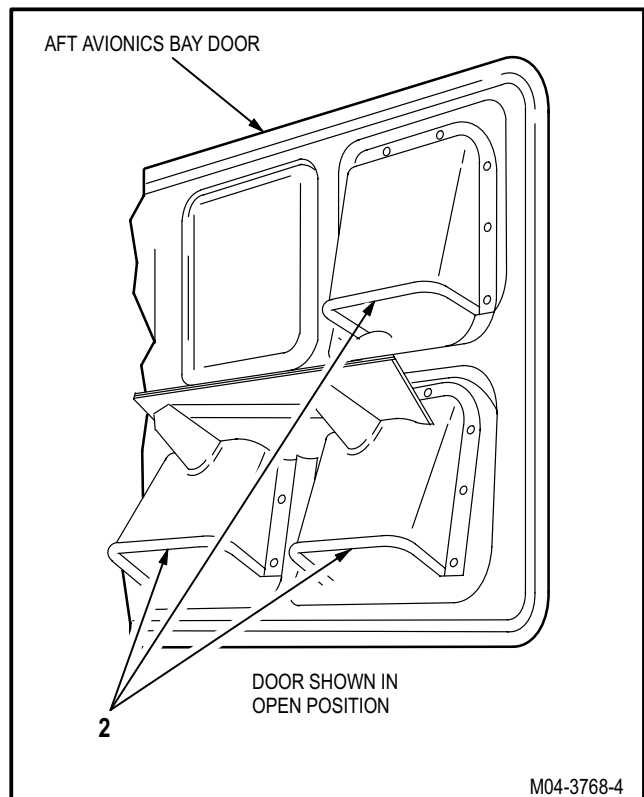

END OF TASK

**16.36. APU AIR FILTER REPLACEMENT**

16.36.1. Description

This task covers: Removal. Cleaning. Inspection. Installation.

16.36.2. Initial Setup

**Tools:**

Aircraft mechanic's tool kit (item 376, App H)

**Personnel Required:**

67R Attack Helicopter Repairer

**Equipment Conditions:**

<u>Ref</u>	<u>Condition</u>
1.57	Helicopter safed
15.41	APU upper center cover removed

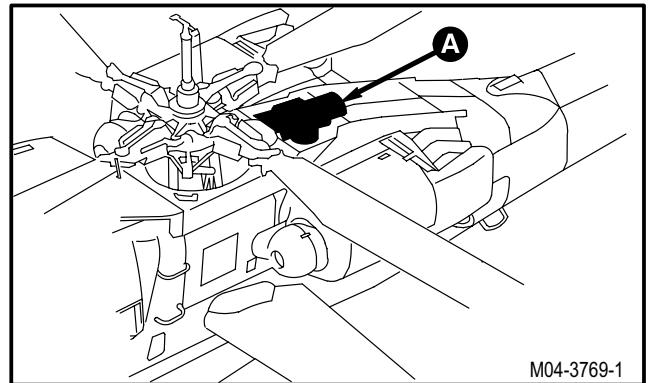

GO TO NEXT PAGE

---

**16.36. APU AIR FILTER REPLACEMENT - continued**

---

16.36.3. Removal

**CAUTION**

Use utmost care when removing filter to prevent particles trapped in the filter from being dumped into the the APU.

a. **Remove APU air filter (1) from APU inlet screen (2).**

(1) Unhook velcro strips (3) from each end of filter (1).

(2) Remove and discard filter (1).

16.36.4. Cleaning

a. **Wipe APU inlet area and inlet screen with a clean rag.**

16.36.5. Inspection

a. **Check APU inlet screen for cracks, obstructions, and loose or missing parts (para 15.1).**

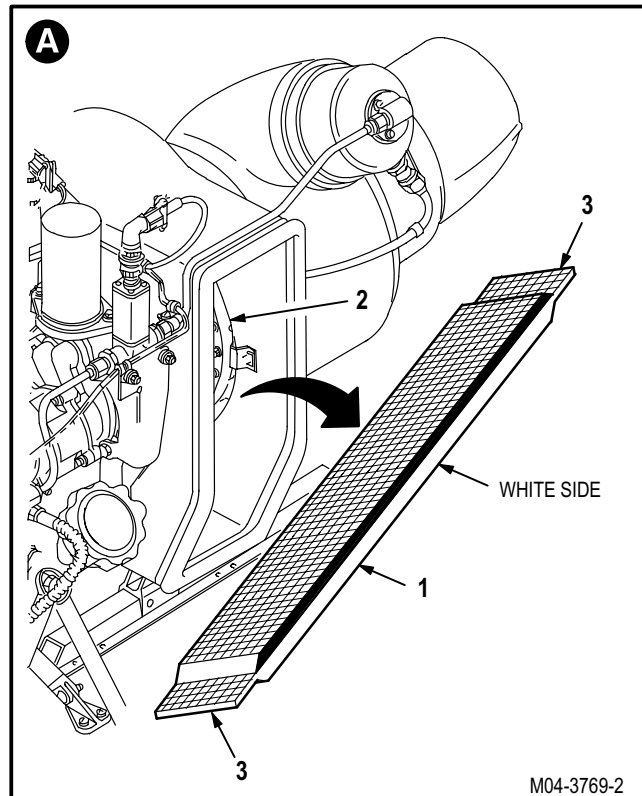

GO TO NEXT PAGE



---

**16.36. APU AIR FILTER REPLACEMENT - continued**

---

16.36.6. Installation

**CAUTION**

During installation, care must be taken to prevent tearing, crushing, or stretching filter material.

a. **Install filter (1) on APU inlet screen (2) with white side out.**

(1) Wrap filter (1) around inlet screen (2) with white side out (push filter away from inlet screen flanges to prevent hang-up on bolts and safety wire).

(2) Secure velcro strips (3) together.

b. **Install APU upper center cover (para 15.42).**

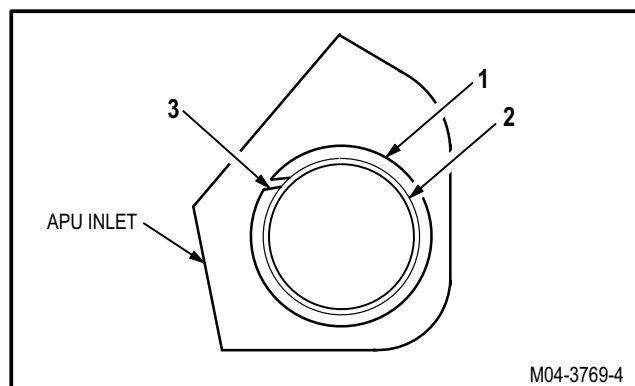
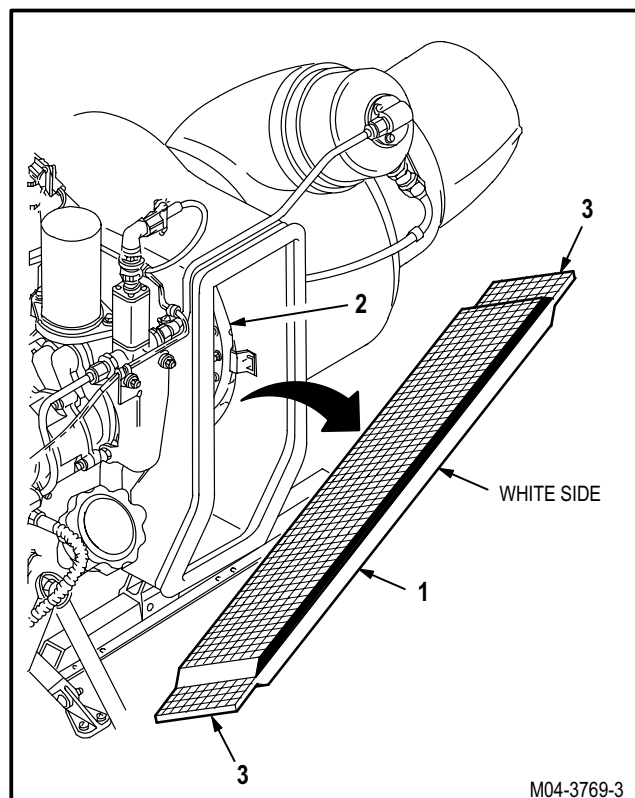

END OF TASK



CHAPTER 17  
EMERGENCY EQUIPMENT

(NOT APPLICABLE)



By Order of the Secretary of the Army:

Official:

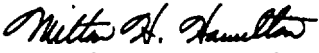
  
MILTON H. HAMILTON  
*Administrative Assistant to the  
Secretary of the Army*  
06971

GORDON R. SULLIVAN  
*General, United States Army  
Chief of Staff*

DISTRIBUTION:

To be distributed in accordance with DA Form 12-31-E, block no. 3448, requirements for TM 1-1520-238-23-8.

\*U.S. GOVERNMENT PRINTING OFFICE: 1994-555-121/80114



## ***These are the instructions for sending an electronic 2028***

The following format must be used if submitting an electronic 2028. The subject line must be exactly the same and all fields must be included; however, only the following fields are mandatory: 1, 3, 4, 5, 6, 7, 8, 9, 10, 13, 15, 16, 17, and 27.

From: "Whomever" [whomever@avma27.army.mil](mailto:whomever@avma27.army.mil)  
To: [2028@redstone.army.mil](mailto:2028@redstone.army.mil)  
Subject DA Form 2028

1. **From:** Joe Smith
2. **Unit:** home
3. **Address:** 4300 Park
4. **City:** Hometown
5. **St:** MO
6. **Zip:** 77777
7. **Date Sent:** 19-OCT-93
8. **Pub no:** 55-2840-229-23
9. **Pub Title:** TM
10. **Publication Date:** 04-JUL-85
11. **Change Number:** 7
12. **Submitter Rank:** MSG
13. **Submitter FName:** Joe
14. **Submitter MName:** T
15. **Submitter LName:** Smith
16. **Submitter Phone:** 123-123-1234
17. **Problem:** 1
18. **Page:** 2
19. **Paragraph:** 3
20. **Line:** 4
21. **NSN:** 5
22. **Reference:** 6
23. **Figure:** 7
24. **Table:** 8
25. **Item:** 9
26. **Total:** 123
27. **Text:**

This is the text for the problem below line 27.





<b>RECOMMENDED CHANGES TO PUBLICATIONS AND BLANK FORMS</b> For use of the for, see AR 25-35; the proponent agency is ODISC4						Use Part II ( <i>reverse</i> ) for Repair Parts and Special Tool Lists (RPSTL) and Supply Catalogs/Supply Manuals (SC/SM).	<b>DATE</b> 8/30/02
<b>TO:</b> ( <i>Forward to proponent of the publication or form</i> ) ( <i>Include ZIP Code</i> ) Commander, U.S. Army Aviation and Missile Command Attn: AMSAM-MMC-MA-NP Redstone Arsenal, AL 35898						<b>FROM:</b> ( <i>Activity and location</i> ) ( <i>Include ZIP Code</i> ) SP4 John Doe F Troop 5 <sup>th</sup> Ca. 1 <sup>st</sup> Taining Bldg. Fort Knox, Kentucky 12345-6789	
<b>PART I - ALL PUBLICATIONS (EXCEPT RPSTL AND SC/SM) AND BLANK FORMS</b>							
PUBLICATION/FORM NUMBER TM 9-1005-43-24						DATE 16 Sep 2002	TITLE Organizational, Direct Support And General Support Maintenance Manual for Machine Gun, .50 Caliber M3P and M3P Machine Gun Electrical Test Set Used on Avenger Air Defense Weapon System
ITEM	PAGE	PARA-GRAPH	LINE	FIGURE NO.	TABLE	RECOMMENDED CHANGES AND REASON	
1	WP0005 PG 3		1			Test or Corrective Action column should identify a different WP number.	
<b>EXAMPLE</b>							
<i>*Reference to line numbers within the paragraph or subparagraph.</i>							
TYPED NAME, GRADE OR TITLE				TELEPHONE EXCHANGE/AUTOVON, PLUS EXTENTION		SIGNATURE	

<b>TO:</b> <i>(Forward direct to addressee listed in publication)</i> Commander, U.S. Army Aviation and Missile Command ATTN: AMSAM-MMC-MA-NP RedstoneArsenal, 35898	<b>FROM:</b> <i>(Activity and location) (Include ZIP Code)</i> MSG, Jane Q. Doe 1234 Any Street Nowhere Town, AL 34565	<b>DATE</b> 8/30/02
---	---	------------------------

**PART II - REPAIR PARTS AND SPECIAL TOOL LISTS AND SUPPLY CATALOGS/SUPPLY MANUALS**

PUBLICATION NUMBER	DATE	TITLE
--------------------	------	-------

PAGE NO.	COLM NO.	LINE NO.	NATIONAL STOCK NUMBER	REFERENCE NO.	FIGURE NO.	ITEM NO.	TOTAL NO. OF MAJOR ITEMS SUPPORTED	RECOMMENDED ACTION

**PART III - REMARKS** *(Any general remarks or recommendations, or suggestions for improvement of publications and blank forms. Additional blank sheets may be used if more space is needed.)*

**EXAMPLE**

TYPED NAME, GRADE OR TITLE	TELEPHONE EXCHANGE/AUTOVON, PLUS EXTENTION	SIGNATURE
----------------------------	--	-----------

<b>RECOMMENDED CHANGES TO PUBLICATIONS AND BLANK FORMS</b> For use of the for, see AR 25-35; the proponent agency is ODISC4						Use Part II ( <i>reverse</i> ) for Repair Parts and Special Tool Lists (RPSTL) and Supply Catalogs/Supply Manuals (SC/SM).	<b>DATE</b>
<b>TO:</b> ( <i>Forward to proponent of the publication or form</i> ) ( <i>Include ZIP Code</i> )						<b>FROM:</b> ( <i>Activity and location</i> ) ( <i>Include ZIP Code</i> )	
<b>PART I - ALL PUBLICATIONS (EXCEPT RPSTL AND SC/SM) AND BLANK FORMS</b>							
PUBLICATION/FORM NUMBER TM 1-1520-238-23-8					DATE 16 May 1994	TITLE Aviation Unit and Intermediate Maintenance Manual for Helicopter, Attack, AH-64A Apache; Volume 8 of 9	
ITEM	PAGE	PARA-GRAPH	LINE	FIGURE NO.	TABLE	RECOMMENDED CHANGES AND REASON	
<i>*Reference to line numbers within the paragraph or subparagraph.</i>							
TYPED NAME, GRADE OR TITLE				TELEPHONE EXCHANGE/AUTOVON, PLUS EXTENTION		SIGNATURE	

<b>TO:</b> <i>(Forward direct to addressee listed in publication)</i>	<b>FROM:</b> <i>(Activity and location) (Include ZIP Code)</i>	<b>DATE</b>
---	--	-------------

**PART II - REPAIR PARTS AND SPECIAL TOOL LISTS AND SUPPLY CATALOGS/SUPPLY MANUALS**

<b>PUBLICATION NUMBER</b> TM 1-1520-238-23-8	<b>DATE</b> 16 May 1994	<b>TITLE</b>
---	----------------------------	--------------

PAGE NO.	COLM NO.	LINE NO.	NATIONAL STOCK NUMBER	REFERENCE NO.	FIGURE NO.	ITEM NO.	TOTAL NO. OF MAJOR ITEMS SUPPORTED	RECOMMENDED ACTION

**PART III - REMARKS** *(Any general remarks or recommendations, or suggestions for improvement of publications and blank forms. Additional blank sheets may be used if more space is needed.)*

--

TYPED NAME, GRADE OR TITLE	TELEPHONE EXCHANGE/AUTOVON, PLUS EXTENTION	SIGNATURE
----------------------------	--	-----------

# The Metric System and Equivalents

## Linear Measure

1 centimeter = 10 millimeters = .39 inch  
 1 decimeter = 10 centimeters = 3.94 inches  
 1 meter = 10 decimeters = 39.37 inches  
 1 dekameter = 10 meters = 32.8 feet  
 1 hectometer = 10 dekameters = 328.08 feet  
 1 kilometer = 10 hectometers = 3,280.8 feet

## Weights

1 centigram = 10 milligrams = .15 grain  
 1 decigram = 10 centigrams = 1.54 grains  
 1 gram = 10 decigrams = .035 ounce  
 1 dekagram = 10 grams = .35 ounce  
 1 hectogram = 10 dekagrams = 3.52 ounces  
 1 kilogram = 10 hectograms = 2.2 pounds  
 1 quintal = 100 kilograms = 220.46 pounds  
 1 metric ton = 10 quintals = 1.1 short tons

## Liquid Measure

1 centiliter = 10 milliliters = .34 fl. ounces  
 1 deciliter = 10 centiliters = 3.38 fl. ounces  
 1 liter = 10 deciliters = 33.81 fl. ounces  
 1 dekaliter = 10 liters = 2.64 gallons  
 1 hectoliter = 10 dekaliters = 26.42 gallons  
 1 kiloliter = 10 hectoliters = 264.18 gallons

## Square Measure

1 sq. centimeter = 100 sq. millimeters = .155 sq. inch  
 1 sq. decimeter = 100 sq. centimeters = 15.5 sq. inches  
 1 sq. meter (centare) = 100 sq. decimeters = 10.76 sq. feet  
 1 sq. dekameter (are) = 100 sq. meters = 1,076.4 sq. feet  
 1 sq. hectometer (hectare) = 100 sq. dekameters = 2.47 acres  
 1 sq. kilometer = 100 sq. hectometers = .386 sq. mile

## Cubic Measure

1 cu. centimeter = 1000 cu. millimeters = .06 cu. inch  
 1 cu. decimeter = 1000 cu. centimeters = 61.02 cu. inches  
 1 cu. meter = 1000 cu. decimeters = 35.31 cu. feet

## Approximate Conversion Factors

To change	To	Multiply by	To change	To	Multiply by
inches	centimeters	2.540	ounce-inches	newton-meters	.007062
feet	meters	.305	centimeters	inches	.394
yards	meters	.914	meters	feet	3.280
miles	kilometers	1.609	meters	yards	1.094
square inches	square centimeters	6.452	kilometers	miles	.621
square feet	square meters	.093	square centimeters	square inches	.155
square yards	square meters	.836	square meters	square feet	10.764
square miles	square kilometers	2.590	square meters	square yards	1.196
acres	square hectometers	.405	square kilometers	square miles	.386
cubic feet	cubic meters	.028	square hectometers	acres	2.471
cubic yards	cubic meters	.765	cubic meters	cubic feet	35.315
fluid ounces	milliliters	29.573	cubic meters	cubic yards	1.308
pints	liters	.473	milliliters	fluid ounces	.034
quarts	liters	.946	liters	pints	2.113
gallons	liters	3.785	liters	quarts	1.057
ounces	grams	28.349	liters	gallons	.264
pounds	kilograms	.454	grams	ounces	.035
short tons	metric tons	.907	kilograms	pounds	2.205
pound-feet	newton-meters	1.356	metric tons	short tons	1.102
pound-inches	newton-meters	.11296			

## Temperature (Exact)

° F Fahrenheit temperature  $\frac{5}{9}$  (after subtracting 32) Celsius temperature ° C

